

160 W STEREO/300W MONO PurePath™ HD Analog-Input Power Stage

FEATURES

- **Active Enabled Integrated Feedback Provides: (PurePath™ HD)**
 - **Signal Bandwidth up to 80kHz for High Frequency Content From High Definition Sources**
 - **Ultra Low 0.03% THD at 1W into 8Ω**
 - **0.03% THD Across all Frequencies for Natural Sound at 1W**
 - **80dB PSRR (BTL, No Input Signal)**
 - **>100dB (A weighted) SNR**
 - **Click and Pop Free Startup**
 - **Minimal External Components Compared to Discrete Solutions**
- **Multiple Configurations Possible on the Same PCB:**
 - **Mono Parallel Bridge Tied Load (PBTL)**
 - **2.1 Single Ended (SE) Stereo Pair and Bridge Tied Load (BTL) Subwoofer**
 - **Quad Single Ended (SE) Outputs**
- **Total Output Power at 10%THD+N**
 - **300W in Mono PBTL Configuration**
 - **160W per Channel in Stereo BTL**
 - **80W per Channel in Quad Single Ended**
- **High Efficiency Power Stage (> 90%) With 120 mΩ Output MOSFETs**
- **Two Thermally Enhanced Package Options:**
 - **PHD (64-pin QFP)**
 - **DKD (44-pin PSOP3)**
- **Self-Protection Design (Including Undervoltage, Overtemperature, Clipping, and Short Circuit Protection) With Error Reporting**
- **EMI Compliant When Used With Recommended System Design**

APPLICATIONS

- **Mini Combo System**
- **AV Receivers**
- **DVD Receivers**
- **Active Speakers**

DESCRIPTION

The TAS5615 is a high-performance analog input Class D amplifier with integrated closed loop feedback technology (known as PurePath™ HD). It has the ability to drive up to 160 W⁽¹⁾ Stereo into 8Ω speakers from a single 50V supply.

PurePath™ HD technology enables traditional AB-Amplifier performance (<0.03% THD) levels while providing the power efficiency of traditional class D amplifiers.

Ultra Low 0.03% THD+N is flat across all frequencies, ensuring that the amplifier doesn't add uneven distortion characteristics, and helps maintain a natural sound.

The efficiency of this Class-D amplifier is greater than 90%. Undervoltage Protection, Overtemperature, clipping, Short Circuit and Overcurrent Protection are all integrated, safeguarding the device and speakers against fault conditions that could damage the system.

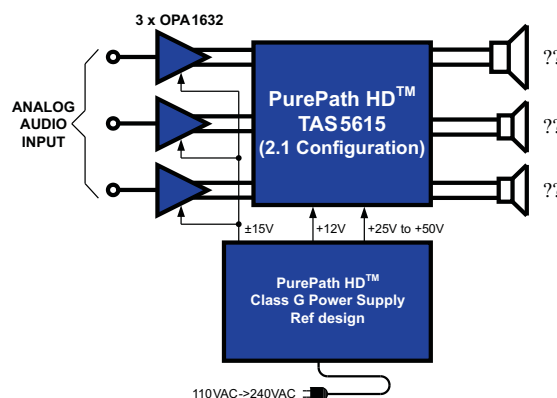

- (1) Achievable output power levels are dependent on the thermal configuration of the target application. A high performance thermal interface material between the package exposed heatslug and the heat sink should be used to achieve high output power levels



Please be aware that an important notice concerning availability, standard warranty, and use in critical applications of Texas Instruments semiconductor products and disclaimers thereto appears at the end of this data sheet.

All trademarks are the property of their respective owners.



These devices have limited built-in ESD protection. The leads should be shorted together or the device placed in conductive foam during storage or handling to prevent electrostatic damage to the MOS gates.

DEVICE INFORMATION

Terminal Assignment

The TAS5615 is available in two thermally enhanced packages:

- 64-Pin QFP (PHD) Power Package
- 44-Pin PSOP3 package (DKD)

The package type contains a heat slug that is located on the top side of the device for convenient thermal coupling to the heat sink.

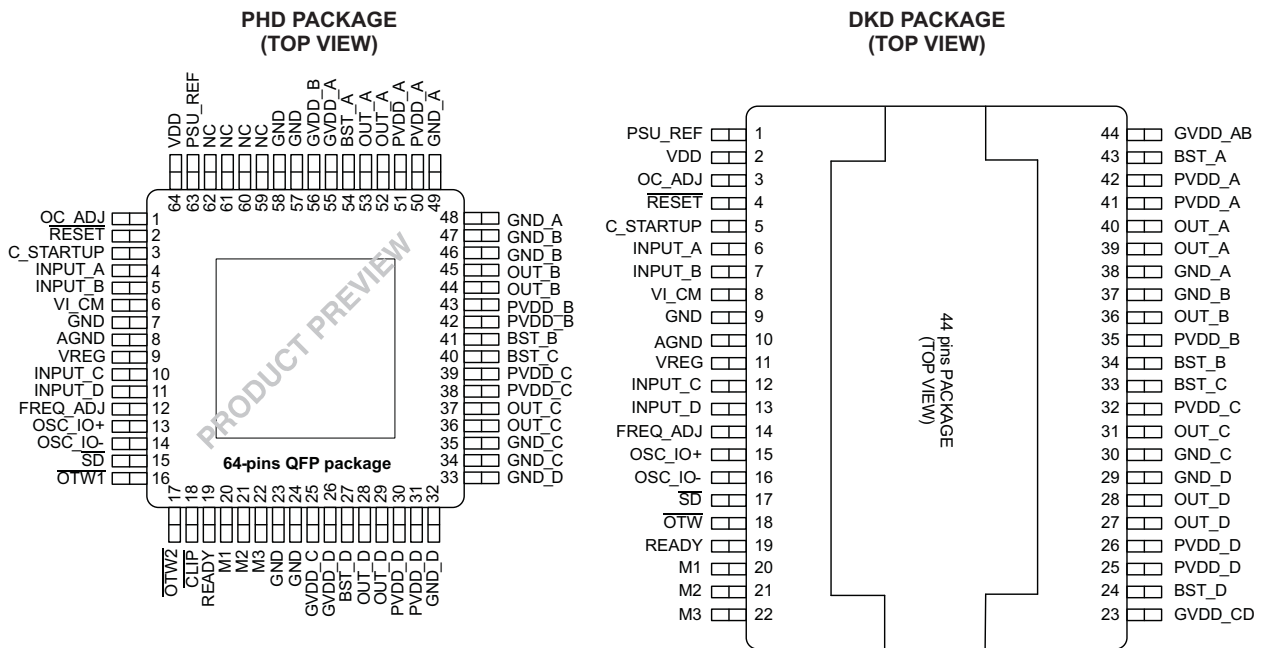

PIN ONE LOCATION PHD PACKAGE

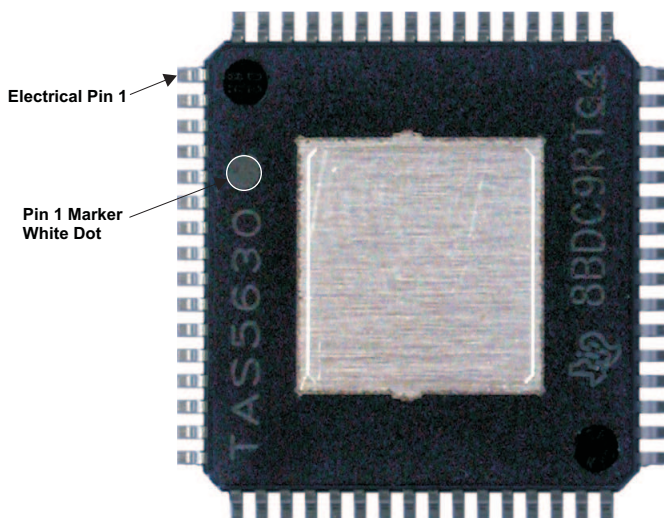

MODE SELECTION PINS

MODE PINS			ANALOG INPUT	OUTPUT CONFIGURATION	DESCRIPTION		
M3	M2	M1					
0	0	0	Differential	2 × BTL	AD mode		
0	0	1	—	—	Reserved		
0	1	0	Differential	2 × BTL	BD mode		
0	1	1	Differential Single Ended	1 × BTL +2 × SE	AD mode, BTL Differential		
1	0	0	Single Ended	4 × SE	AD mode		
1	0	1	Differential	1 × PBTL	INPUT_C⁽¹⁾	INPUT_D⁽¹⁾	
					0	0	AD mode
					1	0	BD mode
1	1	0	Reserved				
1	1	1					

(1) INPUT_C and D are used to select between a subset of AD and BD mode operations in PBTL mode (1=VREG and 0=AGND).

PACKAGE HEAT DISSIPATION RATINGS⁽¹⁾

PARAMETER	TAS5615PHD	TAS5615DKD
$R_{\theta JC}$ (°C/W) – 2 BTL or 4 SE channels	3.63	2.52
$R_{\theta JC}$ (°C/W) – 1 BTL or 2 SE channel(s)	5.95	3.22
$R_{\theta JC}$ (°C/W) – 1 SE channel	9.9	6.9
Pad Area ⁽²⁾	49 mm ²	80 mm ²

(1) J_C is junction-to-case, CH is case-to-heat sink

(2) $R_{\theta H}$ is an important consideration. Assume a 2-mil thickness of typical thermal grease between the pad area and the heat sink and both channels active. The $R_{\theta CH}$ with this condition is 1.22°C/W for the PHD package and 1.02°C/W for the DKD package.

ORDERING INFORMATION⁽¹⁾

T_A	PACKAGE	DESCRIPTION
0°C–70°C	TAS5615PHD ⁽²⁾	64 pin HTQFP
0°C–70°C	TAS5615DKD	44 pin PSOP3

(1) For the most current package and ordering information, see the Package Option Addendum at the end of this document, or see the TI website at www.ti.com.

(2) Product Preview

TAS5615

SLAS595–JUNE 2009

www.ti.com

ABSOLUTE MAXIMUM RATINGS

 over operating free-air temperature range unless otherwise noted ⁽¹⁾

TAS5615		UNIT	
VDD to AGND		–0.3 to 13.2	V
GVDD to AGND		–0.3 to 13.2	V
PVDD_X to GND_X ⁽²⁾		–0.3 to 69.0	V
OUT_X to GND_X ⁽²⁾		–0.3 to 69.0	V
BST_X to GND_X ⁽²⁾		–0.3 to 82.2	V
BST_X to GVDD_X ⁽²⁾		–0.3 to 69.0	V
VREG to AGND		–0.3 to 4.2	V
GND_X to GND		–0.3 to 0.3	V
GND_X to AGND		–0.3 to 0.3	V
OC_ADJ, M1, M2, M3, OSC_IO+, OSC_IO–, FREQ_ADJ, VI_CM, C_STARTUP, PSU_REF to AGND		–0.3 to 4.2	V
INPUT_X		–0.3 to 5	V
RESET, SD, OTW1, OTW2, CLIP, READY to AGND		–0.3 to 7.0	V
Continuous sink current (SD, OTW1, OTW2, CLIP, READY)		9	mA
Operating junction temperature range, T _J		0 to 150	°C
Storage temperature, T _{stg}		–40 to 150	°C
Electrostatic discharge	Human-Body Model ⁽³⁾ (all pins)	±2	kV
	Charged-Device Model ⁽³⁾ (all pins)	±500	V

- (1) Stresses beyond those listed under *Absolute Maximum Ratings* may cause permanent damage to the device. These are stress ratings only, and functional operation of the device at these or any other conditions beyond those indicated under *Recommended Operating Conditions* is not implied. Exposure to absolute-maximum-rated conditions for extended periods may affect device reliability.
- (2) These voltages represents the DC voltage + peak AC waveform measured at the terminal of the device in all conditions.
- (3) Failure to follow good anti-static ESD handling during manufacture and rework will contribute to device malfunction. Make sure the operators handling the device are adequately grounded through the use of ground straps or alternative ESD protection.

RECOMMENDED OPERATING CONDITIONS

over operating free-air temperature range (unless otherwise noted)

			MIN	NOM	MAX	UNIT
PVDD_x	Half-bridge supply	DC supply voltage	25	50	52.5	V
GVDD_x	Supply for logic regulators and gate-drive circuitry	DC supply voltage	10.8	12	13.2	V
VDD	Digital regulator supply voltage	DC supply voltage	10.8	12	13.2	V
R _L (BTL)	Load impedance	Output filter according to schematics in the application information section.	7	8.0		Ω
R _L (SE)			3.5	4.0		
R _L (PBTL)			3.5	4.0		
L _{OUTPUT} (BTL)	Output filter inductance	Minimum output inductance at I _{OC}	14	15		μH
L _{OUTPUT} (SE)			14	15		
L _{OUTPUT} (PBTL)			14	15		
F _{PWM}	PWM frame rate selectable for AM interference avoidance; 1% Resistor tolerance	Nominal	350	400	450	kHz
		AM1	310	340	350	
		AM2	260	300	320	
R _{FREQ_ADJ}	PWM frame rate programming resistor	Nominal; Master mode	9.5	10	10.5	kΩ
		AM1; Master mode	19.8	20	20.2	
		AM2; Master mode	29.7	30	30.3	
V _{FREQ_ADJ}	Voltage on FREQ_ADJ pin for slave mode operation	Slave mode	3.3			
T _J	Junction temperature		0		150	°C

PIN FUNCTIONS

PIN			FUNCTION ⁽¹⁾	DESCRIPTION
NAME	PHD NO.	DKD NO.		
AGND	8	10	P	Analog ground
BST_A	54	43	P	HS bootstrap supply (BST), external 0.033 μ F capacitor to OUT_A required.
BST_B	41	34	P	HS bootstrap supply (BST), external 0.033 μ F capacitor to OUT_B required.
BST_C	40	33	P	HS bootstrap supply (BST), external 0.033 μ F capacitor to OUT_C required.
BST_D	27	24	P	HS bootstrap supply (BST), external 0.033 μ F capacitor to OUT_D required.
/CLIP	18	–	O	Clipping warning; open drain; active low
C_STARTUP	3	5	O	Startup ramp requires a charging capacitor of 4.7 nF to AGND
FREQ_ADJ	12	14	I	PWM frame rate programming pin requires resistor to AGND
GND	7, 23, 24, 57, 58	9	P	Ground
GND_A	48, 49	38	P	Power ground for half-bridge A
GND_B	46, 47	37	P	Power ground for half-bridge B
GND_C	34, 35	30	P	Power ground for half-bridge C
GND_D	32, 33	29	P	Power ground for half-bridge D
GVDD_A	55	–	P	Gate drive voltage supply requires 0.1 μ F capacitor to GND_A
GVDD_B	56	–	P	Gate drive voltage supply requires 0.1 μ F capacitor to GND_B
GVDD_C	25	–	P	Gate drive voltage supply requires 0.1 μ F capacitor to GND_C
GVDD_D	26	–	P	Gate drive voltage supply requires 0.1 μ F capacitor to GND_D
GVDD_AB	–	44	P	Gate drive voltage supply requires 0.22 μ F capacitor to GND_A/GND_B
GVDD_CD	–	23	P	Gate drive voltage supply requires 0.22 μ F capacitor to GND_C/GND_D
INPUT_A	4	6	I	Input signal for half bridge A
INPUT_B	5	7	I	Input signal for half bridge B
INPUT_C	10	12	I	Input signal for half bridge C
INPUT_D	11	13	I	Input signal for half bridge D
M1	20	20	I	Mode selection
M2	21	21	I	Mode selection
M3	22	22	I	Mode selection
NC	59-62	–	–	No connect, pins may be grounded.
OC_ADJ	1	3	O	Analog over current programming pin requires resistor to ground: 64 pin QFP package (PHD) = 22 k Ω 44 pin PSOP3 Package (DKD) = 24 k Ω
OSC_IO+	13	15	I/O	Oscillator master/slave output/input.
OSC_IO–	14	16	I/O	Oscillator master/slave output/input.
/OTW	–	18	O	Overtemperature warning signal, open drain, active low.
/OTW1	16	–	O	Overtemperature warning signal, open drain, active low.
/OTW2	17	–	O	Overtemperature warning signal, open drain, active low.
OUT_A	52, 53	39, 40	O	Output, half bridge A
OUT_B	44, 45	36	O	Output, half bridge B
OUT_C	36, 37	31	O	Output, half bridge C
OUT_D	28, 29	27, 28	O	Output, half bridge D
PSU_REF	63	1	P	PSU Reference requires close decoupling of 330 pF to AGND
PVDD_A	50, 51	41, 42	P	Power supply input for half bridges A requires close decoupling of 2.2- μ F capacitor to GND_A.
PVDD_B	42, 43	35	P	Power supply input for half bridges B requires close decoupling of 2.2- μ F capacitor to GND_B.
PVDD_C	38, 39	32	P	Power supply input for half bridges C requires close decoupling of 2.2- μ F capacitor to GND_C.

(1) I = Input, O = Output, P = Power

PIN FUNCTIONS (continued)

PIN			FUNCTION ⁽¹⁾	DESCRIPTION
NAME	PHD NO.	DKD NO.		
PVDD_D	30, 31	25, 26	P	Power supply input for half bridges D requires close decoupling of 2.2- μ F capacitor to GND_D.
READY	19	19	O	Normal operation; open drain; active high
$\overline{\text{RESET}}$	2	4	I	Device reset Input; active low, requires 47k Ω pull up resistor to VREG
$\overline{\text{SD}}$	15	17	O	Shutdown signal, open drain, active low
VDD	64	2	P	Power supply for internal voltage regulator requires a 10- μ F capacitor with a 0.1- μ F capacitor to GND for decoupling.
VI_CM	6	8	O	Analog comparator reference node requires close decoupling of 1 nF to GND
VREG	9	11	P	Internal regulator supply filter pin requires 0.1- μ F capacitor to GND

TYPICAL SYSTEM BLOCK DIAGRAM

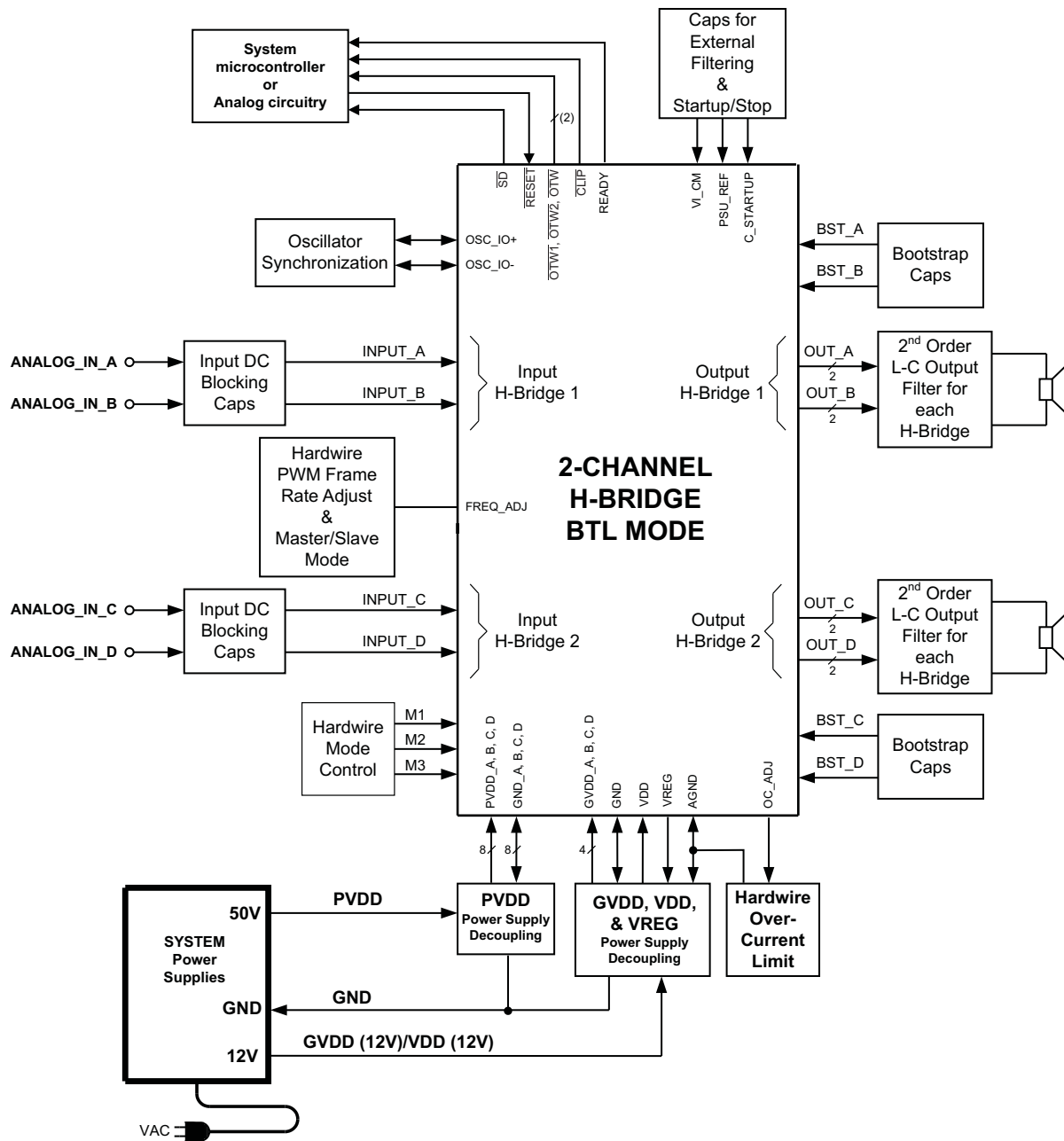

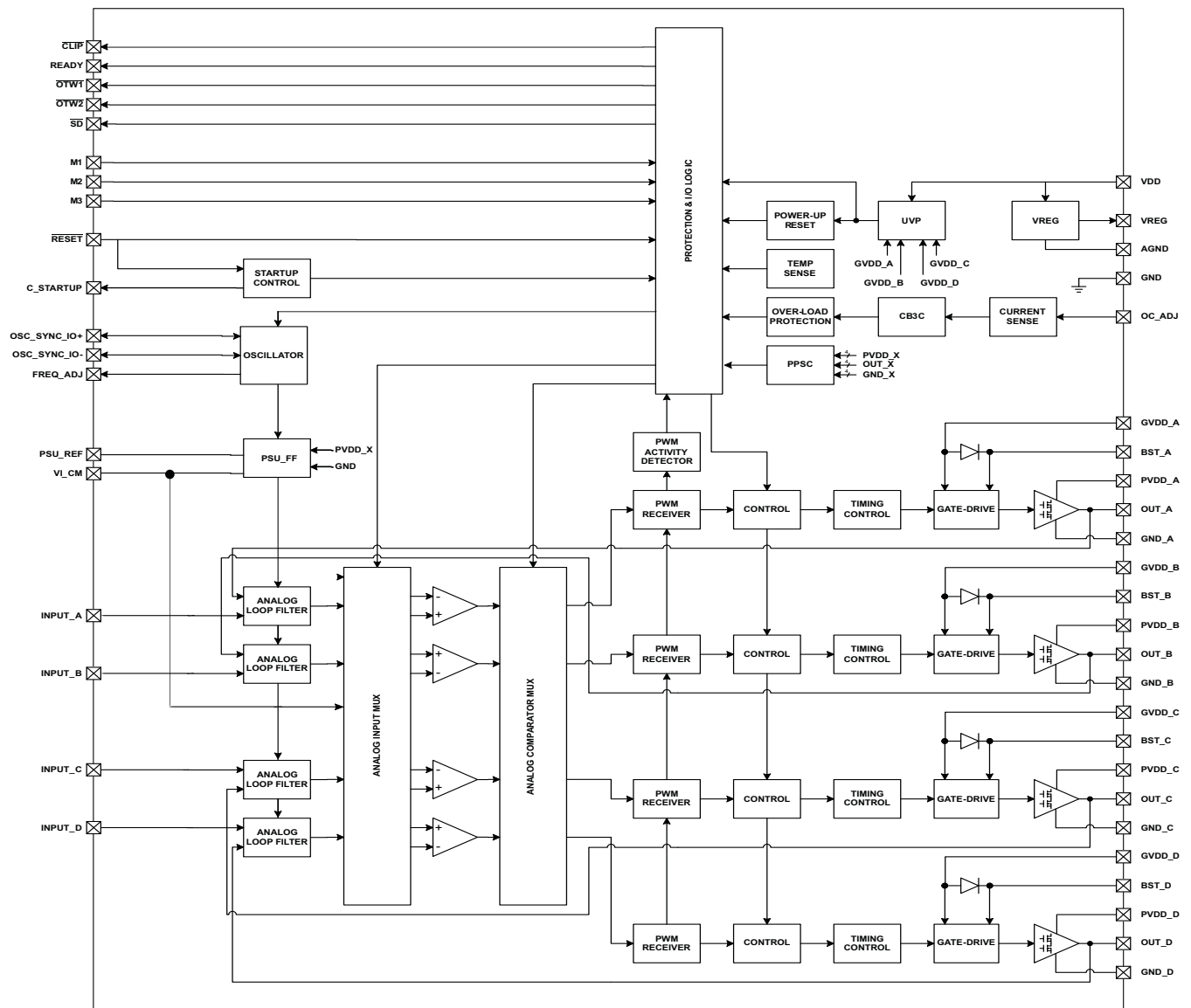
FUNCTIONAL BLOCK DIAGRAM

AUDIO CHARACTERISTICS (BTL)

PCB and system configuraton are in accordance with recommended guidelines. Audio frequency = 1kHz, PVDD_X = 50 V, GVDD_X = 12 V, R_L = 8Ω, f_S = 400 kHz, R_{OC} = 22 kΩ, T_C = 75°C, Output Filter: L_{DEM} = 15μH, C_{DEM} = 680nF, mode = 010, unless otherwise noted.

PARAMETER		TEST CONDITIONS	MIN	TYP	MAX	UNIT
P _O	Power output per channel	R _L = 8 Ω, 10% THD+N, clipped output signal		160		W
		R _L = 8 Ω, 1% THD+N, unclipped output signal		125		
THD+N	Total harmonic distortion + noise	1 W		0.05		%
V _n	Output integrated noise	A-weighted, AES17 filter, Input Capacitor Grounded		260		μV
V _{OS}	Output offset voltage	Inputs AC coupled to AGND		40	150	mV
SNR	Signal-to-noise ratio ⁽¹⁾			100		dB
DNR	Dynamic range			100		dB
P _{idle}	Power dissipation due to Idle losses (I _{PVDD_X})	P _O = 0, 4 channels switching ⁽²⁾		2.3		W

(1) SNR is calculated relative to 1% THD+N output level.

(2) Actual system idle losses also are affected by core losses of output inductors.

AUDIO SPECIFICATION (Single-Ended Output)

PCB and system configuraton are in accordance with recommended guidelines. Audio frequency = 1kHz, PVDD_X = 50 V, GVDD_X = 12 V, R_L = 4Ω, f_S = 400 kHz, R_{OC} = 22 kΩ, T_C = 75°C, Output Filter: L_{DEM} = 15μH, C_{DEM} = 330nF, MODE = 100, unless otherwise noted.

PARAMETER		TEST CONDITIONS	MIN	TYP	MAX	UNIT
P _O	Power output per channel	R _L = 4 Ω, 10% THD+N, clipped output signal		75		W
		R _L = 4 Ω, 1% THD+N, unclipped output signal		60		
THD+N	Total harmonic distortion + noise	1 W		0.05		%
V _n	Output integrated noise	A-weighted		350		μV
SNR	Signale to noise ratio ⁽¹⁾	A-weighted		93		dB
DNR	Dynamic range	A-weighted		93		dB
P _{idle}	Power dissipation due to idle losses (I _{PVDD_X})	P _O = 0, 4 channels switching ⁽²⁾		1.15		W

(1) SNR is calculated relative to 1% THD+N output level.

(2) Actual system idle losses are affected by core losses of output inductors.

AUDIO SPECIFICATION (PBTL)

PCB and system configuraton are in accordance with recommended guidelines. Audio frequency = 1kHz, PVDD_X = 50 V, GVDD_X = 12 V, R_L = 4Ω, f_S = 400 kHz, R_{OC} = 22 kΩ, T_C = 75°C, Output Filter: L_{DEM} = 15μH, C_{DEM} = 680nF, MODE = 101-BD, unless otherwise noted.

PARAMETER		TEST CONDITIONS	MIN	TYP	MAX	UNIT
P _O	Power output per channel	R _L = 4 Ω, 10% THD+N, clipped output signal		300		W
		R _L = 6 Ω, 10% THD+N, clipped output signal		210		
		R _L = 8 Ω, 10% THD+N, clipped output signal		160		
		R _L = 4 Ω, 1% THD+N, unclipped output signal		240		
		R _L = 6 Ω, 1% THD+N, unclipped output signal		160		
		R _L = 8 Ω, 1% THD+N, unclipped output signal		125		
THD+N	Total harmonic distortion + noise	1 W		0.05		%
V _n	Output integrated noise	A-weighted		260		μV
SNR	Signale to noise ratio ⁽¹⁾	A-weighted		100		dB
DNR	Dynamic range	A-weighted		100		dB
P _{idle}	Power dissipation due to idle losses (IPVDD_X)	P _O = 0, 4 channels switching ⁽²⁾		2.3		W

(1) SNR is calculated relative to 1% THD+N output level.

(2) Actual system idle losses are affected by core losses of output inductors.

ELECTRICAL CHARACTERISTICS

PVDD_X = 50.0 V, GVDD_X = 12 V, VDD = 12 V, T_C (Case temperature) = 75°C, f_S = 400 kHz, unless otherwise specified.

PARAMETER		TEST CONDITIONS	MIN	TYP	MAX	UNIT	
INTERNAL VOLTAGE REGULATOR AND CURRENT CONSUMPTION							
VREG	Voltage regulator, only used as reference node	VDD = 12 V	3	3.3	3.6	V	
VI_CM	Analog comparator reference node		1.5	1.75	1.9	V	
IVDD	VDD supply current	Operating, 50% duty cycle		22.5		mA	
		Idle, reset mode		22.5			
I _{GVDD_X}	Gate-supply current per half-bridge	50% duty cycle		8		mA	
		Reset mode		1.5			
I _{PVDD_X}	Half-bridge idle current	50% duty cycle without output filter or load		7		mA	
		Reset mode, No switching		610			μA
ANALOG INPUTS							
R _{IN}	Input resistance	READY = HIGH		33		kΩ	
V _{IN}	Maximum input voltage swing			5		V	
I _{IN}	Maximum input current			342		mA	
G	Voltage Gain (V _{OUT} /V _{IN})			23		dB	
OSCILLATOR							
f _{OSC_IO+}	Nominal, Master Mode	F _{PWM} × 10		3.5	4	4.5	MHz
	AM1, Master Mode			3.1	3.4	3.5	
	AM2, Master Mode			2.6	3	3.2	
V _{IH}	High level input voltage		1.86			V	
V _{IL}	Low level input voltage				1.45	V	
OUTPUT-STAGE MOSFETS							
R _{Ds(on)}	Drain-to-source resistance, low side (LS)	T _J = 25°C, Includes metallization resistance, GVDD = 12 V		120	200	mΩ	
	Drain-to-source resistance, high side (HS)			120	200	mΩ	

ELECTRICAL CHARACTERISTICS (continued)

 PVDD_X = 50.0 V, GVDD_X = 12 V, VDD = 12 V, T_C (Case temperature) = 75°C, f_S = 400 kHz, unless otherwise specified.

PARAMETER		TEST CONDITIONS	MIN	TYP	MAX	UNIT
I/O PROTECTION						
V _{uvp,G}	Undervoltage protection limit, GVDD_x and VDD			9.5		V
V _{uvp,hyst} ⁽¹⁾				0.6		V
OTW1 ⁽¹⁾	Overtemperature warning 1		95	100	105	°C
OTW2 ⁽¹⁾	Overtemperature warning 2		115	125	135	°C
OTW _{HYST} ⁽¹⁾	Temperature drop needed below OTW temperature for OTW to be inactive after OTW event.			25		°C
OTE ⁽¹⁾	Overtemperature error		145	155	165	°C
OTE-OTW _{differential} ⁽¹⁾	OTE-OTW differential			30		°C
OTE _{HYST} ⁽¹⁾	A reset needs to occur for \overline{SD} to be released following an OTE event			25		°C
OLPC	Overload protection counter	f _{PWM} = 400 kHz		1.3		ms
I _{OC}	Overcurrent limit protection	Resistor – programmable, nominal continuous current in 1Ω load, 64 Pin QFP package (PHD), R _{OCP} = 22 kΩ		10		A
		Resistor – programmable, nominal continuous current in 1Ω load, 44 Pin PSOP3 package (DKD), R _{OCP} = 24 kΩ		10		A
I _{OC_LATCHED}	Overcurrent limit protection	Resistor – programmable, continuous current in 1Ω load, R _{OCP} = 47 kΩ		10		A
I _{OCT}	Overcurrent response time	Time from switching transition to flip-state induced by overcurrent.		150		ns
I _{PD}	Output pulldown current of each half	Connected when \overline{RESET} is active to provide bootstrap charge. Not used in SE mode.		3		mA
STATIC DIGITAL SPECIFICATIONS						
V _{IH}	High level input voltage	INPUT_X, M1, M2, M3, RESET	1.9			V
V _{IL}	Low level input voltage				1.45	
Leakage	Input leakage current				100	μA
OTW/SHUTDOWN (SD)						
R _{INT_PU}	Internal pullup resistance, $\overline{OTW1}$ to VREG, $\overline{OTW2}$ to VREG, \overline{SD} to VREG		20	26	32	kΩ
V _{OH}	High level output voltage	Internal pullup resistor	3	3.3	3.6	V
		External pullup of 4.7 kΩ to 5 V	4.5		5	
V _{OL}	Low level output voltage	I _O = 4 mA		200	500	mV
FANOUT	Device fanout $\overline{OTW1}$, $\overline{OTW2}$, \overline{SD} , \overline{CLIP} , \overline{READY}	No external pullup		30		devices

(1) Specified by design.

TYPICAL CHARACTERISTICS, BTL CONFIGURATION

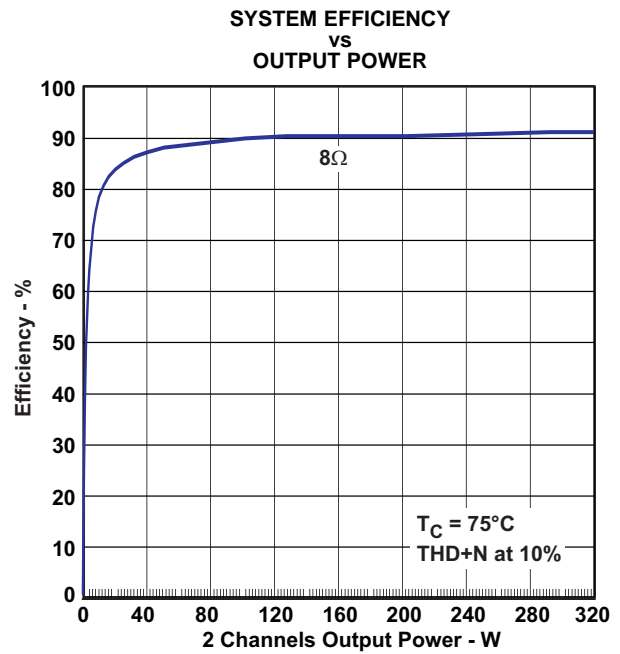
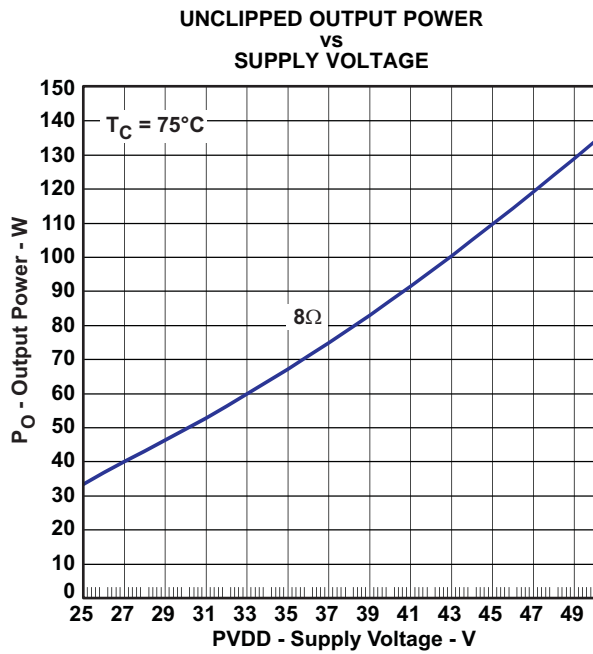
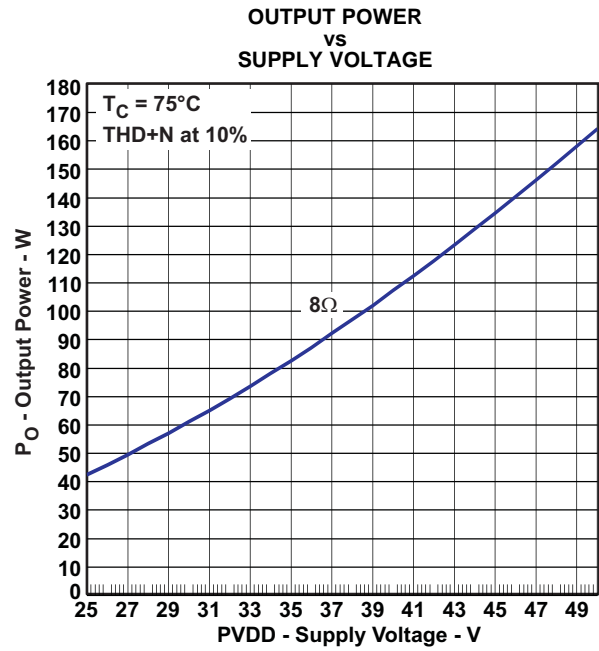
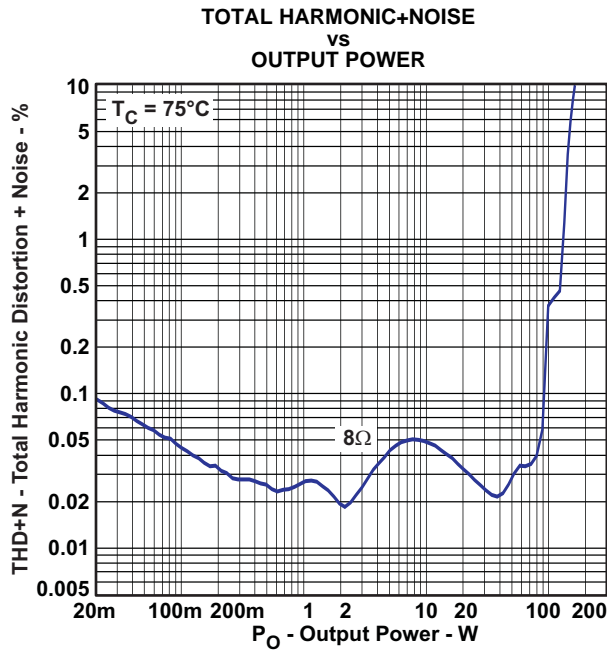

TYPICAL CHARACTERISTICS, BTL CONFIGURATION (continued)

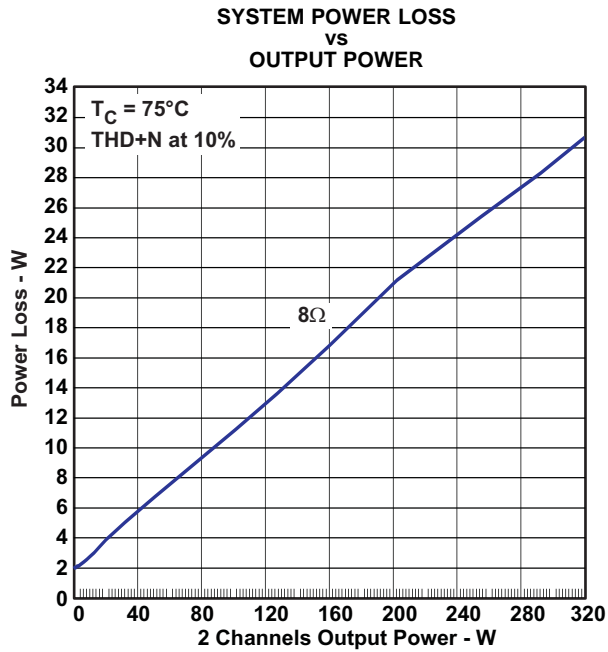

Figure 5.

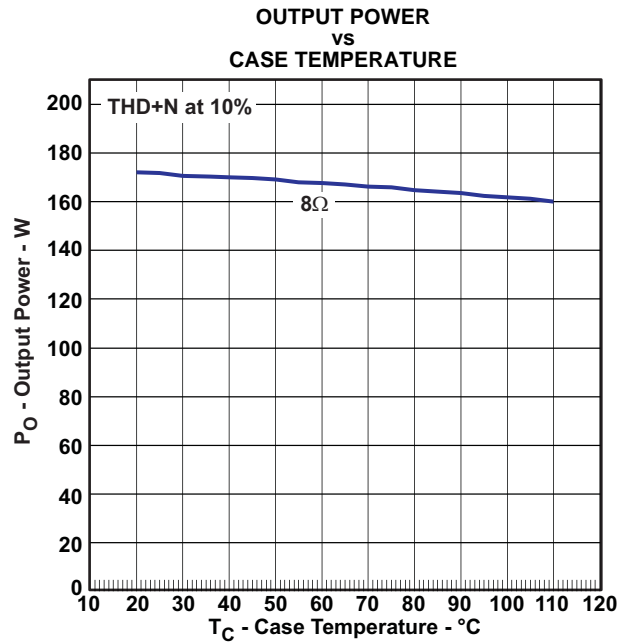

Figure 6.

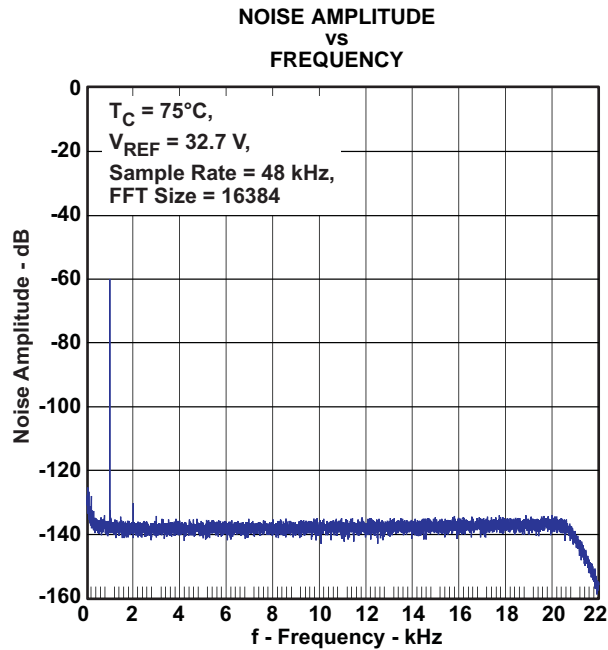

Figure 7.

TYPICAL CHARACTERISTICS, SE CONFIGURATION

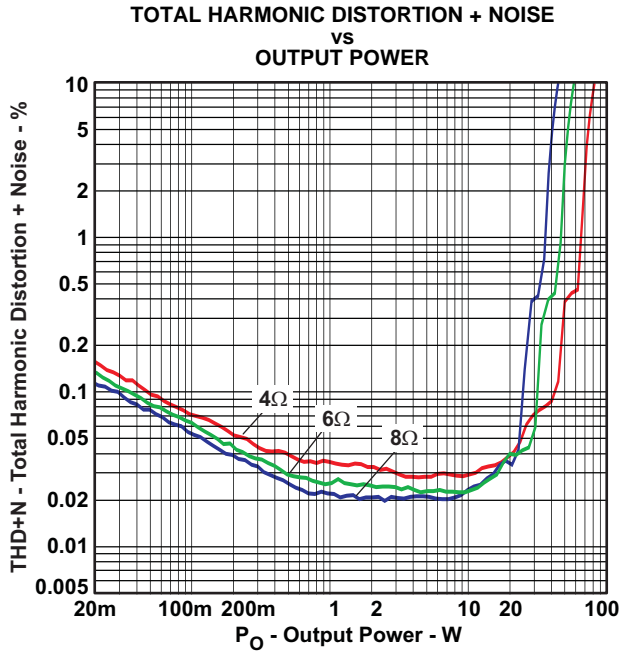

Figure 8.

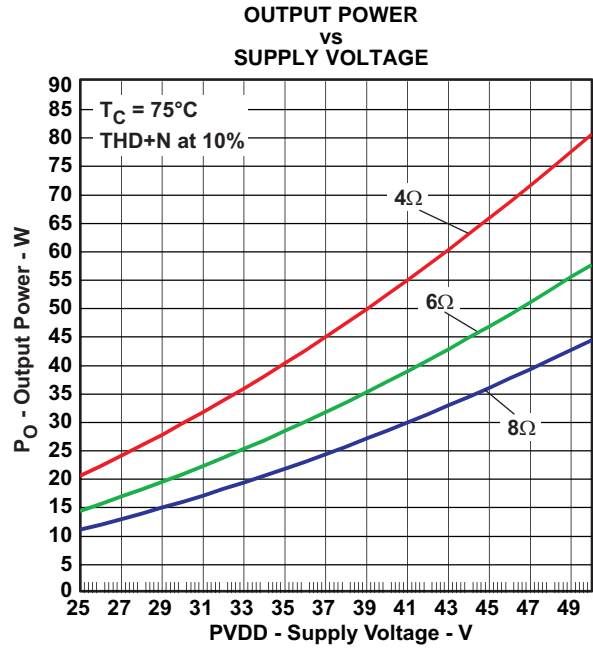

Figure 9.

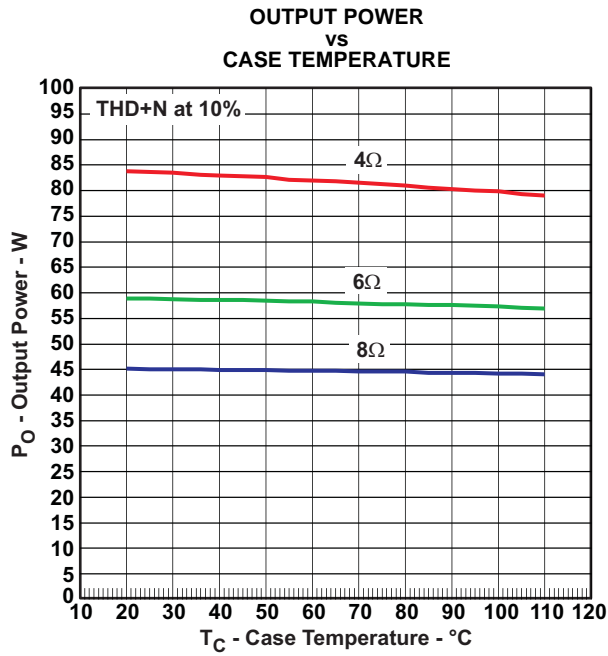

Figure 10.

TYPICAL CHARACTERISTICS, PBTL CONFIGURATION

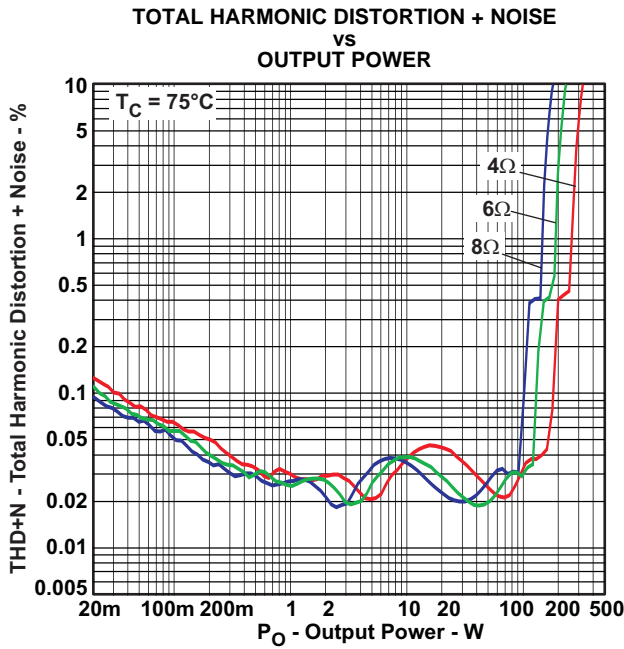

Figure 11.

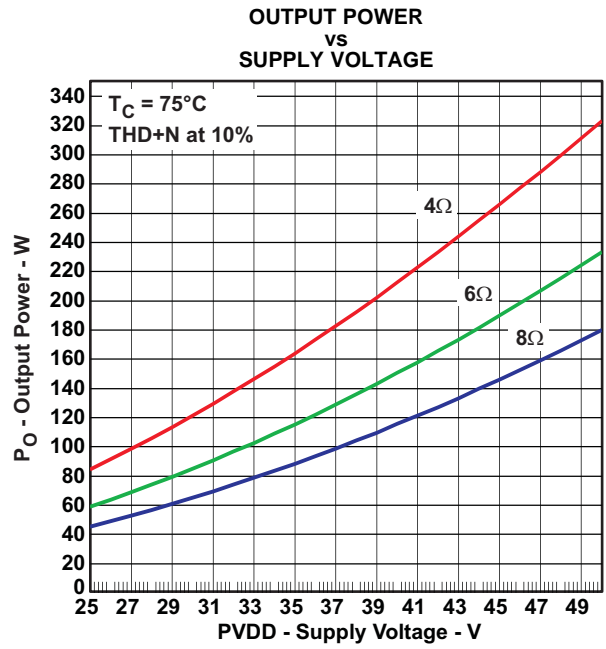

Figure 12.

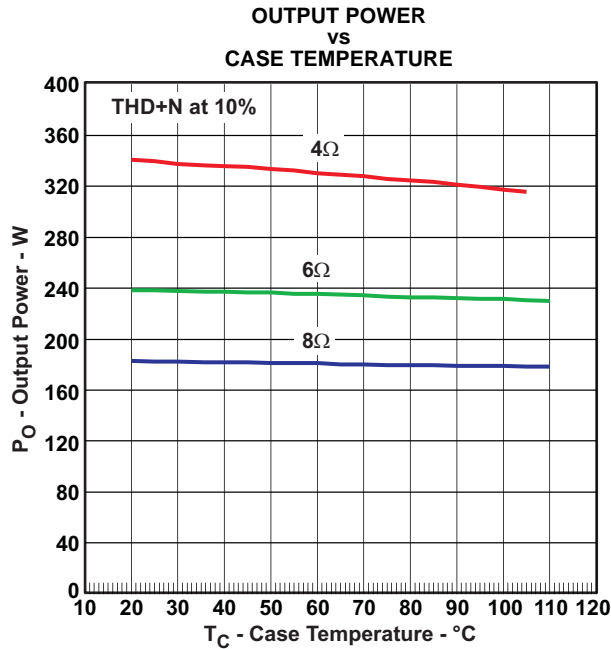

Figure 13.

APPLICATION INFORMATION

PCB MATERIAL RECOMMENDATION

FR-4 Glass Epoxy material with 2 oz. (70 μm) is recommended for use with the TAS5615. The use of this material can provide for higher power output, improved thermal performance, and better EMI margin (due to lower PCB trace inductance).

PVDD CAPACITOR RECOMMENDATION

The large capacitors used in conjunction with each full-bridge, are referred to as the PVDD Capacitors. These capacitors should be selected for proper voltage margin and adequate capacitance to support the power requirements. In practice, with a well designed system power supply, 1000 μF , 63 V will support more applications. The PVDD capacitors should be low ESR type because they are used in a circuit associated with high-speed switching.

DECOUPLING CAPACITOR RECOMMENDATIONS

In order to design an amplifier that has robust performance, passes regulatory requirements, and exhibits good audio performance, good quality decoupling capacitors should be used. In practice, X7R should be used in this application.

The voltage of the decoupling capacitors should be selected in accordance with good design practices. Temperature, ripple current, and voltage overshoot must be considered. This fact is particularly true in the selection of the 2.2 μF that is placed on the power supply to each half-bridge. It must withstand the voltage overshoot of the PWM switching, the heat generated by the amplifier during high power output, and the ripple current created by high power output. A minimum voltage rating of 63 V is required for use with a 50.0 V power supply.

SYSTEM DESIGN RECOMMENDATIONS

The following schematics and PCB layouts illustrate "best practices" in the use of the TAS5615.

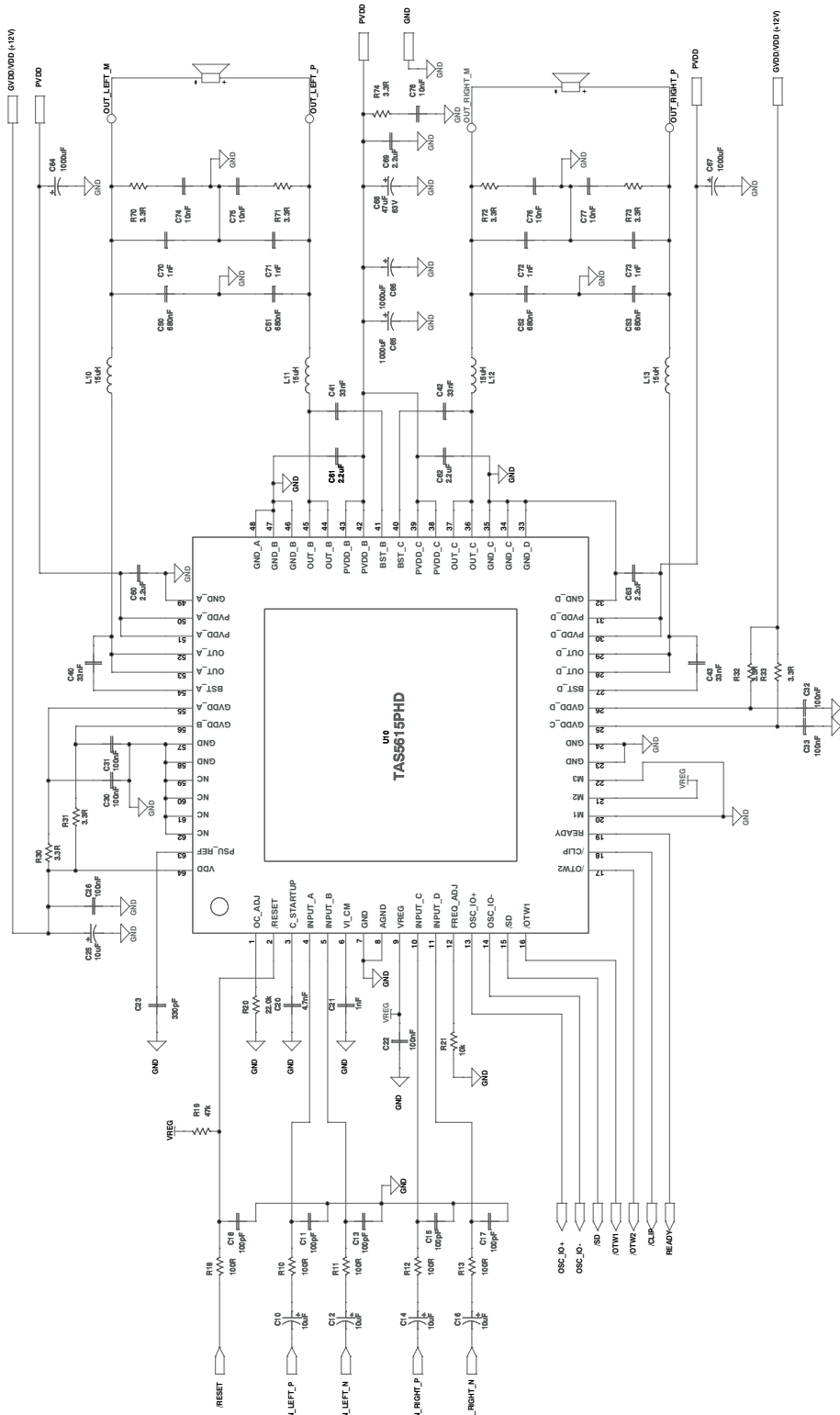

Figure 14. Typical Differential Input BTL Application With BD Modulation Filters

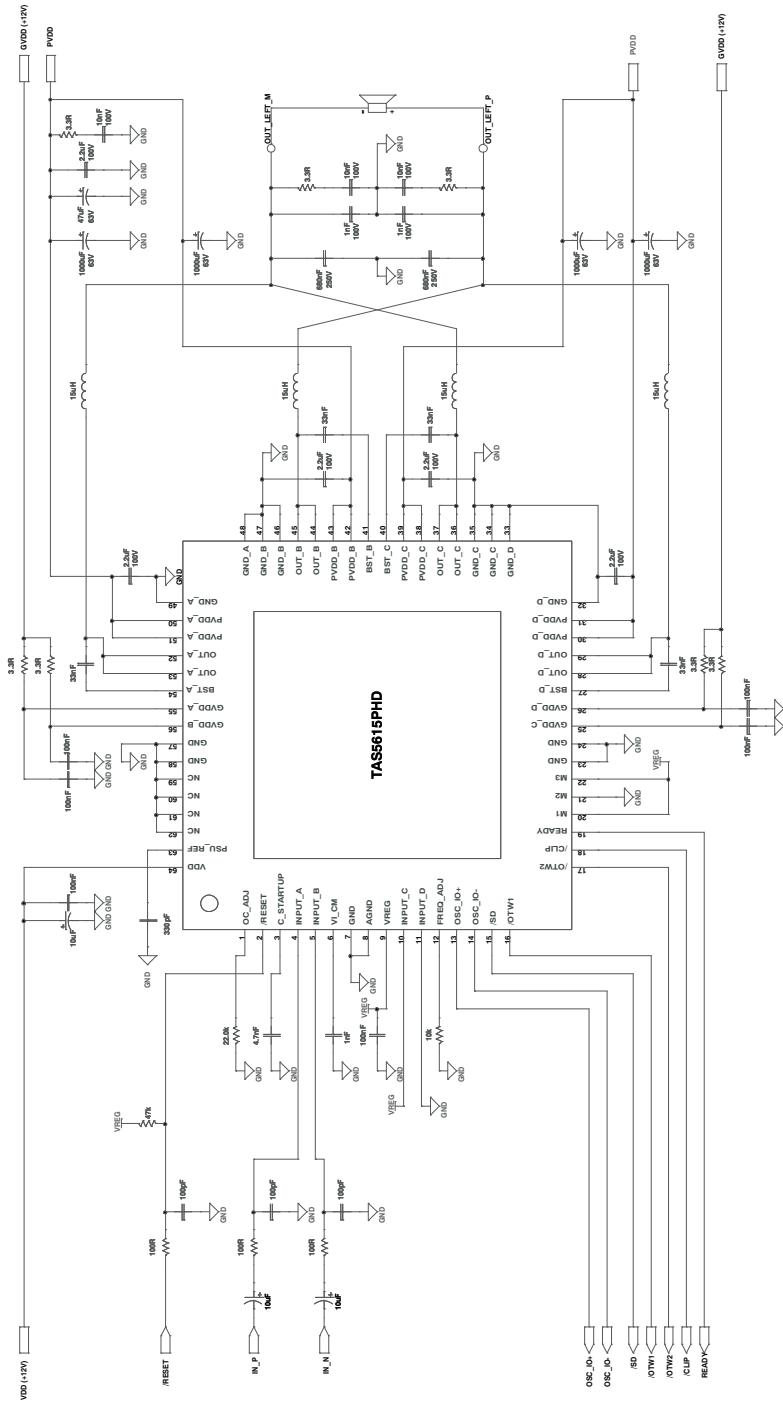

Figure 15. Typical Differential (2N) PBTl Application With BD Modulation Filters

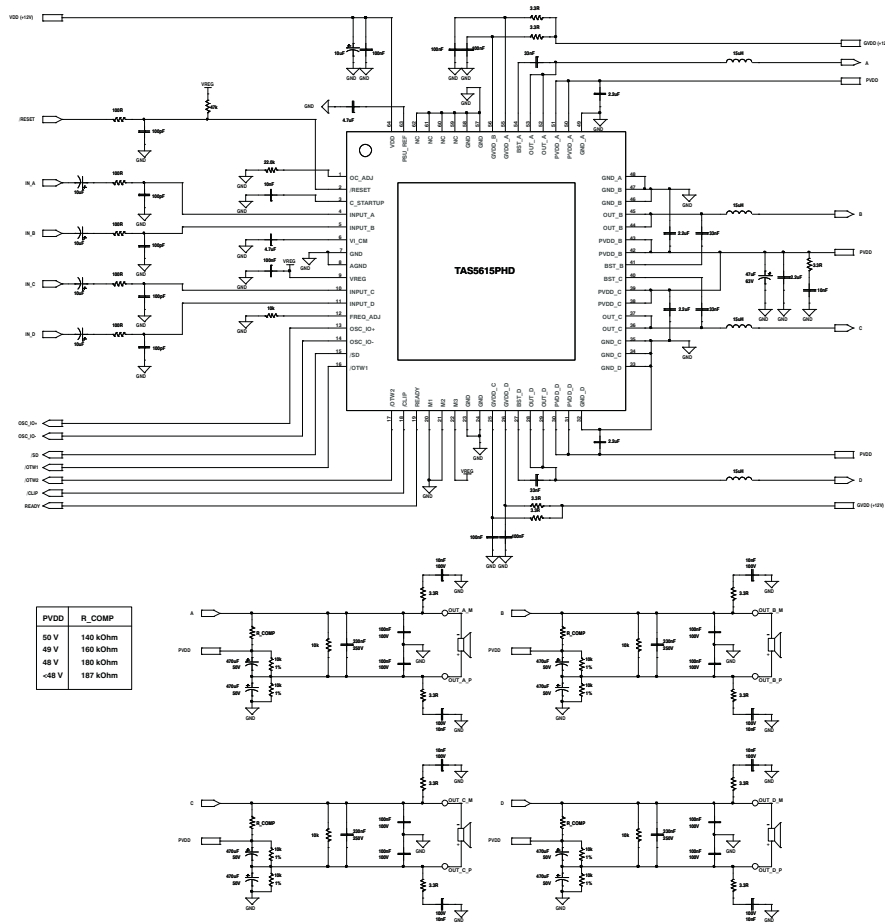

Figure 16. Typical SE Application

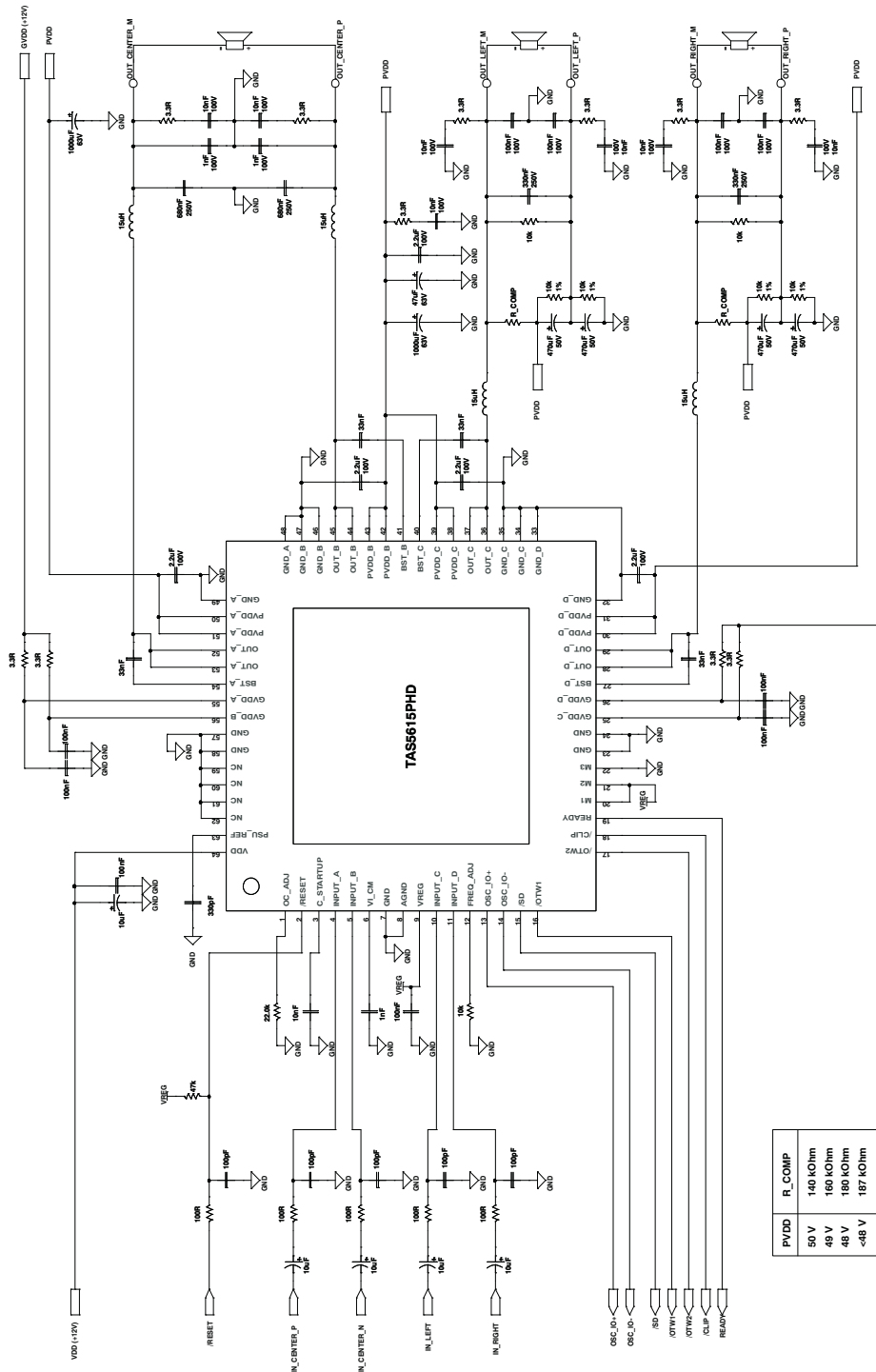

Figure 17. Typical 2.1 System Differential Input BTL and Unbalanced Input SE Application

THEORY OF OPERATION

POWER SUPPLIES

To facilitate system design, the TAS5615 needs only a 12V supply in addition to the (typical) 50V power-stage supply. An internal voltage regulator provides suitable voltage levels for the digital and low-voltage analog circuitry. Additionally, all circuitry requiring a floating voltage supply, e.g., the high-side gate drive, is accommodated by built-in bootstrap circuitry requiring only an external capacitor for each half-bridge.

In order to provide outstanding electrical and acoustical characteristics, the PWM signal path including gate drive and output stage is designed as identical, independent half-bridges. For this reason, each half-bridge has separate gate drive supply (GVDD_X), bootstrap pins (BST_X), and power-stage supply pins (PVDD_X). Furthermore, an additional pin (VDD) is provided as supply for all common circuits. Although supplied from the same 12V source, it is highly recommended to separate GVDD_A, GVDD_B, GVDD_C, GVDD_D, and VDD on the printed-circuit board (PCB) by RC filters (see application diagram for details). These RC filters provide the recommended high-frequency isolation. Special attention should be paid to placing all decoupling capacitors as close to their associated pins as possible. In general, inductance between the power supply pins and decoupling capacitors must be avoided. (See reference board documentation for additional information.)

For a properly functioning bootstrap circuit, a small ceramic capacitor must be connected from each bootstrap pin (BST_X) to the power-stage output pin (OUT_X). When the power-stage output is low, the bootstrap capacitor is charged through an internal diode connected between the gate-drive power-supply pin (GVDD_X) and the bootstrap pin. When the power-stage output is high, the bootstrap capacitor potential is shifted above the output potential and thus provides a suitable voltage supply for the high-side gate driver. In an application with PWM switching frequencies in the range from 300kHz to 400kHz, it is recommended to use 33nF ceramic capacitors, size 0603 or 0805, for the bootstrap supply. These 33nF capacitors ensure sufficient energy storage, even during minimal PWM duty cycles, to keep the high-side power stage FET (LDMOS) fully turned on during the remaining part of the PWM cycle.

Special attention should be paid to the power-stage power supply; this includes component selection, PCB placement, and routing. As indicated, each half-bridge has independent power-stage supply pins (PVDD_X). For optimal electrical performance, EMI compliance, and system reliability, it is important that each PVDD_X pin is decoupled with a 2.2μF ceramic capacitor placed as close as possible to each supply pin. It is recommended to follow the PCB layout of the TAS5615 reference design. For additional information on recommended power supply and required components, see the application diagrams in this data sheet.

The 12V supply should be from a low-noise, low-output-impedance voltage regulator. Likewise, the 50V power-stage supply is assumed to have low output impedance and low noise. The power-supply sequence is not critical as facilitated by the internal power-on-reset circuit. Moreover, the TAS5615 is fully protected against erroneous power-stage turn on due to parasitic gate charging. Thus, voltage-supply ramp rates (dV/dt) are non-critical within the specified range (see the [Recommended Operating Conditions](#) table of this data sheet).

SYSTEM POWER-UP/POWER-DOWN SEQUENCE

Powering Up

The TAS5615 does not require a power-up sequence. The outputs of the H-bridges remain in a high-impedance state until the gate-drive supply voltage (GVDD_X) and VDD voltage are above the undervoltage protection (UVP) voltage threshold (see the [Electrical Characteristics](#) table of this data sheet). Although not specifically required, it is recommended to hold $\overline{\text{RESET}}$ in a low state while powering up the device. This allows an internal circuit to charge the external bootstrap capacitors by enabling a weak pulldown of the half-bridge output.

Powering Down

The TAS5615 does not require a power-down sequence. The device remains fully operational as long as the gate-drive supply (GVDD_X) voltage and VDD voltage are above the undervoltage protection (UVP) voltage threshold (see the [Electrical Characteristics](#) table of this data sheet). Although not specifically required, it is a good practice to hold $\overline{\text{RESET}}$ low during power down, thus preventing audible artifacts including pops or clicks.

ERROR REPORTING

The \overline{SD} , \overline{OTW} , $\overline{OTW1}$ and $\overline{OTW2}$ pins are active-low, open-drain outputs. Their function is for protection-mode signaling to a PWM controller or other system-control device.

Any fault resulting in device shutdown is signaled by the \overline{SD} pin going low. Likewise, \overline{OTW} and $\overline{OTW2}$ goes low when the device junction temperature exceeds 125°C and $\overline{OTW1}$ goes low when the junction temperature exceeds 100°C (see the following table).

\overline{SD}	$\overline{OTW1}$	$\overline{OTW2}, \overline{OTW}$	DESCRIPTION
0	0	0	Overtemperature (OTE) or overload (OLP) or undervoltage (UVP) Junction temperature higher than 125°C (overtemperature warning)
0	0	1	Overload (OLP) or undervoltage (UVP). Junction temperature higher than 100°C (overtemperature warning)
0	1	1	Overload (OLP) or undervoltage (UVP). Junction temperature lower than 100°C
1	0	0	Junction temperature higher than 125°C (overtemperature warning)
1	0	1	Junction temperature higher than 100°C (overtemperature warning)
1	1	1	Junction temperature lower than 100°C and no OLP or UVP faults (normal operation)

Note that asserting either \overline{RESET} low forces the \overline{SD} signal high, independent of faults being present. TI recommends monitoring the \overline{OTW} signal using the system microcontroller and responding to an overtemperature warning signal by, e.g., turning down the volume to prevent further heating of the device resulting in device shutdown (OTE).

To reduce external component count, an internal pullup resistor to 3.3V is provided on both \overline{SD} and \overline{OTW} outputs. Level compliance for 5V logic can be obtained by adding external pullup resistors to 5 V (see the Electrical Characteristics section of this data sheet for further specifications).

DEVICE PROTECTION SYSTEM

The TAS5615 contains advanced protection circuitry carefully designed to facilitate system integration and ease of use, as well as to safeguard the device from permanent failure due to a wide range of fault conditions such as short circuits, overload, overtemperature, and undervoltage. The TAS5615 responds to a fault by immediately setting the power stage in a high-impedance (Hi-Z) state and asserting the \overline{SD} pin low. In situations other than overload and overtemperature error (OTE), the device automatically recovers when the fault condition has been removed, i.e., the supply voltage has increased.

The device will function on errors, as shown in the following table

BTL	MODE	PBTL	MODE	SE	MODE
LOCAL ERROR IN	TURNS OFF	LOCAL ERROR IN	TURNS OFF	LOCAL ERROR IN	TURNS OFF
A	A+B	A	A+B+C+D	A	A+B
B		B		B	
C	C+D	C		C	C+D
D		D		D	

Bootstrap UVP does not shutdown according to the table, it shuts down the respective halfbridge.

PIN-TO-PIN SHORT CIRCUIT PROTECTION (PPSC)

The PPSC detection system protects the device from permanent damage in the case that a power output pin (OUT_X) is shorted to GND_X or PVDD_X. For comparison, the OC protection system detects an overcurrent after the demodulation filter where PPSC detects shorts directly at the pin before the filter. PPSC detection is performed at startup i.e. when VDD is supplied, consequently a short to either GND_X or PVDD_X after system startup will not activate the PPSC detection system. When PPSC detection is activated by a short on the output, all half bridges are kept in a Hi-Z state until the short is removed, the device then continues the startup sequence and starts switching. The detection is controlled globally by a two step sequence. The first step ensures that there are no shorts from OUT_X to GND_X, the second step tests that there are no shorts from OUT_X to PVDD_X. The total duration of this process is roughly proportional to the capacitance of the output LC filter. The

typical duration is $< 15\text{ms}/\mu\text{F}$. While the PPSC detection is in progress, $\overline{\text{SD}}$ is kept low, and the device will not react to changes applied to the RESET pins. If no shorts are present the PPSC detection passes, and $\overline{\text{SD}}$ is released. A device reset will not start a new PPSC detection. PPSC detection is enabled in BTL and PBTL output configurations, the detection is not performed in SE mode. To make sure not to trip the PPSC detection system it is recommended not to insert resistive load to GND_X or PVDD_X.

OVERTEMPERATURE PROTECTION

The two different package options has individual over temperature protection schemes.

PHD Package

The TAS5615 PHD package option has a three-level temperature-protection system that asserts an active-low warning signal ($\overline{\text{OTW1}}$) when the device junction temperature exceeds 100°C (typical), ($\overline{\text{OTW2}}$) when the device junction temperature exceeds 125°C (typical) and, if the device junction temperature exceeds 155°C (typical), the device is put into thermal shutdown, resulting in all half-bridge outputs being set in the high-impedance (Hi-Z) state and $\overline{\text{SD}}$ being asserted low. OTE is latched in this case. To clear the OTE latch, $\overline{\text{RESET}}$ must be asserted. Thereafter, the device resumes normal operation.

DKD Package

The TAS5615 DKD package option has a two-level temperature-protection system that asserts an active-low warning signal ($\overline{\text{OTW}}$) when the device junction temperature exceeds 125°C (typical) and, if the device junction temperature exceeds 155°C (typical), the device is put into thermal shutdown, resulting in all half-bridge outputs being set in the high-impedance (Hi-Z) state and $\overline{\text{SD}}$ being asserted low. OTE is latched in this case. To clear the OTE latch, $\overline{\text{RESET}}$ must be asserted. Thereafter, the device resumes normal operation.

UNDERVOLTAGE PROTECTION (UVP) AND POWER-ON RESET (POR)

The UVP and POR circuits of the TAS5615 fully protect the device in any power-up/down and brownout situation. While powering up, the POR circuit resets the overload circuit (OLP) and ensures that all circuits are fully operational when the GVDD_X and VDD supply voltages reach stated in the [Electrical Characteristics](#) table. Although GVDD_X and VDD are independently monitored, a supply voltage drop below the UVP threshold on any VDD or GVDD_X pin results in all half-bridge outputs immediately being set in the high-impedance (Hi-Z) state and $\overline{\text{SD}}$ being asserted low. The device automatically resumes operation when all supply voltages have increased above the UVP threshold.

DEVICE RESET

When RESET is asserted low, all power-stage FETs in the four half-bridges are forced into a high-impedance (Hi-Z) state.

In BTL modes, to accommodate bootstrap charging prior to switching start, asserting the reset input low enables weak pulldown of the half-bridge outputs. In the SE mode, the output is forced into a high impedance state when asserting the reset input low.

Asserting reset input low removes any fault information to be signalled on the $\overline{\text{SD}}$ output, i.e., $\overline{\text{SD}}$ is forced high. A rising-edge transition on reset input allows the device to resume operation after an overload fault. To ensure thermal reliability, the rising edge of reset must occur no sooner than 4 ms after the falling edge of $\overline{\text{SD}}$.

SYSTEM DESIGN CONSIDERATION

A rising-edge transition on reset input allows the device to execute the startup sequence and starts switching.

Apply only audio when the state of READY is high that will start and stop the amplifier without having audible artifacts that is heard in the output transducers. If an overcurrent protection event is introduced the READY signal goes low hence filtering is needed if the signal is intended for audio muting in non microcontroller systems.

The CLIP signal is indicating that the output is approaching clipping. The signal can be used to either an audio volume decrease or intelligent power supply controlling a low and a high rail.

The device is inverting the audio signal from input to output.

The VREG pin is not recommended to be used as a voltage source for external circuitry.

OSCILLATOR

The oscillator frequency can be trimmed by external control of the `FREQ_ADJ` pin.

To reduce interference problems while using radio receiver tuned within the AM band, the switching frequency can be changed from nominal to lower values. These values should be chosen such that the nominal and the lower value switching frequencies together results in the fewest cases of interference throughout the AM band. can be selected by the value of the `FREQ_ADJ` resistor connected to `AGND` in master mode.

For slave mode operation, turn of the oscillator by pulling the `FREQ_ADJ` pin to `VREG`. This configures the `OSC_I/O` pins as inputs and needs to be slaved from an external clock.

PRINTED CIRCUIT BOARD RECOMMENDATION

Use an unbroken ground plane to have good low impedance and inductance return path to the power supply for power and audio signals. PCB layout, audio performance and EMI are linked closely together. The circuit contains high fast switching currents; therefore, care must be taken to prevent damaging voltage spikes. Routing the audio input should be kept short and together with the accompanied audio source ground. A local ground area underneath the device is important to keep solid to minimize ground bounce.

Netlist for this printed circuit board is generated from the schematic in [Figure 14](#).

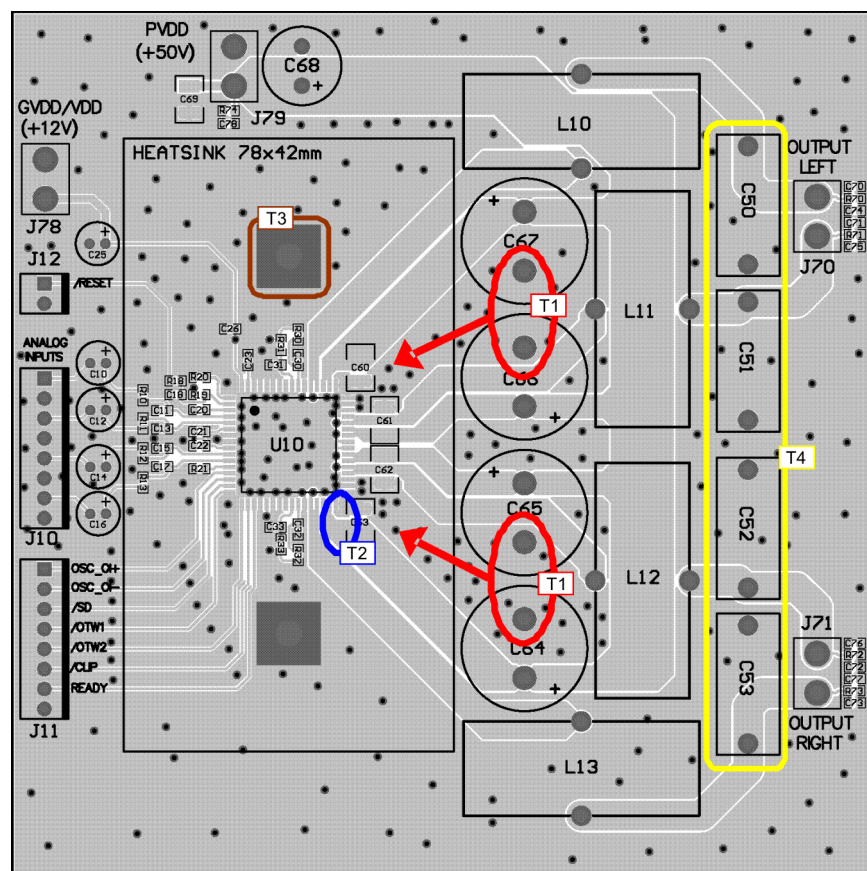

Note T1: PVDD decoupling bulk capacitors C60-C64 should be as close as possible to the PVDD and `GND_X` pins, the heat sink sets the distance. Wide traces should be routed on the top layer with direct connection to the pins and without going through vias. No vias or traces should be blocking the current path.

Note T2: Close decoupling of PVDD with low impedance X7R ceramic capacitors is placed under the heat sink and close to the pins.

Note T3: Heat sink needs to have a good connection to PCB ground.

Note T4: Output filter capacitors must be linear in the applied voltage range preferable metal film types.

Figure 18. Printed Circuit Board - Top Layer

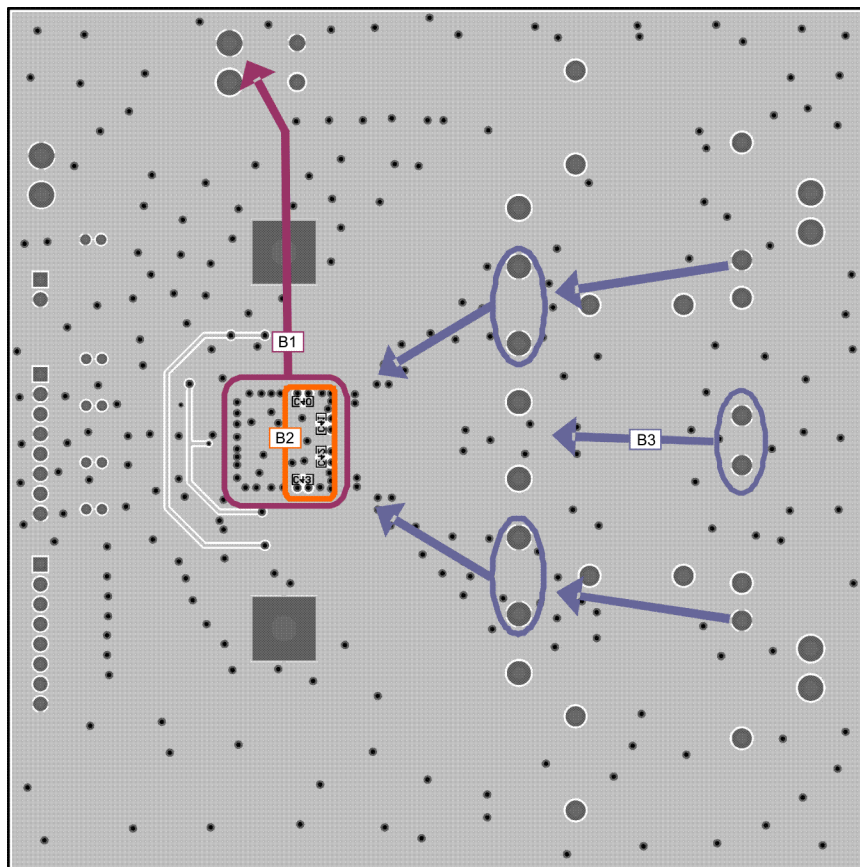

Note B1: It is important to have a direct low impedance return path for high current back to the power supply. Keep impedance low from top to bottom side of PCB through a lot of ground vias.

Note B2: Bootstrap low impedance X7R ceramic capacitors placed on bottom side providing a short low inductance current loop.

Note B3: Return currents from bulk capacitors and output filter capacitors.

Figure 19. Printed Circuit Board - Bottom Layer

PACKAGING INFORMATION

Orderable Device	Status ⁽¹⁾	Package Type	Package Drawing	Pins	Package Qty	Eco Plan ⁽²⁾	Lead/Ball Finish	MSL Peak Temp ⁽³⁾
TAS5615DKD	ACTIVE	HSSOP	DKD	44	29	Green (RoHS & no Sb/Br)	CU NIPDAU	Level-4-260C-72 HR
TAS5615DKDR	ACTIVE	HSSOP	DKD	44	500	Green (RoHS & no Sb/Br)	CU NIPDAU	Level-4-260C-72 HR
TAS5615PHD	PREVIEW	HTQFP	PHD	64	90	TBD	Call TI	Call TI
TAS5615PHDR	PREVIEW	HTQFP	PHD	64	1000	TBD	Call TI	Call TI

⁽¹⁾ The marketing status values are defined as follows:

ACTIVE: Product device recommended for new designs.

LIFEBUY: TI has announced that the device will be discontinued, and a lifetime-buy period is in effect.

NRND: Not recommended for new designs. Device is in production to support existing customers, but TI does not recommend using this part in a new design.

PREVIEW: Device has been announced but is not in production. Samples may or may not be available.

OBSOLETE: TI has discontinued the production of the device.

⁽²⁾ Eco Plan - The planned eco-friendly classification: Pb-Free (RoHS), Pb-Free (RoHS Exempt), or Green (RoHS & no Sb/Br) - please check <http://www.ti.com/productcontent> for the latest availability information and additional product content details.

TBD: The Pb-Free/Green conversion plan has not been defined.

Pb-Free (RoHS): TI's terms "Lead-Free" or "Pb-Free" mean semiconductor products that are compatible with the current RoHS requirements for all 6 substances, including the requirement that lead not exceed 0.1% by weight in homogeneous materials. Where designed to be soldered at high temperatures, TI Pb-Free products are suitable for use in specified lead-free processes.

Pb-Free (RoHS Exempt): This component has a RoHS exemption for either 1) lead-based flip-chip solder bumps used between the die and package, or 2) lead-based die adhesive used between the die and leadframe. The component is otherwise considered Pb-Free (RoHS compatible) as defined above.

Green (RoHS & no Sb/Br): TI defines "Green" to mean Pb-Free (RoHS compatible), and free of Bromine (Br) and Antimony (Sb) based flame retardants (Br or Sb do not exceed 0.1% by weight in homogeneous material)

⁽³⁾ MSL, Peak Temp. -- The Moisture Sensitivity Level rating according to the JEDEC industry standard classifications, and peak solder temperature.

Important Information and Disclaimer:The information provided on this page represents TI's knowledge and belief as of the date that it is provided. TI bases its knowledge and belief on information provided by third parties, and makes no representation or warranty as to the accuracy of such information. Efforts are underway to better integrate information from third parties. TI has taken and continues to take reasonable steps to provide representative and accurate information but may not have conducted destructive testing or chemical analysis on incoming materials and chemicals. TI and TI suppliers consider certain information to be proprietary, and thus CAS numbers and other limited information may not be available for release.

In no event shall TI's liability arising out of such information exceed the total purchase price of the TI part(s) at issue in this document sold by TI to Customer on an annual basis.

TAPE AND REEL INFORMATION



QUADRANT ASSIGNMENTS FOR PIN 1 ORIENTATION IN TAPE



*All dimensions are nominal

Device	Package Type	Package Drawing	Pins	SPQ	Reel Diameter (mm)	Reel Width W1 (mm)	A0 (mm)	B0 (mm)	K0 (mm)	P1 (mm)	W (mm)	Pin1 Quadrant
TAS5615DKDR	HSSOP	DKD	44	500	330.0	24.4	14.7	16.4	4.0	20.0	24.0	Q1

TAPE AND REEL BOX DIMENSIONS



*All dimensions are nominal

Device	Package Type	Package Drawing	Pins	SPQ	Length (mm)	Width (mm)	Height (mm)
TAS5615DKDR	HSSOP	DKD	44	500	346.0	346.0	41.0

MECHANICAL DATA

PHD (S-PQFP-G64) PowerPAD™ PLASTIC QUAD FLATPACK (DIE DOWN)

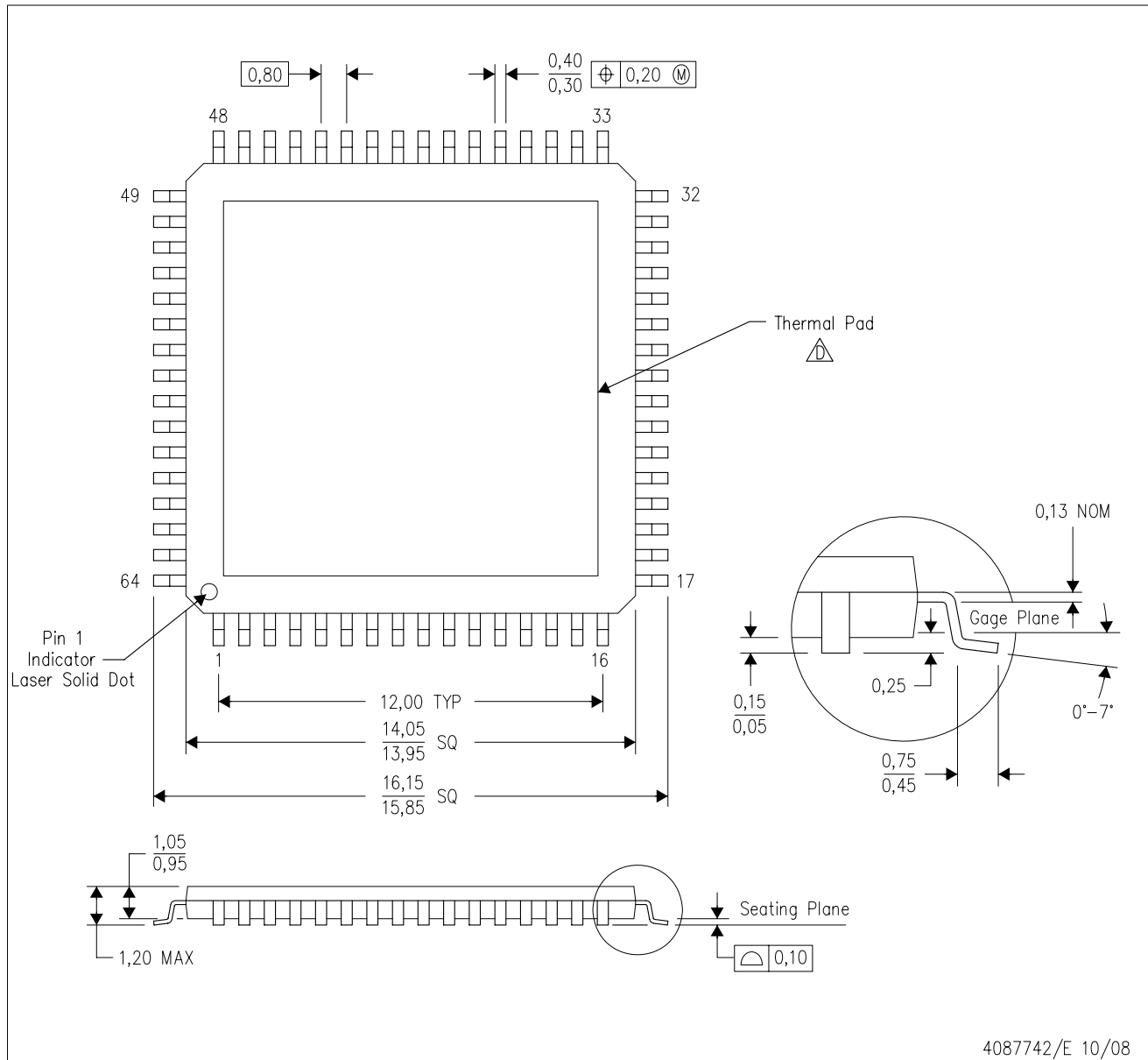

- NOTES:
- A. All linear dimensions are in millimeters. Dimensioning and tolerancing per ASME Y14.5M-1994.
 - B. This drawing is subject to change without notice.
 - C. Body dimensions do not include mold flash or protrusion
 - △ This package is designed to be attached directly to an external heatsink. Refer to Technical Brief, PowerPad Thermally Enhanced Package, Texas Instruments Literature No. SLMA002 for information regarding recommended board layout. This document is available at www.ti.com <<http://www.ti.com>>. See the product data sheet for details regarding the exposed thermal pad dimensions.
 - E. Falls within JEDEC MS-026

PowerPAD is a trademark of Texas Instruments.

IMPORTANT NOTICE

Texas Instruments Incorporated and its subsidiaries (TI) reserve the right to make corrections, modifications, enhancements, improvements, and other changes to its products and services at any time and to discontinue any product or service without notice. Customers should obtain the latest relevant information before placing orders and should verify that such information is current and complete. All products are sold subject to TI's terms and conditions of sale supplied at the time of order acknowledgment.

TI warrants performance of its hardware products to the specifications applicable at the time of sale in accordance with TI's standard warranty. Testing and other quality control techniques are used to the extent TI deems necessary to support this warranty. Except where mandated by government requirements, testing of all parameters of each product is not necessarily performed.

TI assumes no liability for applications assistance or customer product design. Customers are responsible for their products and applications using TI components. To minimize the risks associated with customer products and applications, customers should provide adequate design and operating safeguards.

TI does not warrant or represent that any license, either express or implied, is granted under any TI patent right, copyright, mask work right, or other TI intellectual property right relating to any combination, machine, or process in which TI products or services are used. Information published by TI regarding third-party products or services does not constitute a license from TI to use such products or services or a warranty or endorsement thereof. Use of such information may require a license from a third party under the patents or other intellectual property of the third party, or a license from TI under the patents or other intellectual property of TI.

Reproduction of TI information in TI data books or data sheets is permissible only if reproduction is without alteration and is accompanied by all associated warranties, conditions, limitations, and notices. Reproduction of this information with alteration is an unfair and deceptive business practice. TI is not responsible or liable for such altered documentation. Information of third parties may be subject to additional restrictions.

Resale of TI products or services with statements different from or beyond the parameters stated by TI for that product or service voids all express and any implied warranties for the associated TI product or service and is an unfair and deceptive business practice. TI is not responsible or liable for any such statements.

TI products are not authorized for use in safety-critical applications (such as life support) where a failure of the TI product would reasonably be expected to cause severe personal injury or death, unless officers of the parties have executed an agreement specifically governing such use. Buyers represent that they have all necessary expertise in the safety and regulatory ramifications of their applications, and acknowledge and agree that they are solely responsible for all legal, regulatory and safety-related requirements concerning their products and any use of TI products in such safety-critical applications, notwithstanding any applications-related information or support that may be provided by TI. Further, Buyers must fully indemnify TI and its representatives against any damages arising out of the use of TI products in such safety-critical applications.

TI products are neither designed nor intended for use in military/aerospace applications or environments unless the TI products are specifically designated by TI as military-grade or "enhanced plastic." Only products designated by TI as military-grade meet military specifications. Buyers acknowledge and agree that any such use of TI products which TI has not designated as military-grade is solely at the Buyer's risk, and that they are solely responsible for compliance with all legal and regulatory requirements in connection with such use.

TI products are neither designed nor intended for use in automotive applications or environments unless the specific TI products are designated by TI as compliant with ISO/TS 16949 requirements. Buyers acknowledge and agree that, if they use any non-designated products in automotive applications, TI will not be responsible for any failure to meet such requirements.

Following are URLs where you can obtain information on other Texas Instruments products and application solutions:

Products

Amplifiers	amplifier.ti.com
Data Converters	dataconverter.ti.com
DLP® Products	www.dlp.com
DSP	dsp.ti.com
Clocks and Timers	www.ti.com/clocks
Interface	interface.ti.com
Logic	logic.ti.com
Power Mgmt	power.ti.com
Microcontrollers	microcontroller.ti.com
RFID	www.ti-rfid.com
RF/IF and ZigBee® Solutions	www.ti.com/lprf

Applications

Audio	www.ti.com/audio
Automotive	www.ti.com/automotive
Broadband	www.ti.com/broadband
Digital Control	www.ti.com/digitalcontrol
Medical	www.ti.com/medical
Military	www.ti.com/military
Optical Networking	www.ti.com/opticalnetwork
Security	www.ti.com/security
Telephony	www.ti.com/telephony
Video & Imaging	www.ti.com/video
Wireless	www.ti.com/wireless

Mailing Address: Texas Instruments, Post Office Box 655303, Dallas, Texas 75265
Copyright © 2009, Texas Instruments Incorporated