

TOSHIBA

TB62731FU

TOSHIBA BiCD INTEGRATED CIRCUIT SILICON MONOLITHIC

T B 6 2 7 3 1 F U

Step up DC-DC converter for LEDs

FEATURES

- The new driver incorporates a Pulse Current Drive Mode that raises efficiency over 90% while driving up to six white LEDs in a serial connection.
- In Direct Current Drive Mode white LEDs can be driven with very low noise and efficiencies over 85%.
- The TB62731FU uses bi-cadmium (BiCD) process technology. This new methodology allows for a reduction in the external component count therefore lowering costs and improving battery life.
- Newly developed temperature derating technology predicts environmental temperature, including heat dissipating from the driver IC itself, and adjusts current to optimize light emission.
- Ultra compact 6-pin SOT23 package.
- Ability to drive all wavelengths and materials.
- +3.0V to +5.5V supply voltage
- Adjustable output current (Up to 320mW output power) 20mA driving current can be supply for LEDs with 16V total Vf
- Internal switching MOSFET (1.5 ohm typ)
- Shutdown function

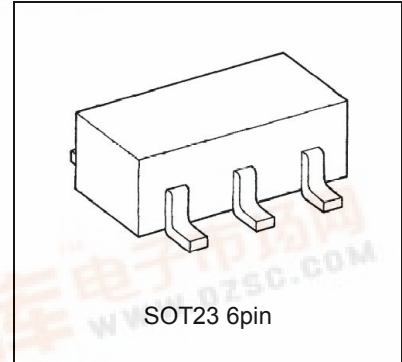

- TOSHIBA is continually working to improve the quality and reliability of its products. Nevertheless, semiconductor devices in general can malfunction or fail due to their inherent electrical sensitivity and vulnerability to physical stress. It is the responsibility of the buyer, when utilizing TOSHIBA products, to comply with the standards of safety in making a safe design for the entire system, and to avoid situations in which a malfunction or failure of such TOSHIBA products could cause loss of human life, bodily injury or damage to property.
- In developing your designs, please ensure that TOSHIBA products are used within specified operating ranges as set forth in the most recent TOSHIBA products specifications. Also, please keep in mind the precautions and conditions set forth in the "Handling Guide for Semiconductor Devices," or "TOSHIBA Semiconductor Reliability Handbook" etc..
- The TOSHIBA products listed in this document are intended for usage in general electronics applications (computer, personal equipment, office equipment, measuring equipment, industrial robotics, domestic appliances, etc.). These TOSHIBA products are neither intended nor warranted for usage in equipment that requires extraordinarily high quality and/or reliability or a malfunction or failure of which may cause loss of human life or bodily injury ("Unintended Usage"). Unintended Usages include atomic energy control instruments, airplane or spaceship instruments, transportation instruments, traffic signal instruments, combustion control instruments, medical instruments, all types of safety devices, etc. Unintended Usage of TOSHIBA products listed in this document shall be made at the customer's own risk.
- The products described in this document are subject to the foreign exchange and foreign trade laws.
- The information contained herein is presented only as a guide for the applications of our products. No responsibility is assumed by TOSHIBA CORPORATION for any infringements of intellectual property or other rights of the third parties, which may result from its use. No license is granted by implication or otherwise under any intellectual property or other rights of TOSHIBA CORPORATION or others.

Available from:

Marktech Optoelectronics
120 Broadway • Menands, NY 12203
800.984.5337 FAX: 518.432.7454
Website: www.marktechopto.com
Email: info@marktechopto.com

marktech
optoelectronics

Block Diagram

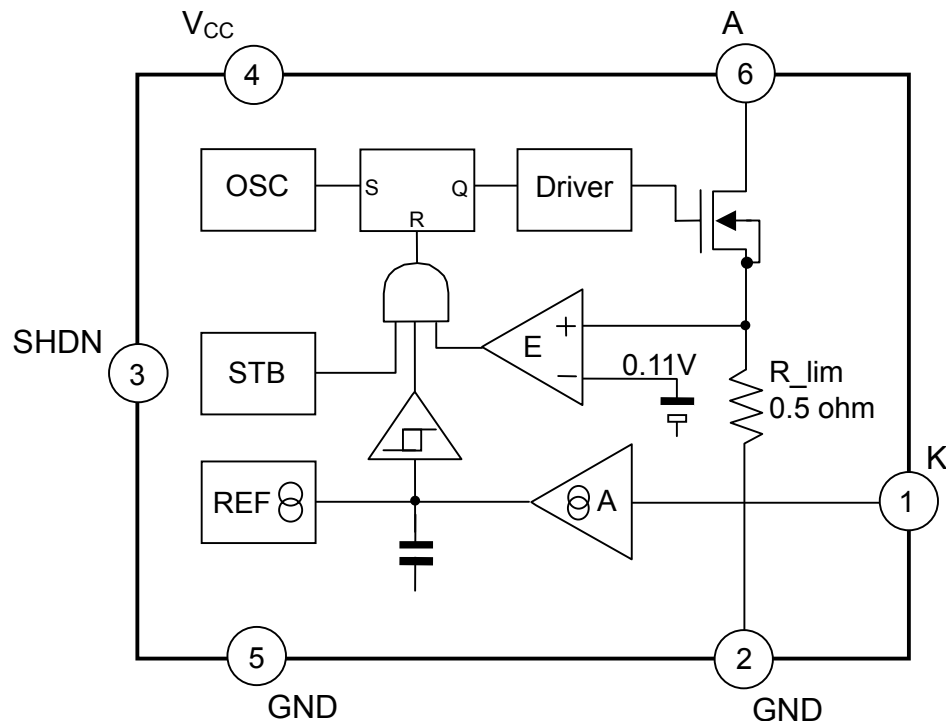

Pin Assignment

PIN NO.	SYMBOL	FUNCTION
1	K	Feedback input pin. Connect to the external LED driving current-sense resistor(R_{sens}).
2,5	GND	Ground pin
3	SHDN	Active "Low", shutdown control input pin. TB72731FU falls into shutdown mode, when SHDN=L.
4	VCC	Supply voltage input pin. Bypass this pin with a capacitor to ground as close to the device as possible.
6	A	Switching pin. Inductor connection to the Drain of internal N channel MOSFET.

Both GND pins must be connected to external Ground.

Absolute Maximum Ratings (Ta = 25°C)

PARAMETER	SYMBOL	RATING	UNIT
Power Supply Voltage	VCC	-0.3 ~ +6.0	V
Input Voltage	VIN	-0.3 ~ VCC+0.3V	V
Anode Current	I(A)	300	mA
Anode Voltage	V(A)	-0.3~+30	V
Power Dissipation	Pd	0.41	W
		0.47	
Saturated Thermal Resistance	Rth(j-a)1	300	°C/W
	Rth(j-a)1	260* ¹	
Operating Temperature Range	Topr	-40 ~ 85	°C
Storage Temperature Range	Tstg	-40 ~ +150	°C
Junction Temperature	Tj	+125	°C

<Note>

*1: Derate 3.8mW/°C above +25°C

Electrical Characteristics

(V_{CC}=3.0V~5.5V, Ta = +25°C, unless otherwise specified.)

PARAMETER	SYMBOL	TEST CONDITION	MIN.	TYP.	MAX.	UNIT
Supply Voltage	VCC		3.0		5.5	V
Supply Current	ICC(ON)	VCC=3.6V		600	900	uA
Quiescent Current	ICC(SHDN)	SHDN=GND			0.5	uA
SHDN Input Current	I_SHDN	SHDN=VCC		4.2	7	uA
Internal MOSFET ON-Resistance	Ron	I(A)=220mA or less, including R_lim		2.0	2.5	ohm
Anode Voltage	V(A)				30	V
Anode Current	I(A)			220		mA
Anode Leak Current	IOZ(A)	SHDN=GND		0.5	1	uA
LED Current (average)	Io(K)	R_sens=1.8 ohm	18* ¹	20* ¹	22* ¹	mA
Derating Function Start Temperature	Tder	Io(K)=20mA, Ta=25°C		(45)* ²		°C

<Note>

*1: See figure of “LED current vs. Feedback resistance”

*2: The specification in parenthesis is not tested. For design purpose, current derating should be considered to start at Tj=45°C.

Available from:

Marktech Optoelectronics
 120 Broadway • Menands, NY 12203
 800.984.5337 FAX: 518.432.7454
 Website: www.marktechopto.com
 Email: info@marktechopto.com



Typical Performance Characteristics

Supply Current vs. Supply Voltage
(Normal Operation)

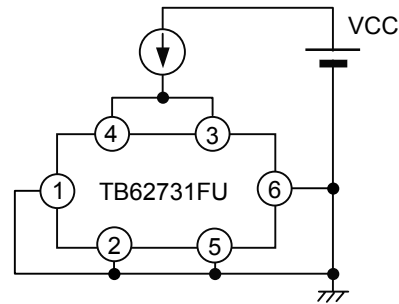
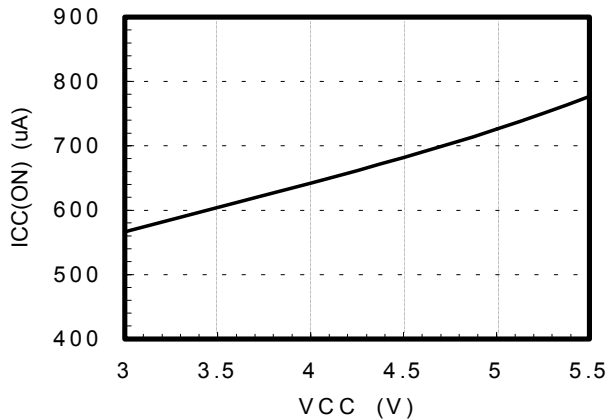

Supply Current vs. Supply Voltage
(Shutdown Mode)

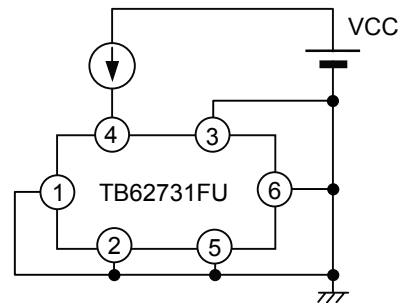
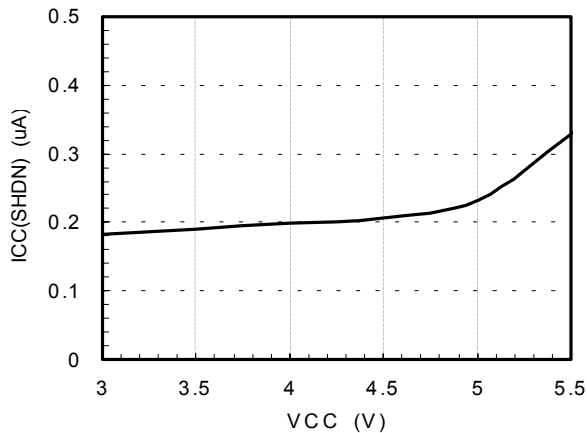

Switching Frequency vs. Supply Voltage

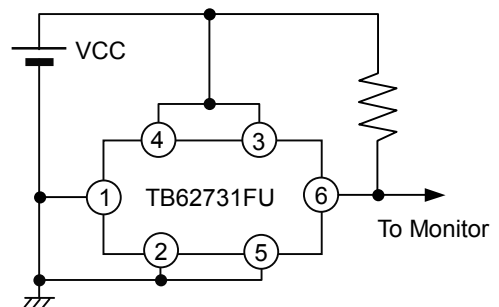
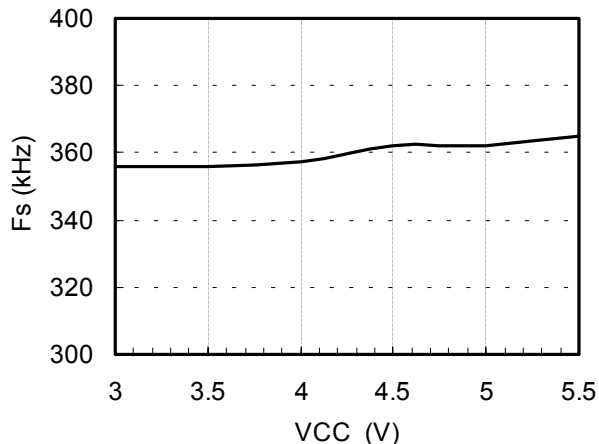

Available from:
 Marktech Optoelectronics
 120 Broadway • Menands, NY 12203
 800.984.5337 FAX: 518.432.7454
 Website: www.marktechopto.com
 Email: info@marktechopto.com



Operational Description

TB62731FU is a pulse-skipping converter that uses a combined control scheme of voltage feedback loop and current limited feedback loop to operate constant LED driving current. Operation can be easily understood by referring to the Block Diagram and Switching Waveforms.

The internal MOSFET is turned on when amplifier A senses that the average voltage at R_sens is lower than REF level. The N-channel MOSFET stays “turned on” until either the switching current peak reaches 220mA(typ), or the oscillator automatically turns it off at its maximum on-duty (83.3%). Once turned off, the MOSFET keeps off during the off-time. Subsequently, if the R_sens voltage is still lower than reference level, another switching cycle is started. Otherwise, the internal MOSFET remains turned off as long as the average R_sens voltage is higher than reference level.

[Shutdown Mode]

The TB62731FU falls into shutdown mode, when SHDN="L". In shutdown mode, the reference, control circuitry, oscillator and internal switching MOSFET are stopped and current consumption is reduced below 0.5uA. Connect SHDN to "VCC" for normal operation.

Switching Waveforms Illustration

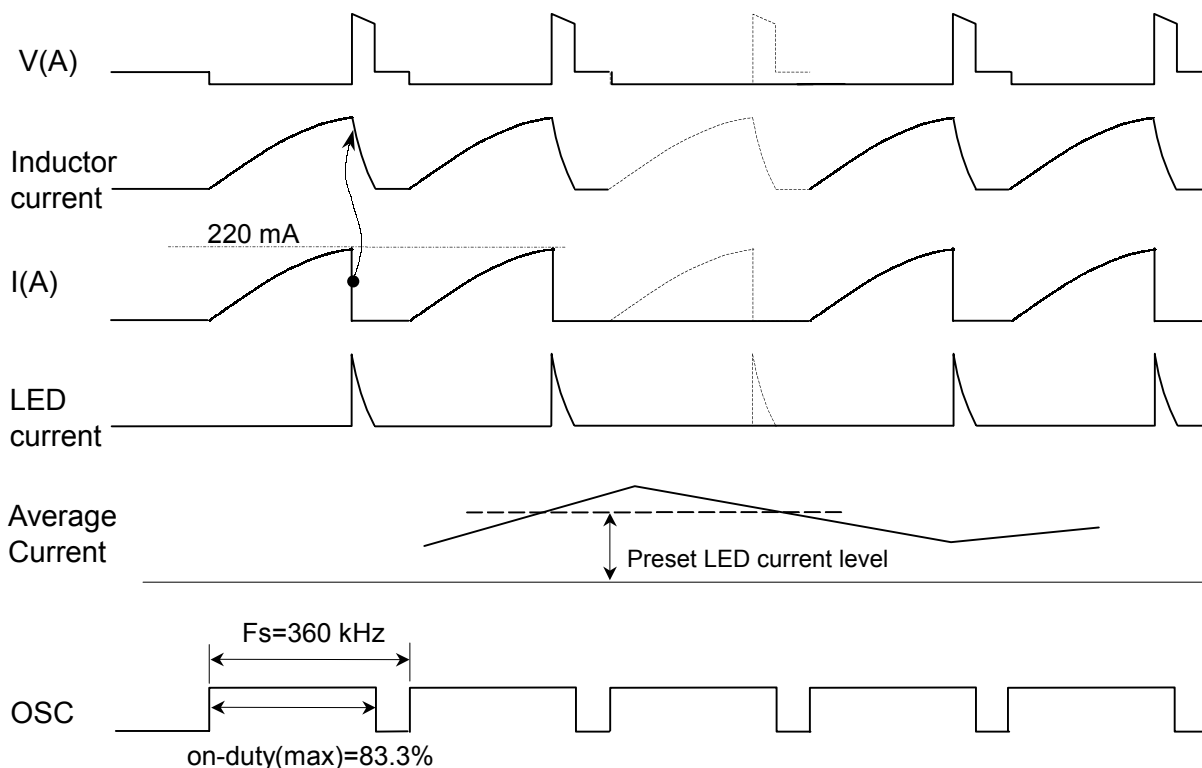

Available from:
Marktech Optoelectronics
120 Broadway • Menands, NY 12203
800.984.5337 FAX: 518.432.7454
Website: www.marktechopto.com
Email: info@marktechopto.com



[Driving Current Derating Function]

In order to avoid application problems, it is important to stay within the LED Lamps maximum ratings. This is especially critical when determining the maximum allowable driving current, which needs to be derated depending on atmospheric temperature. The TB62731FU has a built-in current derating function that helps light LED lamps safely and efficiently.

TB62731FU's driving current derating function is designed to start working at 45°C in T_j as shown in Figure 1. When the driving current is 20mA, derating is expected to start approximately at 25°C in T_a . The difference between T_j and T_a depends on LED driving current, IC mounting conditions, PCB patterns, cooling conditions. The initial driving current level must be set carefully so as not to exceed the absolute maximum ratings of LEDs.

With Toshiba's original derating function the TB62731FU can supply a higher LED driving current thus eliminating current limitations in high temperatures. Competitive ICs do not have this function, therefore this feature will contribute to a reduction in the amount of LED lamps used.

FIGURE 1

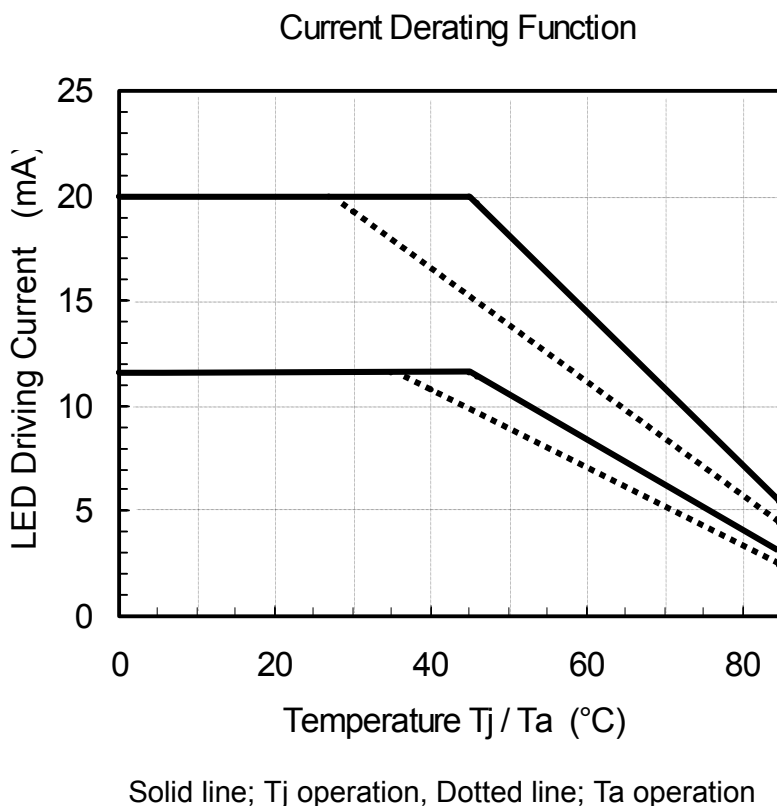

Available from:
Marktech Optoelectronics
120 Broadway • Menands, NY 12203
800.984.5337 FAX: 518.432.7454
Website: www.marktechopto.com
Email: info@marktechopto.com



Application Information

[Typical Application Circuit]

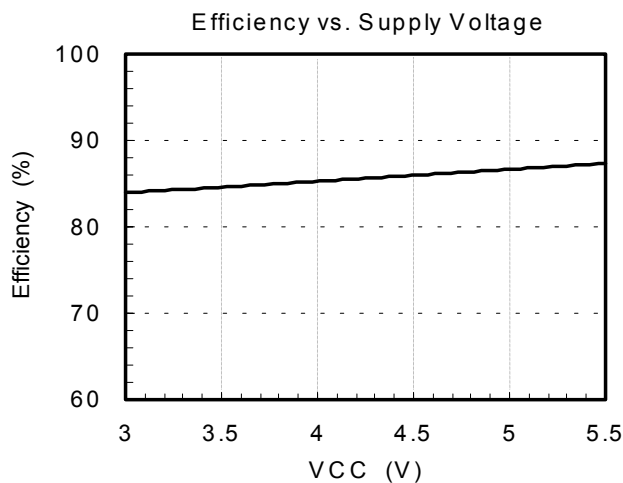
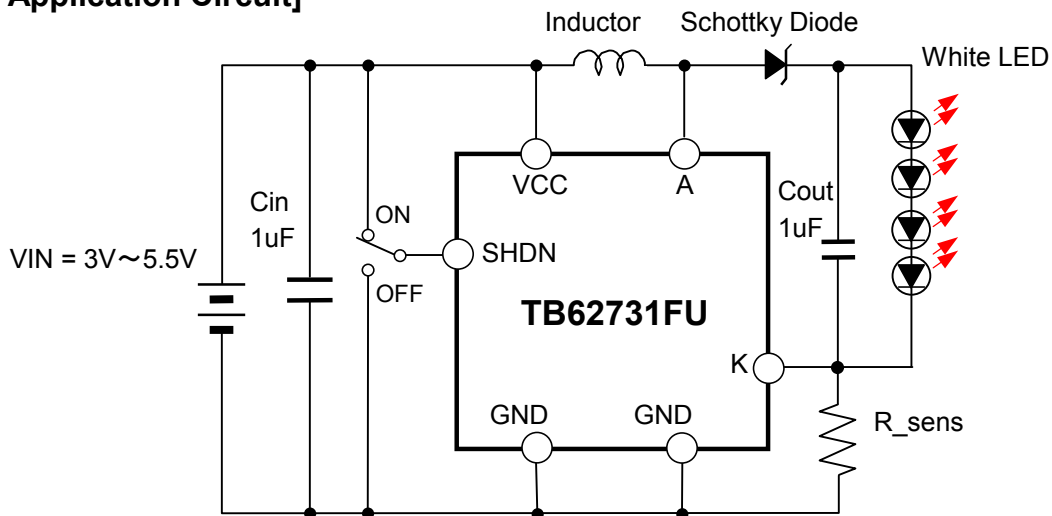

Efficiency data are taken under the following conditions;

Loads	four white LED lamps
Inductor	47uH
Schottky Diode	Vf=0.35V@0.7A

Io(K)=20mA (R_sens=1.8 ohm), Ta; 25 °C

Available from:

Marktech Optoelectronics
 120 Broadway • Menands, NY 12203
 800.984.5337 FAX: 518.432.7454
 Website: www.marktechopto.com
 Email: info@marktechopto.com



[Important Notice]

In a Typical Application Circuit, the total Vf of LED lamps must be kept larger than VCC. As the external inductor, Schottky diode, LED lamps and R_sens are connected in a series, if the total Vf is below VCC, very high currents are likely to surge into the LED lamps.

[Setting LED Driving Current]

TB62731FU is a constant output current DC/DC converter. R_sens sets the average LED driving current. (See LED driving current, Total Vf vs. Feedback resistor in this section). Also maximum supply power is limited by the following equation:

$$I_o(K) \times \text{Total Vf(max)} \leq 320\text{mW}$$

Where I_o(K) is the average LED current. Therefore, 20mA driving current can be supplied for LEDs with the total Vf(max) of 16V and this current is given by R_sens of 1.8ohm. Note that I_o(K) x Total Vf(max) over 320mW makes output voltage smaller than Total Vf(max) and turns the LED lamps off.

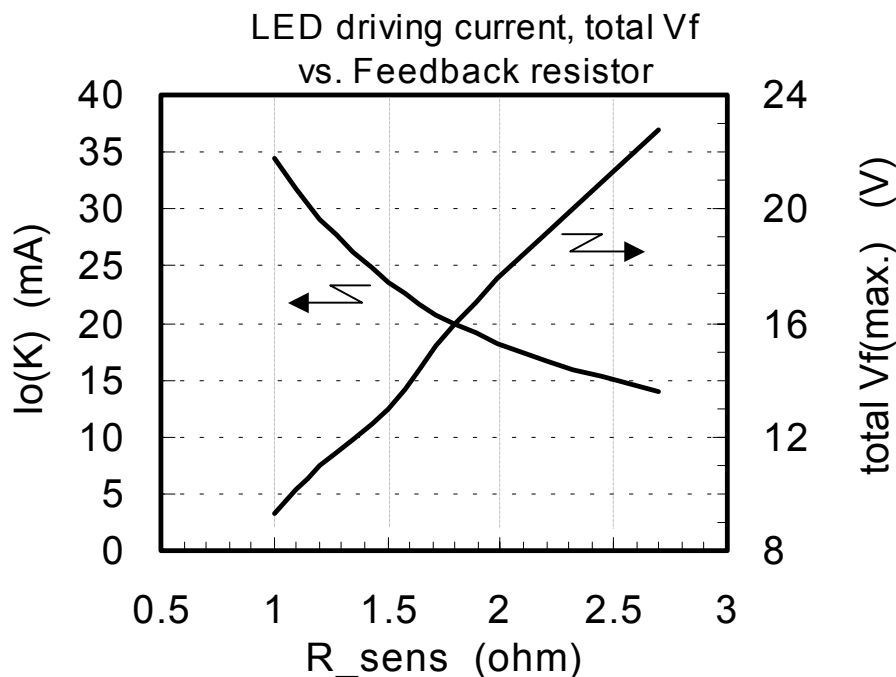

[Output Capacitor Selection]

The LED current ripple level deeply depends on the output buffering capacitor value. Larger values help to reduce output ripple and noise. TB62731FU, however, monitors the average voltage at R_sens, therefore low ripple driving current, like a DC current, is not necessarily needed. The capacitor value is not critical as viewed from LED current controlability. The output capacitance value will be decided by peak level of LED current and noise.

Available from:

Marktech Optoelectronics
 120 Broadway • Menands, NY 12203
 800.984.5337 FAX: 518.432.7454
 Website: www.marktechopto.com
 Email: info@marktechopto.com



[Inductor Selection]

A recommended inductance value is 47uH, however, values from 33uH to 56uH can also be acceptable. Low DC resistance inductors are preferable for minimizing power losses.

[PCB Pattern Layout]

When designing PCB patterns, minimize trace lengths to the inductor, pin A, Schottky diode and buffering capacitors. Also, as for feedback traces, keep them short and away from noisy traces, like an inductor's trace. Both buffering capacitors should be placed as close to the IC as possible.

Package Dimension

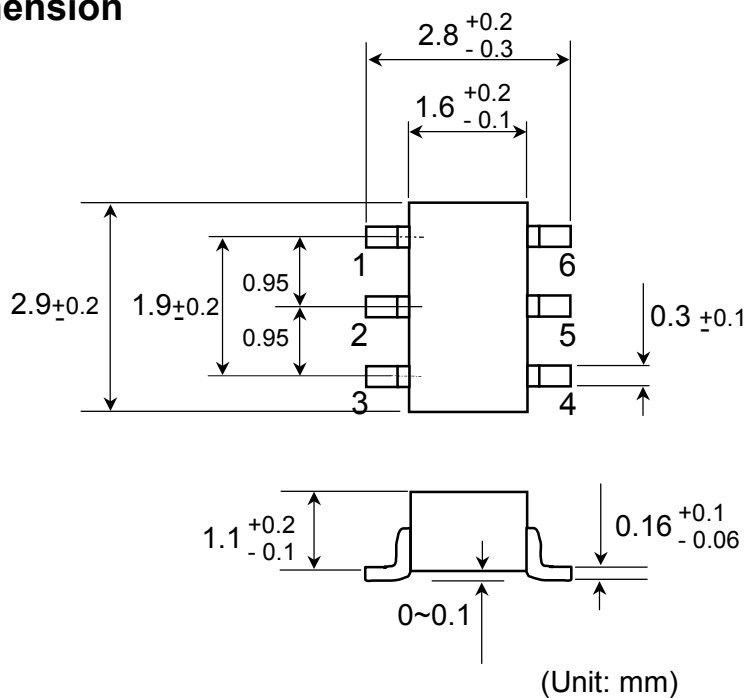

Marking

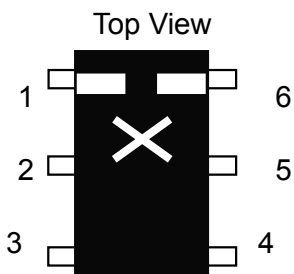

Available from:
Marktech Optoelectronics
120 Broadway • Menands, NY 12203
800.984.5337 FAX: 518.432.7454
Website: www.marktechopto.com
Email: info@marktechopto.com

