

**TOSHIBA**

**TB6520P**

TOSHIBA Bi-CMOS INTEGRATED CIRCUIT SILICON MONOLITHIC

# T B 6 5 2 0 P

## PWM TYPE 3-PHASE FULL-WAVE SENSORLESS MOTOR CONTROLLER

The TB6520P is a PWM chopper type 3-phase full-wave sensorless motor controller. It is capable of PWM type sensorless driving when used in conjunction with TA8483CP.

### FEATURES

- Three-phase sensorless driving type
- PWM chopper driving type
- PWM driving duty is controlled by analog input (built-in 7 bit A-D converter)
- Three-state output as a switch-on signal
- Built-in function for rotation frequency detection output
- Built-in lead angle control function (15 degrees)
- Built-in one-phase excitation function to improve start property
- One-phase / three-phase input mode switching function

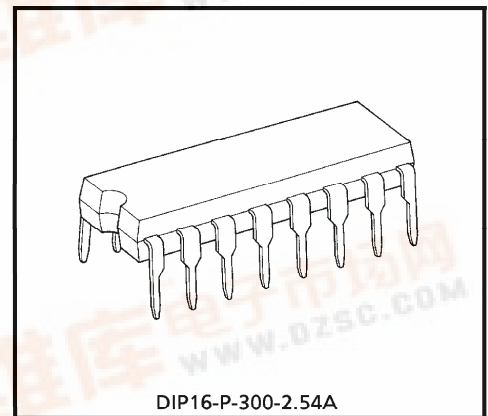

DIP16-P-300-2.54A

Weight : 1.11 g (Typ.)

980910EBA1

- TOSHIBA is continually working to improve the quality and the reliability of its products. Nevertheless, semiconductor devices in general can malfunction or fail due to their inherent electrical sensitivity and vulnerability to physical stress. It is the responsibility of the buyer, when utilizing TOSHIBA products, to observe standards of safety, and to avoid situations in which a malfunction or failure of a TOSHIBA product could cause loss of human life, bodily injury or damage to property. In developing your designs, please ensure that TOSHIBA products are used within specified operating ranges as set forth in the most recent products specifications. Also, please keep in mind the precautions and conditions set forth in the TOSHIBA Semiconductor Reliability Handbook.
- The products described in this document are subject to the foreign exchange and foreign trade laws.
- The information contained herein is presented only as a guide for the applications of our products. No responsibility is assumed by TOSHIBA CORPORATION for any infringements of intellectual property or other rights of the third parties which may result from its use. No license is granted by implication or otherwise under any intellectual property or other rights of TOSHIBA CORPORATION or others.
- The information contained herein is subject to change without notice.

**BLOCK DIAGRAM**

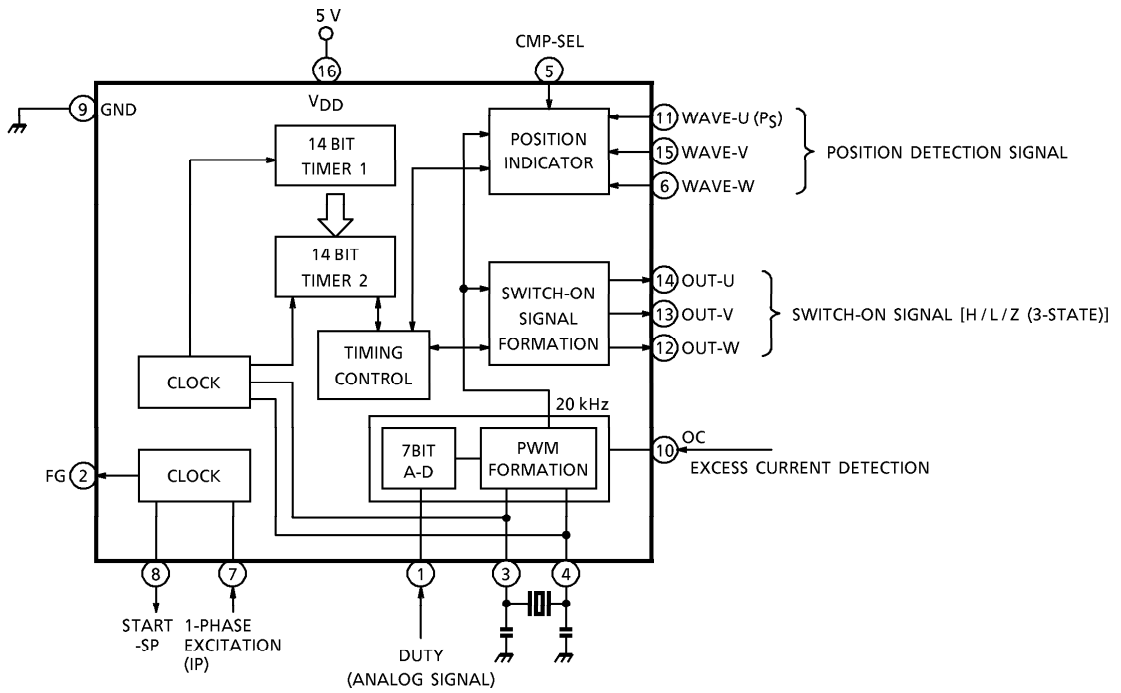

**PIN CONNECTION**

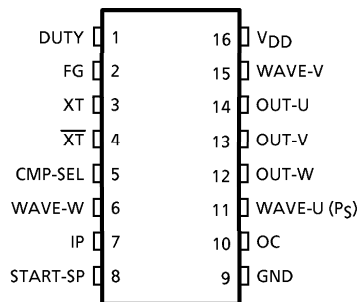

## PIN FUNCTION

PIN No.	SYMBOL	I/O	FUNCTIONAL DESCRIPTION
1	DUTY	I	Analog input pin to control PWM duty <ul style="list-style-type: none"> <li>• <math>V_{DUTY} \leq V_{AD(L)}</math> ..... Duty 0%</li> <li>• <math>V_{AD(L)} &lt; V_{DUTY} &lt; V_{AD(H)}</math> Duty change by <math>V_{DUTY}</math> (1/128 to 127/128)</li> <li>• <math>V_{DUTY} \geq V_{AD(H)}</math> ..... Duty 100% (127/128)</li> </ul> (Note) Duty becomes 100% when duty pin is open.
2	FG	O	Rotational frequency detection output <ul style="list-style-type: none"> <li>• When stopped : LOW</li> <li>• When start is forcibly transferred: LOW</li> <li>• When normally rotated : 1-pulse signal is output in one electric cycle.                4-polar motor .. 2 pulses/rotation                8-polar motor .. 4 pulses/rotation</li> </ul>
3 4	XT, $\overline{XT}$	I	Crystal oscillation pin Start transfer frequency $f_{st}$ , maximum transfer frequency $f_{mx}$ , and PWM frequency $f_p$ are determined by outer oscillator frequency. <ul style="list-style-type: none"> <li>• <math>f_{st} = f_x / 2^{18}</math></li> <li>• <math>f_{mx} = f_x / 2^{10}</math></li> <li>• <math>f_p = f_x / 256</math></li> </ul>
5	CMP-SEL	I	Position detection signal 1-phase input mode/3-phase input mode switching pin <ul style="list-style-type: none"> <li>• HIGH or OPEN: 3-phase input mode</li> <li>• LOW: 1-phase input mode</li> </ul> Pull-up resistor is built in
6	WAVE-W	I	W-phase position detection signal input. Used by 3-phase input mode. Pull-down resistor is built in.
7	IP	I	Start position determination input <ul style="list-style-type: none"> <li>• HIGH: Internal timer stopped</li> <li>• LOW: Internal timer started</li> </ul> Non-transfer operation when $V_{DUTY} > V_{AD(L)}$ , IP = HIGH (1-phase excitation) Normal operation when $V_{DUTY} > V_{AD(L)}$ , IP = LOW
8	START-SP	O	START, STOP detection output <ul style="list-style-type: none"> <li>• LOW: output on</li> <li>• HIGH: output off</li> </ul>
9	GND		Ground
10	OC	I	<ul style="list-style-type: none"> <li>• Excess current detection signal input</li> <li>• When OC = "HIGH", turn off the HIGH output of the switch-on signal.</li> <li>• Pull-down resistor is built in.</li> </ul>
11	WAVE-U	I	<ul style="list-style-type: none"> <li>• At the time of 3-phase input mode: U-phase position detection signal.</li> <li>• At the time of 1-phase input mode: position detection signal.</li> <li>• Pull-down resistor is built in.</li> </ul>
12	OUT-W	O	W-phase switch-on signal, 3-state output.
13	OUT-V	O	V-phase switch-on signal, 3-state output.
14	OUT-U	O	U-phase switch-on signal, 3-state output.
15	WAVE-V	I	V-phase position signal input. Used in 3-phase input mode. Pull-down resistor is built in.
16	V <sub>DD</sub>		5 V supply pin

**FUNCTIONAL DESCRIPTION**

1. Crystal oscillator (XT,  $\overline{XT}$ )

The crystal oscillator is connected as shown in the following diagram:

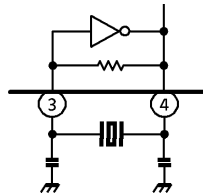

The start transfer frequency  $f_{st}$  and maximum transfer frequency  $f_{mx}$  depend upon crystal oscillation frequency  $f_x$ . Please make sure of the start operation in determining your frequency.

$$f_{st} = f_x / 2^{18}$$

$$f_{mx} = f_x / 2^{10}$$

PWM chopping frequency  $f_p$  is also determined as follows:

$$f_p = f_x / 256$$

2. Lead angle control

Operated at 0 lead angle during forced start transfer, and automatically switched to 15 lead angle upon normal transfer.

3. PWM Duty Control

PWN duty is controlled through A-D conversion of the analog voltage that is input to the DUTY pin.

- $0 (V) \leq V_{DUTY} \leq V_{AD} (L)$  DUTY 0%
- $V_{AD} (L) < V_{DUTY} < V_{AD} (H)$  (1 / 128 to 127 / 128) in the figure to the right
- $V_{AD} (H) \leq V_{DUTY} \leq V_{DD}$  DUTY 100% (127 / 128)

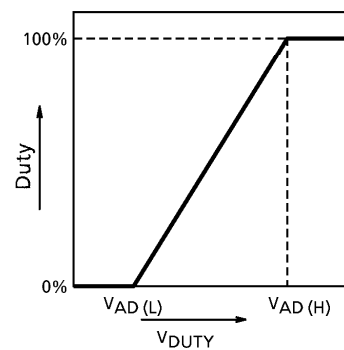

4. FG output

FG, which represents the frequency of motor rotation, is output from the position detection signal input.

- When stopped: LOW
- When start is forcibly transferred: LOW
- When normally rotated 1-pulse signal is output in one electric cycle.
  - 4-polar motor      2 pulses / rotation
  - 8-polar motor      4 pulses / rotation

## MAXIMUM RATING

CHARACTERISTICS	SYMBOL	RATING	UNIT
Supply Voltage	$V_{DD}$	7	V
Input Voltage	$V_{IN}$	$V_{DD}$	V
Power Dissipation	$P_D$	300	mW
Operating Temperature	$T_{opr}$	-30~85	°C
Storage Temperature	$T_{stg}$	-55~150	°C

RECOMMENDED OPERATING CONDITIONS ( $T_a = -30$  to  $85^\circ\text{C}$ )

CHARACTERISTICS	SYMBOL	TEST CONDITION	MIN	TYP.	MAX	UNIT
Supply Voltage	$V_{DD}$	—	4.5	5.0	5.5	V
Input Voltage	$V_{IN}$	—	GND	—	$V_{DD}$	V
OSC Frequency	$f_{osc}$	—	1.0	—	10	MHz

ELECTRICAL CHARACTERISTICS ( $T_a = 25^\circ\text{C}$ ,  $V_{DD} = 5\text{V}$ )

CHARACTERISTICS	SYMBOL	TEST CIRCUIT	TEST CONDITION	MIN	TYP.	MAX	UNIT
Rest Supply Current	$I_{DD}$	1	DUTY = 0 V	—	2	5	mA
Operating Supply Current	$I_{DD (opr)}$	2	DUTY = 5 V	—	2	5	mA
Input Current	$I_{IN-1 (H)}$	3	$V_{IN} = 5\text{V}$ , WAVE-U, WAVE-V WAVE-W, OC	—	50	—	$\mu\text{A}$
	$I_{IN-1 (L)}$	4	$V_{IN} = 0\text{V}$ , WAVE-U, WAVE-V WAVE-W, OC	-1	0	—	
	$I_{IN-2 (H)}$	3	$V_{IN} = 5\text{V}$ , IP	—	0	1	
	$I_{IN-2 (L)}$	4	$V_{IN} = 0\text{V}$ , IP	-1	0	—	
	$I_{IN-3 (H)}$	3	$V_{IN} = 5\text{V}$ , CMP-SEL	—	0	1	
	$I_{IN-3 (L)}$	4	$V_{IN} = 0\text{V}$ , CMP-SEL	-75	-50	—	
	$I_{IN-4 (H)}$	3	$V_{IN} = 5\text{V}$ , DUTY	—	0	1	
Output Leakage Current	$I_L (L)$	5	$V_{DD} = 7\text{V}$ , $V_{OUT} = 7\text{V}$ OUT-U, OUT-V, OUT-W	—	0	10	$\mu\text{A}$
	$I_L (H)$	6	$V_{DD} = 7\text{V}$ , $V_{OUT} = 0\text{V}$ OUT-U, OUT-V, OUT-W	—	0	10	
Output Voltage	$V_O (H)$	7	$I_O = 200\ \mu\text{A}$ , OUT-U, OUT-V OUT-W, START-SP, FG	4.3	—	$V_{DD}$	V
	$V_O (L)$	8	$I_O = 200\ \mu\text{A}$ , OUT-U, OUT-V OUT-W, START-SP, FG	GND	—	0.5	
Input Voltage	$V_{IN (H)}$	7	WAVE-U, WAVE-V, WAVE-W OC, IP, CMP-SEL	3.5	—	5.15	V
	$V_{IN (L)}$	8	WAVE-U, WAVE-V, WAVE-W OC, IP, CMP-SEL	GND	—	1.5	
Input Hysteresis Voltage	$V_H$	—	WAVE-U, WAVE-V, WAVE-W OC, IP	—	0.6	—	V
ADC Input Voltage Range	$V_{AD (L)}$	9	DUTY	0.44	0.49	0.54	V
	$V_{AD (H)}$	9	DUTY	4.1	4.3	4.5	

TEST CIRCUIT 1:  $I_{DD}$

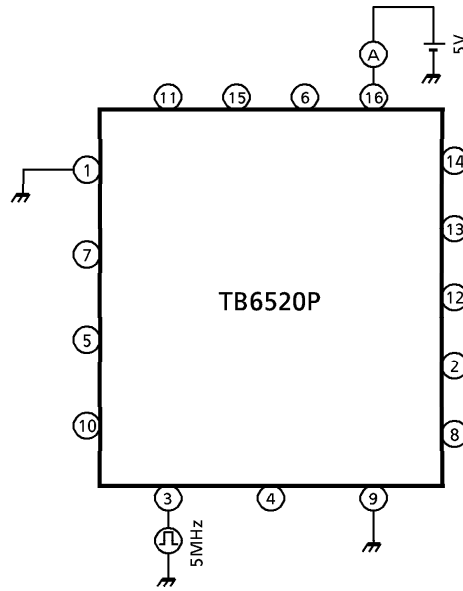

TEST CIRCUIT 2:  $I_{DD}$  (opr.)

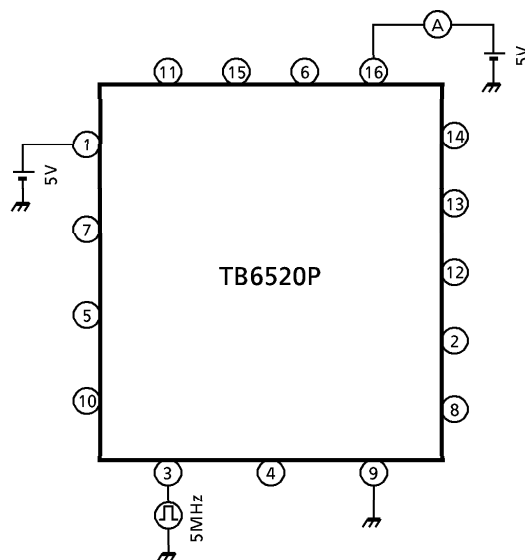

**TEST CIRCUIT 3:  $I_{IN}$  (H)**

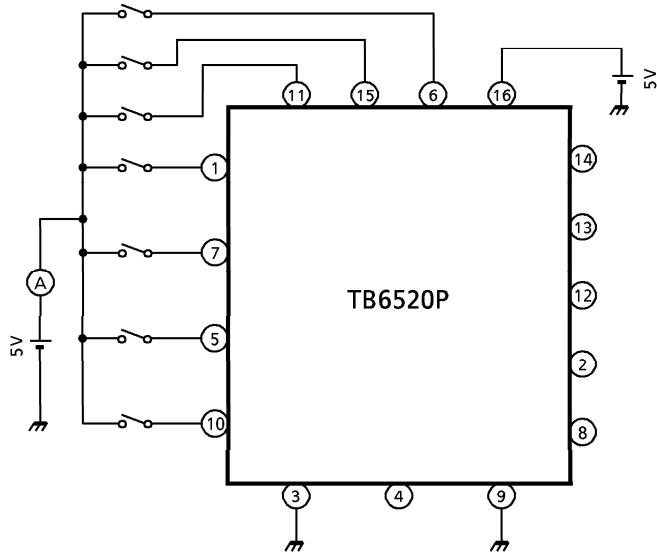

**TEST CIRCUIT 4:  $I_{IN}$  (L)**

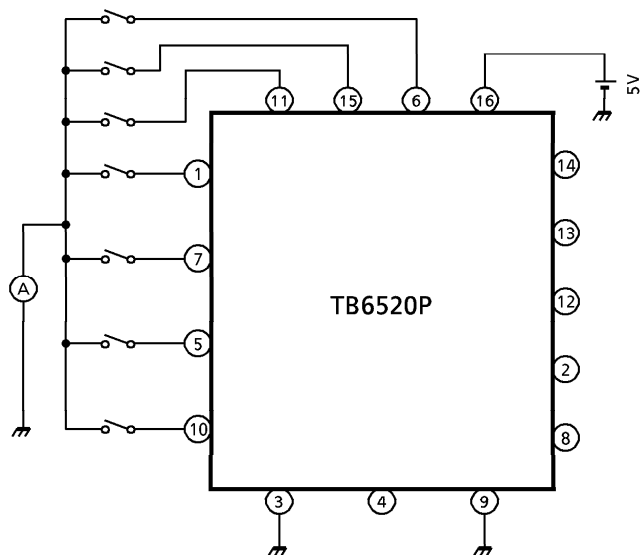

**TEST CIRCUIT 5:  $I_L(L)$**

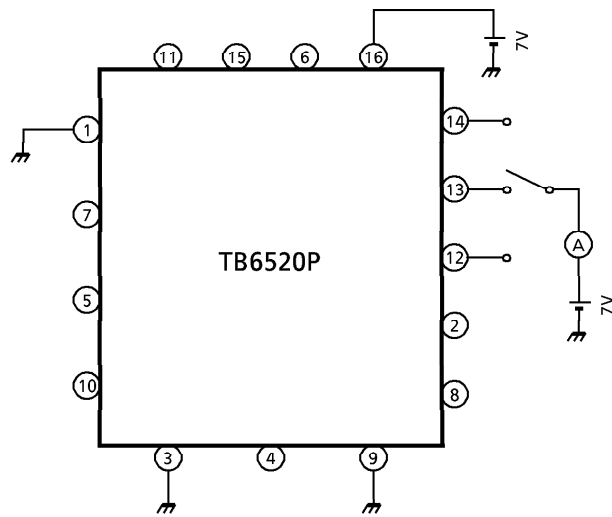

**TEST CIRCUIT 6:  $I_L(H)$**

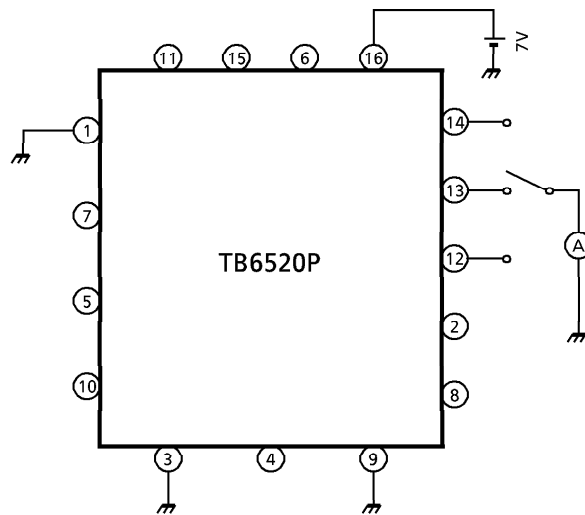



TEST CIRCUIT 7

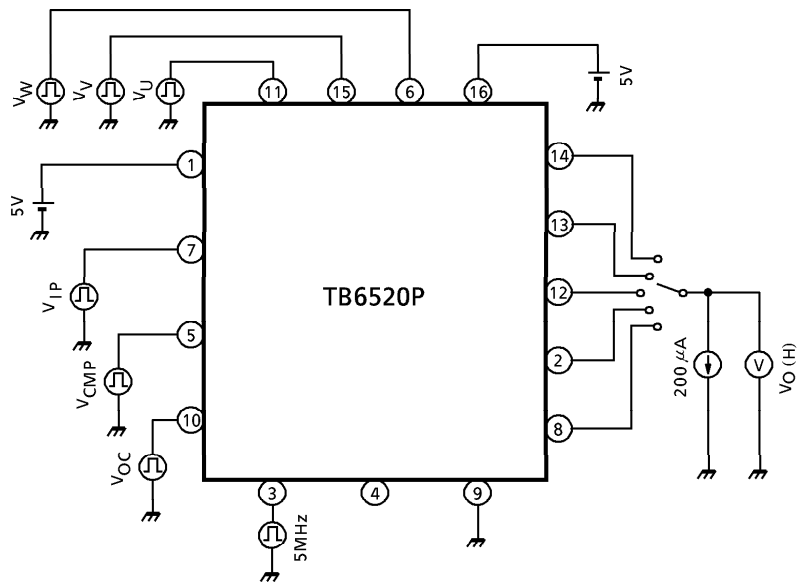

- Input amplitude 1.5 to 3.5 V to  $V_U$ ,  $V_V$ ,  $V_W$ ,  $V_{IP}$ ,  $V_{COMP}$ , and  $V_{OC}$ , and causes the output to function.

TEST CIRCUIT 8

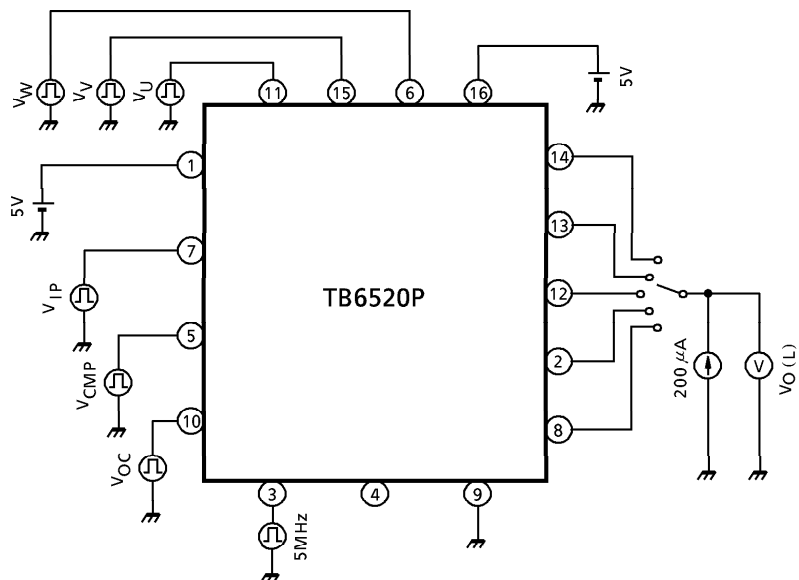

- Input amplitude 1.5 to 3.5 V to  $V_U$ ,  $V_V$ ,  $V_W$ ,  $V_{IP}$ ,  $V_{COMP}$ , and  $V_{OC}$ , and cause the output to function.

TEST CIRCUIT 9:  $V_{AD}(L)$ ,  $V_{AD}(H)$

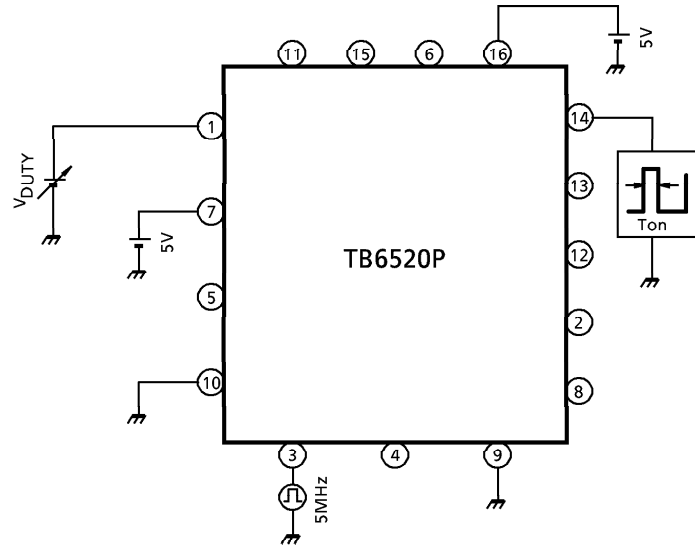

- Change  $V_{DUTY}$  and measure  $T_{on}$ .

FUNCTION DESCRIPTION OF TB6520P + TA8483CP

- Three-phase sensorless drive

The TB6520P detects the motor's induced voltage (motor's terminal voltage), compares it with VM (motor's power supply voltage) divided by 2, and generates a commutation signal based on the comparison result. Therefore, the TB6520P eliminates the need for the Hall elements and Hall ICs that have conventionally been used to detect the motor's rotor position.

- PWM drive

The TB6520P allows output duty cycles to be controlled by using its DUTY input voltage.

PWM operation is chopped by the upper-side output on/off operation.

Position detection is accomplished by monitoring the motor's terminal voltage at falling edges of PWM and comparing the detected voltage with the reference voltage. In this way, avoid effects of the terminal voltage on PWM are avoided. But this causes a position detection error associated with the PWM signal frequency. Therefore, care must be taken when using the controller for high-speed motors.

- Startup method

At startup, no induced voltage develops because the motor is not turning yet. For this reason, the TB6520P forcibly applies a predetermined commutation pattern to the motor as it starts.

In this case, a problem occurs that the motor cannot be started smoothly depending on its rotor position.

To solve this problem, the TB6520P uses single-phase excitation (by setting the IP pin high to fix the phase and allow current to conduct in only one phase) for a predetermined period. This helps to move the rotor position at startup forcibly to a ready to start position.

However, since the duration of single-phase excitation and the power applied for it (DUTY input voltage) varies with each motor, adjustment is required.

- About the duration of single-phase excitation

The duration of single-phase excitation (DC excitation) can be changed by adjusting the RC constant in the application circuit shown below.

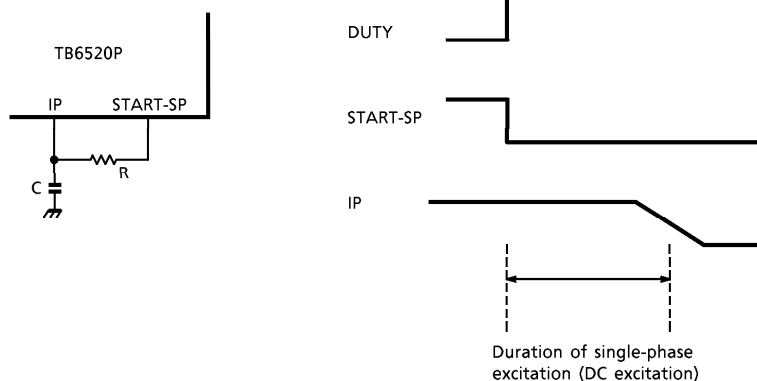

Setup example : C = 4.7  $\mu$ F、 R = 220 k $\Omega$

- Changing and stopping revolutions

(1) The motor speed or revolutions can be changed by adjusting the  $V_{DUTY}$  voltage (TB6520P input voltage).

(2) To stop the motor, drop  $V_{DUTY}$  to 0V.

- About stepping-out

Monitor the TB6520P's speed detection signal (FG output) to see if a FG signal of the designated frequency is returned. If not, the motor has stepped out of synchronization, so restart it.

- About overcurrent limiting operation

The TA8483CP's overcurrent detection function works in such a way that the motor current is detected using an external resistor and when the voltage that develops in the resistor exceeds the reference voltage  $V_{RF}$ , the ISD signal is driven high. The TB6520P limits the ON-time of the PWM signal (output by the TB6520P) at a rising edge of the ISD signal. The ON-time of the upper-side power transistor in the TA8483CP is thereby limited.

- Lead angle control

The TB6520P determines the commutation timing based on the changeover point (zero-cross point) of the induced voltage and reference voltage  $V_n$  (=  $V_M$  (motor's power supply voltage) divided by 2).

During forced starting commutation, the motor operates with a lead angle of 0 degrees. After the motor switches over to normal-speed operation, the lead angle is automatically changes to 15 degrees.

(Lead angle of 0 degrees : For 120-degree switch-on, current starts conducting 30 degrees behind the zero-cross point. Lead angle of 15 degrees : Current starts conducting 15 degrees behind the zero-cross point.)

Note that depending on motor characteristics, the waveform of the induced voltage may be distorted, causing the zero-cross point to slip out of place. The commutation timing also is thereby made to drift.

## Precautions on Using TB6520P + TA8483CP

- About DC Power voltage and control voltage on/off sequence

The power-on sequence dictates that  $V_{CC}$  (TA8483CP power supply) be turned on after  $V_{DD}$  (TB6520P power supply) becomes steadily on.

When powering on, make sure  $V_{DUTY}$  (PWM control input to the TB6520P) is dropped to 0 V.

When powering off, make sure  $V_{DUTY}$  (PWM control input to the TB6520P) is dropped to 0 V.

Before shutting off  $V_{DD}$  (TB6520P power supply voltage) wait until  $V_{CC}$  (TA8483CP power supply voltage) is sufficiently low (5 V or less).

The thing that especially requires caution is that shutting off  $V_{DD}$  during high-speed rotation or floating GND causes a short-circuit current to flow in due to counterelectromotive force, which could break down the output transistors.

When  $V_{DD}$  is shut off, the TB6520P output is pulled to GND and the TA8483CP input goes low, causing all of the lower-side output transistors to turn on. Because the motor is turning, a short-circuit current is generated by counterelectromotive force and flows into the transistors as shown below. This current, if large enough to exceed the rated current, may break the transistors. (This trouble tends to occur when the motor is not loaded.)

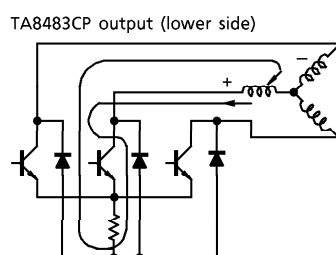

- About an external oscillator for the TB6520P

The TB6520P has an external oscillator attached as the reference clock source to generate PWM control and commutation signals. Selection of this oscillator requires caution.

Some oscillator may oscillate erratically if the power supply turn-on time is fast (1 ms or less), causing the TB6520P to malfunction. In this case, the drive IC, the TB8483CP, may break down. (This is because the TB6520P output is uncertain and the overcurrent limiting function becomes unable to work.)

- About the TB6520P DUTY input

When the DUTY pin is open, the duty cycle is full (100%).

If the motor with the TA8483CP connected to it is made to run without turning on the power supply voltage, the induced voltage in the motor wraps around into the TB6520P, causing it to malfunction, which in turn may break down the TA8483CP.

Make sure the DUTY pin is pulled low via a resistor (approx. 100 k $\Omega$ ).

- About external diode

For reason of PWM control, when PWM turns off, a regenerative current flows in the lower-side diodes at the output stage.

Always be sure to attach an external diode. This external diode must have a sufficient current capacity to satisfy the maximum value of the motor current. Another thing to be noted is that a through current flows depending on the diode's reverse recovery time.

Toshiba recommends attaching a Schottky diode (2GWJ42 or equivalent).

- Other precautions to be observed

(1) When  $V_{DD}$  changes slowly (1 V/s or less) between 2 to 4 V (near 3.8 V), the TA8483CP's output transistors are placed in an oscillating state and could thereby be broken.

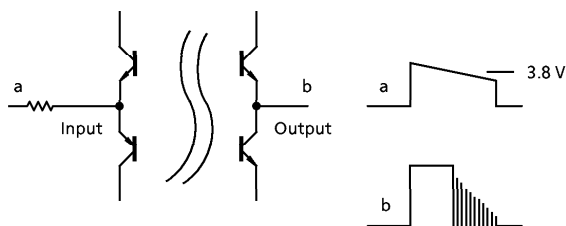

(2) If  $V_{CC}$  and  $V_{DD}$  are connected to the GND line that is floating, the device may break down.

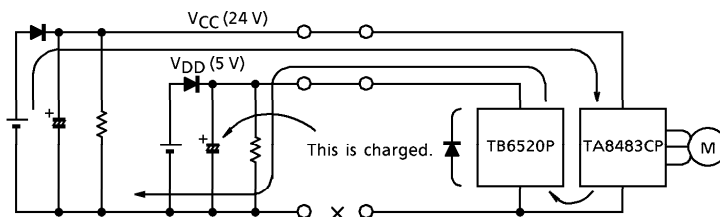

When the GND line goes open, the capacitor on the low-voltage power supply side is charged with a high voltage from the 24 V line through a circuit shown above. When GND is connected next time, the device may be broken by that voltage.

APPLICATION CIRCUIT (1-PHASE INPUT MODE)

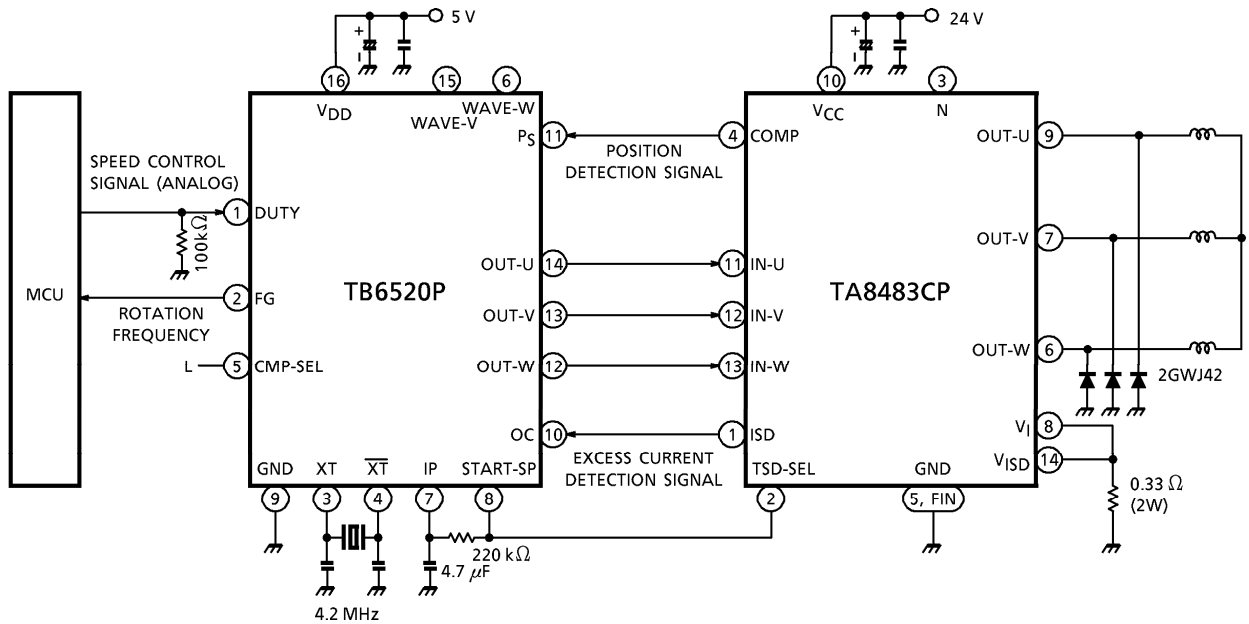

OUTLINE DRAWING  
DIP16-P-300-2.54A

Unit : mm

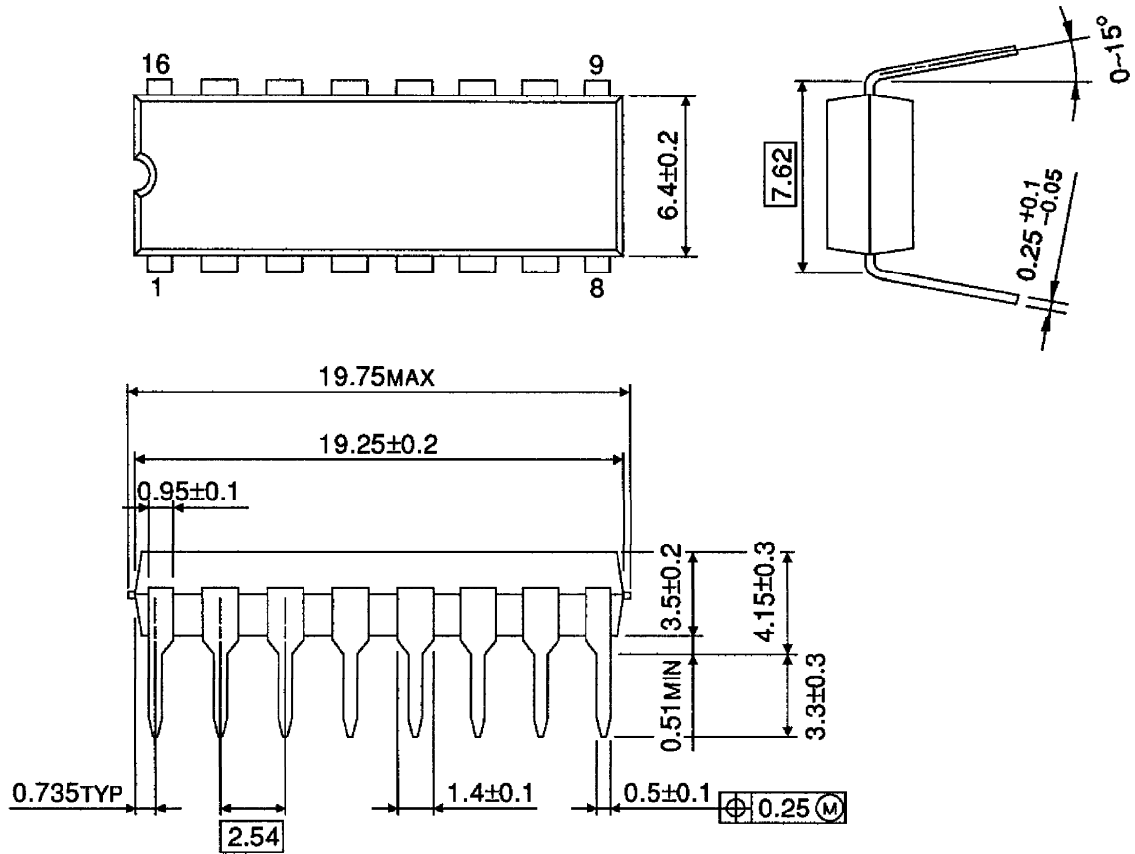

Weight : 1.11 g (Typ.)