

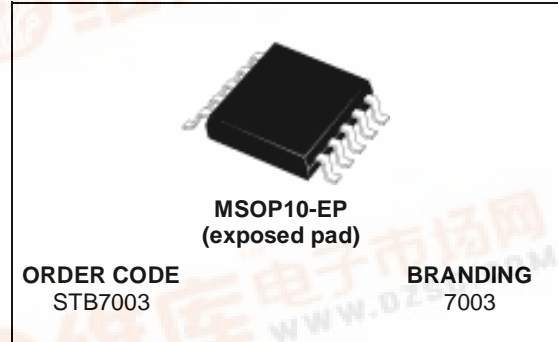

STB7003

TRI-BAND GSM/DCS/PCS LNA

- SUPPLY VOLTAGE 2.8V
- LOW CURRENT CONSUMPTION
- VERY LOW NOISE FIGURE:
 - NF=1.5dB @ 950MHz
 - NF=1.9dB @ 1850MHz
 - NF=2dB @ 1950MHz
- DIGITAL GAIN CONTROL



APPLICATIONS

TRI-BAND GSM/DCS/PCS FRONT-ENDS

DESCRIPTION

The STB7003 is a tri-band LNA designed for GSM/DCS/PCS applications. The GC pin sets the LNA gain levels. The innovative architecture implemented allows to reach very low current consumption. LNA1 works at 0.9-1.0 GHz and LNA2 over the 1.8-2GHz frequency range.

FUNCTIONAL BLOCK DIAGRAM

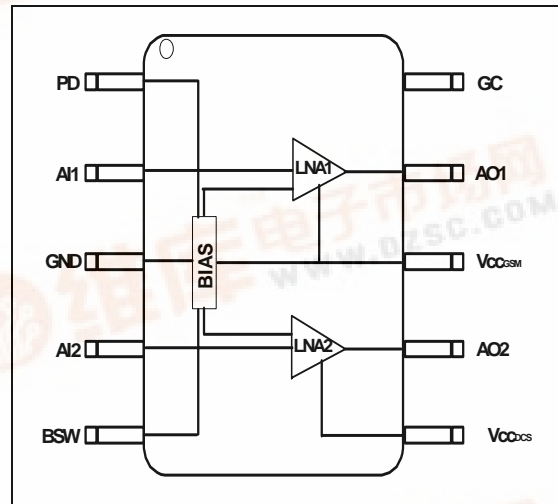

ABSOLUTE MAXIMUM RATING

Symbol	Parameter	Value	Unit
Vcc	Supply voltage	4.5	V
Tj	Junction temperature	150	°C
Tstg	Storage temperature	-40 to +85	°C

THERMAL DATA

Symbol	Parameter	Value	Unit
R _{th(j-a)}	Thermal resistance junction-ambient	TBD	°C/W

STB7003

ELECTRICAL CHARACTERISTICS (V_{cc} = 2.8V, T_{amb} = 25 °C)

Symbol	Parameter	Test conditions	Min.	Typ.	Max.	Unit
V _{cc}	Supply voltage		2.7		3.3	V
I _{PD}	Sleep supply current				5	uA

LNA1 @ 950MHz

I _{cc}	Supply current			4.5		mA
G	Power gain	G _{p1} ⁽¹⁾ G _{p2} ⁽¹⁾		-1 16		dB
NF	Noise figure	G _{p1} G _{p2}		5.5 1.5		dB
P1dB	Input 1 dB compr. power	G _{p1} G _{p2}		-19 -21		dBm
IIP3	Input third order intercept	G _{p1} ⁽²⁾ G _{p2} ⁽²⁾		-10.8 -12.6		dBm
VSWR _i	Input VSWR			2:1		
VSWR _o	Output VSWR			2:1		

LNA2 @ 1850MHz

I _{cc}	Supply current			7.3		mA
G	Power gain	G _{p1} ⁽¹⁾ G _{p2} ⁽¹⁾		-4 14.7		dB
NF	Noise figure	G _{p1} G _{p2}		9.6 1.9		dB
P1dB	Input 1 dB compr. power	G _{p1} G _{p2}		-11.5 -13.1		dBm
IIP3	Input third order intercept	G _{p1} ⁽³⁾ G _{p2} ⁽³⁾		-1.4 -3.5		dBm
VSWR _i	Input VSWR			2:1		
VSWR _o	Output VSWR			2:1		

LNA2 @ 1950MHz

I _{cc}	Supply current			7.3		mA
G	Power gain	G _{p1} ⁽¹⁾ G _{p2} ⁽¹⁾		-4.5 14.7		dB
NF	Noise figure	G _{p1} G _{p2}		9.8 2		dB
P1dB	Input 1 dB compr. power	G _{p1} G _{p2}		-10.8 -12.6		dBm
IIP3	Input third order intercept	G _{p1} ⁽⁴⁾ G _{p2} ⁽⁴⁾		-1.5 -3.7		dBm
VSWR _i	Input VSWR			2:1		
VSWR _o	Output VSWR			2:1		

Note(1) : G_{p1} min gain, G_{p2} max gain.

Note(2) : Measured data with two tones f_{IN1} = 945 MHz, f_{IN2} = 945.8 MHz, P_{IN} = - 33 dBm for each tone

Note(3) : Measured data with two tones f_{IN1} = 1850 MHz, f_{IN2} = 1850.8 MHz, P_{IN} = - 33 dBm for each tone

Note(4) : Measured data with two tones f_{IN1} = 1960 MHz, f_{IN2} = 1960.8 MHz, P_{IN} = - 33 dBm for each tone

GAIN SELECTION

BSW	GC	GSM LNA1	DCS/PCS LNA2
0	0	High gain	Off
0	1	Low gain	Off
1	0	Off	High gain
1	1	Off	Low gain

PINOUT

Pin Number	Symbol	Description
1	PD	Power down
2	AI1	GSM LNA1 input
3	GND	Ground
4	AI2	DCS/PCS LNA2 input
5	BSW	Band switch between GSM and DCS/PCS RF output
6	V _{CCDCS}	DCS Supply voltage
7	AO2	DCS/PCS LNA2 output
8	V _{CCGSM}	GSM/BIAS Supply voltage
9	AO1	GSM LNA1 output
10	GC	LNA1/2 gain control

STB7003

TYPICAL PERFORMANCE (GSM BAND)

Power Gain vs. Frequency

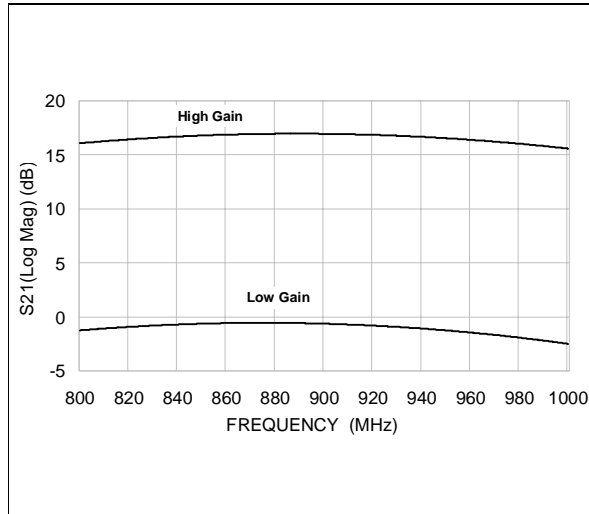

Noise Figure vs. Frequency

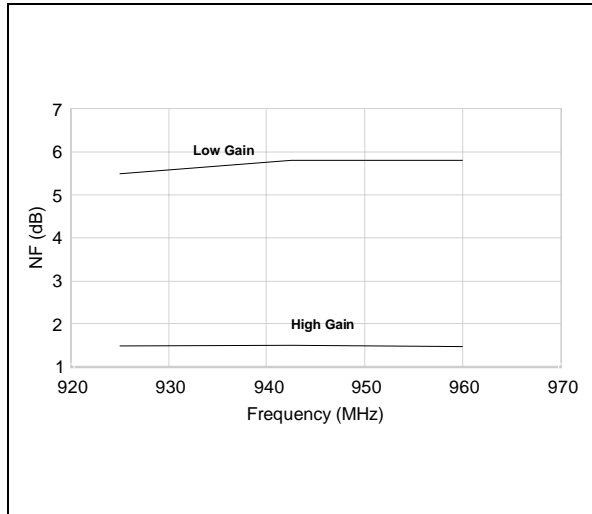

Input Return Loss vs. Frequency

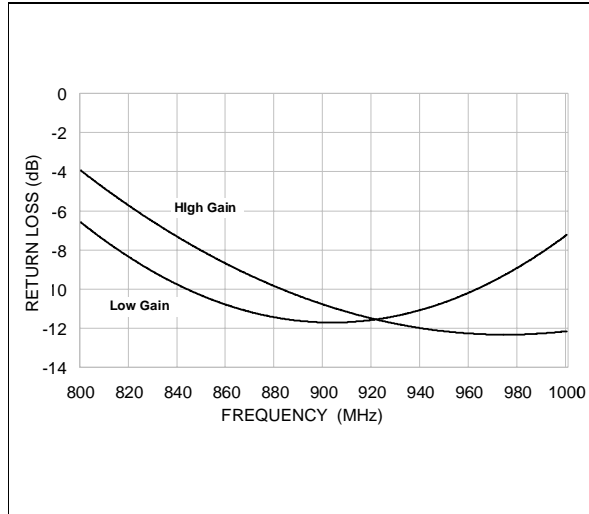

Output Return Loss vs. Frequency

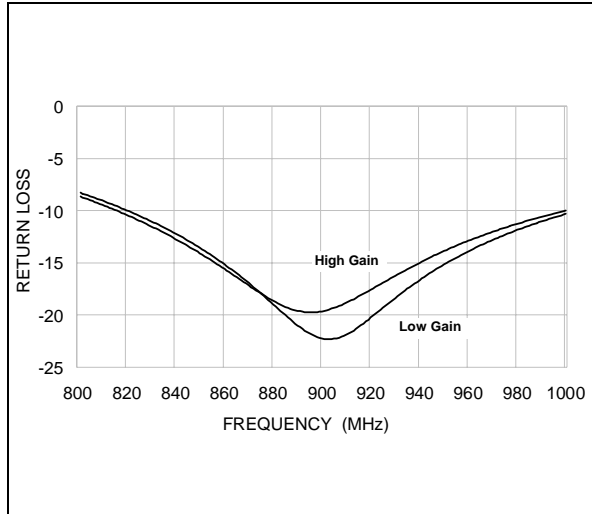

Reverse Isolation vs. Frequency

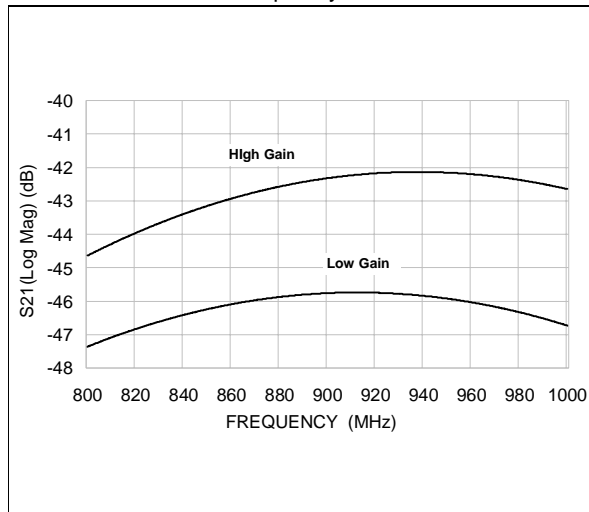

TYPICAL PERFORMANCE (DCS / PCS BAND)

Power Gain vs. Frequency

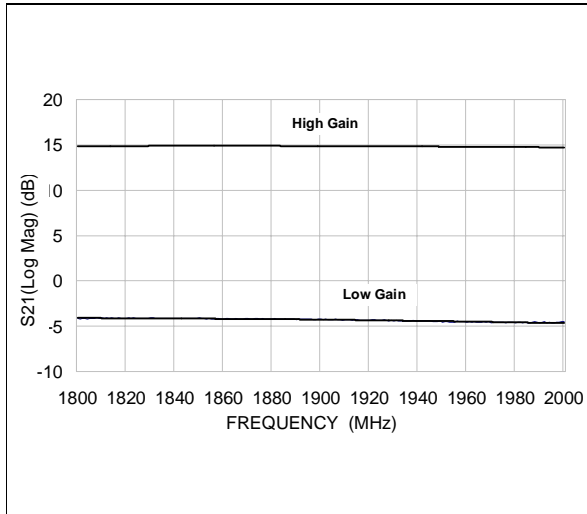

Noise Figure vs. Frequency

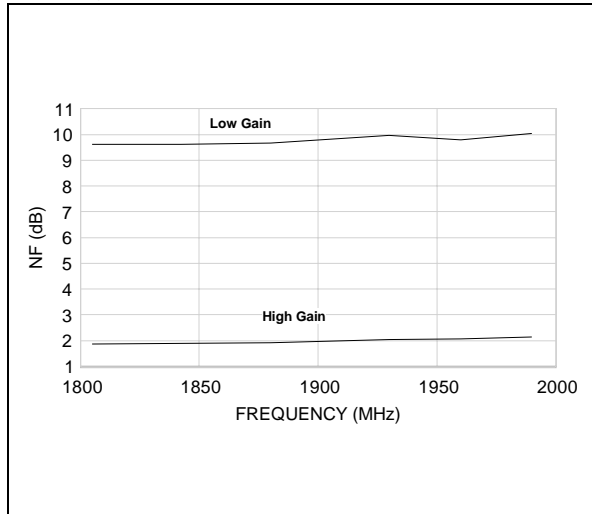

Input Return Loss vs. Frequency

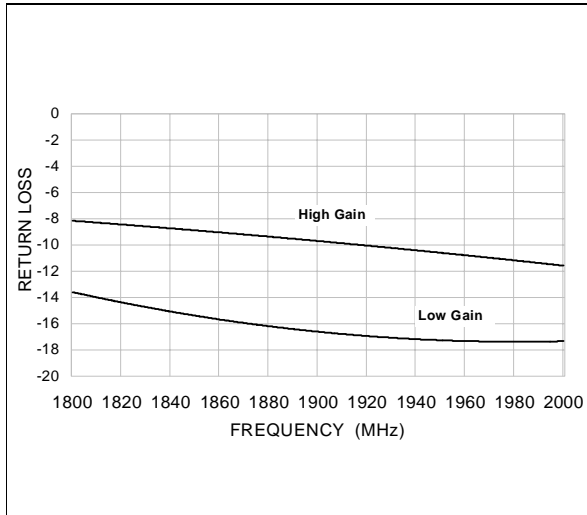

Output Return Loss vs. Frequency

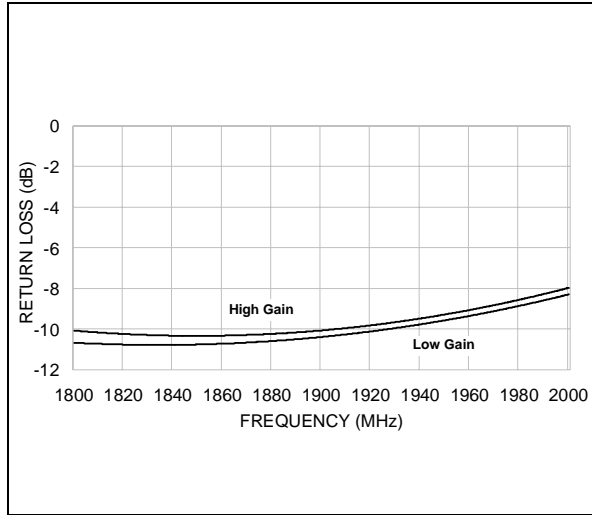

Reverse Isolation vs. Frequency

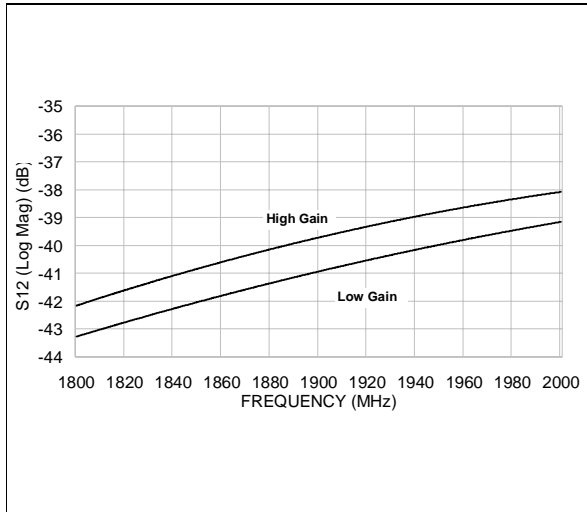

STB7003

TEST CIRCUIT SCHEMATIC

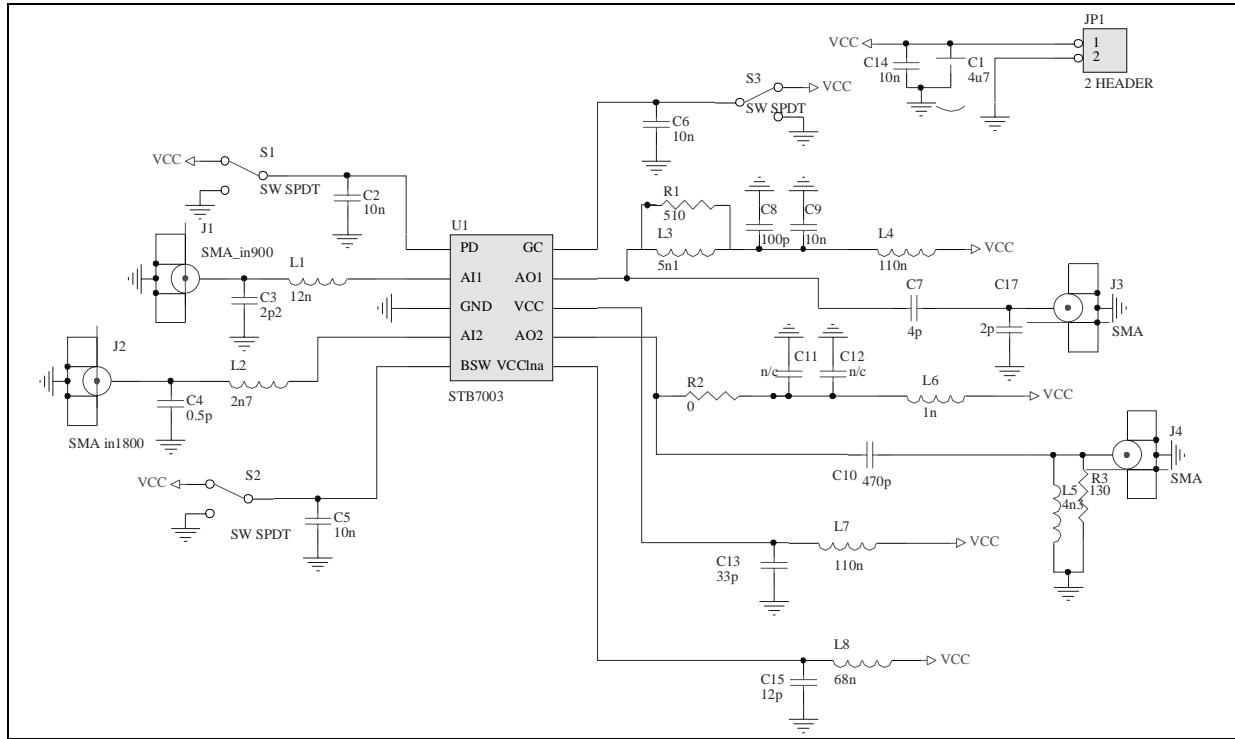

BILL OF MATERIAL

Used	Part Type	Designator	Footprint	Description
1	12n	L1	0603	COILCRAFT KIT C124-2
1	2n7	L2	0603	COILCRAFT KIT C124-2
1	5n1	L3	0603	COILCRAFT KIT C124-2
2	110n	L4, L7	0603	COILCRAFT KIT C124-2
1	4n3	L5	0603	COILCRAFT KIT C124-2
1	1n	L6	0402	COILCRAFT KIT C128
1	68n	L8	0603	COILCRAFT KIT C124-2
1	1u	C1	TAG A	
6	10n	C2, C5, C6	0603	MURATA 0603 KIT
		C9, C14		
1	2p2	C3	0603	MURATA 0603 KIT
1	0.5p	C4	0603	MURATA 0603 KIT
1	4p	C7	0603	MURATA 0603 KIT
1	100p	C8	0603	MURATA 0603 KIT
1	470p	C10	0603	MURATA 0603 KIT
2	n/c	C11, C12	0603	
1	33p	C13	0603	MURATA 0603 KIT
1	12p	C15	0603	MURATA 0603 KIT
1	2p	C17	0603	MURATA 0603 KIT
1	510	R1	0603	
1	0	R2	0603	
1	130	R3	0603	

EVALUATION BOARD

TOP LAYER

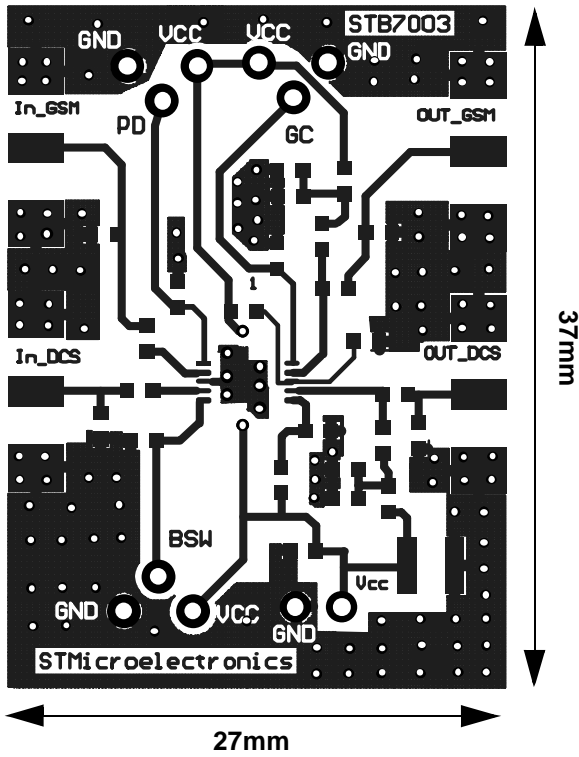

COMPONENTS PLACEMENT

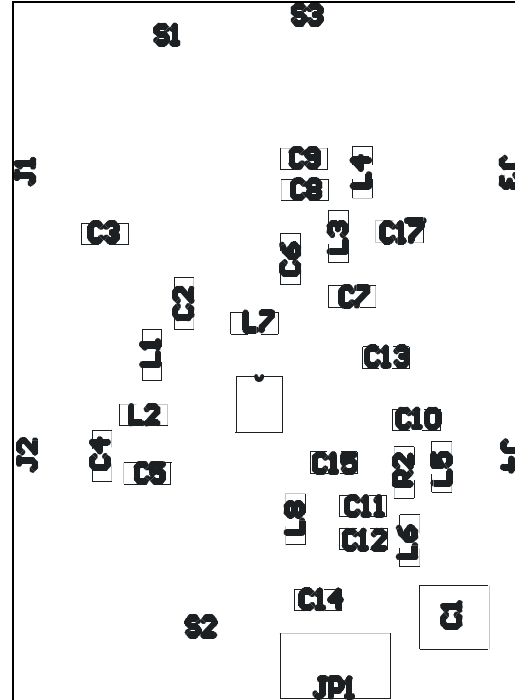

PCB CROSS SECTION

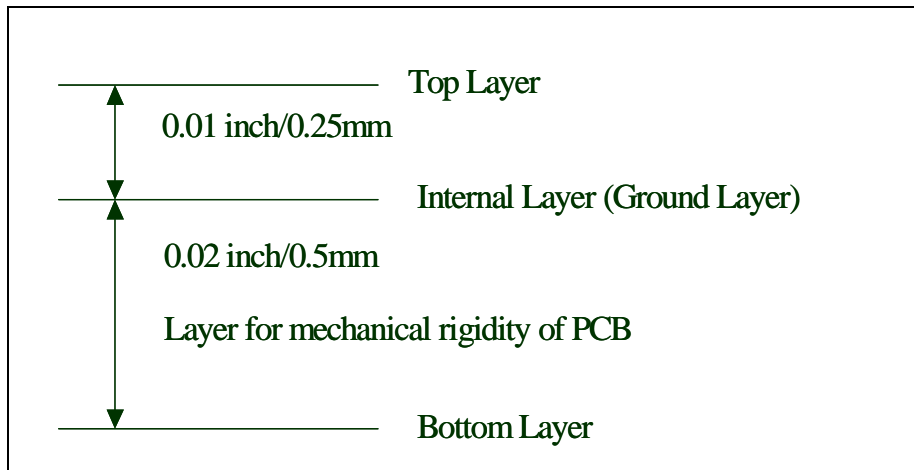

STB7003

MECHANICAL DATA

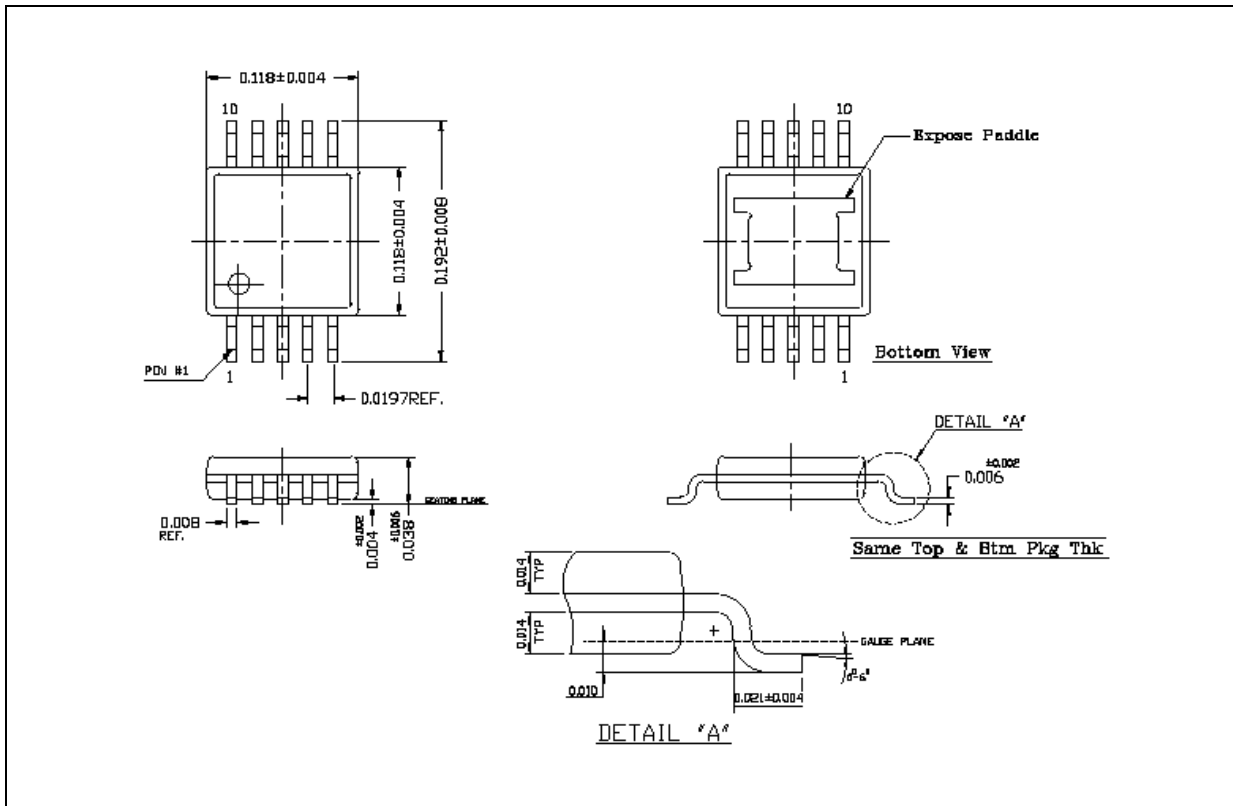

Information furnished is believed to be accurate and reliable. However, STMicroelectronics assumes no responsibility for the consequences of use of such information nor for any infringement of patents or other rights of third parties which may result from its use. No license is granted by implication or otherwise under any patent or patent rights of STMicroelectronics. Specifications mentioned in this publication are subject to change without notice. This publication supersedes and replaces all information previously supplied. STMicroelectronics products are not authorized for use as critical components in life support devices or systems without express written approval of STMicroelectronics.

The ST logo is registered trademark of STMicroelectronics
© 2002 STMicroelectronics - All Rights Reserved

All other names are the property of their respective owners.

STMicroelectronics GROUP OF COMPANIES
Australia - Brazil - Canada - China - Finland - France - Germany - Hong Kong - India - Israel - Italy - Japan -
Malaysia - Malta - Morocco - Singapore - Spain - Sweden - Switzerland - United Kingdom - U.S.A.
<http://www.st.com>