



查询TC04A-200供应商

SEMTECH

捷多邦, 专业PCB打样工厂, 24小时加急出货

TC04A-200

Battery Tracking TransClamp™ For SLIC Linecard Protection

PROTECTION PRODUCTS

Description

The battery tracking TransClamp series of transient voltage suppressors (TVS) are designed to protect subscriber line interface circuit (SLIC) from transient voltages resulting from lightning strikes and AC power line disturbances. The TC04A-200 integrates all the components necessary to protect SLIC ICs from line to ground for positive and negative transients.

For negative transient events, the TVS thyristor will crowbar or “fire” when the line voltage exceeds the gate reference voltage. The gate voltage is referenced to the battery voltage ($-V_{BAT}$) plus the V_F of the series rectifier. The device firing voltage range is -5V to -100V. For positive transients, the surge-rated rectifiers will be forward biased, shunting the current to ground. An external capacitor is used to aid in gate triggering during fast rise time transients.

The device may be used to protect any SLIC including those with integrated ring generators.

These devices are designed to meet industry standard transient immunity requirements such as Bellcore TR-NWT-001089, FCC Part 68, ITU K17-K20, and IEC 61000-4-5. The integrated design saves board space and increases equipment reliability by replacing multiple discrete components.

Features

- ◆ Transient protection for telecommunications lines to **Bellcore 1089 (long haul), VDE 0433, ITU K20 IEC 61000-4-5 (Lightning), and FCC Part 68**
- ◆ High surge current rating (100A, $t_p = 10/1000\mu s$)
- ◆ Protects up to four Tip & Ring line pairs
- ◆ Gate firing voltage is referenced to the system battery voltage
- ◆ Wide firing voltage range: -5V to -100V
- ◆ High holding current: 200mA
- ◆ Replaces multiple discrete components
- ◆ Solid-state TVS process technology

Mechanical Characteristics

- ◆ JEDEC SO-16 WB package
- ◆ Molding compound flammability rating: UL 94V-0
- ◆ Marking : Part number, date code, logo
- ◆ Packaging : Tube or Tape and Reel per EIA 481

Applications

- ◆ Subscriber Line Interface Circuit (SLIC) Protection
- ◆ Central Office Equipment
- ◆ ISDN Terminal Adaptors
- ◆ Cable Telephony
- ◆ Small Office Home Office (SOHO) Applications
- ◆ Wireless Local Loop (WLL)
- ◆ Fibre In The Loop (FITL)

Circuit Diagram (Each Line)

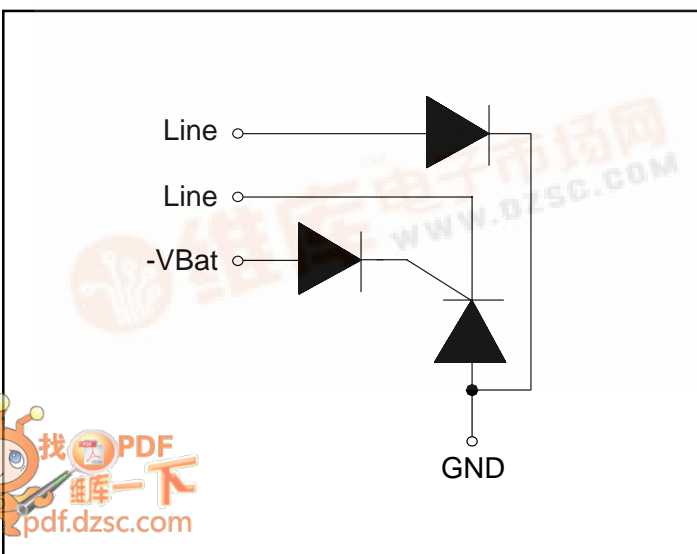

Schematic & PIN Configuration

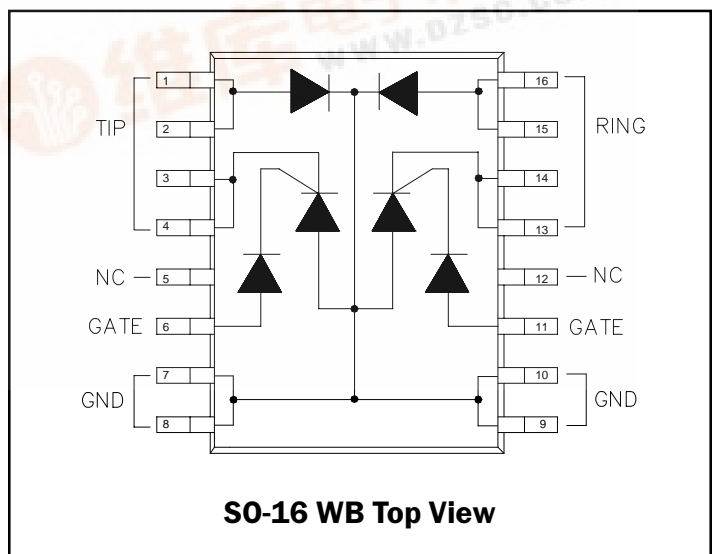

PROTECTION PRODUCTS
Absolute Maximum Rating

Rating	Symbol	Value	Units
Peak Pulse Current (tp = 10/1000µs)	I_{PP}	100	A
Peak Pulse Current (tp = 2/10µs)	I_{PP}	500	A
Continuous 60Hz Sinewave	I_{TSM}	60	A
Lead Soldering Temperature	T_L	260 (10 seconds)	°C
Operating Temperature	T_J	-55 to +125	°C
Storage Temperature	T_{STG}	-55 to +150	°C

Electrical Characteristics

TC04A-200						
Parameter	Symbol	Conditions	Minimum	Typical	Maximum	Units
Reverse Stand-Off Voltage	V_{DRM}	$T=25^{\circ}C$			-100	V
Switching Voltage	V_S	$I = I_S$		$-V_{BATT}-5V$		V
Reverse Clamping Voltage	V_C	$I_{PP} = 1A, tp = 10/1000\mu s$			2	V
		$I_{PP} = 30A, tp = 10/1000\mu s$			3	V
		$I_{PP} = 100A, tp = 10/1000\mu s$			12	V
Diode Forward Clamping Voltage	V_{CF}	$I_{PP} = 1A, tp = 10/1000\mu s$		1.2	2	V
		$I_{PP} = 30A, tp = 10/1000\mu s$		2.5	3	V
		$I_{PP} = 100A, tp = 10/1000\mu s$		4.2	5.5	V
On-State Voltage	V_T	$I_T = 1A$			3	V
Reverse Leakage Current	I_{DRM}	$V_{DRM} = -100V, T=25^{\circ}C$			5	µA
Switching Current (Gate Triggering Current)	I_S	$T=25^{\circ}C$		60		mA
Holding Current	I_H	$T=25^{\circ}C$	-200	-240		mA
Continuous On-State Current	I_T	$T=25^{\circ}C$			1	A
Off-State Capacitance	C_{OFF}	Between I/O pins & Gnd $V_R = 0V, f = 1MHz$		100		pF
		Between I/O pins & Gnd $V_R = -50V, f = 1MHz$		50		pF

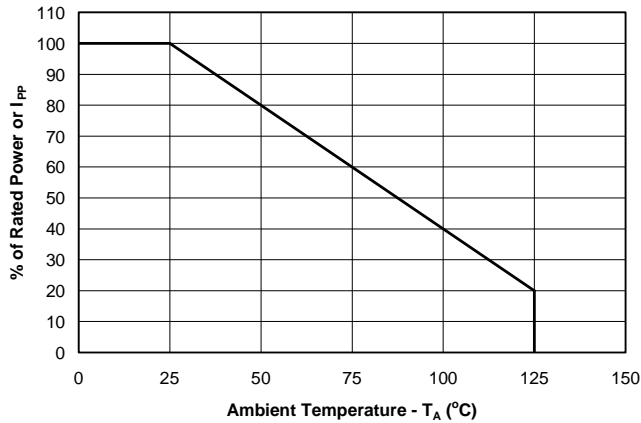
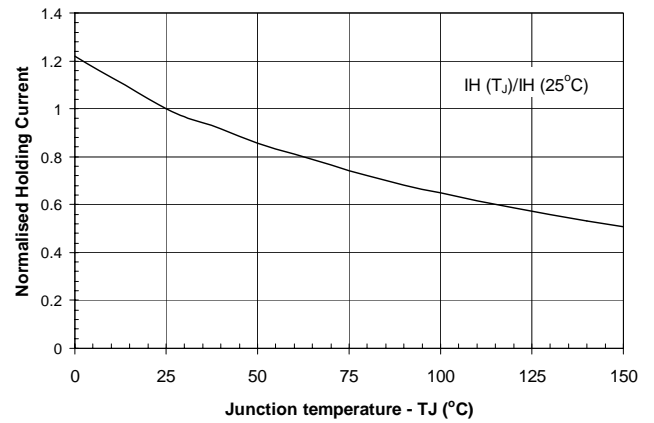
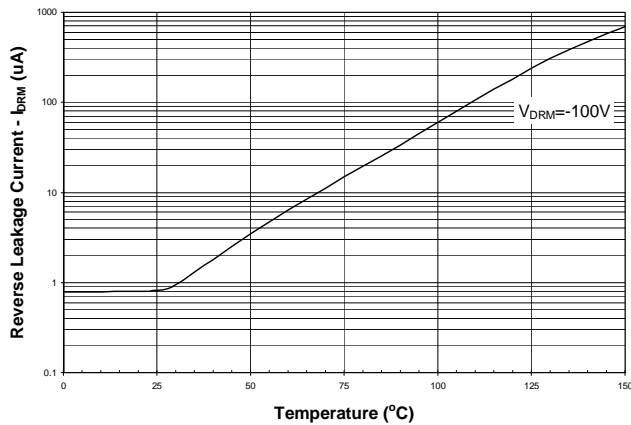
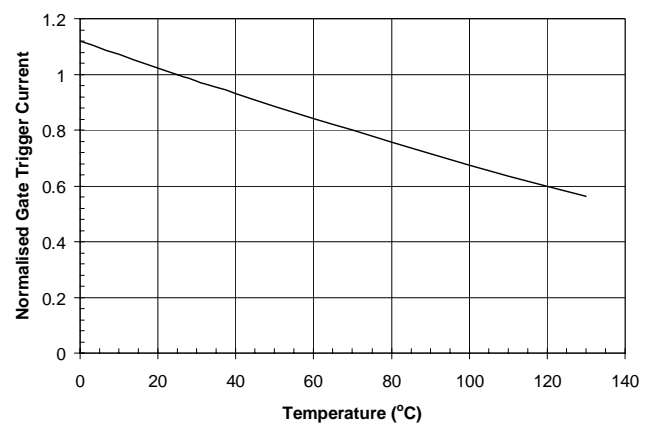
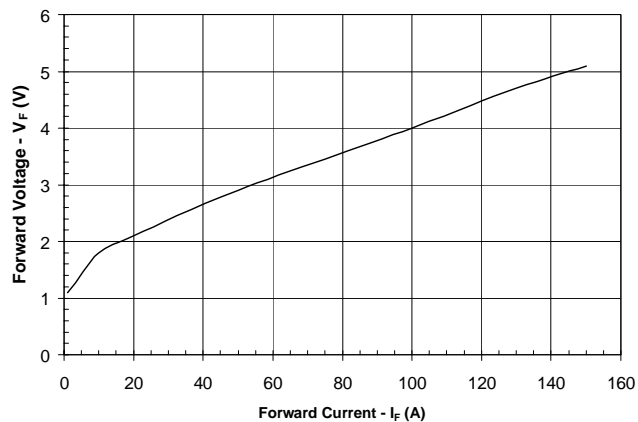
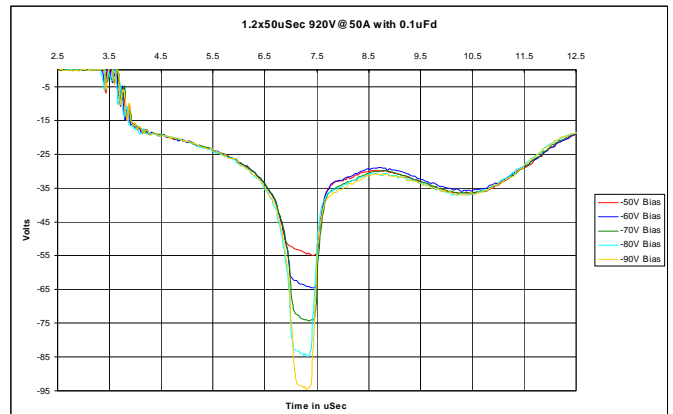
PROTECTION PRODUCTS
Typical Characteristics
Impulse Derating Curve

Normalized Holding Current vs. Temperature

Reverse Leakage Current vs. temperature

Normalized Gate Trigger Current vs. temperature

Diode Forward Voltage vs. Forward Current

Impulse Response Characteristic

PROTECTION PRODUCTS

Applications Information

SLIC protection Concepts

Transient immunity standards require telecommunications equipment be surged in all of its operating states. This refers to the “on-hook” state (ring generator or ring detection monitoring) and the “off-hook” state (operational state). The On-Hook state must allow for operation of the normal battery voltage and ring voltage without interference. The Off-Hook state only allows for operation of the battery voltage plus operation signals.

Several SLIC types exist. The first type of SLIC requires an external ring relay to disconnect the SLIC and connect the ringing and trip bias power supply generating the ringing signal. Protection must be provided for the subsystem which includes the ringing relay and ringing source. This type of ringing is sometimes called unbalanced ringing. The ringing voltage is typically inserted on the Ring (B-lead), while the Tip (A-lead) is grounded. The SLIC may or may not be protected by the ringing subsystem protection. Separate subsystem protection may be needed and must have a minimum operating voltage that exceeds the battery voltage and the ring signal voltage. The SLIC IC is disconnected from the line and the ring generator and does not see the ringing voltages. Therefore, the protection element for the SLIC must only have a minimum operating voltage greater than the battery supply voltage. This device must suppress all transients above ground and below the battery voltage.

The second SLIC type has an integrated ring generation capability. The protection device described in this application information is particularly suited for use with this SLIC type. Unlike the unbalanced system described above, these SLIC devices generate a balanced ring signal between Tip & Ring. The voltage on either line falls between the battery voltage and ground. Therefore, the SLIC protection device can have an operating voltage that is very close to the battery voltage. Since battery voltages may vary between talk and ringing states, it is desirable to utilize a programmable protection device so that the voltage across the SLIC does not exceed the process limits and the stress on the device is minimized.

SLIC Operating Voltages (Unbalanced Ringing)

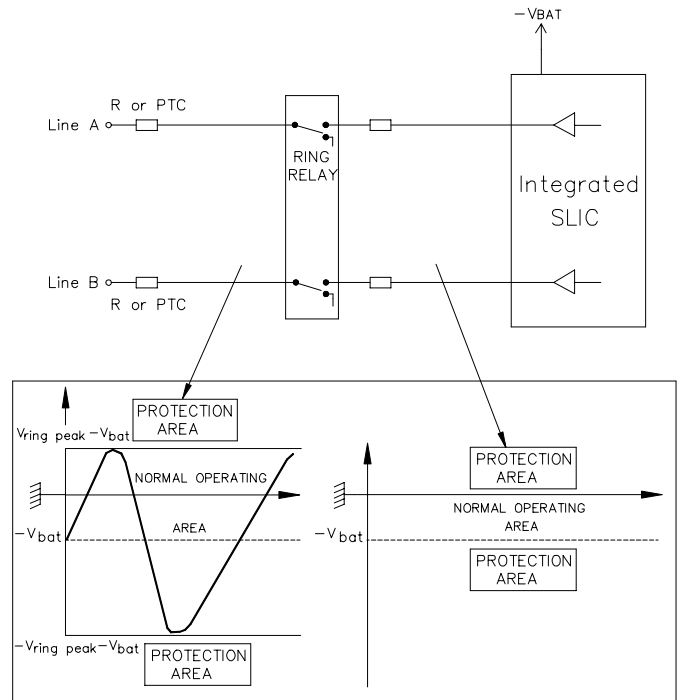

Balanced Ringing

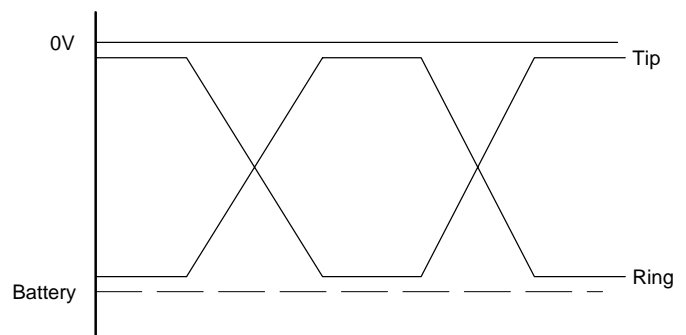

Protecting SLIC with Integrated Ring Generator

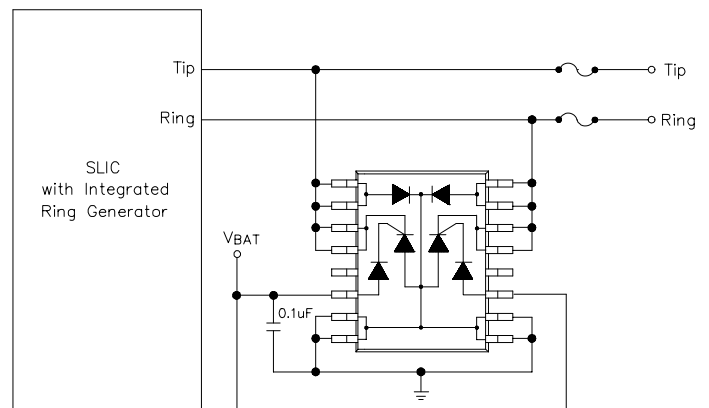

PROTECTION PRODUCTS

Applications Information (continued)

Operation of Battery Tracking TransClamp™

Telecommunications lines are vulnerable to transient disturbances from a variety of sources. Disturbances strike the line or near it and are then propagated to the extremities of the lines where sensitive electronics are located. The TransClamp series of thyristor surge suppressors are designed to protect sensitive telecom- munication equipment from transient voltages result- ing from lightning strikes and AC power line distur- bances.

The TC04A-200 utilizes internal diodes connected from each line to ground provide protection from positive overvoltages. During a positive duration transient, these internal diodes are forward biased shunting the transient current to ground. The voltage seen by the protected IC will be the forward clamping voltage (V_{CF}) of the diode. A gated TVS thyristor provides protection against negative surges. When the voltage on the Tip or Ring line falls below the reference voltage at the gate, the triggering diode begins to conduct forcing the TVS thyristor to crowbar (turn-on) to a low on-state voltage. The current required to trigger the thyristor is defined as the switching current (I_S). The maximum voltage seen by the protected IC will be the switching voltage (V_S). Once the transient subsides, the device will return to a high impedance (off-state) when the line current falls below the holding current (I_H). The high holding current of the TC04 prevents d.c. latch-up because the holding current is higher than the SLIC can source.

Protecting One SLIC Line Pair

The TC04A-200 battery tracking TransClamp is specifi- cally designed to protect subscriber line interface circuits (SLICs). The protection voltage of the device is referenced to the system's DC battery voltage. There- fore, the protection voltage will be essentially the same as the SLIC supply voltage, minimizing the stress on the protected device. The TC04A-200 may be refer- enced to battery voltages ranging from -5V to -100V. Pins 1-4 are connected to Tip line or A-lead and pins 13-16 are connected to the Ring line or B-lead. The battery feed voltage source is connected to the gate of the internal SCRs at pins 6 & 11. Pins 7-10 are connected to ground. All ground pins should be con- nected for best results. A 0.1 μ F capacitor is recom- mended between the gate & ground to speed up the triggering of the device.

TC04 Connection Diagram

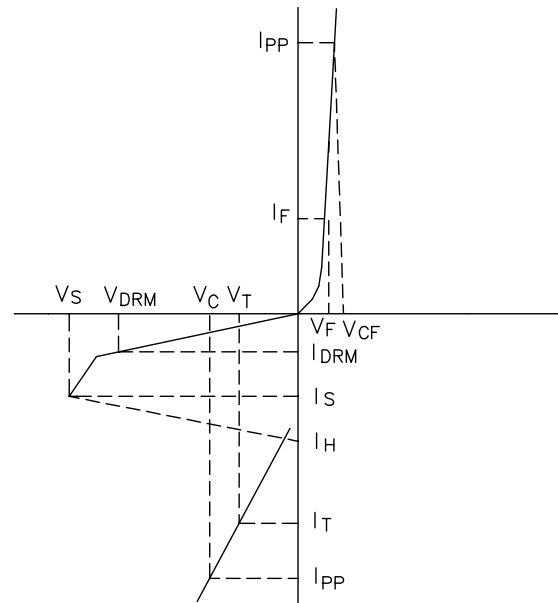
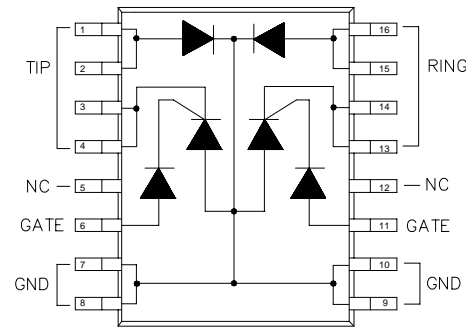

TC04 IV Characteristic Curve

Symbol	Parameter
V_{DRM}	Reverse Stand-Off (Off-State) Voltage
V_S	Switching Voltage
V_T	On-State Voltage
V_C	Reverse Clamping Voltage
V_F	Diode forward Voltage
V_{CF}	Forward Clamping Voltage
I_{DRM}	Reverse leakage (Off-State) Current
I_S	Switching Current (Gate Triggering Current)
I_T	On-State Current (Continuous)
I_H	Holding Current
I_{PP}	Peak Impulse Current

PROTECTION PRODUCTS

Typical Applications

Protecting Multiple SLIC Lines

The TC04A-200 may be used in conjunction with steering diodes to protect up to four SLIC Tip & Ring line pairs. The steering diodes shunt positive surges to ground. The internal diodes of the TC04A-200 may be used as one of the steering diode pairs as shown. In this configuration, each line pair may be surged to 100A ($t_p=10/100\mu s$) independantly, or all four pairs may be surged simultaneously up to 25A ($t_p=10/100\mu s$). This provides the designer with a flexible, cost effective solution and increased reliability over low current protection schemes. The surge immunity of the system may be further enhanced with the addition of line feed resistors (LFR). These devices are used for power cross protection and are designed to withstand lightning impulses per Bellcore GR-1089. Device with resistance values ranging from of 10W - 50W are common. A 0.1 μF capacitor is recommended between the gate & ground to speed up the triggering the device.

Note that the sum of the loop currents must not exceed the holding current of the TC04A-200. In the case of four twisted pairs, the individual loop currents would have to be limited to 50mA.

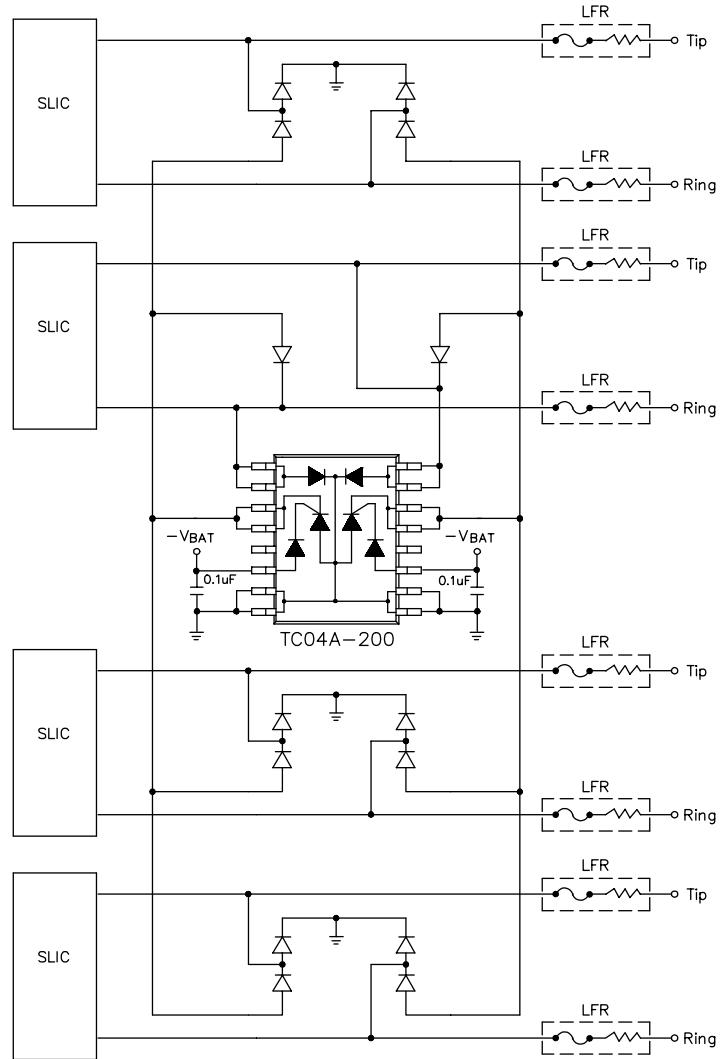

Component	Part Number	Source	Description
TVS	TC04A-200	Semtech	Battery Tracking TransClamp
Steering Diodes	ES1D	GSI	Ultrafast Surface Mount Rectifier
LFR	ALFR-2	IRC	Telecommunications Line Feed Resistor

PROTECTION PRODUCTS

Outline Drawing - SO-16 WB

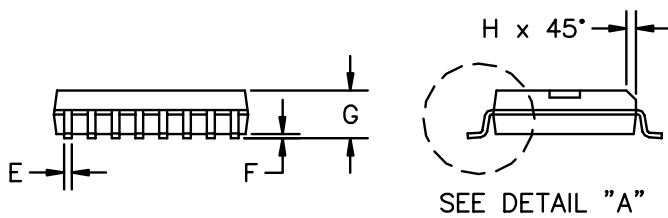
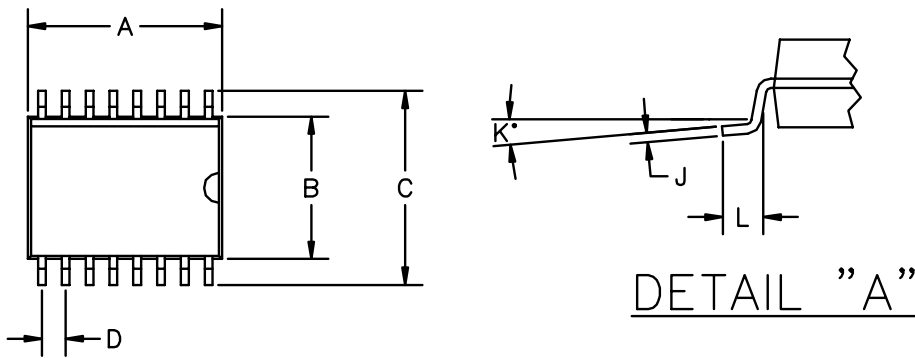

DIM ^N	DIMENSIONS				NOTE
	MM		INCHES		
	MIN	MAX	MIN	MAX	
A	10.2	10.4	.405	.409	2
B	7.54	7.65	.297	.301	2
C	10.2	10.5	.404	.415	
D	1.27	BSC	.050	BSC	
E	0.35	0.49	.014	.019	3
F	0.09	0.28	.004	.011	
G	2.36	2.65	.093	.104	
H	0.25	0.74	.010	.029	
J	0.25	0.31	.010	.012	3
K	0°	7°	0°	7°	
L	0.50	0.89	.020	.035	

Note 1: Controlling dimension : Inch (unless other wise specified).
 Note 2: Dimensions A and B do not include mold protrusions. Mold protrusions are .006" max.
 Note 3: Dimensions apply before solder dip on parts requiring solder dip.

Land Pattern - SO-16 WB

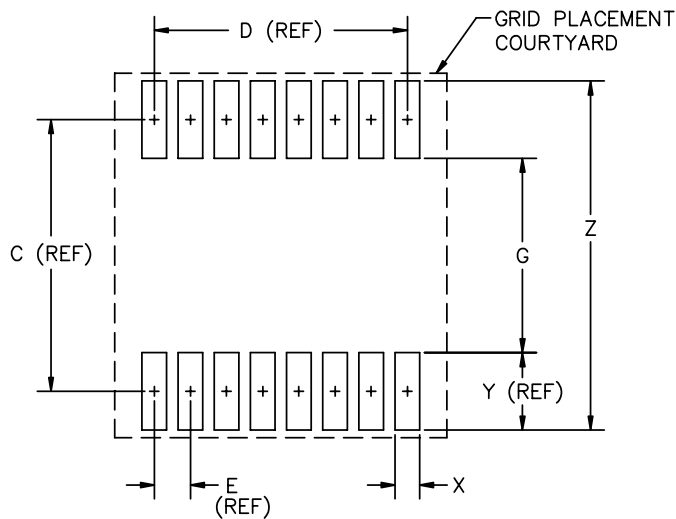

DIM ^N	DIMENSIONS (1)				NOTE
	INCHES		MM		
	MIN	MAX	MIN	MAX	
C	—	.36	—	9.20	—
D	—	.35	—	8.89	—
E	—	.05	—	1.27	—
G	.25	.27	6.60	6.80	—
X	.02	.03	.60	.80	—
Y	—	.10	—	2.60	—
Z	.45	.48	11.60	11.80	—

Note 1 : Controlling dimension is millimeters
 Note 2 : Grid placement courtyard is 22 x 24 elements (11mm x 12mm) in accordance with the international grid detailed in IEC publication 97.



TC04A-200

PROTECTION PRODUCTS

Ordering Information

Part Number	Holding Current	Qty per Reel	Reel Size
TC04A-200.TD	200mA	1,000	13 Inch

Note:

(1) No suffix indicates tube pack.

Contact Information

Semtech Corporation
Protection Products Division
652 Mitchell Rd., Newbury Park, CA 91320
Phone: (805)498-2111 FAX (805)498-3804