

TC35095P 8 BIT 8-CH SERIAL I/O ANALOG TO DIGITAL CONVERTER

GENERAL DESCRIPTION

The TC35095P is a monolithic CMOS 8 bit successive approximation A/D converter with serial I/O and 8 channel multiplex inputs.

Conversion start when \overline{CS} is set low and start bit ("L" level) and channel select bit (three bits) are given to serial input DI.

In case that \overline{SE} is high, as soon as the conversion starts a start bit ("L" level) appears at serial output DO and 8 bit conversion data (MSB first) and a stop bit ("H" level) follow continuously.

In case that \overline{SE} is low, after the conversion is completed a start bit, 8 bit conversion data (LSB first) and a stop bit appear at DO.

The TC35095P has features of high speed, high accuracy and microprocessor compatible I/O which make the device well suited to a broad application field such as process and machine control and automotive equipment.

FEATURES

- High accuracy $\pm \frac{3}{4}$ LSB MAX
- High speed conversion 35 μ sec MAX @ $f_{cp}=400$ kHz
- Single Power supply 5V \pm 10%
- Low Power consumption 5mW MAX @ $T_a=25^\circ\text{C}$
- Serial I/O
- 8 channel analog multiplex input
- Easy interface to all microprocessors
- 3-state output
- Zero or full scale adjustment free

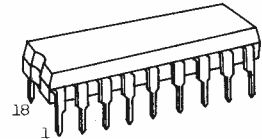

DIP18(3D18A-P)

ABSOLUTE MAXIMUM RATINGS

PARAMETER	SYMBOL	VALUE	UNIT
Supply Voltage Range	V _{DD}	V _{SS} -0.5~V _{SS} +7	V
DC Input Voltage	V _{IN}	V _{SS} -0.5~V _{DD} +0.5	V
DC Output Voltage	V _{OUT}	V _{SS} -0.5~V _{DD} +0.5	V
Reference Voltage	V _{REF}	V _{SS} -0.5~V _{DD} +0.5	V
Analog Ground Voltage	A _{GND}	V _{SS} -0.5~V _{DD} +0.5	V
DC Input Current	I _{IN}	± 10	mA
Power Dissipation	P _d	300	mW
Storage Temperature	T _{stg}	-65 ~ 150	$^\circ\text{C}$
Lead Temperature 10sec.	T _L	300	$^\circ\text{C}$

PIN ASSIGNMENT

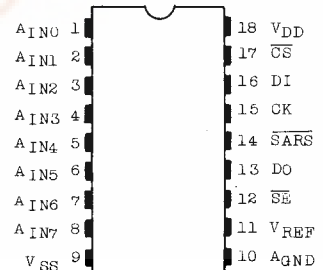

(TOP VIEW)



TC35095P

BLOCK DIAGRAM

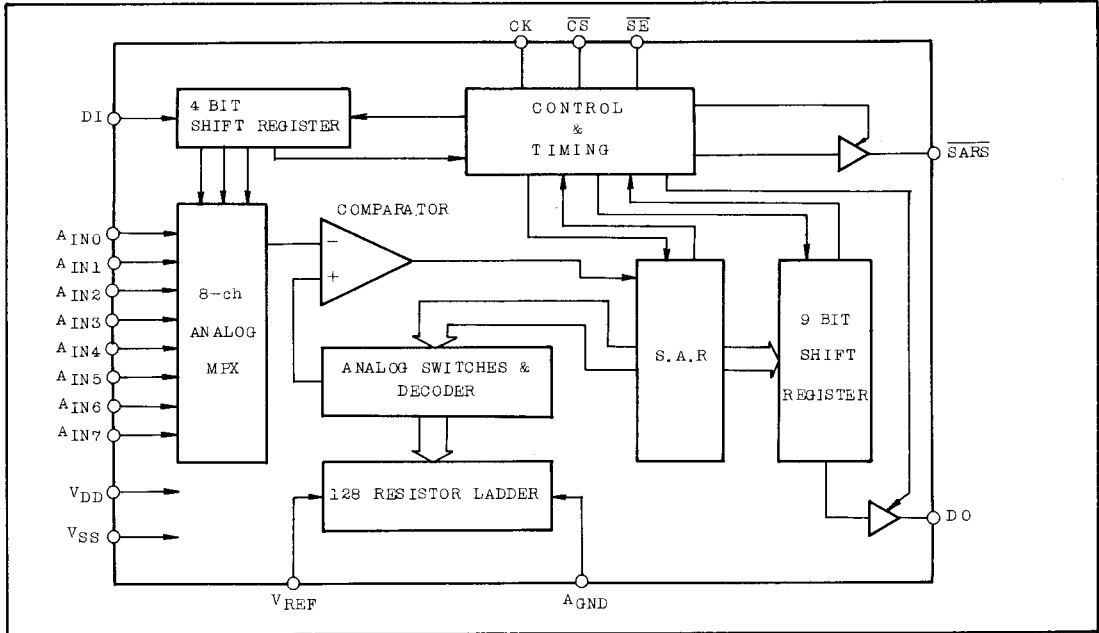

TIMING CHART

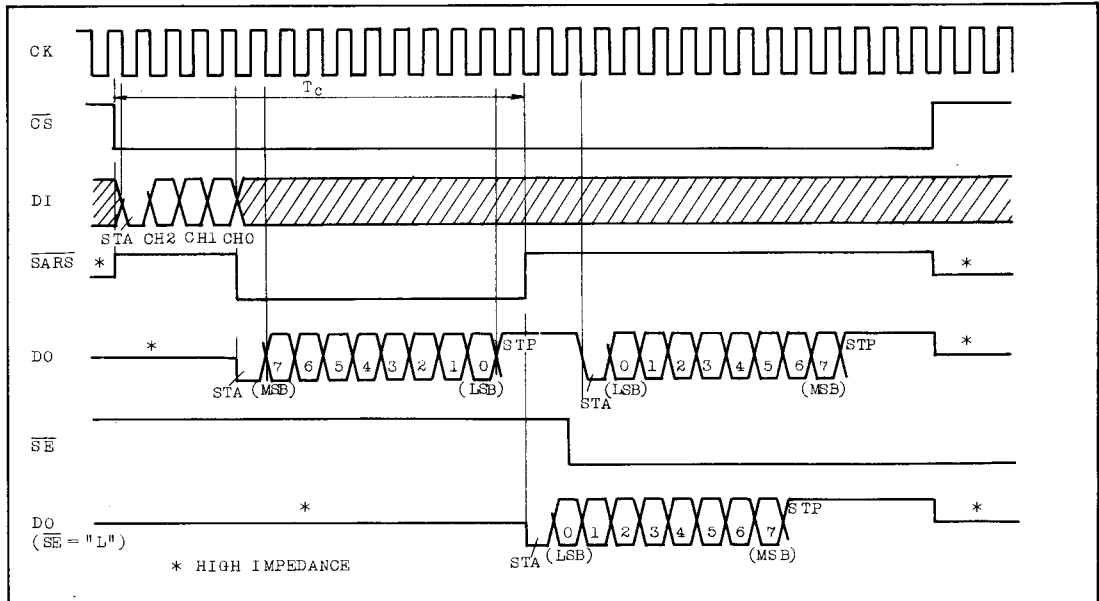

PIN & FUNCTION

PIN NO.	SYMBOL	PIN NAME & FUNCTION	PIN NO.	SYMBOL	PIN NAME & FUNCTION																																							
1	A _{IN0}	<p>[ANALOG INPUT]</p> <p>One of A_{IN0} ~ A_{IN7} is selected according to the serial channel select bit applied on DI input. Full range of input signal is to be from A_{GND} to V_{REF}.</p> <table border="1" style="margin: 10px auto;"> <thead> <tr> <th rowspan="2">ON Channel</th> <th colspan="3">DI Serial Data</th> </tr> <tr> <th>CH2</th> <th>CH1</th> <th>CH0</th> </tr> </thead> <tbody> <tr> <td>A_{IN0}</td> <td>L</td> <td>L</td> <td>L</td> </tr> <tr> <td>A_{IN1}</td> <td>L</td> <td>L</td> <td>H</td> </tr> <tr> <td>A_{IN2}</td> <td>L</td> <td>H</td> <td>L</td> </tr> <tr> <td>A_{IN3}</td> <td>L</td> <td>H</td> <td>H</td> </tr> <tr> <td>A_{IN4}</td> <td>H</td> <td>L</td> <td>L</td> </tr> <tr> <td>A_{IN5}</td> <td>H</td> <td>L</td> <td>H</td> </tr> <tr> <td>A_{IN6}</td> <td>H</td> <td>H</td> <td>L</td> </tr> <tr> <td>A_{IN7}</td> <td>H</td> <td>H</td> <td>H</td> </tr> </tbody> </table>	ON Channel	DI Serial Data			CH2	CH1	CH0	A _{IN0}	L	L	L	A _{IN1}	L	L	H	A _{IN2}	L	H	L	A _{IN3}	L	H	H	A _{IN4}	H	L	L	A _{IN5}	H	L	H	A _{IN6}	H	H	L	A _{IN7}	H	H	H	10	A _{GND}	[ANALOG GROUND] A _{GND} defines the zero level of A _{IN} .
ON Channel	DI Serial Data																																											
	CH2		CH1	CH0																																								
A _{IN0}	L		L	L																																								
A _{IN1}	L		L	H																																								
A _{IN2}	L		H	L																																								
A _{IN3}	L		H	H																																								
A _{IN4}	H		L	L																																								
A _{IN5}	H		L	H																																								
A _{IN6}	H	H	L																																									
A _{IN7}	H	H	H																																									
2	A _{IN1}	11	V _{REF}	[REFERENCE VOLTAGE] V _{REF} defines the full scale of A _{IN} .																																								
3	A _{IN2}	12	\overline{SE}	[SELECT INPUT] \overline{SE} determines the order of output data. SE="L" LSB first SE="H" MSB first																																								
4	A _{IN3}	13	DO	[DATA OUTPUT] Output data is sent out in series.																																								
5	A _{IN4}	14	\overline{SARS}	[SAR STATUS] When a start bit ("L" level) is detected at DI input, \overline{SARS} is set "L" level and conversion starts. When conversion is completed \overline{SARS} returns to "H" level.																																								
6	A _{IN5}	15	CK	[CLOCK INPUT] Basic system clock. Duty cycle is to be 50%.																																								
7	A _{IN6}	16	DI	[DATA INPUT] For starting the conversion a start bit ("L" level) and channel select bit (from CH2 to CH0 in order) are to be applied.																																								
8	A _{IN7}	17	\overline{CS}	[CHIP SELECT] At the falling edge of \overline{CS} , the device is set stand-by for conversion. When \overline{CS} is "H" the device is reset and all outputs become high impedance.																																								
9	V _{SS}	[DIGITAL GROUND]	18	V _{DD}	[Power Supply] 5V ± 10%																																							

TC35095P

RECOMMENDED OPERATING CONDITIONS (V_{SS}=0V)

PARAMETER	SYMBOL	CONDITION	MIN.	TYP.	MAX.	UNIT
Supply Voltage	V _{DD}		4.5	5.0	5.5	V
Input Voltage	V _{IN}		0	-	V _{DD}	V
Reference Voltage	V _{REF}	V _{DD} =5V, A _{GND} =0V	2.0	V _{DD}	V _{DD}	V
Analog Ground Voltage	A _{GND}	V _{DD} =5V, V _{REF} =5V	0.0	0.0	3.0	V
Voltage Between V _{REF} and A _{GND}		V _{DD} =5V±10%	2.0	V _{DD}	V _{DD}	V
Clock Frequency	f _{CP}	V _{DD} =5V±10%	-	-	400	kHz
Clock Pulse Width	t _{w(H)} t _{w(L)}	V _{DD} =5V±10%	0.63	1.25	-	μs
Operating Temperature	T _{opr}		-40	-	+85	°C

DC ELECTRICAL CHARACTERISTICS (V_{DD}=5V ± 10%, V_{SS}=0V)

PARAMETER	SYMBOL	TEST CONDITION	25°C			-40 ~ 85°C		UNIT
			MIN.	TYP.	MAX.	MIN.	MAX.	
High Level Output Voltage	V _{OH}	I _{OUT} < 1μA V _{IN} =V _{SS} , V _{DD}	V _{DD} -0.05	V _{DD}	-	V _{DD} -0.05	-	V
Low Level Output Voltage	V _{OL}	I _{OUT} < 1μA V _{IN} =V _{SS} , V _{DD}	-	0.00	0.05	-	0.05	V
High Level Output Current	I _{OH}	V _{OH} =V _{DD} -0.4V V _{IN} =V _{SS} , V _{DD}	-0.44	-	-	-0.36	-	mA
Low Level Output Current	I _{OL}	V _{OL} =0.4V V _{IN} =V _{SS} , V _{DD}	2.0	-	-	1.6	-	mA
High Level Input Voltage	V _{IH}	I _{OUT} < 1μA V _{OUT} =0.5V, V _{DD} -0.5V	0.7 × V _{DD}	-	-	0.7 × V _{DD}	-	V
Low Level Input Voltage	V _{IL}	I _{OUT} < 1μA V _{OUT} =0.5V, V _{DD} -0.5V	-	-	0.3 × V _{DD}	-	0.3 × V _{DD}	V
3-State Output Disable Current	I _{DH} I _{DL}	V _{OH} =V _{DD} or V _{OL} =0.0V	-	-	±0.5	-	±1	μA
Digital Input Current	I _{IH} I _{IL}	V _{IH} =V _{DD} or V _{IL} =0.0V	-	-	±0.3	-	±1	μA
ON Channel Input Current	I _{ON}	V _{IH} =V _{REF} or V _{IL} =0.0V f _{CP} =400kHz	-	-	±2	-	±5	μA
OFF Channel Input Current	I _{OFF}	V _{IH} =V _{DD} or V _{IL} =0.0V	-	-	±0.2	-	±1	μA
Operating Current	I _{DD}	f _{CP} =400kHz	-	-	1.1	-	1.4	mA
Reference Resistance	R _{REF}		1.4	2.6	3.8	1.2	4.2	kΩ

SWITCHING CHARACTERISTICS (V_{DD}=5V±10%, V_{SS}=0V, Ta=25°C)

PARAMETER	SYMBOL	TEST CONDITION	MIN.	TYP.	MAX.	UNIT
Output Transition Time	t_{TLH} t_{THL}	C _L =50pF	-		100	nS
Propagation Delay Time (CK-Data)	t_{pLH} t_{pHL}	C _L =50pF	-		250	
Propagation Delay Time (CK-SARS)	t_{pLH} t_{pHL}	C _L =50pF	-		250	
3-State Output Enable Time (CS-SARS, SARS-Data)	t_{pZH} t_{pZL}	C _L =50pF	-		200	
3-State Output Disable Time (CS-SARS, Data)	t_{pHZ} t_{pLZ}	R _L =1k	-		200	
Minimum Pulse Width (CS)	$t_{w(H)}$	C _L =50pF	-		100	
Minimum Set-up Time (CS, SE, DI)	t_s	C _L =50pF	-		150	
Minimum Hold Time (DI)	t_h	C _L =50pF	-		50	
Input Capacitance	C _{IN1}	Digital Input	-	5	-	pF
Input Capacitance	C _{IN2}	Analog In(ON)	-	5	-	
Input Capacitance	C _{IN3}	Analog In(OFF)	-	5	-	
Output Capacitance	C _{OUT}	3-State Out	-	10	-	

SWITCHING CHARACTERISTICS TEST WAVEFORM

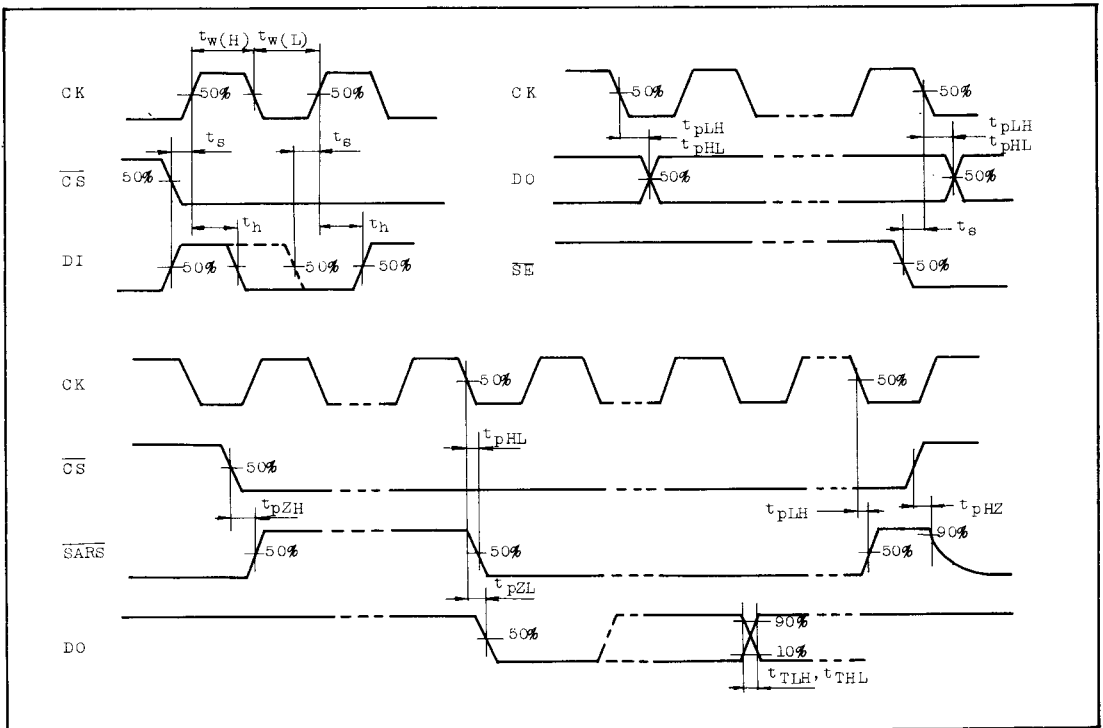

TC35095P

3-STATE OUTPUT TEST CIRCUIT

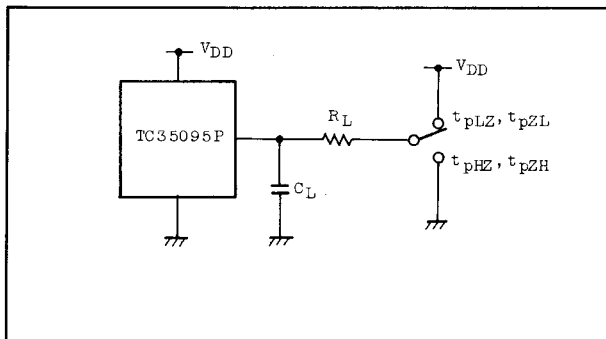

SYSTEM CHARACTERISTICS ($T_a = -40 \sim 85^\circ\text{C}$)

PARAMETER	SYMBOL	TEST CONDITION	MIN.	TYP.	MAX.	UNIT
Zero Point Error	E_{ZR}	$V_{DD} = 5.0V$ $V_{REF} = 5.000V$ $f_{cp} = 400kHz$ Duty = 50%	-	$\pm 1/4$	$\pm 1/2$	LSB
Full Scale Error	E_{FS}		-	$\pm 1/4$	$\pm 1/2$	
Nonlinearity Error	E_{LI}		-	$\pm 1/4$	-	
Total Error	E_T		-	$\pm 1/4$	$\pm 3/4$	
Conversion Time	T_C	$f_{cp} = 400kHz$	-	35	36.5	μS

APPLICATION CIRCUIT (EXAMPLE)

$$T_c = \frac{14}{f_{cp}} \pm \alpha \quad 0 < \alpha < \frac{1}{2f_{cp}}$$

