

TOSHIBA CMOS DIGITAL INTEGRATED CIRCUIT SILICON MONOLITHIC

TC4024BP, TC4024BF, TC4024BFN

TC4024B 7 STAGE RIPPLE - CARRY BINARY COUNTER / DIVIDERS

TC4024B is 7 stage ripple carry type binary counter having asynchronous clear function.

The counter advances its counting state by falling edge of $\overline{\text{CLOCK}}$ input.

When RESET input is placed at "H", all the internal flip-flop are reset making all the outputs Q1 through Q7 to be "L" regardless of $\overline{\text{CLOCK}}$ input.

This is suitable for frequency divider circuits and control circuits.

(Note) The JEDEC SOP (FN) is not available in Japan.

MAXIMUM RATINGS

CHARACTERISTIC	SYMBOL	RATING	UNIT
DC Supply Voltage	V_{DD}	$V_{SS} - 0.5 \sim V_{SS} + 20$	V
Input Voltage	V_{IN}	$V_{SS} - 0.5 \sim V_{DD} + 0.5$	V
Output Voltage	V_{OUT}	$V_{SS} - 0.5 \sim V_{DD} + 0.5$	V
DC Input Current	I_{IN}	± 10	mA
Power Dissipation	P_D	300 (DIP) / 180 (SOIC)	mW
Operating Temperature Range	T_{opr}	-40~85	°C
Storage Temperature Range	T_{stg}	-65~150	°C

TRUTH TABLE

$\overline{\text{CLOCK}} \Delta$	RESET	OUTPUT STAGE
*	H	All Outputs = "L"
	L	No Change
	L	Advance to Next State

Δ : Level Change, *: Don't Care

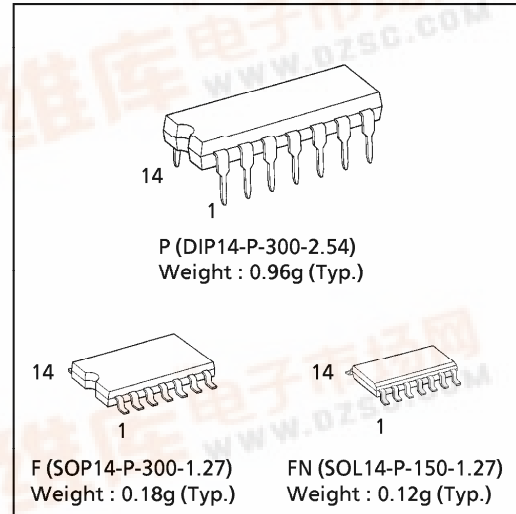

PIN ASSIGNMENT

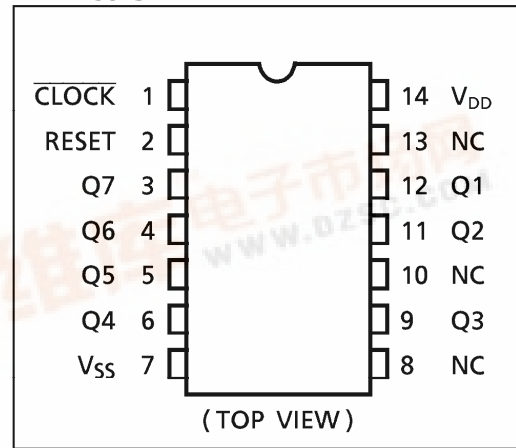

LOGIC DIAGRAM

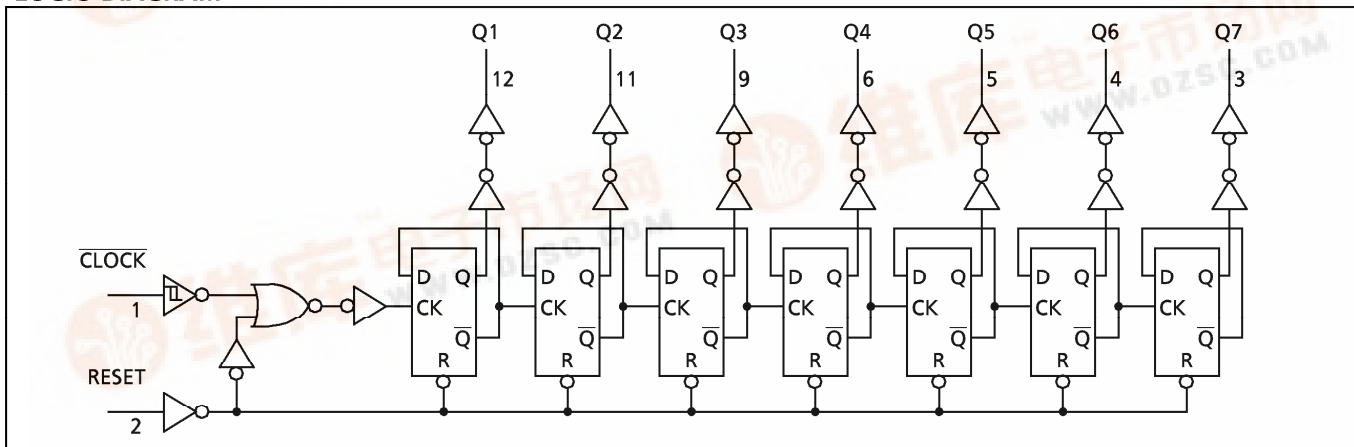

961001EBA2

TOSHIBA is continually working to improve the quality and the reliability of its products. Nevertheless, semiconductor devices in general can malfunction or fail due to their inherent electrical sensitivity and vulnerability to physical stress. It is the responsibility of the buyer, when utilizing TOSHIBA products, to observe standards of safety, and to avoid situations in which a malfunction or failure of a TOSHIBA product could cause loss of human life, bodily injury or damage to property. In developing your designs, please ensure that TOSHIBA products are used within specified operating ranges as set forth in the most recent products specifications. Also, please keep in mind the precautions and conditions set forth in the TOSHIBA Semiconductor Reliability Handbook.

RECOMMENDED OPERATING CONDITIONS (V_{SS} = 0V)

CHARACTERISTIC	SYMBOL	TEST CONDITION	MIN.	TYP.	MAX.	UNIT
DC Supply Voltage	V _{DD}		3	—	18	V
Input Voltage	V _{IN}		0	—	V _{DD}	V

STATIC ELECTRICAL CHARACTERISTICS (V_{SS} = 0V)

CHARACTERISTIC	SYM-BOL	TEST CONDITION	V _{DD} (V)	-40°C		25°C			85°C		UNIT	
				MIN.	MAX.	MIN.	TYP.	MAX.	MIN.	MAX.		
High-Level Output Voltage	V _{OH}	I _{OUT} < 1μA V _{IN} = V _{SS}	5	4.95	—	4.95	5.00	—	4.95	—	V	
			10	9.95	—	9.95	10.00	—	9.95	—		
			15	14.95	—	14.95	15.00	—	14.95	—		
Low-Level Output Voltage	V _{OL}	I _{OUT} < 1μA V _{IN} = V _{SS} , V _{DD}	5	—	0.05	—	0.00	0.05	—	0.05	V	
			10	—	0.05	—	0.00	0.05	—	0.05		
			15	—	0.05	—	0.00	0.05	—	0.05		
Output High Current	I _{OH}	V _{OH} = 4.6V V _{OH} = 2.5V V _{OH} = 9.5V V _{OH} = 13.5V V _{IN} = V _{SS} , V _{DD}	5	-0.61	—	-0.51	-1.0	—	-0.42	—	mA	
			5	-2.50	—	-2.10	-4.0	—	-1.70	—		
			10	-1.50	—	-1.30	-2.2	—	-1.10	—		
			15	-4.00	—	-3.40	-9.0	—	-2.80	—		
Output Low Current	I _{OL}	V _{OL} = 0.4V V _{OL} = 0.5V V _{OL} = 1.5V V _{IN} = V _{SS} , V _{DD}	5	0.61	—	0.51	1.2	—	0.42	—	mA	
			10	1.50	—	1.30	3.2	—	1.10	—		
			15	4.00	—	3.40	12.0	—	2.80	—		
			5	3.5	—	3.5	2.75	—	3.5	—		
Input High Voltage	V _{IH}	V _{OUT} = 0.5V, 4.5V V _{OUT} = 1.0V, 9.0V V _{OUT} = 1.5V, 13.5V I _{OUT} < 1μA	10	7.0	—	7.0	5.50	—	7.0	—	V	
			15	11.0	—	11.0	8.25	—	11.0	—		
			5	—	1.5	—	2.25	1.5	—	1.5		—
Input Low Voltage	V _{IL}	V _{OUT} = 0.5V, 4.5V V _{OUT} = 1.0V, 9.0V V _{OUT} = 1.5V, 13.5V I _{OUT} < 1μA	10	—	3.0	—	4.50	3.0	—	3.0	V	
			15	—	4.0	—	6.75	4.0	—	4.0		
			5	—	—	—	—	—	—	—		—
Input Current	"H" Level	I _{IH}	V _{IH} = 18V	18	—	0.1	—	10 ⁻⁵	0.1	—	1.0	μA
	"L" Level	I _{IL}	V _{IL} = 0V	18	—	-0.1	—	-10 ⁻⁵	-0.1	—	-1.0	
Quiescent Supply Current	I _{DD}	V _{IN} = V _{SS} , V _{DD} *	5	—	5	—	0.005	5	—	150	μA	
			10	—	10	—	0.010	10	—	300		
			15	—	15	—	0.015	20	—	600		

* All valid input combinations.

DYNAMIC ELECTRICAL CHARACTERISTICS (Ta = 25°C, Vss = 0V, CL = 50pF)

CHARACTERISTIC	SYMBOL	TEST CONDITION	V _{DD} (V)	MIN.	TYP.	MAX.	UNIT
Output Transition Time (Low to High)	t _{TLH}		5	—	70	200	ns
			10	—	35	100	
			15	—	30	80	
Output Transition Time (High to Low)	t _{THL}		5	—	70	200	
			10	—	35	100	
			15	—	30	80	
Propagation Delay Time (CLOCK - Q1)	t _{pLH}		5	—	140	360	
			10	—	70	160	
			15	—	50	130	
Propagation Delay Time (CLOCK - Q1)	t _{pHL}		5	—	140	360	
			10	—	70	160	
			15	—	50	130	
Propagation Delay Time (CLOCK - Q7)	t _{pLH}		5	—	400	1200	
			10	—	160	520	
			15	—	115	430	
Propagation Delay Time (CLOCK - Q7)	t _{pHL}		5	—	400	1200	
			10	—	160	520	
			15	—	115	430	
Propagation Delay Time (RESET - Q)	t _{pHL}		5	—	140	280	
			10	—	70	120	
			15	—	50	100	
Max. Clock Frequency	f _{CL}		5	3.5	14	—	MHz
			10	8.0	30	—	
			15	12.0	40	—	
Max. Clock Input Rise Time Max. Clock Input Fall Time	t _{rCL} t _{fCL}		5	No Limit			μs
			10				
			15				
Max. Clock Pulse Width	t _w		5	—	40	140	ns
			10	—	20	60	
			15	—	15	40	
Max. Pulse Width (RESET)	t _{WH}		5	—	40	200	
			10	—	20	80	
			15	—	15	60	
Minimum Removal Time	t _{rem}		5	—	0	350	
			10	—	0	150	
			15	—	0	100	
Input Capacitance	C _{IN}			—	5	7.5	

WAVEFORMS FOR MEASUREMENT OF DYNAMIC CHARACTERISTICS

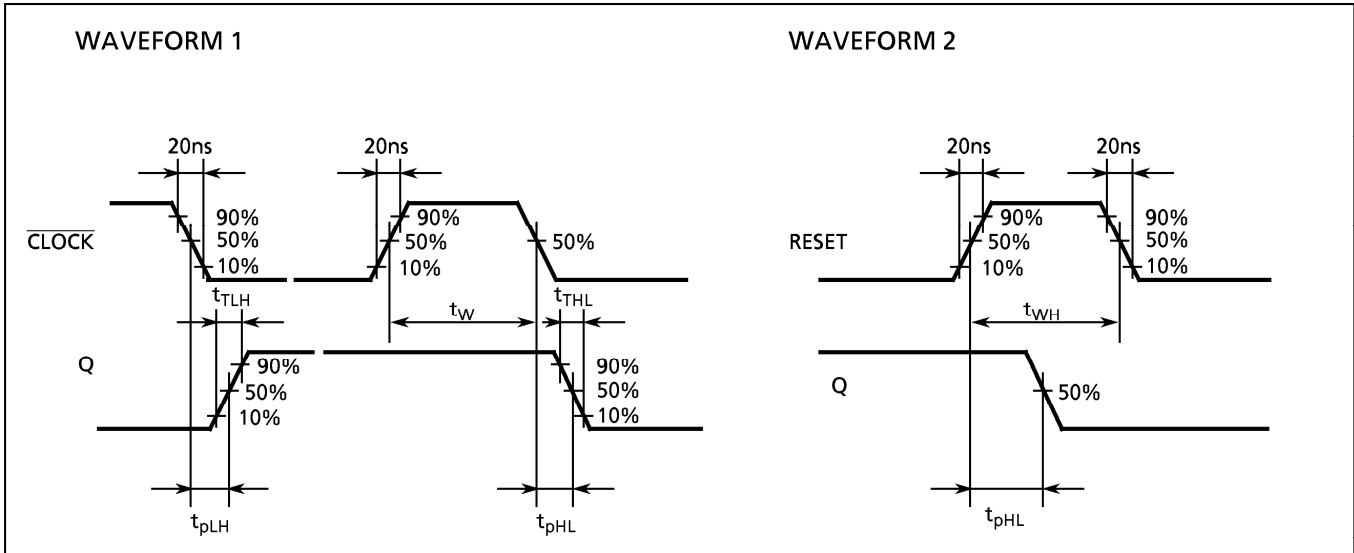

DIP 14PIN OUTLINE DRAWING (DIP14-P-300-2.54)

Unit in mm

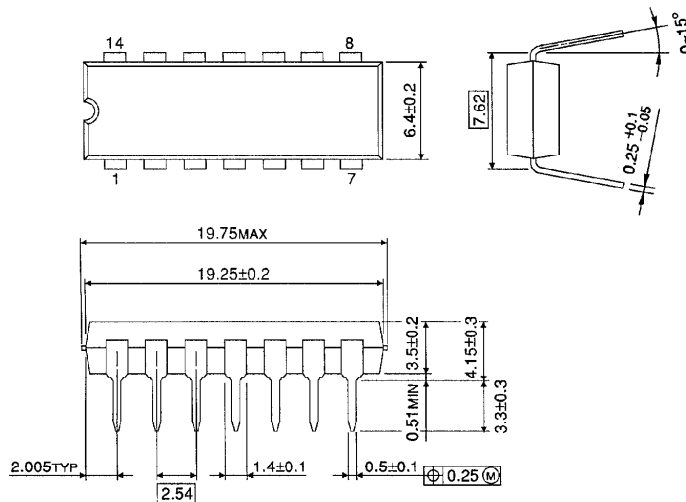

Weight : 0.96g (Typ.)

SOP 14PIN (200mil BODY) OUTLINE DRAWING (SOP14-P-300-1.27)

Unit in mm

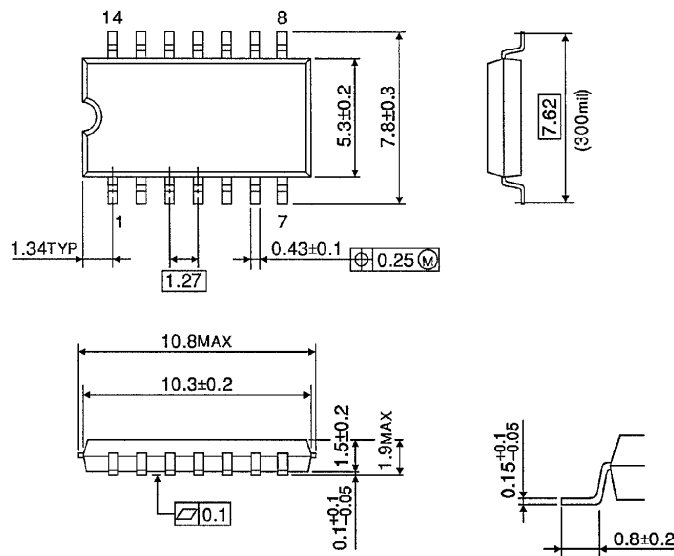

Weight : 0.18g (Typ.)

SOP 14PIN (150mil BODY) OUTLINE DRAWING (SOL14-P-150-1.27)

Unit in mm

(Note) This package is not available in Japan.

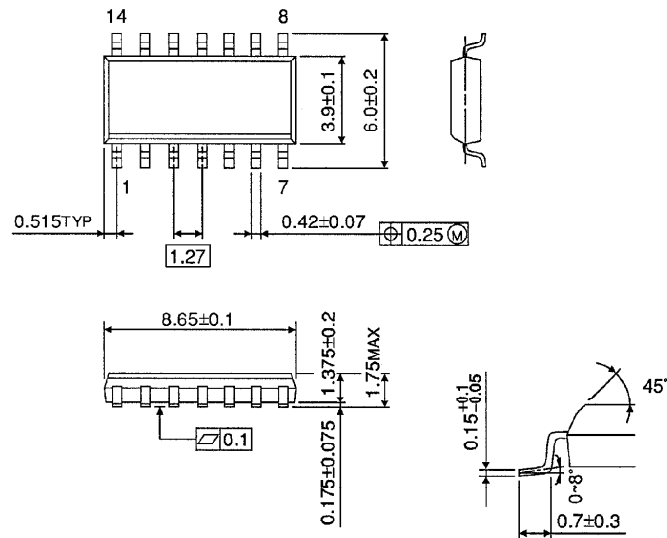

Weight : 0.12g (Typ.)