

TOSHIBA CMOS DIGITAL INTEGRATED CIRCUIT SILICON MONOLITHIC

TC4094BP, TC4094BF, TC4094BFN

TC4094B 8 - STAGE SHIFT - AND - STORE BUSREGISTE

TC4094B is a SHIFT and STORE REGISTER that consists of an 8-bit shift register and an 8-bit latch. The read data in the shift register can be taken in the latch through the asynchronous STROBE input; therefore, the data transfer mode can hold output. And, since the parallel outputs is of 3-state construction, it can be directly connected to the 8-bit busline.

This register can be applied to Serial - to - parallel conversion, data receivers, etc.

(Note) The JEDEC SOP (FN) is not available in Japan.

MAXIMUM RATINGS

CHARACTERISTIC	SYMBOL	RATING	UNIT
DC Supply Voltage	V_{DD}	$V_{SS} - 0.5 \sim V_{SS} + 20$	V
Input Voltage	V_{IN}	$V_{SS} - 0.5 \sim V_{DD} + 0.5$	V
Output Voltage	V_{OUT}	$V_{SS} - 0.5 \sim V_{DD} + 0.5$	V
DC Input Current	I_{IN}	± 10	mA
Power Dissipation	P_D	300 (DIP) / 180 (SOIC)	mW
Operating Temperature Range	T_{opr}	$-40 \sim 85$	$^{\circ}C$
Storage Temperature Range	T_{stg}	$-65 \sim 150$	$^{\circ}C$

BLOCK DIAGRAM

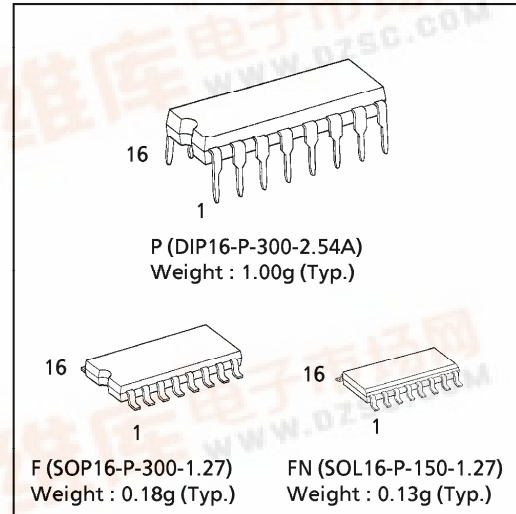
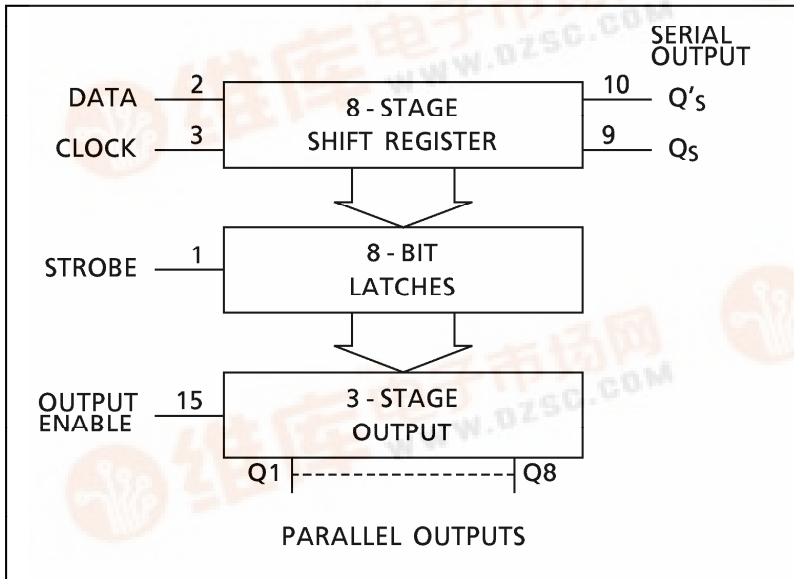

PIN ASSIGNMENT

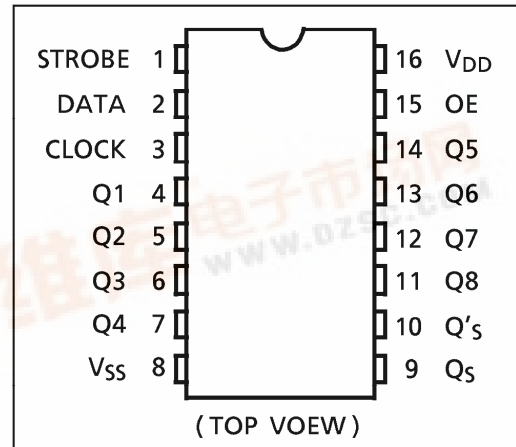

TRUTH TABLE

CL	OE	ST	D	PO		SO	
				Q1	Qn	Qs	Q's
\uparrow	H	H	L	L	Qn - 1	Q7	NC
\uparrow	H	H	H	H	Qn - 1	Q7	NC
\uparrow	H	L	X	NC	NC	Q7	NC
\uparrow	L	X	X	HZ	HZ	Q7	NC
\downarrow	H	X	X	NC	NC	NC	Qs
\downarrow	L	X	X	HZ	HZ	NC	Qs

CL = Clock
OE = Output Eneble
ST = Strobe
D = Data
PO = Parallel Outputs
SO = Serial Output

X = Don't Care
NC = No Change
HZ = High Impedance

LOGIC DIAGRAM

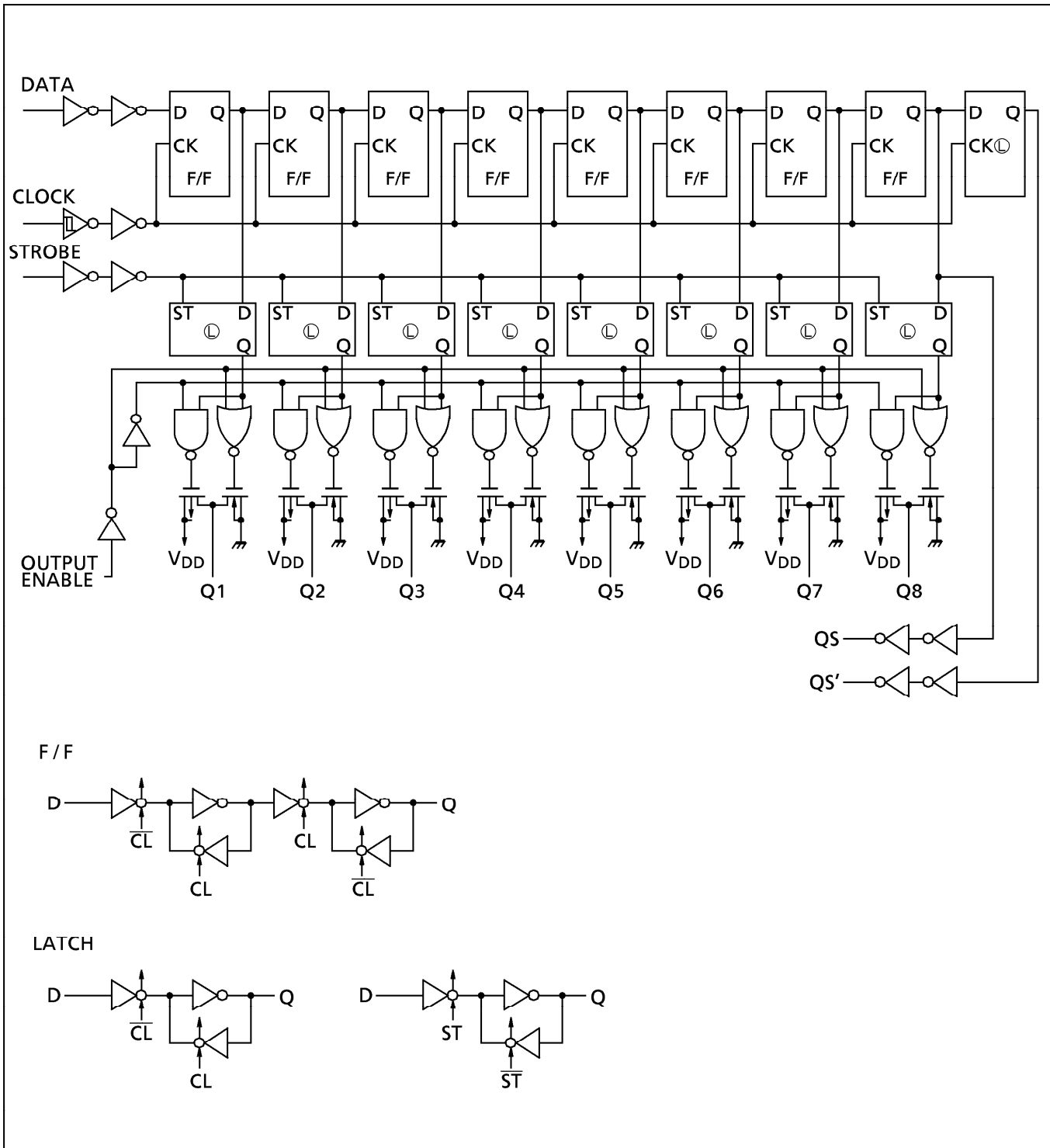

961001EBA2'

● The products described in this document are subject to foreign exchange and foreign trade control laws.
 ● The information contained herein is presented only as a guide for the applications of our products. No responsibility is assumed by TOSHIBA CORPORATION for any infringements of intellectual property or other rights of the third parties which may result from its use. No license is granted by implication or otherwise under any intellectual property or other rights of TOSHIBA CORPORATION or others.
 ● The information contained herein is subject to change without notice.

TIMING CHART

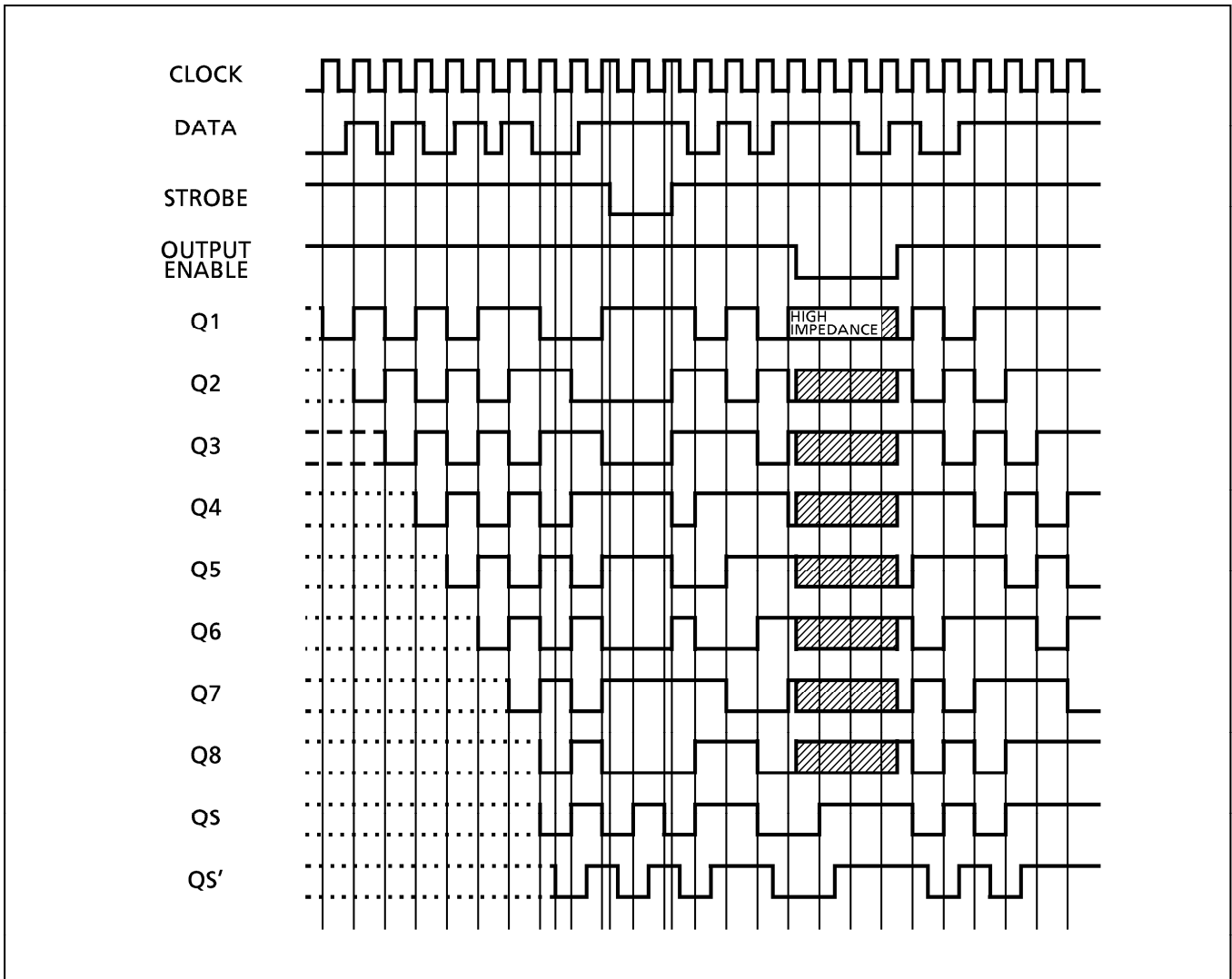

RECOMMENDED OPERATING CONDITIONS (V_{SS} = 0V)

CHARACTERISTIC	SYMBOL	TEST CONDITION	MIN.	TYP.	MAX.	UNITS
DC Supply Voltage	V _{DD}		3	—	18	V
Input Voltage	V _{IN}		0	—	V _{DD}	V

STATIC ELECTRICAL CHARACTERISTICS (V_{SS} = 0V)

CHARACTERISTIC	SYM-BOL	TEST CONDITION	V _{DD} (V)	- 40°C		25°C			85°C		UNIT
				MIN.	MAX.	MIN.	TYP.	MAX.	MIN.	MAX.	
High-Level Output Voltage	V _{OH}	I _{OUT} < 1μA V _{IN} = V _{SS} , V _{DD}	5	4.95	—	4.95	5.00	—	4.95	—	V
			10	9.95	—	9.95	10.00	—	9.95	—	
			15	14.95	—	14.95	15.00	—	14.95	—	
Low-Level Output Voltage	V _{OL}	I _{OUT} < 1μA V _{IN} = V _{SS} , V _{DD}	5	—	0.05	—	0.00	0.05	—	0.05	V
			10	—	0.05	—	0.00	0.05	—	0.05	
			15	—	0.05	—	0.00	0.05	—	0.05	
Output High Current	I _{OH}	V _{OH} = 4.6V V _{OH} = 2.5V V _{OH} = 9.5V V _{OH} = 13.5V V _{IN} = V _{SS} , V _{DD}	5	-0.61	—	-0.51	-1.0	—	-0.42	—	mA
			5	-2.50	—	-2.10	-4.0	—	-1.70	—	
			10	-1.50	—	-1.30	-2.2	—	-1.10	—	
			15	-4.00	—	-3.40	-9.0	—	-2.80	—	
Output Low Current	I _{OL}	V _{OL} = 0.4V V _{OL} = 0.5V V _{OL} = 1.5V V _{IN} = V _{SS} , V _{DD}	5	0.61	—	0.51	1.2	—	0.42	—	mA
			10	1.50	—	1.30	3.2	—	1.10	—	
			15	4.00	—	3.40	12.0	—	2.80	—	
			5	—	1.5	—	2.25	1.5	—	1.5	
Input High Voltage	V _{IH}	V _{OUT} = 0.5V, 4.5V V _{OUT} = 1.0V, 9.0V V _{OUT} = 1.5V, 13.5V I _{OUT} < 1μA	5	3.5	—	3.5	2.75	—	3.5	—	V
			10	7.0	—	7.0	5.50	—	7.0	—	
			15	11.0	—	11.0	8.25	—	11.0	—	
			5	—	3.0	—	4.50	3.0	—	3.0	
Input Low Voltage	V _{IL}	V _{OUT} = 0.5V, 4.5V V _{OUT} = 1.0V, 9.0V V _{OUT} = 1.5V, 13.5V I _{OUT} < 1μA	10	—	4.0	—	6.75	4.0	—	4.0	
			15	—	4.0	—	6.75	4.0	—	4.0	
			18	—	0.1	—	10 ⁻⁵	0.1	—	1.0	
			18	—	-0.1	—	-10 ⁻⁵	-0.1	—	-1.0	
3-State Output Leakage Current	"H" Level	I _{DH}	V _{OUT} = 18V	18	—	0.4	—	10 ⁻⁴	0.4	—	12
	"L" Level	I _{DL}	V _{OUT} = 0V	18	—	-0.4	—	-10 ⁻⁴	-0.4	—	-12
Quiescent Supply Current	I _{DD}	V _{IN} = V _{SS} , V _{DD} *	5	—	5	—	0.005	5	—	150	μA
			10	—	10	—	0.010	10	—	300	
			15	—	20	—	0.015	20	—	600	

* All valid input combinations.

DYNAMIC ELECTRICAL CHARACTERISTICS (Ta = 25°C, Vss = 0V, CL = 50pF)

CHARACTERISTIC	SYMBOL	TEST CONDITION	V _{DD} (V)	MIN.	TYP.	MAX.	UNIT
Output Transition Time (Low to High)	t _{TLH}		5	—	70	200	ns
			10	—	35	100	
			15	—	30	80	
Output Transition Time (High to Low)	t _{THL}		5	—	70	200	
			10	—	35	100	
			15	—	30	80	
Propagation Delay Time (CLOCK - Q _S)	t _{pLH} t _{pHL}		5	—	150	600	
			10	—	75	250	
			15	—	55	190	
Propagation Delay Time (CLOCK - Q _S ')	t _{pLH} t _{pHL}		5	—	155	460	
			10	—	75	220	
			15	—	55	150	
Propagation Delay Time (CLOCK - Q _n)	t _{pLH} t _{pHL}		5	—	190	840	
			10	—	90	390	
			15	—	65	270	
Propagation Delay Time (STROBE - Q _n)	t _{pLH} t _{pHL}		5	—	150	580	
			10	—	70	290	
			15	—	50	200	
Three State Disable Time (OUTPUT ENABLE - Q _n)	t _{pHZ} t _{pZH}	R _L = 1kΩ	5	—	60	200	
			10	—	35	100	
			15	—	30	80	
Three State Disable Time (OUTPUT ENABLE - Q _n)	t _{pLZ} t _{pZL}	R _L = 1kΩ	5	—	70	200	
			10	—	40	100	
			15	—	35	80	
Min. Clock Pulse Width	t _w		5	—	45	200	
			10	—	20	100	
			15	—	15	80	
Min. Pulse Width (STROBE)	t _{WH}		5	—	40	200	
			10	—	20	80	
			15	—	15	70	
Max. Clock Frequency	f _{CL}		5	1.25	6	—	
			10	2.50	12	—	
			15	3.00	16	—	
Min. Set-up Time (DATA - CLOCK)	t _{SU}		5	—	0	125	
			10	—	0	55	
			15	—	0	35	
Min. Hold Time (DATA - CLOCK)	t _H		5	—	10	40	
			10	—	10	20	
			15	—	5	15	
Min. Set-up Time (CLOCK - STROBE)	t _{SU}		5	—	90	200	
			10	—	40	100	
			15	—	30	80	
Min. Hold Time (CLOCK - STROBE)	t _H		5	—	—	0	
			10	—	—	0	
			15	—	—	0	
Max. Clock Input Rise Time Max. Clock Input Fall Time	t _{rCL} t _{fCL}		5	No Limit			μs
			10 15				
Input Capacitance	C _{IN}			—	5	7.5	pF

WAVEFORMS FOR MEASUREMENT OF DYNAMIC CHARACTERISTICS

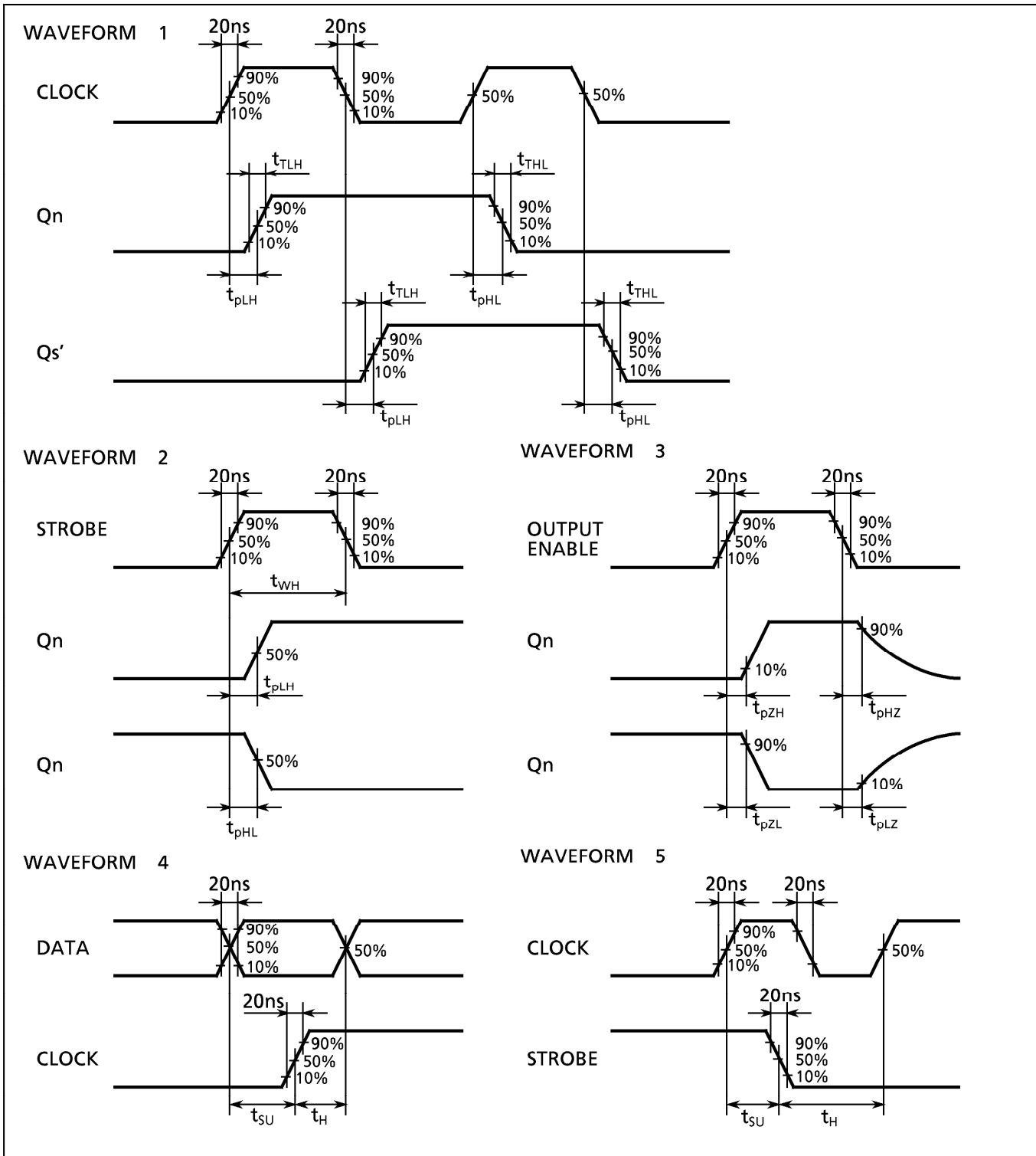

DIP 16PIN OUTLINE DRAWING (DIP16-P-300-2.54A)

Unit in mm

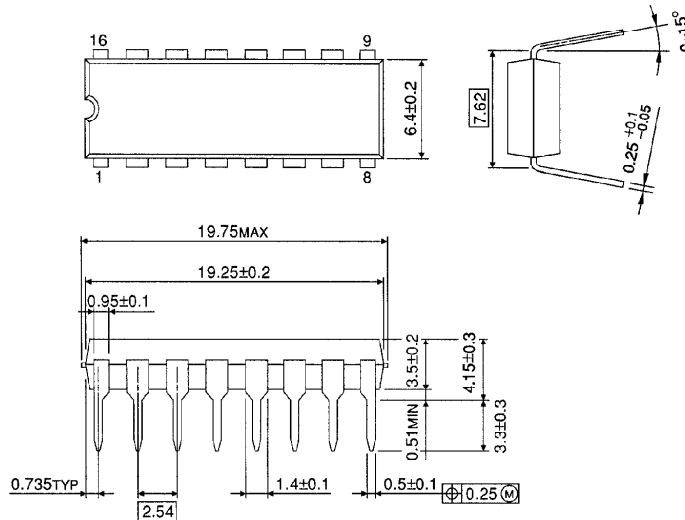

Weight : 1.00g (Typ.)

SOP 16PIN (200mil BODY) OUTLINE DRAWING (SOP16-P-300-1.27)

Unit in mm

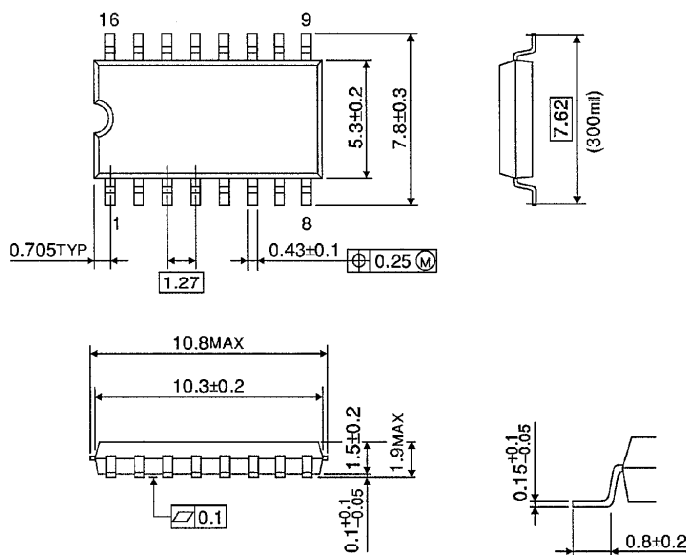

Weight : 0.18g (Typ.)

SOP 16PIN (150mil BODY) OUTLINE DRAWING (SOL16-P-150 -1.27)

Unit in mm

(Note) This package is not available in Japan.

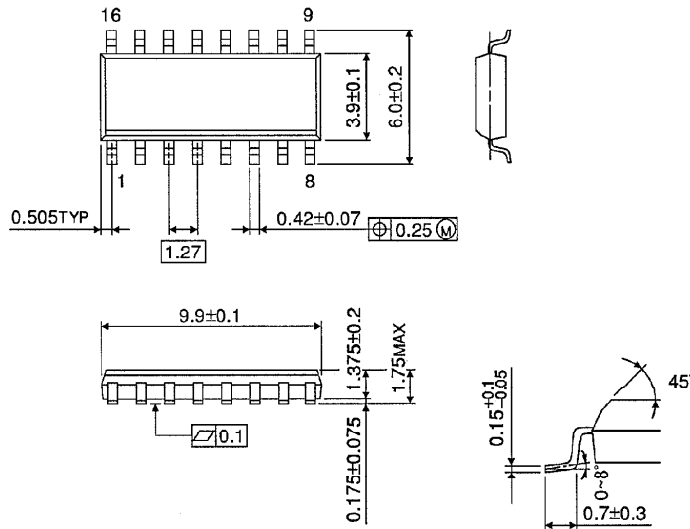

Weight : 0.13g (Typ.)