



TC682

INVERTING VOLTAGE DOUBLER

FEATURES

- 99.9% Voltage Conversion Efficiency
- 92% Power Conversion Efficiency
- Wide Input Voltage Range +2.4V to +5.5V
- Only 3 External Capacitors Required
- 185µA Supply Current
- Space-Saving 8-Pin SOIC and 8-Pin Plastic DIP Packages

APPLICATIONS

- - 10V from +5V Logic Supply
- - 6V from a Single 3V Lithium Cell
- Portable Handheld Instruments
- Cellular Phones
- LCD Display Bias Generator
- Panel Meters
- Operational Amplifier Power Supplies

TYPICAL OPERATING CIRCUIT

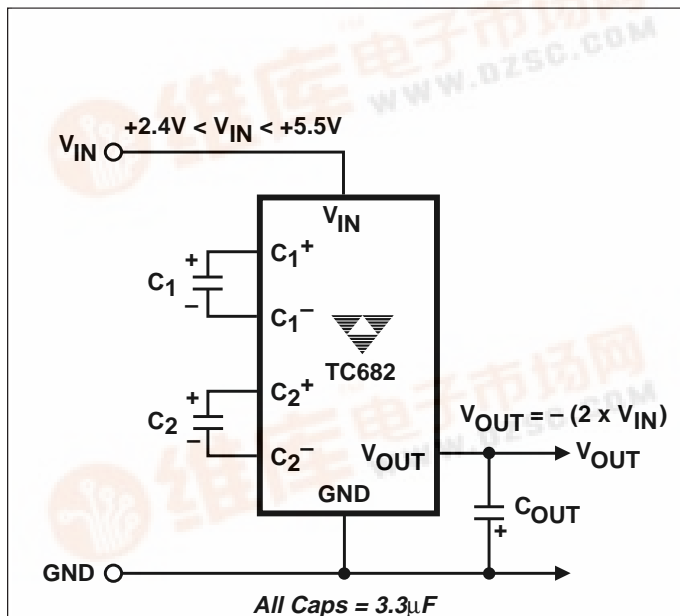

GENERAL DESCRIPTION

The TC682 is a CMOS charge pump converter that provides an inverted doubled output from a single positive supply. An on-board 12kHz (typical) oscillator provides the clock and only 3 external capacitors are required for full circuit implementation.

Low output source impedance (typically 140Ω), provides output current up to 10mA. The TC682 features low quiescent current and high efficiency, making it the ideal choice for a wide variety of applications that require a negative voltage derived from a single positive supply (for example: generation of -6V from a 3V lithium cell or -10V generated from a +5V logic supply).

The minimum external parts count and small physical size of the TC682 make it useful in many medium-current, dual voltage analog power supplies.

ORDERING INFORMATION

Part No.	Package	Temp. Range
TC682COA	8-Pin SOIC	0°C to +70°C
TC682CPA	8-Pin Plastic DIP	0°C to +70°C
TC682EOA	8-Pin SOIC	-40°C to +85°C
TC682EPA	8-Pin Plastic DIP	-40°C to +85°C
TC7660EV	Evaluation Kit for Charge Pump Family	

PIN CONFIGURATIONS

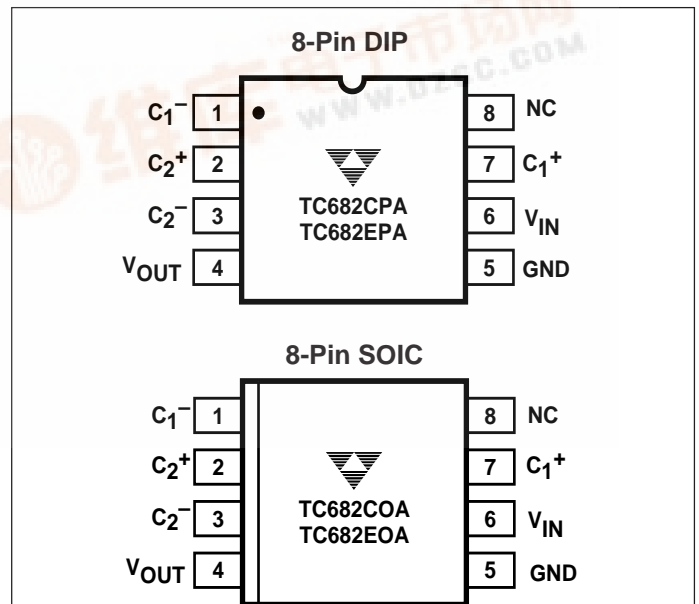

INVERTING VOLTAGE DOUBLER

TC682

ABSOLUTE MAXIMUM RATINGS*

V_{IN}	+5.8V
V_{IN} dV/dT	1V/ μ sec
V_{OUT}	- 11.6V
V_{OUT} Short-Circuit Duration	Continuous
Power Dissipation ($T_A \leq 70^\circ\text{C}$)	
Plastic DIP	730mW
SOIC	470mW
Storage Temperature Range	- 65°C to +150°C
Lead Temperature (Soldering, 10 sec)	+300°C

*This is a stress rating only and functional operation of the device at these or any other conditions above those indicated in the operational sections of the specifications is not implied. Exposure to Absolute Maximum Rating Conditions for extended periods may affect device reliability.

ELECTRICAL CHARACTERISTICS: Over Operating Temperature Range, $V_{IN} = +5V$, test circuit Figure 1, unless otherwise indicated.

Symbol	Parameter	Test Conditions	Min	Typ	Max	Unit
V_{IN}	Supply Voltage Range	$R_L = 2k\Omega$	2.4	—	5.5	V
I_{IN}	Supply Current	$R_L = \infty, T_A = 25^\circ\text{C}$ $R_L = \infty$	—	185	300	μA
R_{OUT}	V_{OUT} Source Resistance Source Resistance	$I_L^- = 10\text{mA}, T_A = 25^\circ\text{C}$	—	140	180	Ω
		$I_L^- = 10\text{mA}$	—	—	230	
		$I_L^- = 5\text{mA}, V_{IN} = 2.8V$	—	170	320	
F_{OSC}	Oscillator Frequency		—	12	—	kHz
P_{EFF}	Power Efficiency	$R_L = 2k\Omega, T_A = 25^\circ\text{C}$	90	92	—	%
$V_{OUT EFF}$	Voltage Conversion Efficiency	$V_{OUT}, R_L = \infty$	99	99.9	—	%

TelCom Semiconductor reserves the right to make changes in the circuitry or specifications detailed in this manual at any time without notice. Minimums and maximums are guaranteed. All other specifications are intended as guidelines only. TelCom Semiconductor assumes no responsibility for the use of any circuits described herein and makes no representations that they are free from patent infringement.

PIN DESCRIPTION

Pin No.	Symbol	Description
1	C_1^-	Input. Capacitor C1 negative terminal.
2	C_2^+	Input. Capacitor C2 positive terminal.
3	C_2^-	Input. Capacitor C2 negative terminal.
4	V_{OUT}	Output. Negative output voltage (- 2 V_{IN})
5	GND	Input. Device ground.
6	V_{IN}	Input. Power supply voltage.
7	C_1^+	Input. Capacitor C1 positive terminal.
8	N/C	No Connection

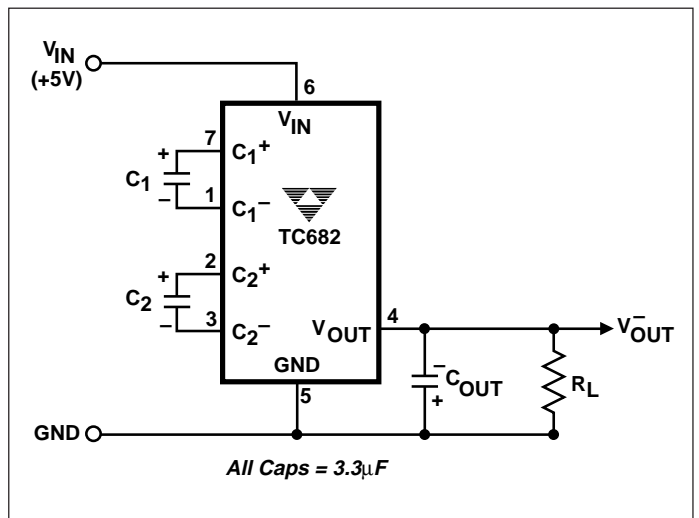

Figure 1. TC682 Test Circuit

INVERTING VOLTAGE DOUBLER

DETAILED DESCRIPTION

Phase 1

V_{SS} charge storage – before this phase of the clock cycle, capacitor C_1 is already charged to +5V. C_1^+ is then switched to ground and the charge in C_1^- is transferred to C_2^- . Since C_2^+ is at +5V, the voltage potential across capacitor C_2 is now -10V.

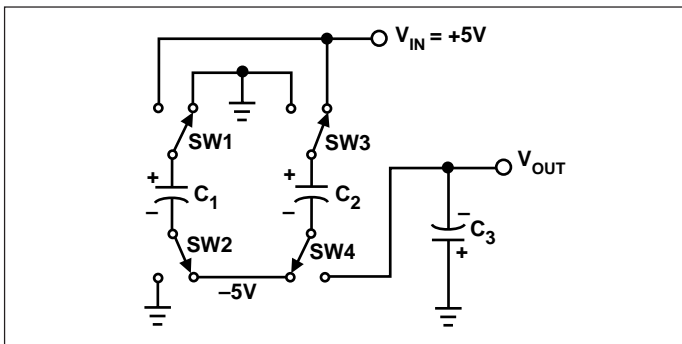

Figure 2. Charge Pump – Phase 1

Phase 2

V_{SS} transfer – phase two of the clock connects the negative terminal of C_2 to the negative side of reservoir capacitor C_3 and the positive terminal of C_2 to ground, transferring the generated -10V to C_3 . Simultaneously, the positive side of capacitor C_1 is switched to +5V and the negative side is connected to ground. C_2 is then switched to V_{CC} and GND and Phase 1 begins again.

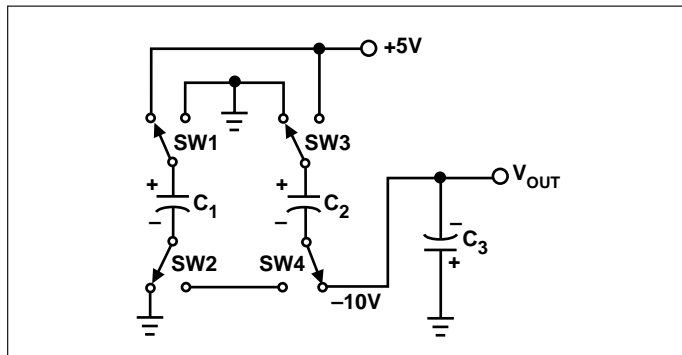

Figure 3. Charge Pump – Phase 2

MAXIMUM OPERATING LIMITS

The TC682 has on-chip zener diodes that clamp V_{IN} to approximately 5.8V, and V_{OUT} to -11.6V. Never exceed the maximum supply voltage or excessive current will be shunted by these diodes, potentially damaging the chip. The TC682 will operate over the entire operating temperature range with an input voltage of 2V to 5.5V.

EFFICIENCY CONSIDERATIONS

Theoretically a charge pump voltage multiplier can approach 100% efficiency under the following conditions:

- The charge pump switches have virtually no offset and are extremely low on resistance.
- Minimal power is consumed by the drive circuitry
- The impedances of the reservoir and pump capacitors are negligible.

For the TC682, efficiency is as shown below:

$$\begin{aligned} \text{Voltage Efficiency} &= V_{OUT} / (-2V_{IN}) \\ V_{OUT} &= -2V_{IN} + V_{DROP} \\ V_{DROP} &= (I_{OUT}) (R_{OUT}) \end{aligned}$$

$$\text{Power Loss} = I_{OUT} (V_{DROP})$$

There will be a substantial voltage difference between V_{OUT} and $2 V_{IN}$ if the impedances of the pump capacitors C_1 and C_2 are high with respect to their respective output loads.

Larger values of reservoir capacitor C_3 will reduce output ripple. Larger values of both pump and reservoir capacitors improve the efficiency. See "Capacitor Selection" in Applications section.

APPLICATIONS

Negative Doubling Converter

The most common application of the TC682 is as a charge pump voltage converter which provides a negative output of two times a positive input voltage (Figure 4).

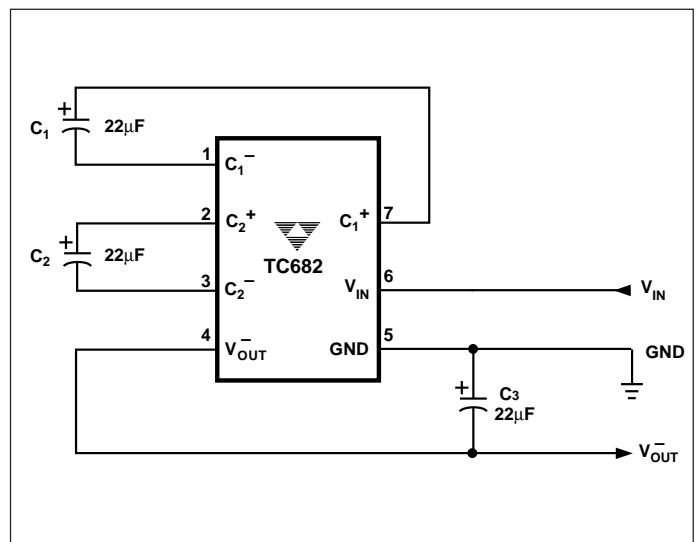

Figure 4. Inverting Voltage Doubler

INVERTING VOLTAGE DOUBLER

TC682

Capacitor Selection

The output resistance of the TC682 is determined, in part, by the ESR of the capacitors used. An expression for R_{OUT} is derived as shown below:

$$R_{OUT} = 2(R_{SW1} + R_{SW2} + ESR_{C1} + R_{SW3} + R_{SW4} + ESR_{C2}) + 2(R_{SW1} + R_{SW2} + ESR_{C1} + R_{SW3} + R_{SW4} + ESR_{C2}) + 1/(f_{PUMP} \times C1) + 1/(f_{PUMP} \times C2) + ESR_{C3}$$

Assuming all switch resistances are approximately equal...

$$R_{OUT} = 16R_{SW} + 4ESR_{C1} + 4ESR_{C2} + ESR_{C3} + 1/(f_{PUMP} \times C1) + 1/(f_{PUMP} \times C2)$$

R_{OUT} is typically 140Ω at +25°C with $V_{IN} = +5V$ and 3.3μF low ESR capacitors. The fixed term (16 R_{SW}) is about 80-90Ω. It can be seen easily that increasing or decreasing values of C1 and C2 will affect efficiency by changing R_{OUT} . However, be careful about ESR. This term can quickly become dominant with large electrolytic capacitors. Table 1 shows R_{OUT} for various values of C1 and C2 (assume 0.5Ω ESR). C1 must be rated at 6VDC or greater while C2 and C3 must be rated at 12VDC or greater.

Output voltage ripple is affected by C3. Typically the larger the value of C3 the less the ripple for a given load current. The formula for P-P V_{RIPPLE} is given below:

$$V_{RIPPLE} = \{1/[2(f_{PUMP} \times C3)] + 2(ESR_{C3})\} (I_{OUT})$$

For a 10μF (0.5Ω ESR) capacitor for C3, $f_{PUMP} = 10kHz$ and $I_{OUT} = 10mA$ the peak-to-peak ripple voltage at the output will be less than 60mV. In most applications ($I_{OUT} < 10mA$) a 10-20μF capacitor and 1-5μF pump capacitors will suffice. Table 2 shows V_{RIPPLE} for different values of C3 (assume 1Ω ESR).

Table 1. R_{OUT} vs. C1, C2

C1, C2 (μF)	R_{OUT} (Ω)
0.05	4085
0.10	2084
0.47	510
1.00	285
3.30	145
5.00	125
10.00	105
22.00	94
100.00	87

Table 2. V_{RIPPLE} Peak- to-Peak vs. C3 ($I_{OUT} = 10mA$)

C3 (μF)	V_{RIPPLE} (mV)
0.50	1020
1.00	520
3.30	172
5.00	120
10.00	70
22.00	43
100.00	25

Paralleling Devices

Paralleling multiple TC682s reduces the output resistance of the converter. The effective output resistance is the output resistance of a single device divided by the number of devices. As illustrated in Figure 5, each requires separate pump capacitors C1 and C2, but all can share a single reservoir capacitor.

-5V Regulated Supply From A Single 3V Battery

Figure 6 shows a -5V power supply using one 3V battery. The TC682 provides -6V at V_{OUT} , which is regulated to -5V by the negative LDO. The input to the TC682 can vary from 3V to 5.5V without affecting regulation appreciably. A TC54 device is connected to the battery to detect undervoltage. This unit is set to detect at 2.7V. With higher input voltage, more current can be drawn from the outputs of the TC682. With 5V at V_{IN} , 10mA can be drawn from the regulated output. Assuming 150Ω source resistance for the converter, with $I_{L} = 10mA$, the charge pump will droop 1.5V.

INVERTING VOLTAGE DOUBLER

TC682

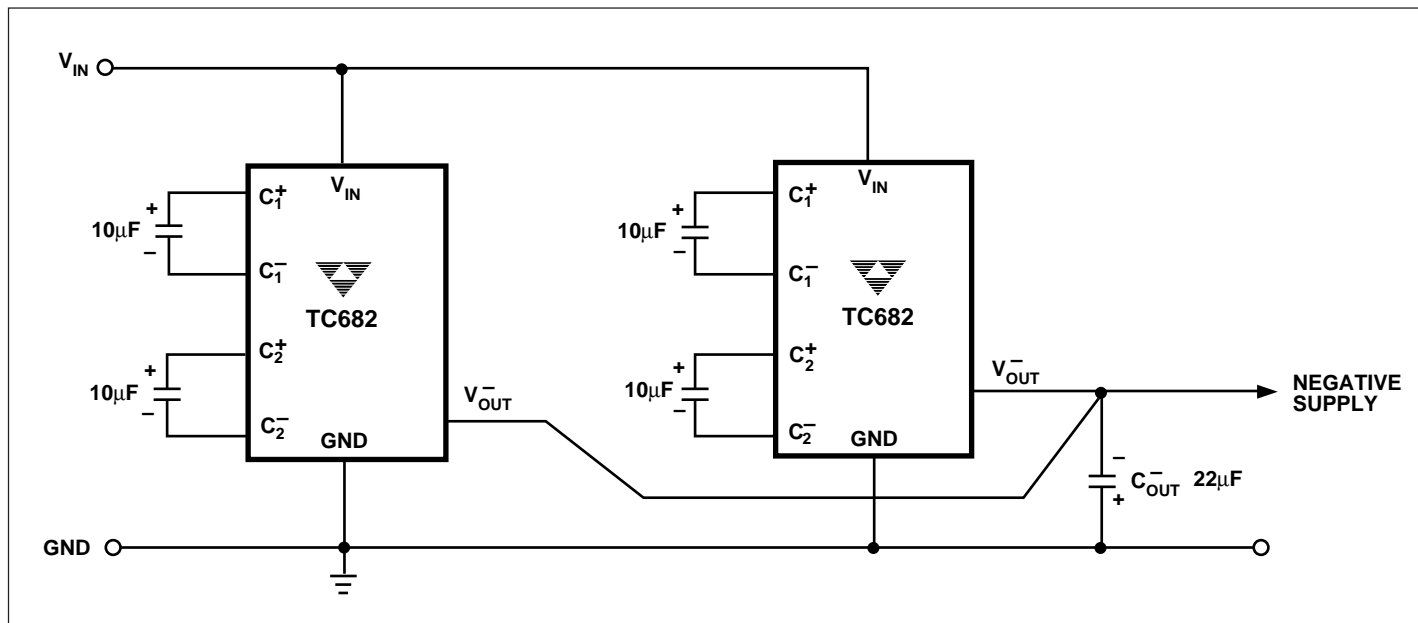

Figure 5. Paralleling TC682 for Lower Output Source Resistance

4

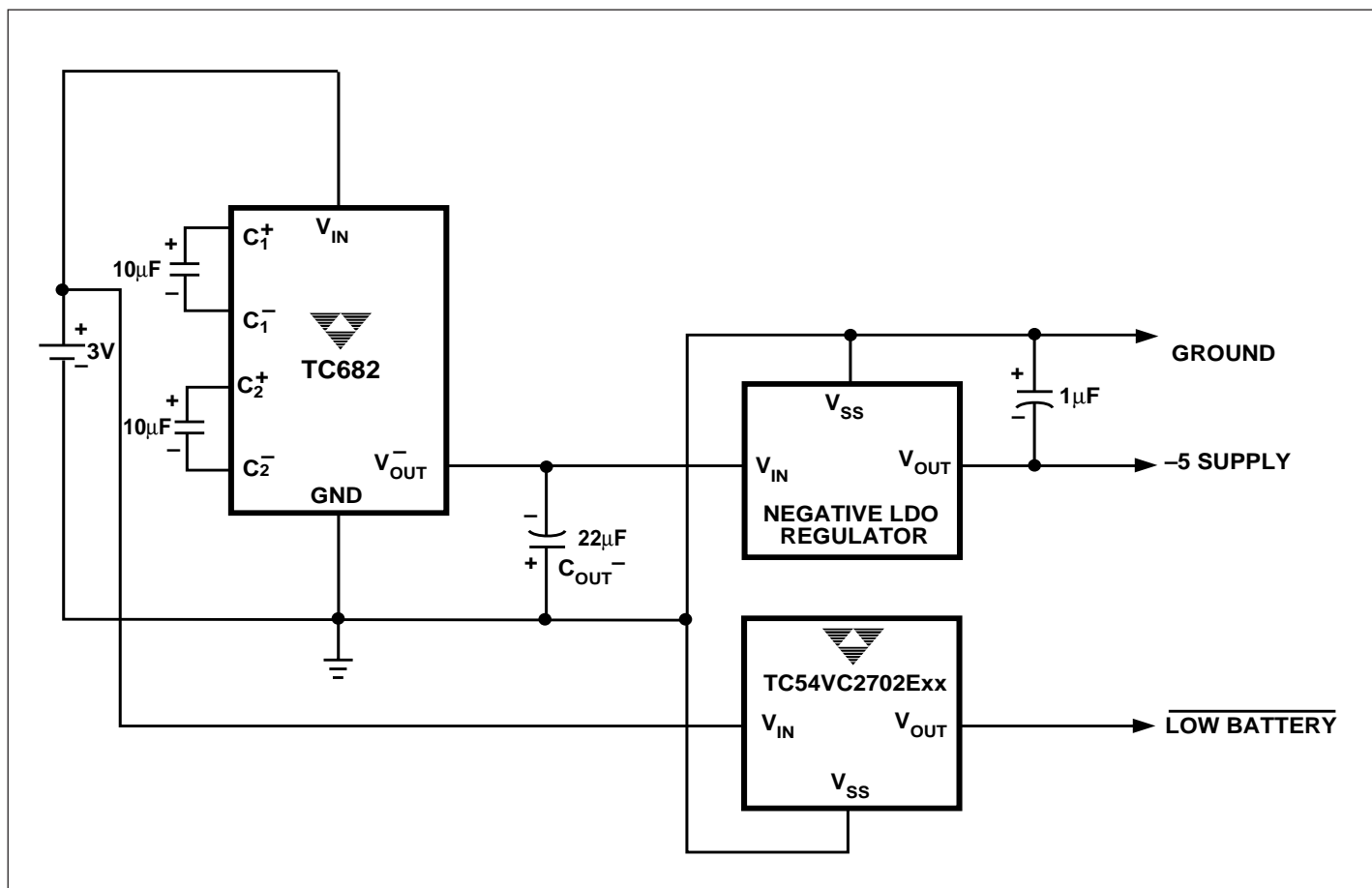

Figure 6. Negative Supply Derived from 3V Battery

INVERTING VOLTAGE DOUBLER

TC682

TYPICAL CHARACTERISTICS ($F_{OSC} = 12\text{kHz}$)

