

TOSHIBA CMOS DIGITAL INTEGRATED CIRCUIT SILICON MONOLITHIC

TC74AC257P, TC74AC257F, TC74AC257FN
TC74AC258P, TC74AC258F, TC74AC258FN

TC74AC257P/F/FN 2 - CHANNEL MULTIPLEXER (3 - STATE)
TC74AC258P/F/FN 2 - CHANNEL MULTIPLEXER (3 - STATE, INVERTING)

The TC74AC257 and TC74AC258 are advanced high speed CMOS MULTIPLEXERS fabricated with silicon gate and double-layer metal wiring C²MOS technology.

They achieve the high speed operation similar to equivalent Bipolar Schottky TTL while maintaining the CMOS low power dissipation.

Each is composed of four independent 2-channel multiplexers with common SELECT and OUTPUT ENABLE (\overline{OE}).

The TC74AC257 is a non-inverting multiplexer, while the TC74AC258 is an inverting.

If \overline{OE} is set low, the outputs are held in a high-impedance state. When SELECT is set low, "A" data inputs are enabled.

Conversely, when SELECT is high, "B" data inputs are enabled.

All inputs are equipped with protection circuits against static discharge or transient excess voltage.

FEATURES:

- High Speed..... $t_{pd} = 3.6ns$ (typ.) at $V_{CC} = 5V$
- Low Power Dissipation..... $I_{CC} = 8\mu A$ (Max.) at $T_a = 25^\circ C$
- High Noise Immunity..... $V_{NIH} = V_{NIL} = 28\% V_{CC}$ (Min.)
- Symmetrical Output Impedance... $|I_{OH}| = I_{OL} = 24mA$ (Min.)
 Capability of driving 50Ω transmission lines.
- Balanced Propagation Delays..... $t_{pLH} \approx t_{pHL}$
- Wide Operating Voltage Range..... $V_{CC} (opr) = 2V \sim 5.5V$
- Pin and Function Compatible with 74F257/258

(Note) The JEDEC SOP (FN) is not available in Japan.

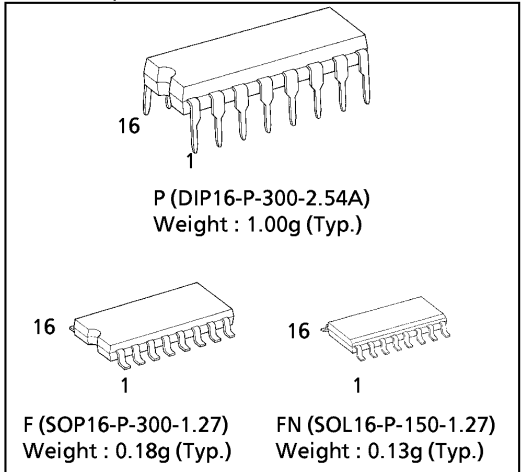

TRUTH TABLE

INPUTS				OUTPUTS	
\overline{OE}	SELECT	A	B	Y (257)	\overline{Y} (258)
H	X	X	X	Z	Z
L	L	L	X	L	H
L	L	H	X	H	L
L	H	X	L	L	H
L	H	X	H	H	L

X : Don't Care
 Z : High Impedance

PIN ASSIGNMENT

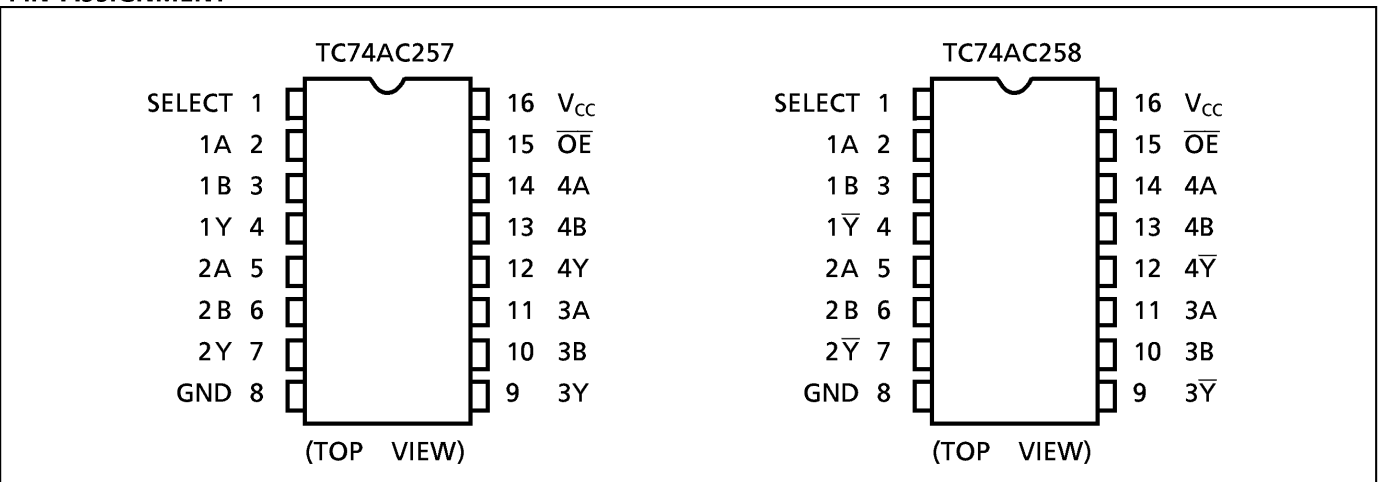

IEC LOGIC SYMBOL

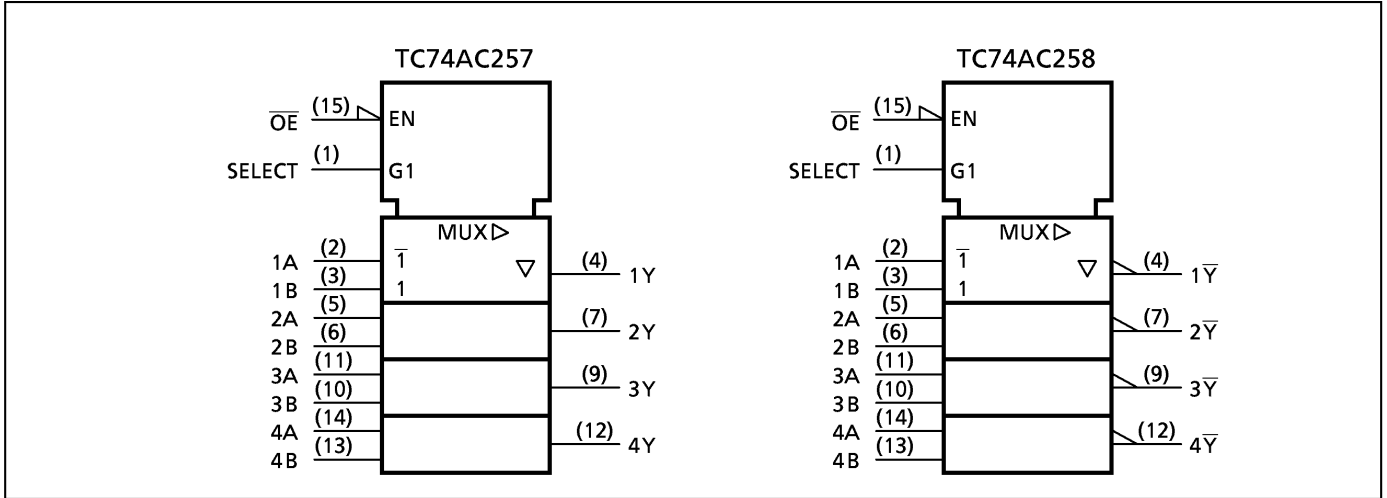

SYSTEM DIAGRAM

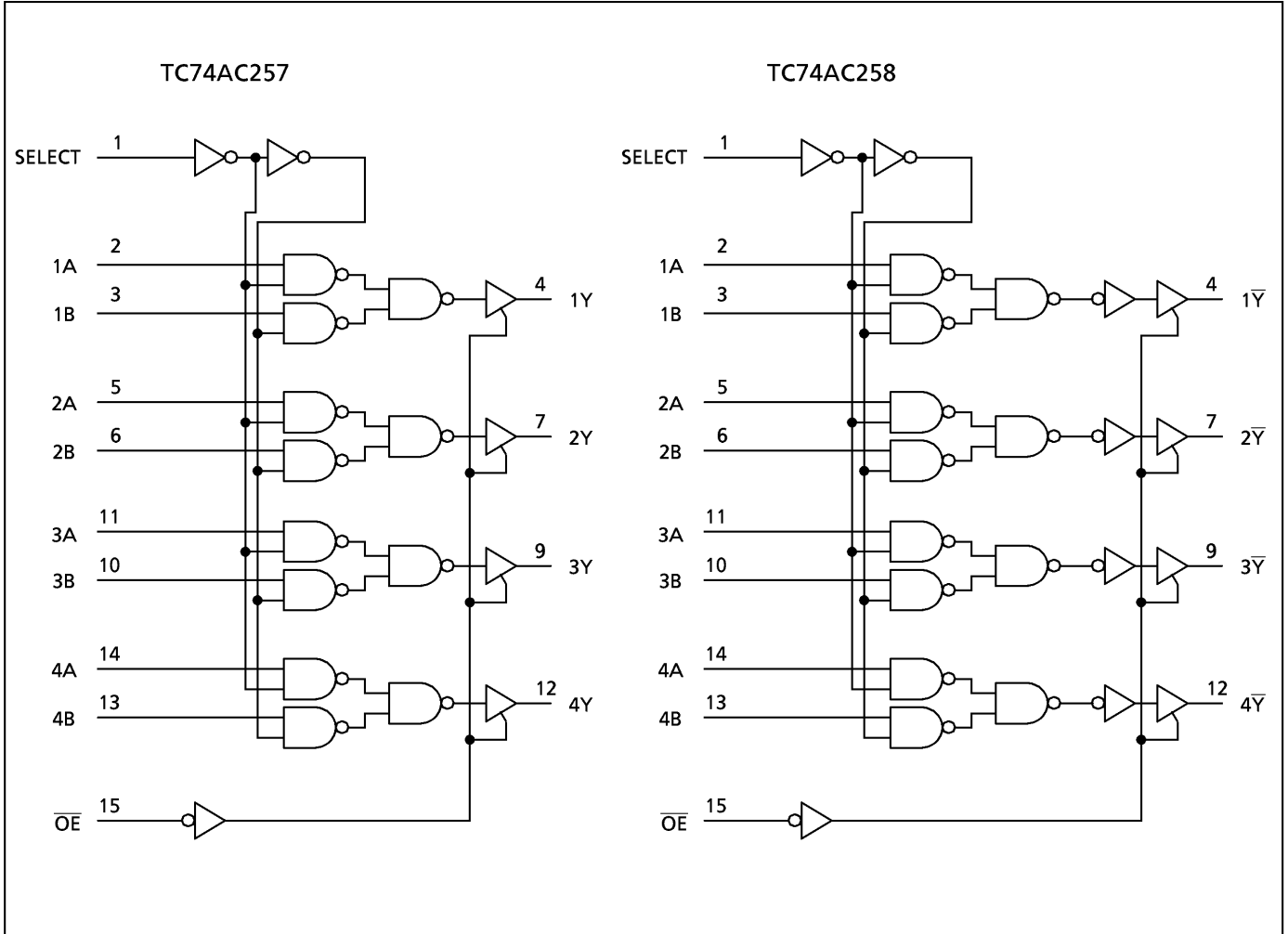

ABSOLUTE MAXIMUM RATINGS

PARAMETER	SYMBOL	VALUE	UNIT
Supply Voltage Range	V_{CC}	-0.5~7.0	V
DC Input Voltage	V_{IN}	-0.5~ $V_{CC} + 0.5$	V
DC Output Voltage	V_{OUT}	-0.5~ $V_{CC} + 0.5$	V
Input Diode Current	I_{IK}	± 20	mA
Output Diode Current	I_{OK}	± 50	mA
DC Output Current	I_{OUT}	± 50	mA
DC V_{CC} /Ground Current	I_{CC}	± 100	mA
Power Dissipation	P_D	500 (DIP)* / 180 (SOP)	mW
Storage Temperature	T_{stg}	-65~150	°C

*500mW in the range of $T_a = -40^{\circ}\text{C} \sim 65^{\circ}\text{C}$. From $T_a = 65^{\circ}\text{C}$ to 85°C a derating factor of $-10\text{mW}/^{\circ}\text{C}$ should be applied up to 300mW.

RECOMMENDED OPERATING CONDITIONS

PARAMETER	SYMBOL	VALUE	UNIT
Supply Voltage	V_{CC}	2.0~5.5	V
Input Voltage	V_{IN}	0~ V_{CC}	V
Output Voltage	V_{OUT}	0~ V_{CC}	V
Operating Temperature	T_{opr}	-40~85	°C
Input Rise and Fall Time	dt / dV	0~100 ($V_{CC} = 3.3 \pm 0.3\text{V}$) 0~20 ($V_{CC} = 5 \pm 0.5\text{V}$)	ns / V

DC ELECTRICAL CHARACTERISTICS

PARAMETER	SYMBOL	TEST CONDITION	V_{CC} (V)	$T_a = 25^{\circ}\text{C}$			$T_a = -40 \sim 85^{\circ}\text{C}$		UNIT	
				MIN.	TYP.	MAX.	MIN.	MAX.		
High - Level Input Voltage	V_{IH}		2.0 3.0 5.5	1.50 2.10 3.85	— — —	— — —	1.50 2.10 3.85	— — —	V	
Low - Level Input Voltage	V_{IL}		2.0 3.0 5.5	— — —	— — —	0.50 0.90 1.65	— — —	0.50 0.90 1.65	— — —	V
High - Level Output Voltage	V_{OH}	$V_{IN} = V_{IH}$ or V_{IL}	$I_{OH} = -50\mu\text{A}$	2.0 3.0 4.5	1.9 2.9 4.4	2.0 3.0 4.5	— — —	1.9 2.9 4.4	— — —	V
			$I_{OH} = -4\text{mA}$	3.0	2.58	—	—	2.48	—	
			$I_{OH} = -24\text{mA}$ $I_{OH} = -75\text{mA}^*$	4.5 5.5	3.94 —	— —	— —	3.80 3.85	— —	
Low - Level Output Voltage	V_{OL}	$V_{IN} = V_{IH}$ or V_{IL}	$I_{OL} = 50\mu\text{A}$	2.0 3.0 4.5	— — —	0.0 0.0 0.0	0.1 0.1 0.1	— — —	0.1 0.1 0.1	V
			$I_{OL} = 12\text{mA}$	3.0	—	—	0.36	—	0.44	
			$I_{OL} = 24\text{mA}$ $I_{OL} = 75\text{mA}^*$	4.5 5.5	— —	— —	0.36 —	— —	0.44 1.65	
3 - State Output Off - State Current	I_{OZ}	$V_{IN} = V_{IH}$ or V_{IL} $V_{OUT} = V_{CC}$ or GND	5.5	—	—	± 0.5	—	± 5.0	μA	
Input Leakage Current	I_{IN}	$V_{IN} = V_{CC}$ or GND	5.5	—	—	± 0.1	—	± 1.0		
Quiescent Supply Current	I_{CC}	$V_{IN} = V_{CC}$ or GND	5.5	—	—	8.0	—	80.0		

* : This spec indicates the capability of driving 50Ω transmission lines.
One output should be tested at a time for a 10ms maximum duration.

AC ELECTRICAL CHARACTERISTICS ($C_L = 50\text{pF}$, $R_L = 500\Omega$, Input $t_r = t_f = 3\text{ns}$)

PARAMETER	SYMBOL	TEST CONDITION	Ta = 25°C			Ta = -40~85°C		UNIT	
			V _{CC} (V)	MIN.	TYP.	MAX.	MIN.		MAX.
Propagation Delay Time (A, B-Y, \bar{Y})	t_{pLH} t_{pHL}		3.3 ± 0.3	—	7.0	14.3	1.0	16.3	ns
			5.0 ± 0.5	—	4.7	7.5	1.0	8.5	
Propagation Delay Time (SELECT-Y, \bar{Y})	t_{pLH} t_{pHL}		3.3 ± 0.3	—	8.6	17.2	1.0	19.6	
			5.0 ± 0.5	—	5.5	9.1	1.0	10.4	
Output Enable Time	t_{pZL} t_{pHZ}		3.3 ± 0.3	—	7.3	14.0	1.0	16.0	
			5.0 ± 0.5	—	5.0	7.9	1.0	9.0	
Output Disable Time	t_{pLZ} t_{pHZ}		3.3 ± 0.3	—	5.6	9.6	1.0	11.0	
			5.0 ± 0.5	—	5.1	7.9	1.0	9.0	
Input Capacitance	C _{IN}		—	5	10	—	10	pF	
Output Capacitance	C _{OUT}		—	10	—	—	—		
Power Dissipation Capacitance	C _{PD} (1)		—	28	—	—	—		

Note (1) C_{PD} is defined as the value of the internal equivalent capacitance which is calculated from the operating current consumption without load.

Average operating current can be obtained by the equation :

$$I_{CC}(\text{opr.}) = C_{PD} \cdot V_{CC} \cdot f_{IN} + I_{CC}/4 \text{ (per bit)}$$

DIP 16PIN PACKAGE DIMENSIONS (DIP16-P-300-2.54A)

Unit in mm



Weight : 1.00g (Typ.)

SOP 16PIN (200mil BODY) PACKAGE DIMENSIONS (SOP16-P-300-1.27)

Unit in mm



Weight : 0.18g (Typ.)

SOP 16PIN (150mil BODY) PACKAGE DIMENSIONS (SOL16-P-150 -1.27)

Unit in mm

(Note) This package is not available in Japan.

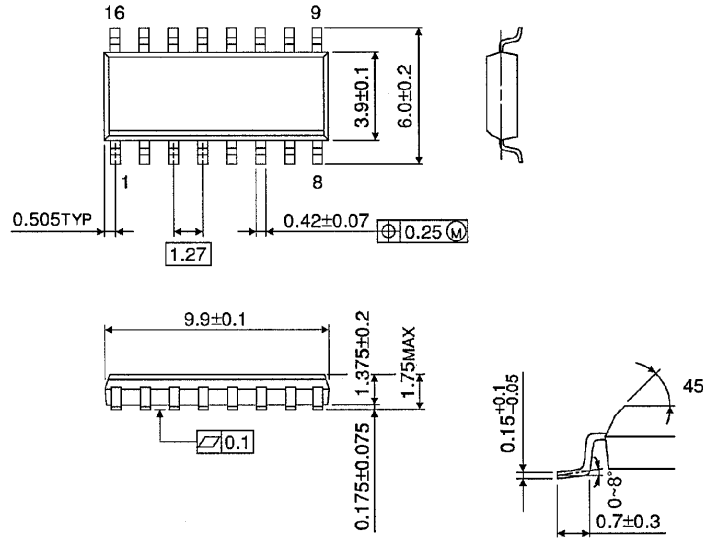

Weight : 0.13g (Typ.)

RESTRICTIONS ON PRODUCT USE

000707EBA

- TOSHIBA is continually working to improve the quality and reliability of its products. Nevertheless, semiconductor devices in general can malfunction or fail due to their inherent electrical sensitivity and vulnerability to physical stress. It is the responsibility of the buyer, when utilizing TOSHIBA products, to comply with the standards of safety in making a safe design for the entire system, and to avoid situations in which a malfunction or failure of such TOSHIBA products could cause loss of human life, bodily injury or damage to property. In developing your designs, please ensure that TOSHIBA products are used within specified operating ranges as set forth in the most recent TOSHIBA products specifications. Also, please keep in mind the precautions and conditions set forth in the "Handling Guide for Semiconductor Devices," or "TOSHIBA Semiconductor Reliability Handbook" etc..
- The TOSHIBA products listed in this document are intended for usage in general electronics applications (computer, personal equipment, office equipment, measuring equipment, industrial robotics, domestic appliances, etc.). These TOSHIBA products are neither intended nor warranted for usage in equipment that requires extraordinarily high quality and/or reliability or a malfunction or failure of which may cause loss of human life or bodily injury ("Unintended Usage"). Unintended Usage include atomic energy control instruments, airplane or spaceship instruments, transportation instruments, traffic signal instruments, combustion control instruments, medical instruments, all types of safety devices, etc.. Unintended Usage of TOSHIBA products listed in this document shall be made at the customer's own risk.
- The products described in this document are subject to the foreign exchange and foreign trade laws.
- The information contained herein is presented only as a guide for the applications of our products. No responsibility is assumed by TOSHIBA CORPORATION for any infringements of intellectual property or other rights of the third parties which may result from its use. No license is granted by implication or otherwise under any intellectual property or other rights of TOSHIBA CORPORATION or others.
- The information contained herein is subject to change without notice.

Copyright Each Manufacturing Company.

All Datasheets cannot be modified without permission.

This datasheet has been download from :

www.AllDataSheet.com

100% Free DataSheet Search Site.

Free Download.

No Register.

Fast Search System.

www.AllDataSheet.com