

**TC74AC573P, TC74AC573F, TC74AC573FW, TC74AC573FT**

**OCTAL D - TYPE LATCH WITH 3 - STATE OUTPUT**

The TC74AC573 is an advanced high speed CMOS OCTAL LATCH fabricated with silicon gate and double - layer metal wiring C<sup>2</sup>MOS technology.

It achieves the high speed operation similar to equivalent Bipolar Schottky TTL while maintaining the CMOS low power dissipation.

These 8 - bit D - type latches are controlled by a latch enable input (LE) and a output enable input ( $\overline{OE}$ ).

When the  $\overline{OE}$  input is high, the eight outputs are in a high impedance state.

All inputs are equipped with protection circuits against static discharge or transient excess voltage.

**FEATURES :**

- High Speed..... $t_{pd} = 6.0ns(typ.)$  at  $V_{CC} = 5V$
- Low Power Dissipation..... $I_{CC} = 8\mu A(Max.)$  at  $T_a = 25^\circ C$
- High Noise Immunity..... $V_{NIH} = V_{NIL} = 28\% V_{CC} (Min.)$
- Symmetrical Output Impedance...  $|I_{OH}| = I_{OL} = 24mA(Min.)$   
 Capability of driving  $50\Omega$  transmission lines.
- Balanced Propagation Delays.....  $t_{pLH} \approx t_{pHL}$
- Wide Operating Voltage Range...  $V_{CC} (opr) = 2V \sim 5.5V$
- Pin and Function Compatible with 74F573

**TRUTH TABLE**

INPUTS			OUTPUTS
$\overline{OE}$	LE	D	Q
H	X	X	Z
L	L	X	$Q_n$
L	H	L	L
L	H	H	H

X : Don't Care  
 Z : High Impedance  
 $Q_n$  : Q outputs are latched at the time when the LE input is taken to a low logic level.

(Note) The JEDEC SOP (FW) is not available in Japan.

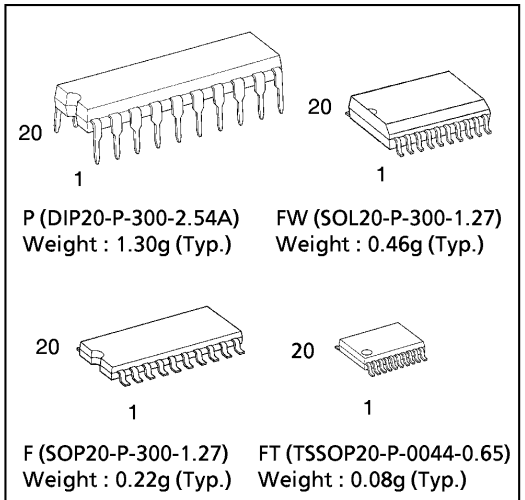

**PIN ASSIGNMENT**

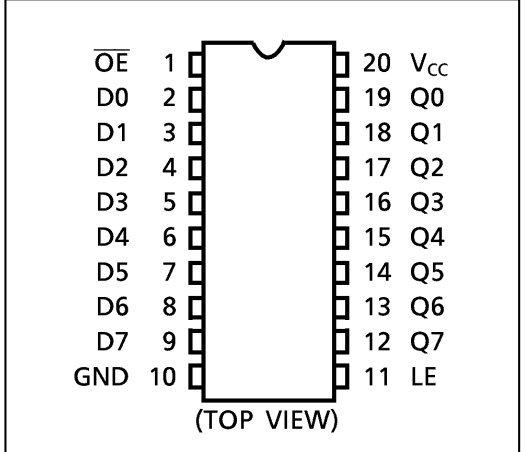

**IEC LOGIC SYMBOL**

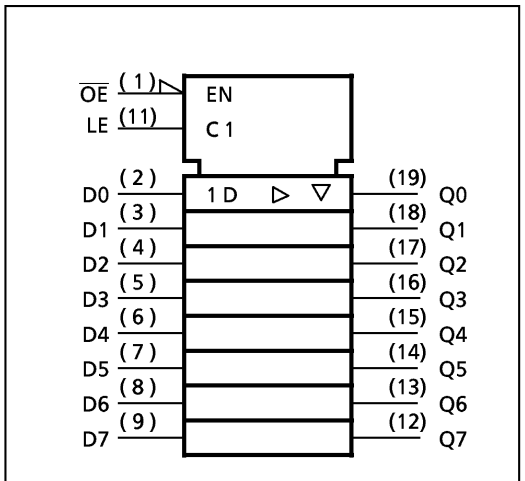

**SYSTEM DIAGRAM**

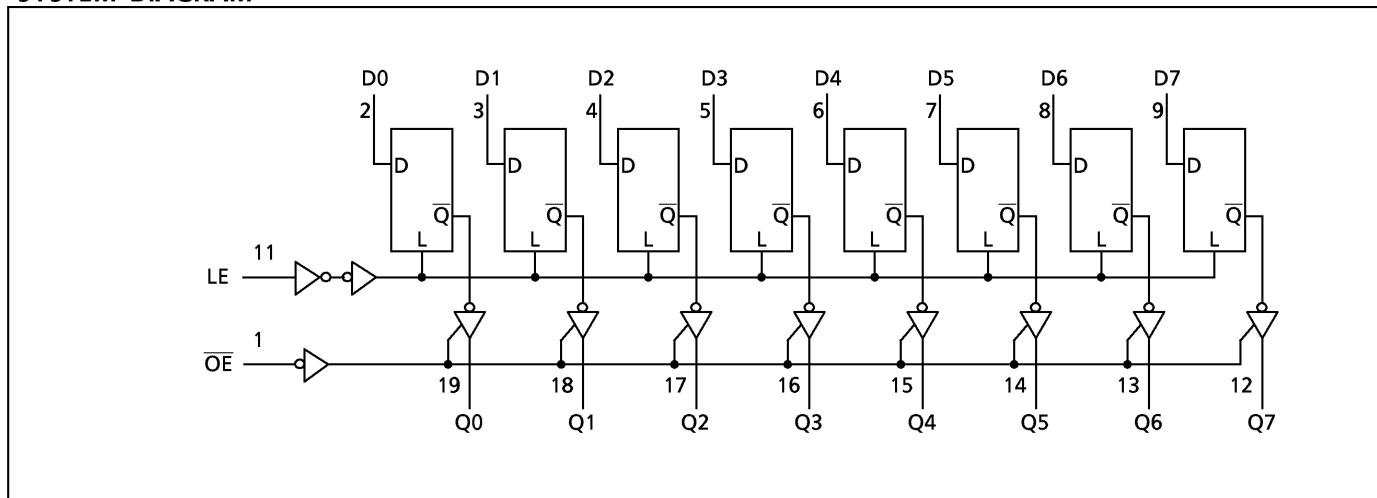

**ABSOLUTE MAXIMUM RATINGS**

PARAMETER	SYMBOL	VALUE	UNIT
Supply Voltage Range	$V_{CC}$	-0.5~7.0	V
DC Input Voltage	$V_{IN}$	-0.5~ $V_{CC} + 0.5$	V
DC Output Voltage	$V_{OUT}$	-0.5~ $V_{CC} + 0.5$	V
Input Diode Current	$I_{IK}$	$\pm 20$	mA
Output Diode Current	$I_{OK}$	$\pm 50$	mA
DC Output Current	$I_{OUT}$	$\pm 50$	mA
DC $V_{CC}$ /Ground Current	$I_{CC}$	$\pm 200$	mA
Power Dissipation	$P_D$	500 (DIP)* / 180 (SOP/TSSOP)	mW
Storage Temperature	$T_{stg}$	-65~150	$^{\circ}C$

\*500mW in the range of  $T_a = -40^{\circ}C \sim 65^{\circ}C$ . From  $T_a = 65^{\circ}C$  to  $85^{\circ}C$  a derating factor of  $-10mW/^{\circ}C$  should be applied up to 300mW.

**RECOMMENDED OPERATING CONDITIONS**

PARAMETER	SYMBOL	VALUE	UNIT
Supply Voltage	$V_{CC}$	2.0~5.5	V
Input Voltage	$V_{IN}$	0~ $V_{CC}$	V
Output Voltage	$V_{OUT}$	0~ $V_{CC}$	V
Operating Temperature	$T_{opr}$	-40~85	$^{\circ}C$
Input Rise and Fall Time	dt / dV	0~100 ( $V_{CC} = 3.3 \pm 0.3V$ ) 0~20 ( $V_{CC} = 5 \pm 0.5V$ )	ns / V

## DC ELECTRICAL CHARACTERISTICS

PARAMETER	SYMBOL	TEST CONDITION	V <sub>CC</sub> (V)	Ta = 25°C			Ta = -40~85°C		UNIT				
				MIN.	TYP.	MAX.	MIN.	MAX.					
High - Level Input Voltage	V <sub>IH</sub>		2.0 3.0 5.5	1.50 2.10 3.85	— — —	— — —	1.50 2.10 3.85	— — —	V				
Low - Level Input Voltage	V <sub>IL</sub>		2.0 3.0 5.5	— — —	— — —	0.50 0.90 1.65	— — —	0.50 0.90 1.65	V				
High - Level Output Voltage	V <sub>OH</sub>	V <sub>IN</sub> = V <sub>IH</sub> or V <sub>IL</sub>	I <sub>OH</sub> = -50μA	2.0	1.9	2.0	—	1.9	—	V			
				3.0	2.9	3.0	—	2.9	—				
				4.5	4.4	4.5	—	4.4	—				
Low - Level Output Voltage	V <sub>OL</sub>	V <sub>IN</sub> = V <sub>IH</sub> or V <sub>IL</sub>	I <sub>OL</sub> = 50μA	2.0	—	0.0	0.1	—	0.1	V			
				3.0	—	0.0	0.1	—	0.1				
				4.5	—	0.0	0.1	—	0.1				
3 - State Output Off - State Current	I <sub>OZ</sub>	V <sub>IN</sub> = V <sub>IH</sub> or V <sub>IL</sub> V <sub>OUT</sub> = V <sub>CC</sub> or GND	5.5	—	—	±0.5	—	±5.0	μA				
				Input Leakage Current	I <sub>IN</sub>	V <sub>IN</sub> = V <sub>CC</sub> or GND	5.5	—		—	±0.1	—	±1.0
				Quiescent Supply Current	I <sub>CC</sub>	V <sub>IN</sub> = V <sub>CC</sub> or GND	5.5	—		—	8.0	—	80.0

\* : This spec indicates the capability of driving 50Ω transmission lines.  
One output should be tested at a time for a 10ms maximum duration.

TIMING REQUIREMENTS (Input t<sub>r</sub> = t<sub>f</sub> = 3ns)

PARAMETER	SYMBOL	TEST CONDITION	V <sub>CC</sub> (V)	Ta = 25°C	Ta = -40~85°C	UNIT
				LIMIT	LIMIT	
Minimum Pulse Width (LE)	t <sub>W</sub> (H)		3.3 ± 0.3	7.0	7.0	ns
			5.0 ± 0.5	5.0	5.0	
Minimum Set - up Time	t <sub>s</sub>		3.3 ± 0.3	7.0	7.0	
			5.0 ± 0.5	4.0	4.0	
Minimum Hold Time	t <sub>h</sub>		3.3 ± 0.3	1.0	1.0	
			5.0 ± 0.5	1.0	1.0	

AC ELECTRICAL CHARACTERISTICS ( $C_L = 50\text{pF}$ ,  $R_L = 500\Omega$ , Input  $t_r = t_f = 3\text{ns}$ )

PARAMETER	SYMBOL	TEST CONDITION	Ta = 25°C			Ta = -40~85°C		UNIT	
			V <sub>CC</sub> (V)	MIN.	TYP.	MAX.	MIN.		MAX.
Propagation Delay Time (LE-Q)	t <sub>pLH</sub> t <sub>pHL</sub>		3.3 ± 0.3	—	9.4	15.4	1.0	17.6	ns
			5.0 ± 0.5	—	6.6	9.9	1.0	11.3	
Propagation Delay Time (Dn-Q)	t <sub>pLH</sub> t <sub>pHL</sub>		3.3 ± 0.3	—	9.4	16.0	1.0	18.2	
			5.0 ± 0.5	—	6.2	8.9	1.0	10.2	
Output Enable Time	t <sub>pZL</sub> t <sub>pZH</sub>		3.3 ± 0.3	—	9.0	15.2	1.0	17.3	
			5.0 ± 0.5	—	6.3	9.2	1.0	10.5	
Output Disable Time	t <sub>pLZ</sub> t <sub>pHZ</sub>		3.3 ± 0.3	—	7.0	12.3	1.0	14.0	
			5.0 ± 0.5	—	6.0	8.8	1.0	10.0	
Input Capacitance	C <sub>IN</sub>		—	5	10	—	10	pF	
Output Capacitance	C <sub>OUT</sub>		—	10	—	—	—		
Power Dissipation Capacitance	C <sub>PD</sub> (1)		—	32	—	—	—		

Note (1) C<sub>PD</sub> is defined as the value of the internal equivalent capacitance which is calculated from the operating current consumption without load.

Average operating current can be obtained by the equation :

$$I_{CC}(\text{opr.}) = C_{PD} \cdot V_{CC} \cdot f_{IN} + I_{CC} / 8 \text{ (per Latch)}$$

And the total C<sub>PD</sub> when n pcs. of Latch operate can be gained by the following equation :

$$C_{PD}(\text{total}) = 21 + 11 \cdot n$$

**DIP 20PIN PACKAGE DIMENSIONS (DIP20-P-300-2.54A)**

Unit in mm

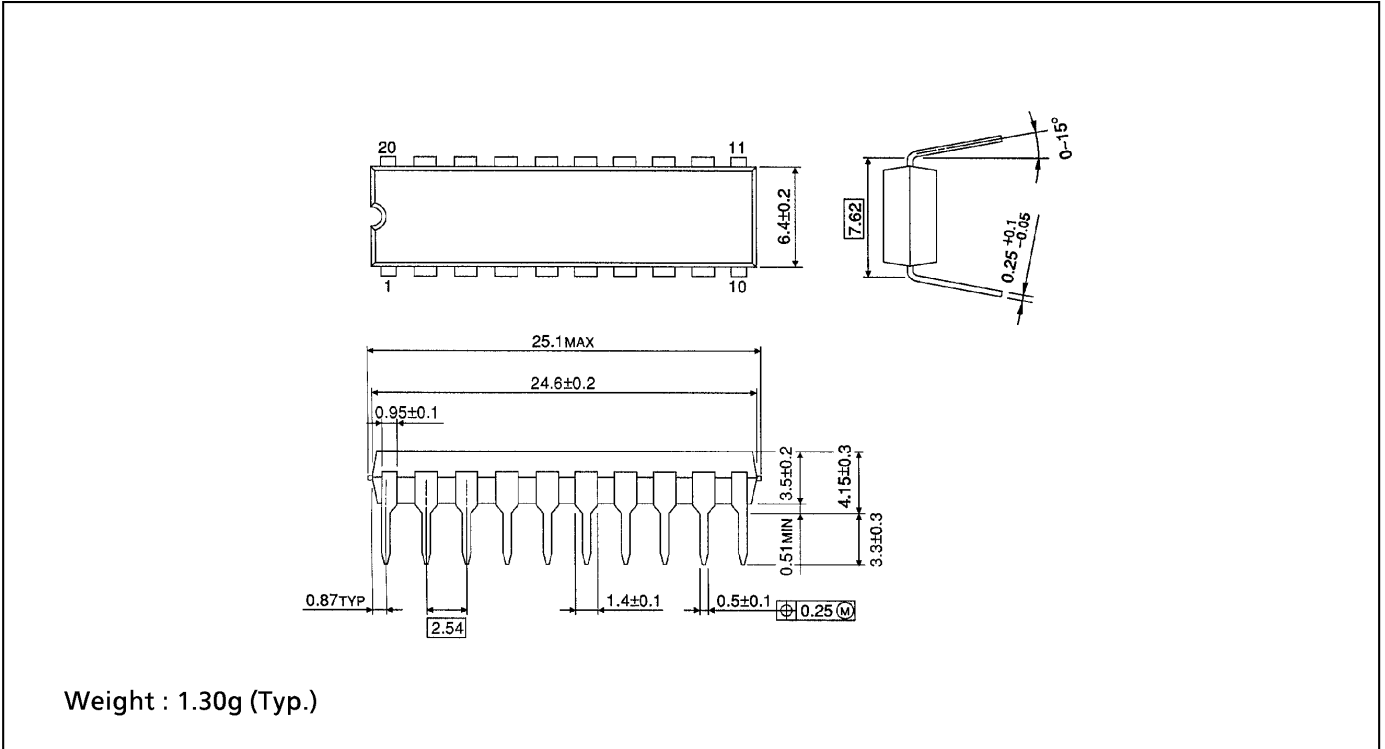

**SOP 20PIN (200mil BODY) PACKAGE DIMENSIONS (SOP20-P-300-1.27)**

Unit in mm

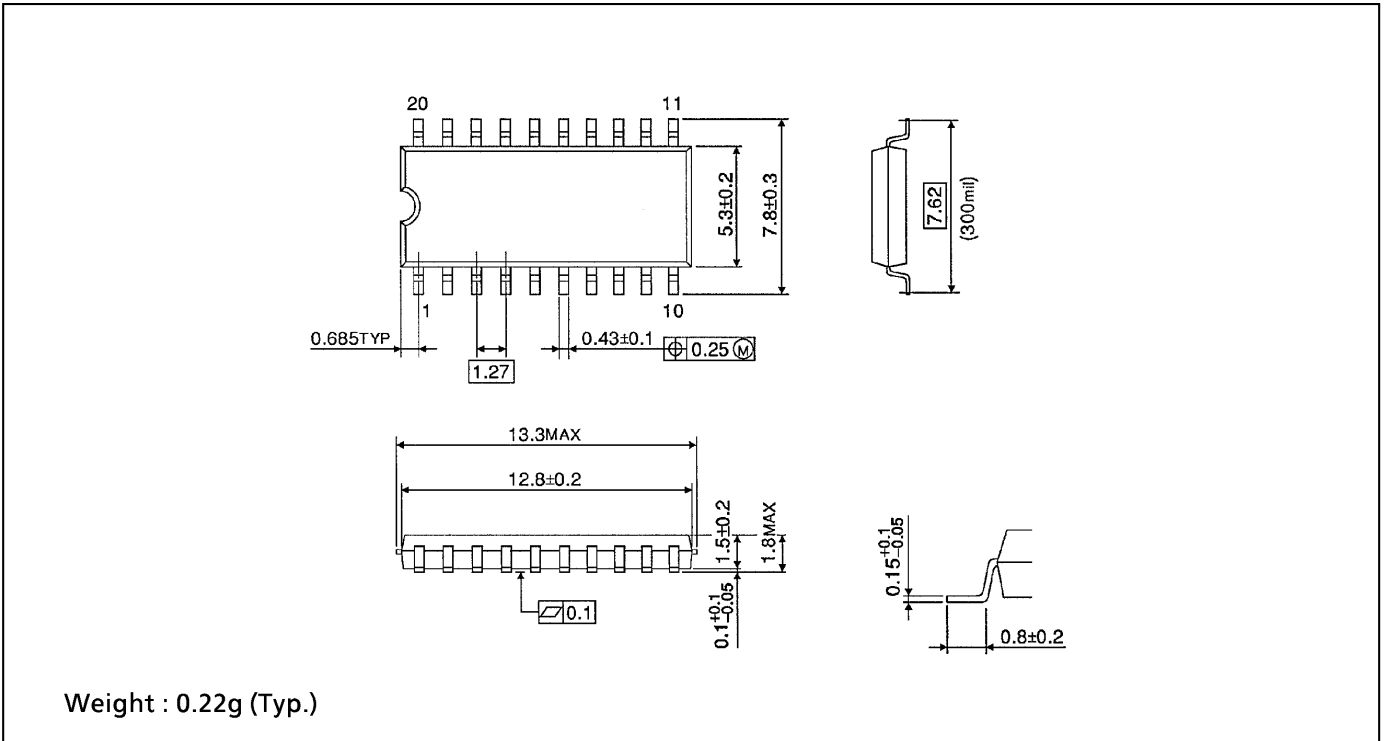

**SOP 20PIN (300mil BODY) PACKAGE DIMENSIONS (SOL20-P-300-1.27)**

Unit in mm

(Note) This package is not available in Japan.

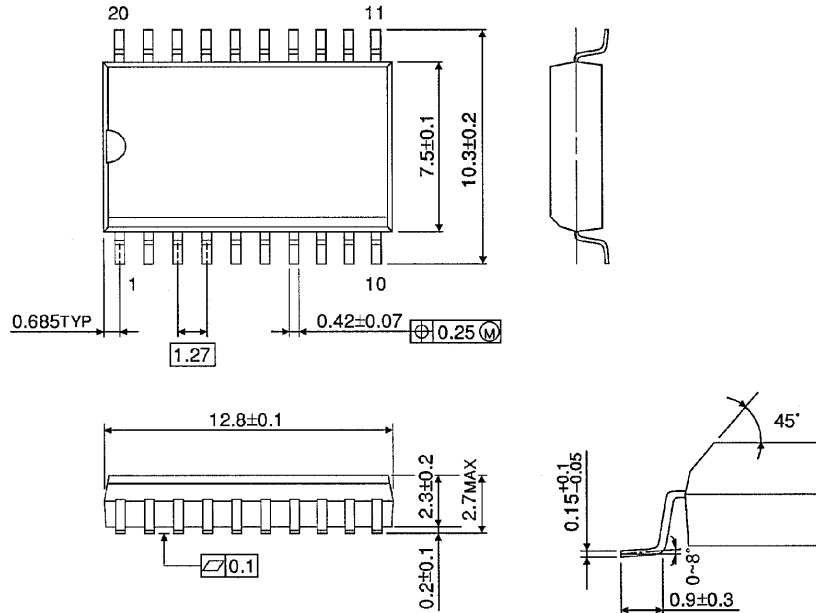

Weight : 0.46g (Typ.)

**TSSOP 20PIN PACKAGE DIMENSIONS (TSSOP20-P-0044-0.65)**

Unit in mm

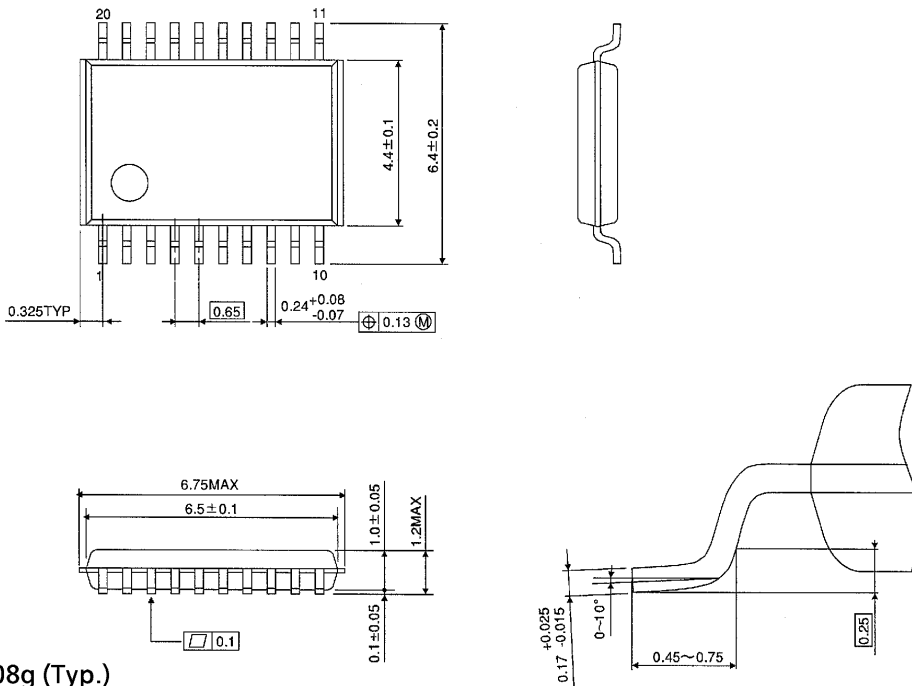

Weight : 0.08g (Typ.)

**RESTRICTIONS ON PRODUCT USE**

000707EBA

- TOSHIBA is continually working to improve the quality and reliability of its products. Nevertheless, semiconductor devices in general can malfunction or fail due to their inherent electrical sensitivity and vulnerability to physical stress. It is the responsibility of the buyer, when utilizing TOSHIBA products, to comply with the standards of safety in making a safe design for the entire system, and to avoid situations in which a malfunction or failure of such TOSHIBA products could cause loss of human life, bodily injury or damage to property. In developing your designs, please ensure that TOSHIBA products are used within specified operating ranges as set forth in the most recent TOSHIBA products specifications. Also, please keep in mind the precautions and conditions set forth in the "Handling Guide for Semiconductor Devices," or "TOSHIBA Semiconductor Reliability Handbook" etc..
- The TOSHIBA products listed in this document are intended for usage in general electronics applications (computer, personal equipment, office equipment, measuring equipment, industrial robotics, domestic appliances, etc.). These TOSHIBA products are neither intended nor warranted for usage in equipment that requires extraordinarily high quality and/or reliability or a malfunction or failure of which may cause loss of human life or bodily injury ("Unintended Usage"). Unintended Usage include atomic energy control instruments, airplane or spaceship instruments, transportation instruments, traffic signal instruments, combustion control instruments, medical instruments, all types of safety devices, etc.. Unintended Usage of TOSHIBA products listed in this document shall be made at the customer's own risk.
- The products described in this document are subject to the foreign exchange and foreign trade laws.
- The information contained herein is presented only as a guide for the applications of our products. No responsibility is assumed by TOSHIBA CORPORATION for any infringements of intellectual property or other rights of the third parties which may result from its use. No license is granted by implication or otherwise under any intellectual property or other rights of TOSHIBA CORPORATION or others.
- The information contained herein is subject to change without notice.

Copyright Each Manufacturing Company.

All Datasheets cannot be modified without permission.

This datasheet has been download from :

[www.AllDataSheet.com](http://www.AllDataSheet.com)

100% Free DataSheet Search Site.

Free Download.

No Register.

Fast Search System.

[www.AllDataSheet.com](http://www.AllDataSheet.com)