

TOSHIBA CMOS Digital Integrated Circuit Silicon Monolithic

TC83220-0009

TC83220-0009: Single-Chip CMOS LSI for FL (fluorescent) Calculator with Printers

The TOSHIBA printing/display calculator circuit TC83220-0009 is 10/12-digit calculator on a single-chip CMOS LSI.

TC83220-0009 can drive the printing machine (M-42TV/42V; EPSON) with magnet driver circuit, and can drive the fluorescent display tube with DC-DC converter. It contains a 4 K-word ROM, a 256 × 4-bit RAM.

Features

Operational Features

- Print: 12/14 digits of data.
(including decimal point and minus signs.) 2 digits of operational symbol.
3 digits of commas.
- Display: 10/12 digits of data. (including punctuation in each digit.)
1 digit of floating minus sign, memory load, error symbol.
3 digits of commas.
- Decimal output: Decimal set lock key controls output format.
Fixed decimal setting ("0", "1", "2", "3", "4", "6"), full floating decimal, and ADD mode.
- Key input buffer: 8 stages
- Function: 4 basic arithmetic function (+, -, ×, ÷).
Repeat addition and subtraction.
Automatic constants in multiplication, division, percent calculation, calculations.
Automatic percent add-on and percent discount calculations.
Memory calculation.
Automatic accumulating calculation.
Gross margin profit calculation.
Delta percent calculation.
Two-key rollover.
- Item counter: 0~999 count up or -999~0~999 count up/down by depressing of $\boxed{+}$, $\boxed{-}$, $\boxed{+/-}$, $\boxed{=}$ key.
- Punctuation: Commas for thousands on display.
- Kinds of touch key:

$\boxed{0} \sim \boxed{9}$, $\boxed{\cdot}$, $\boxed{00}$, $\boxed{000}$, \boxed{C} , \boxed{CE} , $\boxed{C/CE}$, $\boxed{+/-}$, $\boxed{\#/P}$, $\boxed{\text{Feed}}$,
 $\boxed{+}$, $\boxed{-}$, $\boxed{\diamond}$, $\boxed{*}$, $\boxed{\times}$, $\boxed{\div}$, $\boxed{=}$, $\boxed{\%}$, $\boxed{MU/D}$, $\boxed{M+}$, $\boxed{M-}$, $\boxed{M\diamond}$,
 $\boxed{M*}$, $\boxed{\Delta\%}$, $\boxed{M\diamond*}$, \boxed{IC} , $\boxed{\rightarrow}$, \boxed{ON} , \boxed{OFF} , $\boxed{+/-}$, $\boxed{=}$, $\boxed{=}$, \boxed{GT}

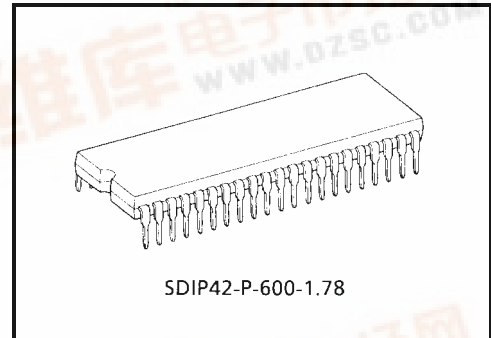

Weight: 4.12 g (typ.)

- Kinds of lock key: “PRINT” printing mode selectable switch.
 “Σ” summation mode selectable switch.
 “5/4” “CUT” “UP” rounding switch.
 Fixed point mode selectable switch.
 “0”, “1”, “2”, “3”, “4”, “6”, “F”, “AM”.
 “IC+”, “IC±” item counter mode selectable switch.
 “GT” grand total memory selectable switch.
- Duty of display: Duty = 1/14.9
- Leading zero suppression
- Trailing zero suppression

Electrical Features

- P-MOS output buffer with pull down resistor for direct driving of fluorescent display tube.
- Oscillator/clock generator internal to chip.
- Key board encoding internal to chip.
- Dual in line package.

Protection

- (1) Double depression of keys will be scan of fast key.
- (2) In the overflow condition, all key except “C”, “CE”, “Feed”, “ON”, “OFF”, “→” key are inoperative.
- (3) Key bouncing protection (at 4 MHz clock)
 Key read in: 15 ms
 Key off: 40 ms

Function Select

- (1) “TMR” selectable with auto power off mode
 OFF..... Auto power off mode
- (2) “10/12” selectable with auto power off mode
 ON..... 10 digit calculated
 OFF..... 12 digit calculated
- (3) “B/R” Selectable with printer heads
 ON..... M-42V (1 color)
 OFF..... M-42TV (2 color)

Speed of Calculation (at 4 MHz clock)

- | | | |
|----------------------------|----------------------|----------|
| (1) Addition | 1 + 1 + | 31.2 ms |
| (2) Multiplication | 1 × 999999999999 = | 26.8 ms |
| (3) Division | 999999999999 ÷ 1 = | 100.6 ms |
| (4) Memory calculation | 999999999999 ÷ 1 M + | 108.8 ms |
| (5) Percentage calculation | 1 × 999999999999% | 35.2 ms |

“CNT (R83)” Function

- | | |
|-----------|--|
| Operation | On display.....Open |
| | Printing..... Open |
| | Off (hold) mode..... V _{DD} Level |

Pin Assignment (top view)

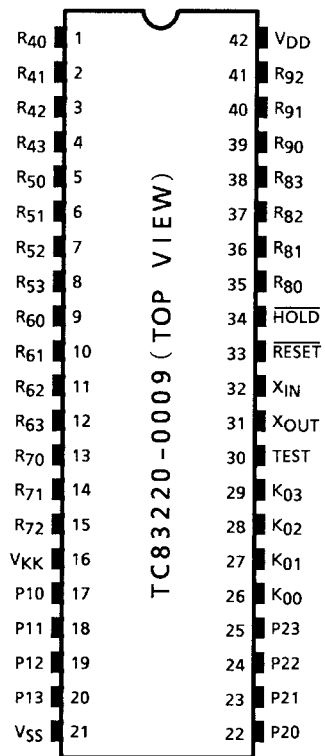

System Diagram

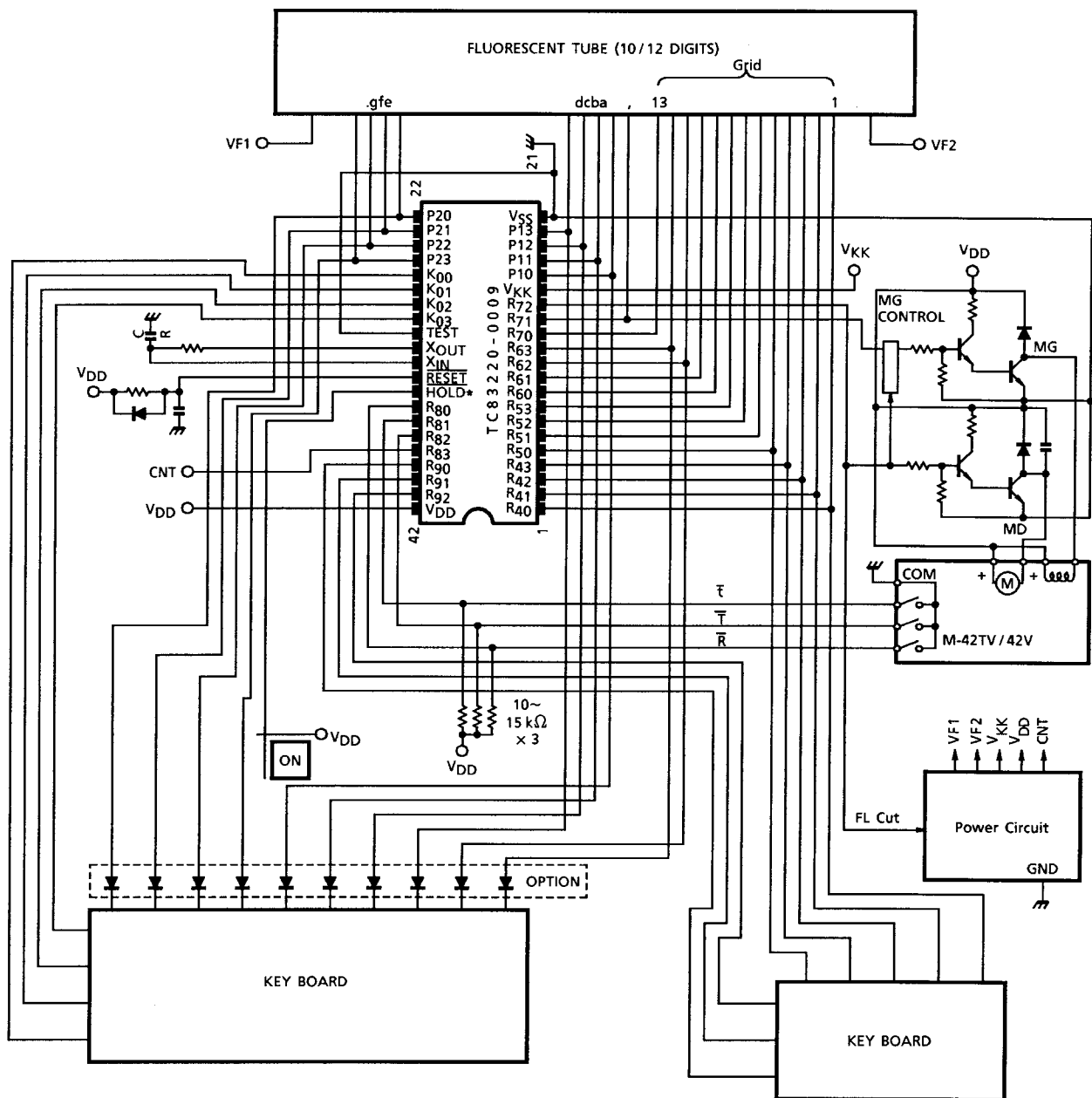

C = 100 pF

R = 1 kΩ ± 2%

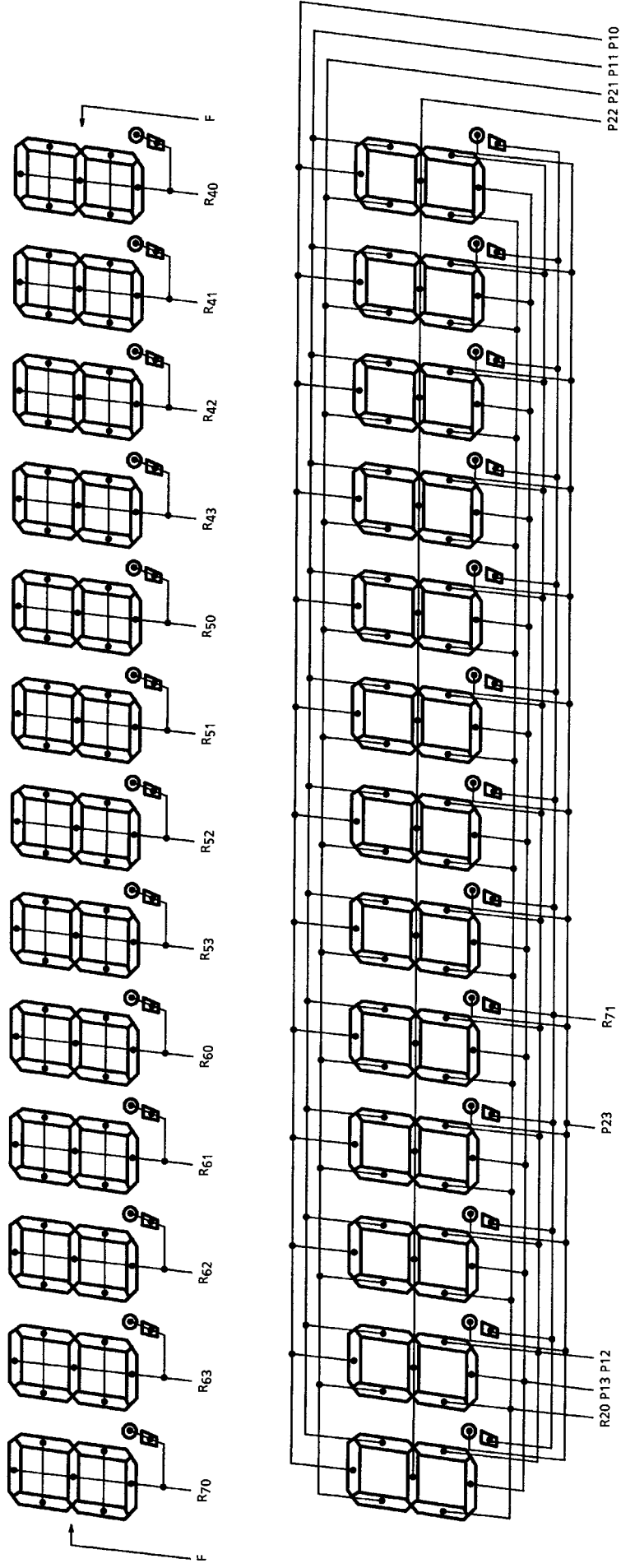
Connection of FL

Note 1: R70 digit (P10, P13, P20) of "E" data.

Note 2: R70 digit (P22) of "-" data.

Note 3: R70 digit (P23) of "M" data.

Note 4: R70 digit (P21) of "GT" data.

Key Connection

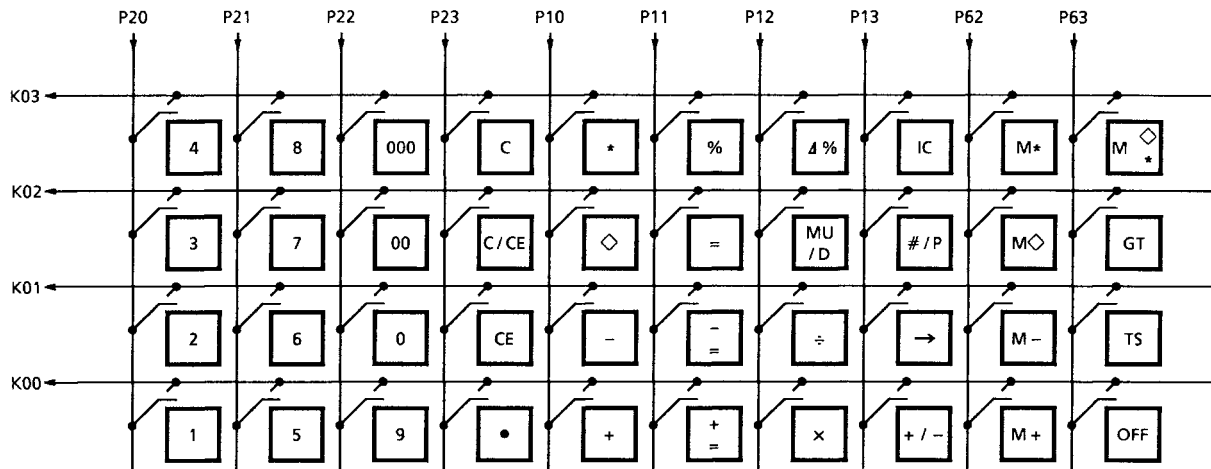

Touch Key

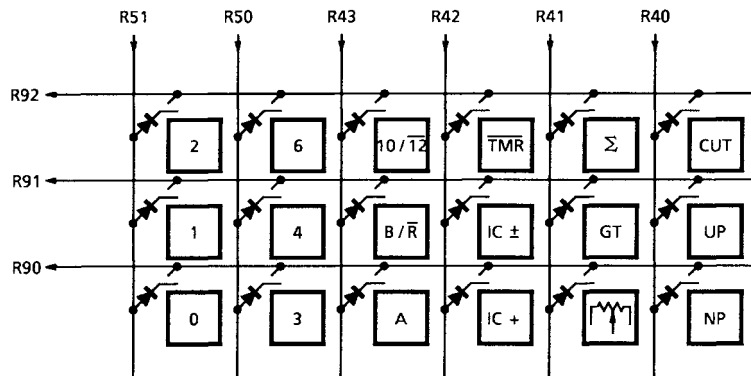

Lock Key

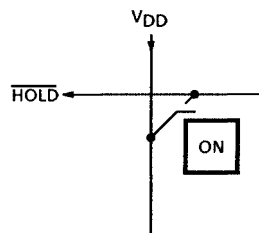

Operation Example

Key						Touch	Print		Display
TAB	4/5	IC	10/12	Σ	GT				
F	4/5	OFF	10	OFF	OFF	<ACL>	<PF>	C	
							<PF>		0.
						1+	1.	+	1.
						2-	2.	-	-1.
						◇	-1.	◇	-1.
						*	-1.	*	-1.
							<PF>		-1.
						IC	2.		2.
		IC+				1+	1.	+	1.
						2-	2.	-	-1.
						◇	002	◇	-1.
						*	002	*	-1.
							<PF>		-1.
						IC	2.		2.
						3×	3.	×	3.
						4÷	4.	÷	12.
						=	4.	=	
							3.	*	
							<PF>		3.
						5×	5.	×	5.
						6%	6.	%	
							0.3	*	
							<PF>		0.3
						+	5.3	+ %	
							<PF>		5.3
						2÷	2.	÷	2.
						3%	3.	%	
							66.66666666	*	66.66666666
							<PF>		2.
						2 MU/D	2.	G M	
						3=	3.	%	
							0.06185567	Δ *	
							2.06185567	*	
							<PF>		2.06185567
						2Δ%	2.	Δ	2.
						3=	3.	=	
							1.	Δ *	
							50.	Δ %	50.
							<PF>		

Note 5: <PF>Paper feed

Key							Print	Display
TAB	4/5	IC	10/12	Σ	GT	Touch		
F	4/5	OFF	10	Σ	OFF	3×	3. ×	3.
						4÷	4. ÷	12.
						=	4. =	
							3. +	
							<PF>	3.
						5×	5. ×	5.
						6%	6. %	
							0.3 +	
							<PF>	0.3
						+	5.3 + %	
							<PF>	5.3
						2÷	2. ÷	2.
						3%	3. %	
							66.66666666 +	
							<PF>	66.66666666
						2 MU/D	2. G M	2.
						3=	3. %	
							0.06185567 Δ *	
							2.06185567 +	
							<PF>	2.06185567
						2Δ%	2. Δ	2.
						3=	3. =	
							1. Δ *	
							50. +	
							<PF>	50.
						*	122.0285223 *	
							<PF>	122.0285223
						GT	0. G ∅	0.
					GT	2+	2. +	2.
						3+	3. +	3.
						*	5. G +	
							<PF>	G 5.
						3-	3. - R	G -3.
						4-	4. - R	G -4.
						5-	5. - R	G -5.
						*	-12. G + R	
							<PF>	G -12.
						GT	-7. G ∅ R	G -7.
						GT	-7. G * R	
							<PF>	-7.
					OFF	M+	-7. M + R	M -7.
						OFF		
						ON		M 0.
							<PF>	
						M∅	-7. M ∅ R	M -7.
						M*	-7. M * R	

Note 6: <PF>Paper feed

Key							Touch	Print		Display
TAB	4/5	IC	10/12	Σ	GT					
F	4/5	OFF	10	Σ	OFF			<PF>		-7.
						#/P		-7.	R	-7.
						2 #/P	#2		2.
						#/P		2.		2.
						0÷		0. ÷		0.
						=			
								0. *		
								<PF>	E	0.
						C		0. C		
								<PF>		0.

Note 7: <PF>Paper feed

Maximum Ratings ($V_{SS} = 0 \text{ V}$)

Characteristics	Symbol	Rating	Unit
Supply voltage 1	V_{DD}	-0.5~7	V
Supply voltage 2	V_{KK}	-40~+0.5	V
Input voltage	V_{IN}	-35~ $V_{DD} + 0.5$	V
Output voltage	V_{OUT}	-35~ $V_{DD} + 0.5$	V
Output current	I_{OUT}	-10	mA
Power dissipation ($T_{opr} = 70^\circ\text{C}$)	P_D	600	mW
Soldering temperature, time	T_{sld}	260 (10 s)	$^\circ\text{C}$
Storage temperature	T_{stg}	-55~125	$^\circ\text{C}$
Operating temperature	T_{opr}	0~40	$^\circ\text{C}$

Recommended Operating Conditions ($V_{SS} = 0 \text{ V}$)

Characteristics	Symbol	Test Circuit	Test Condition	Min	Max	Unit
Operating temperature	T_{opr}	—	—	0	40	$^\circ\text{C}$
Supply voltage	V_{DD}	—	—	4.5	6	V
Supply voltage (FL)	V_{KK}	—	—	-30	-15	V
Supply voltage (hold)	V_{DDH}	—	—	2	6	V
Input high voltage (except schmitt circuit input)	V_{IH1}	—	$V_{DD} \geq 4.5 \text{ V}$	$V_{DD} \times 0.7$	V_{DD}	V
Input high voltage (schmitt circuit input)	V_{IH2}	—		$V_{DD} \times 0.75$	V_{DD}	V
Input high voltage	V_{IH3}	—	$V_{DD} < 4.5 \text{ V}$	$V_{DD} \times 0.9$	V_{DD}	V
Input low voltage (except schmitt circuit input)	V_{IL1}	—	$V_{DD} \geq 4.5 \text{ V}$	V_{KK}	$V_{DD} \times 0.3$	V
Input low voltage (schmitt circuit input)	V_{IL2}	—		V_{KK}	$V_{DD} \times 0.25$	V
Input low voltage	V_{IL3}	—	$V_{DD} < 4.5 \text{ V}$	V_{KK}	$V_{DD} \times 0.1$	V
Output voltage (source open drain)	V_{OUT}	—	—	$V_{DD} - 35$	V_{DD}	V
Clock high pulse width (Note 5)	T_{WCH}	—	$V_{IN} = V_{IH}$	80	—	ns
Clock low pulse width (Note 5)	T_{WCL}	—	$V_{IN} = V_{IL}$	80	—	ns

Note 5: In case of the external clock operation.

Electrical Characteristics

DC Characteristics ($V_{SS} = 0\text{ V}$, $V_{DD} \pm 10\%$, $T_{opr} = 0\sim 40^\circ\text{C}$)

Characteristics	Symbol	Test Circuit	Test Condition	Min	Typ.	Max	Unit
Hysteresis voltage (schmitt circuit input)	V_{HS}	—	—	—	0.7	—	V
Input current ($\overline{\text{RESET}}$, $\overline{\text{HOLD}}$, $\overline{\text{TEST}}$)	I_{IN}	—	$V_{DD} = 5.5\text{ V}$, $V_{IN} = 5.5/0\text{ V}$	—	—	± 50	μA
Output leak current (source open drain)	I_{LO}	—	$V_{DD} = 5.5\text{ V}$, $V_{OUT} = -32\text{ V}$	—	—	-10	μA
Output high voltage (P1~P2, R4~R9)	V_{OH}	—	$V_{DD} = 4.5\text{ V}$, $I_{OH} = -6\text{ mA}$	2.4	—	—	V
Input pull down resistor (K0, R7~R9)	R_{IN}	—	$V_{DD} = 5.5\text{ V}$, $V_{KK} = -30\text{ V}$	—	100	—	$\text{k}\Omega$
Pull down resistor (source open drain)	R_{KK}	—		50	80	200	$\text{k}\Omega$
Operating supply current	I_{DD0}	—	V_{DD} (V_{DDH}) 5.5 V , $f_c = 4\text{ MHz}$, $V_{IN} = 5.3/0.2\text{ V}$	—	3	6	mA
Supply current (after clear)	I_{KK1}	—	$V_{KK} = -30\text{ V}$, $f_c = 4\text{ MHz}$	—	0.6	0.9	mA
Supply current (shown full digits)	I_{KK2}	—		—	3.5	6	mA
Holding supply current	I_{DDH}	—	$V_{DD} = 5.5\text{ V}$	—	0.5	10	μA
Oscillating frequency	F_ϕ	—	$V_{DD} = 5.0\text{ V}$, $C = 100\text{ pF}$ $R = 1\text{ k}\Omega \pm 2\%$	2.4	4.0	5.6	MHz

Package Dimensions

SDIP42-P-600-1.78

Unit : mm

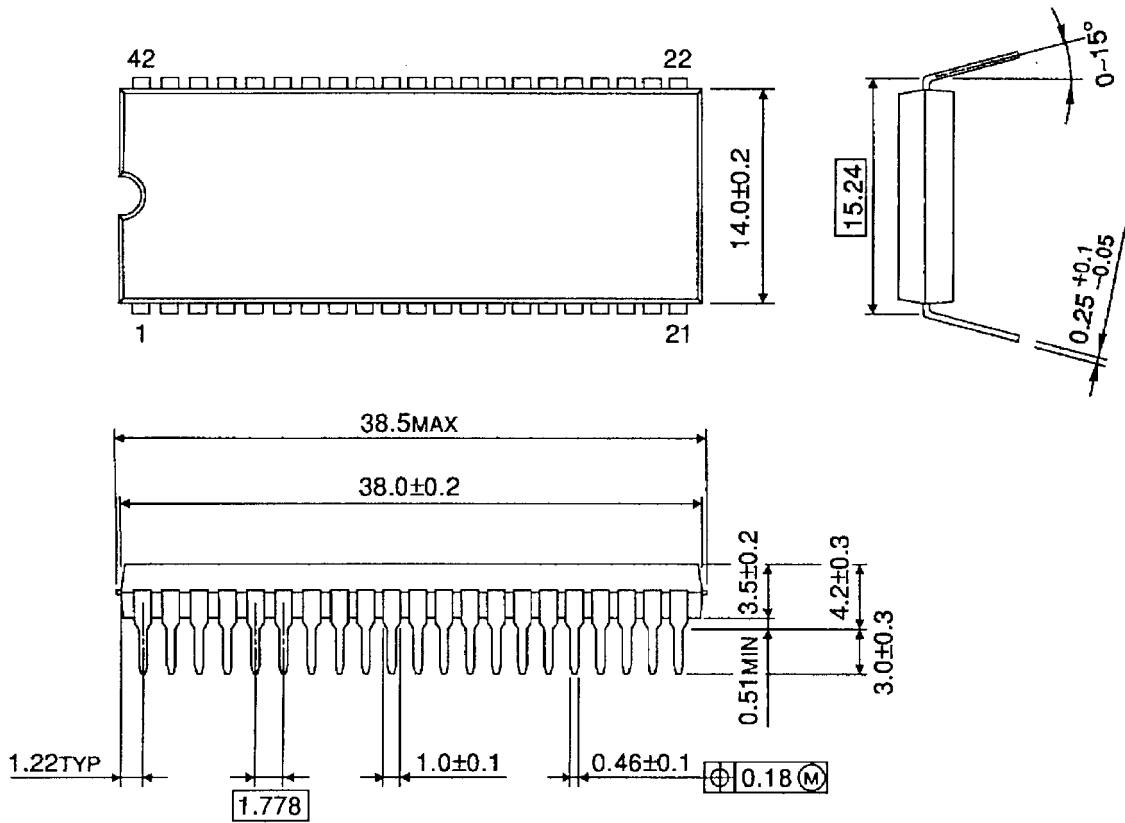

Weight: 4.12 g (typ.)

RESTRICTIONS ON PRODUCT USE

000707EBA

- TOSHIBA is continually working to improve the quality and reliability of its products. Nevertheless, semiconductor devices in general can malfunction or fail due to their inherent electrical sensitivity and vulnerability to physical stress. It is the responsibility of the buyer, when utilizing TOSHIBA products, to comply with the standards of safety in making a safe design for the entire system, and to avoid situations in which a malfunction or failure of such TOSHIBA products could cause loss of human life, bodily injury or damage to property.
In developing your designs, please ensure that TOSHIBA products are used within specified operating ranges as set forth in the most recent TOSHIBA products specifications. Also, please keep in mind the precautions and conditions set forth in the "Handling Guide for Semiconductor Devices," or "TOSHIBA Semiconductor Reliability Handbook" etc..
- The TOSHIBA products listed in this document are intended for usage in general electronics applications (computer, personal equipment, office equipment, measuring equipment, industrial robotics, domestic appliances, etc.). These TOSHIBA products are neither intended nor warranted for usage in equipment that requires extraordinarily high quality and/or reliability or a malfunction or failure of which may cause loss of human life or bodily injury ("Unintended Usage"). Unintended Usage include atomic energy control instruments, airplane or spaceship instruments, transportation instruments, traffic signal instruments, combustion control instruments, medical instruments, all types of safety devices, etc.. Unintended Usage of TOSHIBA products listed in this document shall be made at the customer's own risk.
- The products described in this document are subject to the foreign exchange and foreign trade laws.
- The information contained herein is presented only as a guide for the applications of our products. No responsibility is assumed by TOSHIBA CORPORATION for any infringements of intellectual property or other rights of the third parties which may result from its use. No license is granted by implication or otherwise under any intellectual property or other rights of TOSHIBA CORPORATION or others.
- The information contained herein is subject to change without notice.