



MOTOROLA

TCA3388

Advance Information Telephone Line Interface

The TCA3388 is a telephone line interface circuit which performs the basic functions of a telephone set in combination with a microcontroller and a ringer. It includes dc and ac line termination, the hybrid function with 2 adjustable sidetone networks, handset connections and an efficient supply point.

FEATURES

Line Driver and Supply

- DC and AC Termination of the Telephone Line
- Selectable DC Mask: France, U.K., Low Voltage
- Current Protection
- Adjustable Set Impedance for Resistive and Complex Termination
- Efficient Supply Point for Peripherals
- Hook Status Detection

Handset Operation

- Transmit and Receive Amplifiers
- Double Anti-Sidetone Network
- Line Length AGC
- Microphone and Earpiece Mute
- Transmit Amplifier Soft Clipping

Dialing and Ringing

- Interrupter Driver for Pulse-Dialing
- Reduced Current Consumption During Pulse-Dialing
- DTMF Interfacing
- Ringing via External Ringer

Application Areas

- Corded Telephony
- Cordless Telephony Base Station
- Answering Machines
- Fax
- Intercom
- Modem

TELEPHONE LINE INTERFACE

SEMICONDUCTOR TECHNICAL DATA

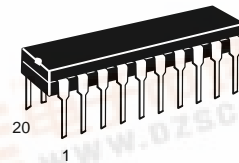

DP SUFFIX
PLASTIC PACKAGE
CASE 738

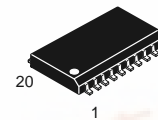

FP SUFFIX
PLASTIC PACKAGE
CASE 751D

PIN CONNECTIONS

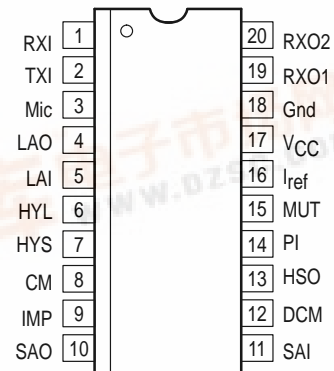

(Top View)

ORDERING INFORMATION

Device	Tested Operating Temperature Range	Package
TCA3388DP	T _A = 0° to +70°C	DIP
TCA3388FP		SOIC



TCA3388

Simplified Block Diagram

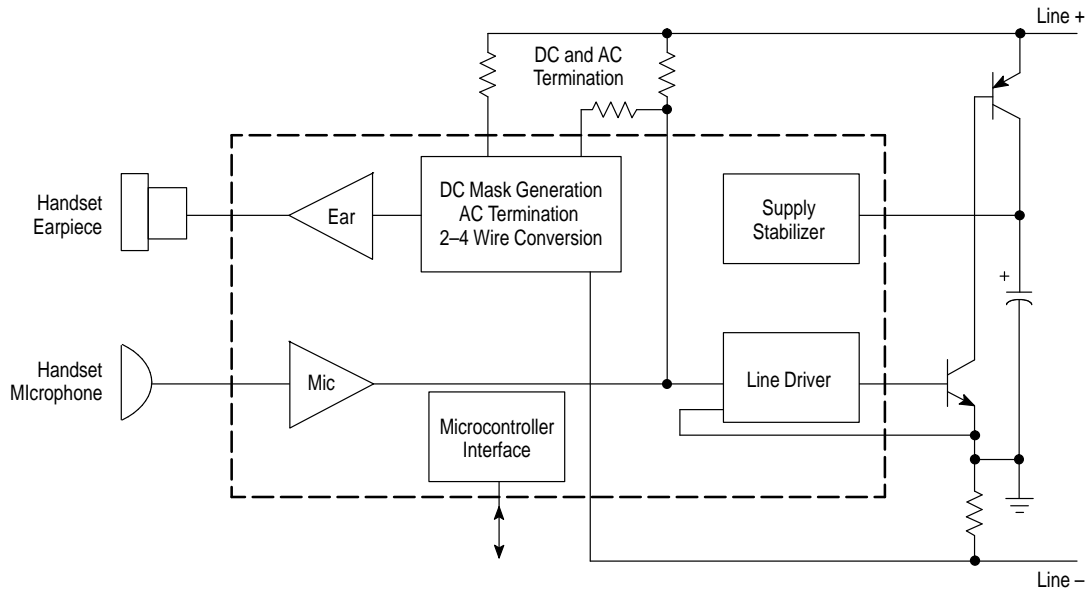

This device contains 1,911 active transistors.

MAXIMUM RATINGS

Rating	Symbol	Min	Max	Unit
Maximum Junction Temperature	T_J	–	+150	°C
Storage Temperature Range	T_{stg}	–65	+150	°C

NOTE: Devices should not be operated at or outside these values. The "Recommended Operating Limits" provide for actual device operation.

RECOMMENDED OPERATING CONDITIONS

Characteristic	Symbol	Min	Typ	Max	Unit
Operating Temperature Range	T_A	0	–	+70	°C

DC ELECTRICAL CHARACTERISTICS ($T_A = 25^\circ\text{C}$)

Characteristic	Symbol	Min	Typ	Max	Unit
----------------	--------	-----	-----	-----	------

VOLTAGE REGULATOR

Regulated Supply at Pin 17 $I_{CC} = 7.0 \text{ mA}$ $I_{CC} = 20 \text{ mA}$ $I_{CC} = 80 \text{ mA}$	V_{CC}	3.4 3.45 3.5	3.7 3.75 3.8	4.0 4.05 4.1	Vdc
Current Consumption at Pin 17, Pin PI = High	I_{CC}	–	–	600	μA

DRIVER DC CHARACTERISTICS

Available Current at LAO Source Current Sink Current	I_4	45 –100	70 –70	100 –45	μA
Amplifier A8 Driver Slope	S8	0.7	1.0	1.2	$\mu\text{A}/\text{mV}$
LAO Voltage (PI = High, $I_4 = 100 \mu\text{A}$)	V_{LAO}	–	–	270	mV
Internal Offset (Pins 5 to 10)	$VO1-VO2$	30	80	140	mV

SPEECH AMPLIFIERS

IMP Voltage (Pin 9, Closed Loop)	V_{IMP}	–	1.6	–	Vdc
Earpiece Amplifier DC Bias ($R_{ext} = 100 \text{ k}\Omega$) RXI, Pin 1 RXO1 Pin 19 RXO2, Pin 20 Offset ($V_{RXO1} - V_{RXO2}$)	V_{RXI} V_{RXO1} V_{RXO2} V_{Offset}	– – – –	1.6 1.7 1.45 0.25	– – – 0.70	Vdc

TCA3388

DC ELECTRICAL CHARACTERISTICS (continued) (T_A = 25°C)

Characteristic	Symbol	Min	Typ	Max	Unit
SPEECH AMPLIFIERS					
HYL and HYS DC Bias Voltage Normal Mode PI = High	V _{HY1} V _{HY2}	– –	2.4 1.4	– –	V _{dc}
Microphone Amplifier DC Bias at TXI	V _{TXI}	–	1.45	–	V _{dc}
Saturation Voltage at Mic @ 1.0 mA	V _{Mic}	–	250	300	mV
Leakage Current into Mic @ 3.7 V	I _{Leak}	–	–	2.0	μA
HOOK STATUS OUTPUT (Pin 13)					
High Level Voltage @ – 5.0 μA Load Current, Off-Hook, V _{SAI} = Max	V _{HSHO}	2.7	2.9	–	V _{dc}
Maximum Load Current Normal Mode PABX Mode	I _{HSOL} I _{HSHO}	– 20	– –	5.0 –	μA
Low Level Voltage @ + 5.0 μA Load Current, V _{SAI} = – 5.0 mV Normal On-Hook PI = High	V _{HSOL} V _{HSOLPI}	– 2.7	– 2.9	0.60 –	V _{dc}
Time Delay from On-Hook or Off-Hook	T _{Del}	–	3.5	–	ms
PULSE INPUT (Pin 14)					
Input Impedance	Z _{PI}	–	160	–	kΩ
DC Bias Voltage	V _{PIL}	–	1.4	–	V _{dc}
Input Current Make Phase Break Phase	I _{PIL} I _{PIH}	–1.0 –10	– –	1.0 10	μA
MUTE INPUT (Pin 15)					
Input Impedance	Z _{MI}	–	160	–	kΩ
DC Bias Voltage	V _{MI}	–	1.4	–	V _{dc}
Input Current Speech Mode Mute Mode	I _{MIL} I _{MIH}	–1.0 –10	– –	1.0 10	μA
DC MASK CHARACTERISTICS					
French Internal Slope Voltage on SAI (I _{2C} = 3.6 μA) Voltage on SAI (I _{2D} = 4.0 μA) Delta Offset Voltage on SAI (I _{2E} = 30 μA)	R _I V _C V _D V _E –V _D	120 0.40 – –	160 0.47 0.49 –	200 – 0.57 30	mV/μA V _{dc} V _{dc} mV
U.K. Internal Slope Voltage on SAI (I _{2C} = 3.5 μA) Voltage on SAI (I _{2D} = 3.9 μA) Delta Offset Voltage on SAI (I _{2E} = 30 μA)	R _I V _C V _D V _E –V _D	210 0.59 – –	260 0.70 0.72 20	310 – 0.83 50	mV/μA V _{dc} V _{dc} mV
Low Voltage Mode Internal Slope Voltage on SAI (I _{2C} = 13 μA) Voltage on SAI (I _{2D} = 15 μA) Delta Offset Voltage on SAI (I _{2E} = 20 μA)	R _I V _C V _D V _E –V _D	100 1.0 – –	125 1.2 1.3 –	150 – 1.55 100	mV/μA V _{dc} V _{dc} mV
Overvoltage Protection Threshold (V _{LAI} – V _{SAO}) French and U.K. DC Masks Low Voltage DC Mask	V _{Clamp1}	530 280	580 –	650 385	mV
Protection Voltage Level (V _{LAI} – V _{SAO}) French and U.K. DC Masks Low Voltage DC Mask	V _{Clamp2}	350 280	– –	440 440	mV

TCA3388

AC ELECTRICAL CHARACTERISTICS (T_A = 25°C)

Characteristic	Symbol	Min	Typ	Max	Unit
TRANSMIT MODE					
French and U.K. Maximum Transmit Gain (I ₂ = 3.0 μA)	K _{μ0}	11.25	12.5	13.75	dB
Line Length Regulation (I ₂ = 30 μA)	ΔK _μ	5.5	6.5	7.5	
Gain in Protection Mode (I ₂ = 30 μA)	K _{μp}	10.5	12.5	14.5	
Low Voltage Mode Maximum Transmit Gain (I ₂ = 3.0 μA)	K _{μ0}	11.25	12.5	13.75	dB
Line Length Regulation (I ₂ = 8.2 μA)	ΔK _μ	4.5	6.0	7.5	
Gain in Protection Mode (I ₂ = 8.2 μA)	K _{μp}	10.5	12.5	14.5	
Gain Reduction when Microphone is Muted	ΔK _{μm}	60	–	–	dB
RECEIVE MODE					
French Maximum Internal Transconductance (I ₂ = 3.0 μA)	G _{e0}	150	180	210	μA/V
Line Length Regulation (I ₂ = 18 μA)	ΔG _e	2.95	3.7	4.45	dB
Hybrid Weighting Factor (I ₂ = 18 μA)	m _r	0.4	0.5	0.6	
Line Length Regulation (HYS @ V _{CC} , I ₂ = 9.0 μA)	ΔG _e	1.5	2.1	2.5	dB
Protection Mode (I ₂ = 18 μA)	G _{ep}	145	185	230	
U.K. Maximum Internal Transconductance (I ₂ = 3.0 μA)	G _{e0}	150	180	210	μA/V
Line Length Regulation (I ₂ = 18 μA)	ΔG _e	2.8	3.5	4.3	dB
Hybrid Weighting Factor (I ₂ = 13 μA)	m _r	0.4	0.5	0.6	
Line Length Regulation (HYS @ V _{CC} , I ₂ = 9.0 μA)	ΔG _e	1.4	1.9	2.4	dB
Protection Mode (I ₂ = 18 μA)	G _{ep}	145	185	230	
Low Voltage Mode Maximum Internal Transconductance (I ₂ = 3.0 μA)	G _{e0}	150	185	210	μA/V
Line Length Regulation (I ₂ = 8.0 μA)	ΔG _e	4.2	5.7	7.2	dB
Hybrid Weighting Factor (I ₂ = 7.0 μA)	m _r	–	0.5	–	
Line Length Regulation (HYS @ V _{CC} , I ₂ = 4.0 μA)	ΔG _e	–	3.0	–	dB
Protection Mode (I ₂ = 8.0 μA)	G _{ep}	145	185	230	
Earpiece Gain Reduction when Muted	ΔG _{em}	60	–	–	dB
TRANSMIT PABX MODE					
French and U.K. Transmit Gain (I ₂ = 3.0 μA)	K _{PABX}	9.25	10.5	11.75	dB
Variation with Line Length (I ₂ = 30 μA)	ΔK _{PABX}	– 0.5	–	0.5	
Low Voltage Mode Transmit Gain (I ₂ = 3.0 μA)	K _{PABX}	9.25	10.5	11.75	dB
Variation with Line Length (I ₂ = 30 μA)	ΔK _{PABX}	– 0.5	–	0.5	
RECEIVE PABX MODE					
French Internal Transconductance (I ₂ = 5.0 μA)	G _{PABX}	120	145	170	μA/V
Hybrid Weighting Factor (I ₂ = 5.0 μA)	m _r	0.8	0.9	1.0	dB
Variation with Line Length (I ₂ = 30 μA)	ΔG _{PABX}	– 0.5	–	0.5	
U.K. Internal Transconductance (I ₂ = 5.0 μA)	G _{PABX}	120	145	170	μA/V
Hybrid Weighting Factor (I ₂ = 5.0 μA)	m _r	0.65	0.75	0.85	dB
Variation with Line Length (I ₂ = 30 μA)	ΔG _{PABX}	– 0.5	–	0.5	
Low Voltage Mode Internal Transconductance (I ₂ = 3.0 μA)	G _{PABX}	120	145	170	μA/V
Hybrid Weighting Factor (I ₂ = 3.0 μA)	m _r	–	0.9	–	dB
Variation with Line Length (I ₂ = 30 μA)	ΔG _{PABX}	– 0.5	–	0.5	
DISTORTION					
French Transmit (I ₂ = 10 μA)	THDT	–	–	3.0	%
Receive (I ₂ = 6.0 μA)	THDR	–	–	3.0	
	–	–	–	5.0	

NOTE: V_E is the differential earpiece voltage across Pins 19 and 20.

TCA3388

AC ELECTRICAL CHARACTERISTICS (continued) (T_A = 25°C)

Characteristic	Symbol	Min	Typ	Max	Unit
DISTORTION					
Low Voltage Transmit (I ₂ = 10 μA) Receive (I ₂ = 6.0 μA)	THDT THDR	– – –	– – –	3.0 3.0 5.0	%
	V _E = 700 mV V _E = 1250 mV				

NOTE: V_E is the differential earpiece voltage across Pins 19 and 20.

TYPICAL TEMPERATURE PERFORMANCE

Characteristic	Typical Value @ 25°C	Typical Change – 20 to + 60°C
V _{CC} Regulated Supply @ Pin 17	3.7	– 0.8 mV/°C
Current Consumption at Pin 17, Pin PI = High	400 μA	– 0.55 μA/°C
Amplifier A8 Driver Slope	1.0 μA/mV	– 0.0035 μA/mV/°C
Voltage on SAI V _C V _D	French = 0.47 Vdc U.K. = 0.70 Vdc French = 0.49 Vdc U.K. = 0.72 Vdc	0.35 mV/°C
Internal Slope for Low Voltage Mode	125 mV/μA	0.07 mV/μA/°C
Transmit Gain K _{μ0}	12.5 dB	0.01 dB/°C
Line Length Regulation ΔK _μ French U.K. L.V.	6.5 dB 6.5 dB 6.0 dB	< 0.3 dB Variation < 0.3 dB Variation – 0.05 dB/°C
Internal Transconductance G _{e0}	180 μA/V	< 1.0 dB Variation
Line Length Regulation ΔG _e French U.K. L.V.	3.7 dB 3.5 dB 5.7 dB	< 0.5 dB Variation < 0.5 dB Variation – 0.04 dB/°C

NOTE: Temperature data is typical performance only, based on sample characterization, and does not provide guaranteed limits over temperature.

PIN FUNCTION DESCRIPTION

Pin	Symbol	Description
1	RXI	Earphone Amplifier Input
2	TXI	Microphone Amplifier Input
3	Mic	Microphone Bias Current Sink
4	LAO	Line Driver Amplifier Output
5	LAI	Line Driver Amplifier Input
6	HYL	Hybrid Network Input for Long Lines
7	HYS	Hybrid Network Input for Short Lines
8	CM	DC Mask Signal Filtering
9	IMP	Reference Voltage
10	SAO	Line Current Sense Amplifier Output
11	SAI	Line Current Sense Amplifier Input
12	DCM	DC Mask Select
13	HSO	Hook Status Output, PABX Mode Select
14	PI	Pulse Input
15	MUT	Mute Input
16	I _{ref}	Reference Current
17	V _{CC}	Supply Voltage
18	Gnd	Ground
19	RXO1	Earphone Amplifier Output
20	RXO2	Earphone Amplifier Inverted Output

TCA3388

DESCRIPTION OF THE CIRCUIT

Concept

With a TCA3388, a microcontroller and a ringer, a basic telephone set can be built according to the concept depicted in Figure 1.

In off-hook position, the application is in speech mode. The line current flows through transistor T2 and supplies the externals (microcontroller) at the supply point V_{CC} which is stabilized by the TCA3388. The V_{line} , I_{line} characteristic is adjusted by the external components Z0, Z1, Z21 and R1 which are in a regulator loop, acting on transistor T2. The ac

impedance is generated in a similar way. The handset can be connected directly to the TCA3388. Via a logic level interface, the microcontroller drives the TCA3388 to perform the DTMF/pulse-dialing. The user keyboard has to be connected to the microcontroller. In on-hook position, a ringing melody can be generated with a ringer application.

The block diagram of the TCA3388, in Figure 2, shows the basic blocks of the device plus the essential external components.

Figure 1. Telephone Concept with TCA3388

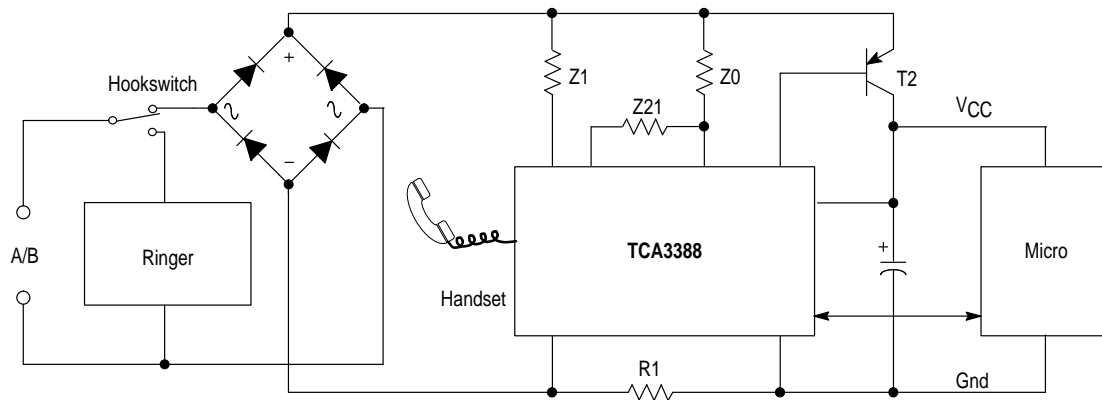
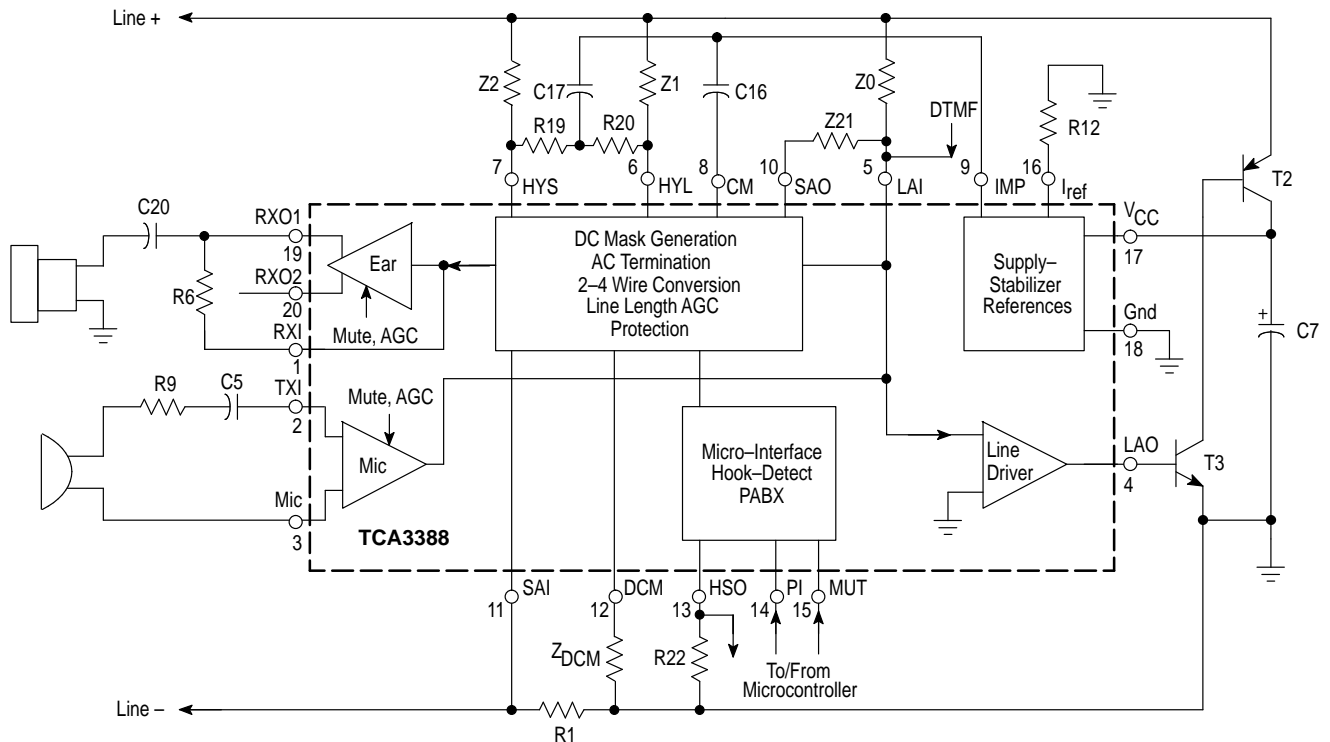

Figure 2. Block Diagram of the TCA3388 with Essential Components



TCA3388

DC CHARACTERISTICS AND STARTUP

The dc mask has the general form as depicted in Figure 3. The TCA3388 offers the possibility to adjust the dc characteristics of all 4 regions via mask selection and hardware adjustments.

The selection of the 3 masks, France, United Kingdom and Low Voltage, can be done via the Z_{DCM} network at Pin DCM as shown in Figure 4. For French and U.K. masks, the region 3 with the high slope is within the normal dc feeding conditions. For Low Voltage mask the region 3 will be outside this and the dc mask is mainly determined by regions 1 and 2.

Figure 3. General Form of the DC Mask of the TCA3388

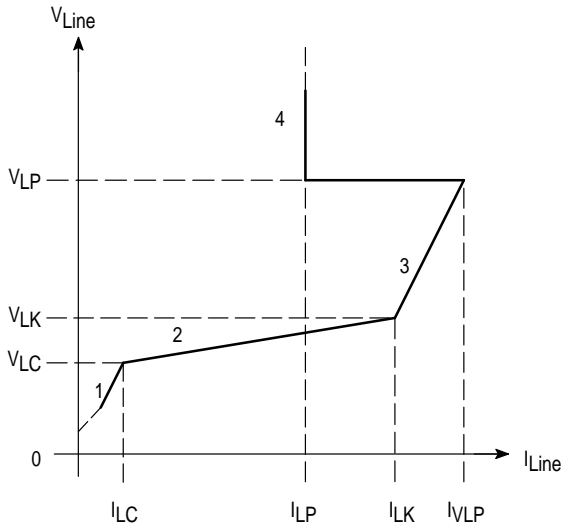

- Region 1: Startup, Low Line Current, High Slope
- Region 2: Mid-Range Line Current, Low Slope
- Region 3: High Line Current, High Slope
- Region 4: Overload Protection

Figure 4. Selection of the Country Mask via Pin DCM

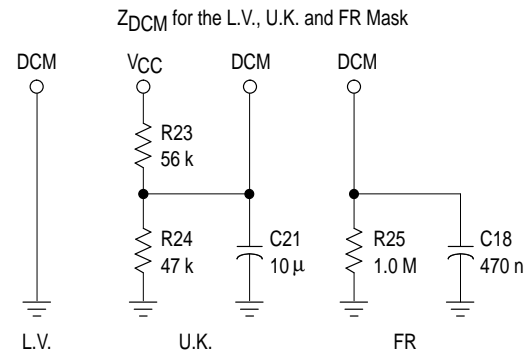
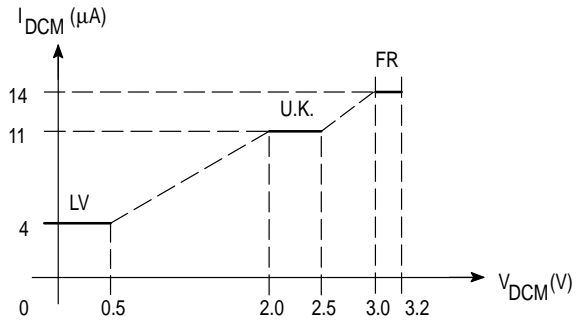

The capacitor in the U.K. network is to ensure a stable selection of the mask during all working modes and transitions. The capacitor in the French network is used to create a startup in Low Voltage Mask.

The adjustment possibilities will be discussed below with the aid of the block diagram of Figure 5.

Figure 5. DC Part of the Block Diagram of the TCA3388

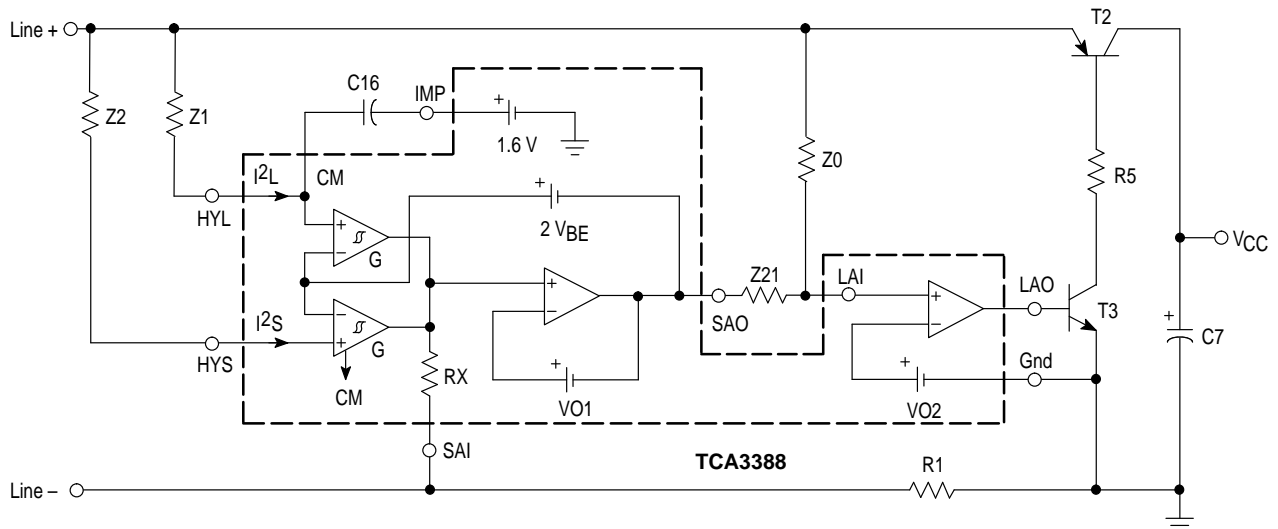

TCA3388

The TCA3388 offers the possibility to connect 2 sidetone networks Z1 and Z2. For correct dc operation, the dc impedance of these networks must be equal. When only 1 sidetone network is used, Pin HYS has to be connected to HYL. All formulas below are based on a single sidetone network, so only Z1 appears. When 2 sidetone networks are used, Z1 has to be replaced by Z1//Z2.

In region 1, the transfer of the amplifier G at the HYL/HYS inputs equals zero. The voltage difference between SAO and SAI will equal VO1. The slope RE1 of the VLine, ILine characteristic will equal:

$$R_{E1} = R1 \times \left(1 + \frac{Z0}{Z21} \right)$$

In region 2, the output current of the amplifier G will be proportional to the input current. As a result the voltage between SAO and SAI will increase with the line voltage. Speech signals on the line are of no influence on this because they are filtered out via capacitor C16. The slope RE2 of the VLine, ILine characteristic will equal:

$$R_{E2} = R1 \times \left(1 + \frac{1}{\frac{R1}{Z1} + \frac{Z21}{Z0}} \right)$$

In region 3, the output current of the amplifier G is kept constant. As a result the slope in region 3 will equal the slope of region 1.

The transfer from region 2 to 3 occurs at the point VLK, ILK defined by:

$$V_{LK} = Z1 \times I2CD + 2 V_{BE} + V_{CD} + VO2$$

$$I_{LK} = \frac{\frac{Z21}{Z0} \times (Z1 \times I2CD + 2 V_{BE}) + V_{CD}}{R1}$$

$$\text{With: } I2CD = \frac{I2C + I2D}{2}, \text{ and } V_{CD} = \frac{V_C + V_D}{2},$$

$$\text{and } 2 V_{BE} \approx 1.4 \text{ V}, V02 \approx 1.1 \text{ V}$$

When the French or U.K. mask is selected, this transfer takes place for line currents of 30 mA to 40 mA depending on the components settings. With the Startup and Low Voltage mask, the transfer lies outside the normal operating range with line currents of 90 mA or more. In most applications the transfer from region 1 to 2 takes place for line currents below 10 mA.

With proper settings, region 4 is entered only during an overload condition. In this mode, the power consumption in the telephone set is limited. In order to detect an overload condition, the voltage between the Pins LAI and SAO is monitored. When the voltage difference is larger than the threshold VClamp1, the protection is made active. The relation for the line voltage VLP at this point is given as:

$$V_{LP} = \frac{Z0}{Z21} \times V_{Clamp1} + V_{CD} + VO2$$

When the protection mode is entered, the line current is reduced to a lower value ILP of:

$$I_{LP} = \frac{V_{Clamp2} + (VO1 - VO2)}{R1}$$

When the line voltage becomes lower than VLP, the overload condition is removed and the TCA3388 will leave region 4.

The current drawn from the line by the dc part is used to supply the TCA3388 and peripheral circuits. The excess loop current is absorbed by the voltage regulator at Pin VCC, where a filter capacitor is connected. The reference for the circuit is Pin Gnd.

Startup of the application is ensured by an internal startup circuit. When the line current flows, the hook status output pin HSO goes high. This informs the microcontroller that the set is off-hook. When the line current is no longer present the pin will go low again. Because the line current is monitored, and not the line voltage, also an interrupt of the exchange can be recognized.

AC CHARACTERISTICS

Impedance

In Figure 6, the block diagram of the TCA3388 performing the ac impedance is depicted. As can be seen it is partly common with the dc mask block diagram. The part generating the dc mask is replaced by a dc voltage source because for ac, this part has no influence.

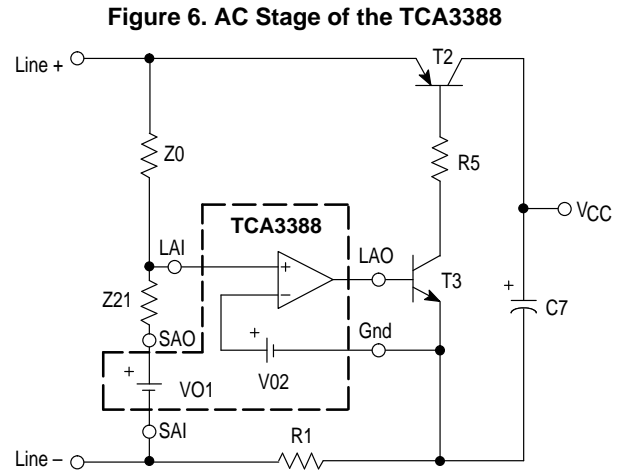

When calculating the ac loop, it can be derived that the set impedance Zin equals

$$Z_{in} = \frac{V_{Line}}{I_{Line}} = R1 \left(1 + \frac{Z0}{Z21} \right) \approx R1 \times \frac{Z0}{Z21}$$

As can be noticed, the formula for the ac impedance Zin equals the formula for the dc slope in regions 1 and 3. However, because for the dc slope the resistive part of Z0 and Z21 are used, the actual values for Zin and the dc slopes do not have to be equal.

A complex impedance can be made by making either Z0 or Z21 complex. When Z0 is made complex to fit the set impedance the transmit characteristics will be complex as well. The complex impedance is therefore preferably made via the Z21 network. Because Z21 is in the denominator of the Zin formula, Z21 will not be a direct copy of the required impedance but a derivative of it. Figure 7 gives this derived network to be used for Z21.

TCA3388

Figure 7. Derived Network for Z21 in Case of Complex Set Impedance

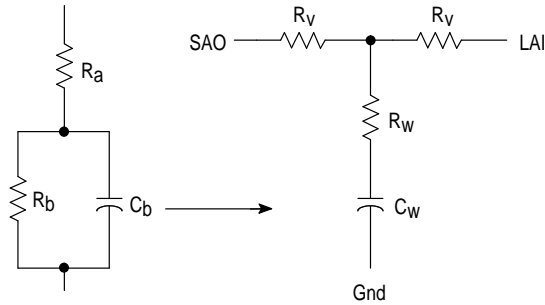

$$R_v = \frac{R_1 \times Z_0}{2(R_a + R_b - R_1)}$$

$$R_w = \frac{R_1 \times Z_0 (R_a - R_1)}{4 R_b (R_a + R_b - R_1)}$$

$$C_w = \frac{4 R_b^2 \times C_b}{R_1 \times Z_0}$$

TRANSMIT

When a current is injected on Pin LAI, via the loop depicted in Figure 6, a signal is created on the line. In this way the microphone signals and DTMF signals (from an external source) are transmitted. It can be derived that the signal voltage on the line (V_{Line}) depends on the signal current injected in LAI (I_{LAI}) according to:

$$V_{Line} = -I_{LAI} \times \frac{Z_0 \times Z_{Line}}{Z_{in} + Z_{Line}}$$

With this relation, a simplified replacement circuit can be made for the transmit amplifier (see Figure 8). Here the product of I_{LAI} and Z_0 is replaced by one voltage source.

Figure 8. Replacement Diagram for the Transmit Amplifier

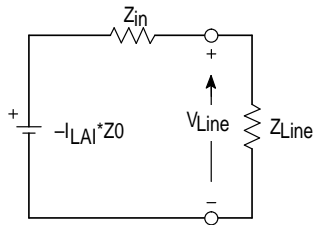

The microphone signal current is derived from the microphone signal according to the schematic in Figure 9.

Figure 9. Microphone Amplifier Input Stage

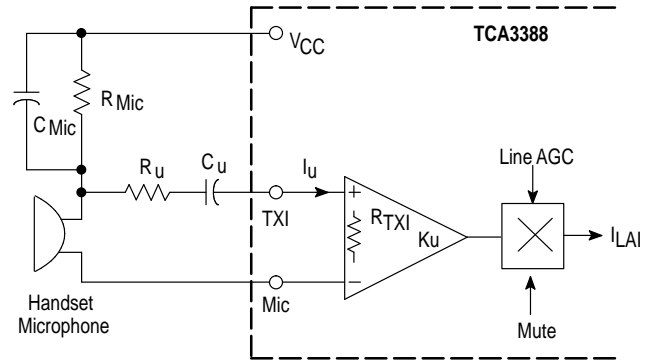

The input stage of Figure 9 consists of a current amplifier with transfer K_u , an input impedance of 1.0 k (R_{TXI}), plus an attenuator which reduces the signal current at high line currents (AGC). This attenuator can be switched on/off via the microcontroller. The input current I_u within the telephony speech band is derived from the microphone signal according

$$I_u = \frac{V_u}{R_{Mic} + R_u + R_{TXI}} \approx \frac{V_u}{R_u}$$

With: V_u = signal of the microphone only loaded with R_{Mic}

The overall gain from microphone to line (A_{TX}) now follows as

$$A_{TX} = \frac{V_{Line}}{V_u} = \frac{K_u}{R_u} \times \frac{Z_0 \times Z_{Line}}{Z_{in} + Z_{Line}}$$

Practically, the gain can be varied only with Z_0 , R_u and R_{Mic} .

The TCA3388 offers the possibility to mute the microphone, also called privacy mode, by making the MUT Pin high. During pulse-dialing, the microphone bias is switched off. Pin Mic will be made high impedance, shutting off the microphone dc current. This reduces the current consumption of the circuit during pulse-dialing.

TCA3388

Figure 10. Receive Part of the TCA3388

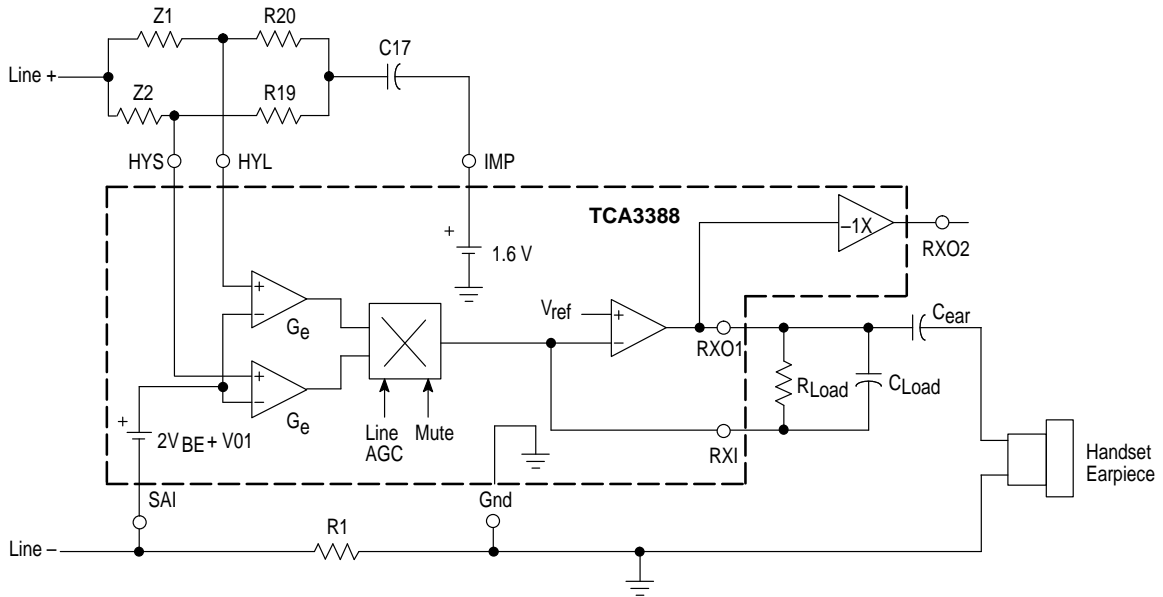

RECEIVE

The receive part of the TCA3388 is shown in Figure 10.

The receive signal is picked up by the amplifiers at the HYL/HYS inputs. These are the same amplifiers present in the dc loop of Figure 5. The signal is first converted to current by the transconductance amplifier with transfer G_e . The multiplier placed after performs the line length AGC. It switches over between the 2 signals at HYS and HYL according to the line current via a modulation factor m . Afterwards, the current is converted back to voltage via the external feedback network Z_{Load} . The resulting voltage is available at output RXO1, and inverted at RXO2.

From the diagram of Figure 10 the receive gain (A_{RX}) can be derived as:

$$A_{RX} = \frac{V_{RXO}}{V_{Line}} = G_e \times R1 \times Z_{Load} \times \left(\frac{1}{Z_H} + \frac{1}{Z_{in}} \right)$$

With: $\frac{1}{Z_H} = \frac{R20}{R1 \times Z1}$ in case of 1 sidetone network and

HYS connected to HYL, or

$$\frac{1}{Z_H} = m \times \frac{R20}{R1 \times Z1} + (m - 1) \frac{R19}{R1 \times Z2}$$
 in case of

2 sidetone networks

More information on Z_H and the modulation factor m can be found under the sidetone characteristics.

The earpiece can either be connected as a single ended or as a differential load. The above calculated gain is valid for the single ended case. When connecting as a differential load, the gain is increased by 6.0 dB. The TCA3388 offers the possibility to mute the signal coming from the line to the earpiece. This can be useful during pulse- and DTMF-dialing.

SIDETONE

When a transmit signal is transmitted to the line, a part of the signal is returned to the receive channel due to the architecture of the 2 to 4 wire conversion of the hybrid. During transmit, the signal on the line will be $-I_{Line} \times Z_{Line}$. During receive, the signal on the line will be $I_{Line} \times Z_{in}$. When replacing Z_{in} in the formula for the receive gain, it follows that the signal on the earpiece output due to a sending signal on the line will be:

$$\frac{V_{ear}}{V_{Line} \text{ (transmit)}} = G_e \times R1 \times Z_{Load} \times \left(\frac{1}{Z_H} - \frac{1}{Z_{Line}} \right)$$

In applications with 1 sidetone network where HYS is connected to HYL, it follows:

$$\frac{1}{Z_H} = \frac{R20}{R1 \times Z1} = \frac{1}{Z_{HL}}$$

Z_H has to be chosen according the average line impedance, and the average linelength of the countries involved in the application. A complex sidetone network can be made via a complex $Z1$ which is preferred above making $R20$ complex. The coupling capacitor $C17$ in series with $R20$ is meant only to block dc.

For applications with 2 sidetone networks it follows:

$$\frac{1}{Z_H} = m \frac{R20}{R1 \times Z1} + (m - 1) \frac{R19}{R1 \times Z2} = m \frac{1}{Z_{HL}} + (m - 1) \frac{1}{Z_{HS}}$$

The Z_H thus exists as Z_{HL} for long lines with low line currents and as Z_{HS} for short lines with high line currents. This can be useful in applications such as DECT and handsfree where the sidetone has to be minimized to reduce the effect of delayed echoing and howling respectively. The TCA3388 will automatically switch over between the 2 hybrid networks as a function of line current. This is expressed in the

TCA3388

factor m . The relation between the line current and the factor m is depicted in Figure 11.

Figure 11. Modulation Factor m as a Function of Line Current

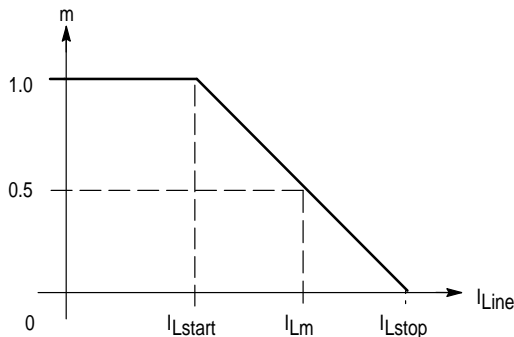

For low line currents below I_{Lstart} , thus long lines, the factor m equals 1. This means the hybrid network Z_{HL} is fully used. For high line currents above I_{Lstop} , thus short lines, the factor m equals 0. This means the hybrid network Z_{HS} is fully used. Both networks are used 50% for the intermediate line current I_{lm} .

The switch over between the 2 networks takes place in region 3 for the French and U.K. mask and in region 2 for the Low Voltage mask.

LINE LENGTH AGC

The TCA3388 offers the possibility to vary the transmit and receive gain over line length in order to compensate for the loss in gain at longer line lengths. In the block diagrams of the transmit and receive channels (Figures 9, 10) the line AGC is drawn. The line AGC can be switched off by connecting a 150 k Ω resistor between HSO and Gnd. In this case, the transmit and receive gain are lowered by 2.0 dB with respect to the value calculated in the formulas above.

The line AGC characteristics for both transmit and receive channel have the general shape depicted in Figure 12.

Figure 12. General Line AGC Characteristics

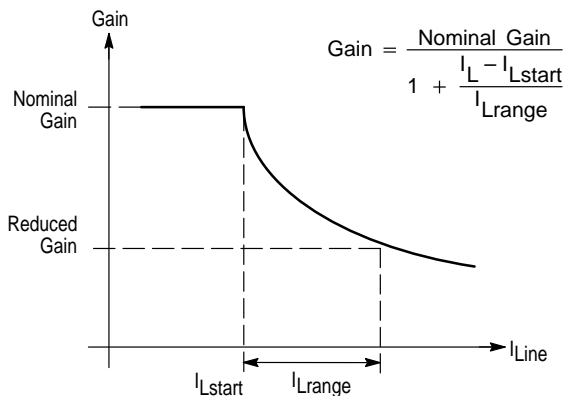

For low line currents, and thus long lines, the gains are nominal. When the line current has increased above I_{Lstart}

with a current I_{Lrange} , the gain is reduced by 6.0 dB. Due to the general characteristics of the line AGC curve, the gain will be decreased further for higher currents.

For France and U.K., the line AGC will be active in region 3 of the dc characteristics. The I_{Lstart} is approximately equal to the I_{LK} . The range is calculated from:

$$I_{Lrange} = \frac{Z1 \times (I2R - I2CD)}{R_{E3}}$$

For Low Voltage mask, the line AGC is active in region 2.

DIALING

Pulse-dialing is performed by making pin PI high. As a result the output LAO goes low and the loop will be disconnected. Internally the current consumption of the circuit is reduced and the current through the microphone is switched off.

DTMF-dialing is performed by supplying a DTMF signal current to Pin LAI. This is the same node where the microphone signal currents are internally applied. Therefore, for the DTMF gain the same formulas apply. Because the microphone preamplifier is bypassed, there is no influence on DTMF signals by the line length AGC.

A DTMF confidence tone can be generated on the earpiece by injecting a signal current at the RXI pin. Because only the earpiece amplifier itself is used, there are no effects from AGC or hybrid switchover.

For correct DTMF-dialing the pin MUT has to be made high. This mutes both the microphone and earphone preamplifier. In this way signals from the microphone will not be amplified to the line and signals from the line are not amplified to the earpiece.

The complete interfacing of the DTMF generator with the TCA3388 is shown in the typical application.

SUPPORT MATERIAL

Device Specification: Brief description of the TCA3388, block diagram, device data, test diagram, typical application

User manual TCA3388: Extended description of the circuit and its concept, adjustment procedure, application hints and proposals

Demonstration board: Shows performance of the TCA3388 in its basic application

TYPICAL APPLICATION

The typical application below is based on the demoboard of the TCA3388. It contains the speech transmission part, diode bridge, hook switch and microcontroller interfacing. The dc mask setting on the bottom left is given for France, U.K. and Low Voltage applications. The component values are given in the table of Figure 14. The line driver is extended with T1, D5 and R3 which increases the signal swing under low line voltage conditions.

TCA3388

Figure 13. Typical Application

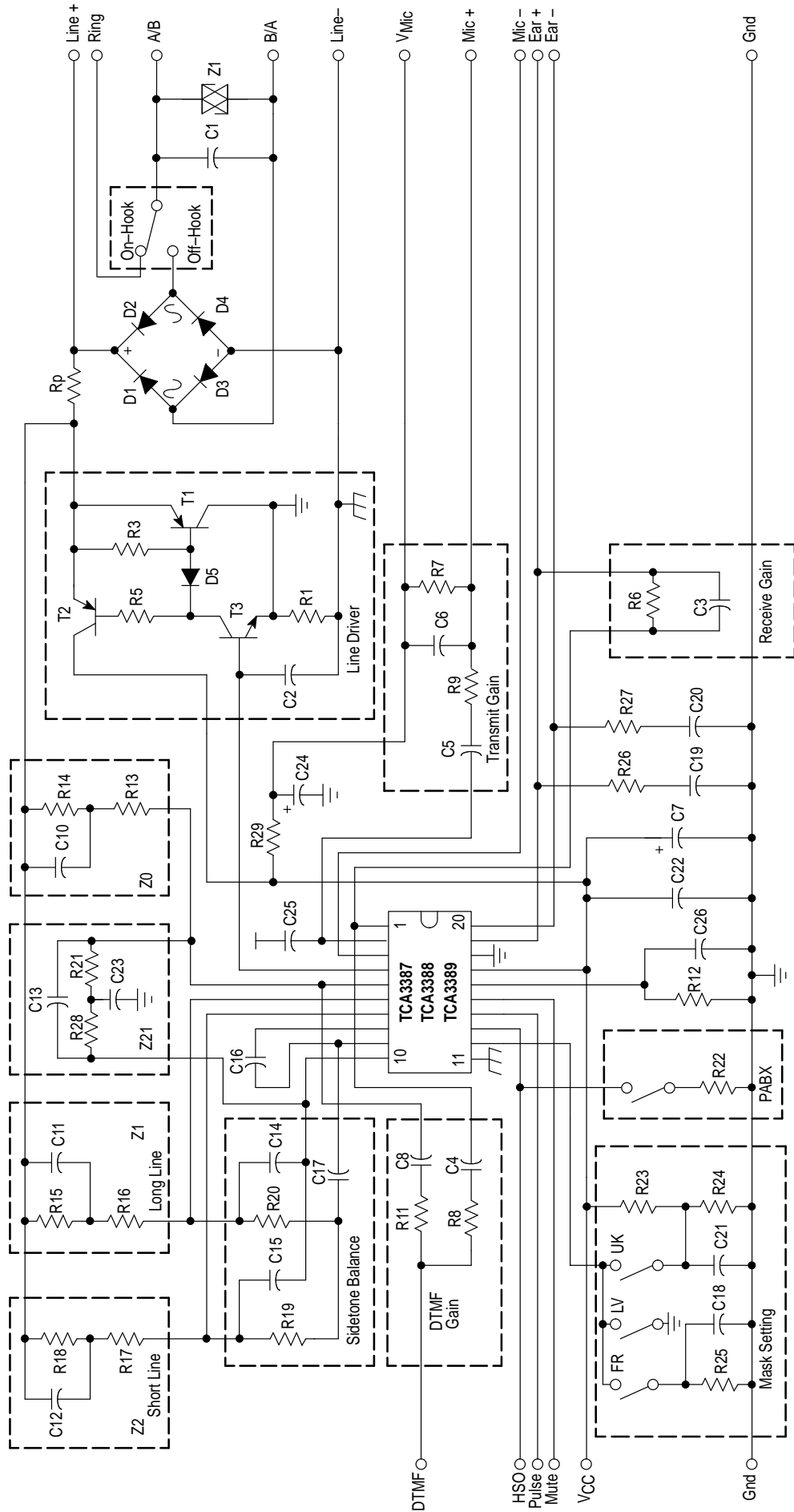

TCA3388

Figure 14. List of Components for Typical Application TCA3388

Item	Location on Board	Application			Remarks
		Basic L.V.	France	U.K.	
R1	Line Driver	16	16	18	
R3	Line Driver	10 k			
R5	Line Driver	1.0 k			
R6	Receive Gain	150 k			
R7	Transmit Gain	2.2 k			
R8	DTMF Gain	470 k			
R9	Transmit Gain	39 k			
R11	DTMF Gain	56 k			
R12	I_{ref} , Pin 16	121 k			1.0%
R13	Z0	580 k	560 k	330 k	
R14	Z0	–	680 k	620 k	
R15	Z1	620 k	1.2 m	1.8 m	
R16	Z1	130 k	300 k	330 k	
R17	Z2	–	620 k	820 k	
R18	Z2	–	820 k	1.5 m	
R19	Sidetone Bal	–	18 k	39 k	
R20	Sidetone Bal	7.5 k	15 k	22 k	
R21	Z21	16 k	16 k	18 k	
R22	PABX	150 k			
R23	Mask Setting	–	–	56 k	
R24	Mask Setting	–	–	47 k	
R25	Mask Setting	–	1.0 m	–	
R26	Pin 19	10			Stability
R27	Pin 20	10			Stability
R28	Z21	0			
R29	Transmit Gain	1.0 k			V_{Mic}
Rp	Line+	0	22	22	
C1	A/B	10 n			EMC
C2	Line Driver	470 p			
C3	Receive Gain	220 p			
C4	DTMF Gain	10 n			
C5	Transmit Gain	10 n			
C6	Transmit Gain	6.8 n			
C7	Pin 17	220 μ			V_{CC} , 10 V
C8	DTMF Gain	10 n			
C10	Z0	–	4.7 n	330 p	
C11	Z1	220 p	120 p	150 p	
C12	Z2	–	82 p	150 p	
C13	Z21	470 p			
C14	Sidetone Bal	470 p			Stability
C15	Sidetone Bal	–	470 p	470 p	Stability
C16	Pin 8	680 n	680 n	2.2 μ	DC Mask
C17	Sidetone Bal	680 n			

TCA3388

Figure 14. List of Components for Typical Application TCA3388

Item	Location on Board	Application			Remarks
		Basic L.V.	France	U.K.	
C18	Mask Setting	–	470 n	–	
C19	Pin 19	100 n			Stability
C20	Pin 20	100 n			Stability
C21	Mask Setting	–	–	10 μ	10 V
C22	Pin 17	100 n			Close to Pin
C23	Z21	–			
C24	Transmit Gain	10 μ			V _{Mic} , 10 V
C25	Pin 2	4.7 n			EMC
C26	Pin 16	1.0 n			EMC
T1	Line Driver	MPSA92			PNP–HV
T2	Line Driver	MJE350			PNP–HV
T3	Line Driver	MPSA42			NPN–HV
D1–D4	Bridge	4 x 1N4004			HV
D5	Line Driver	1N4004			Signal
Z1	A/B	MKP1V270			Sidac

TCA3388

OUTLINE DIMENSIONS

DP SUFFIX PLASTIC PACKAGE CASE 738-03 ISSUE E

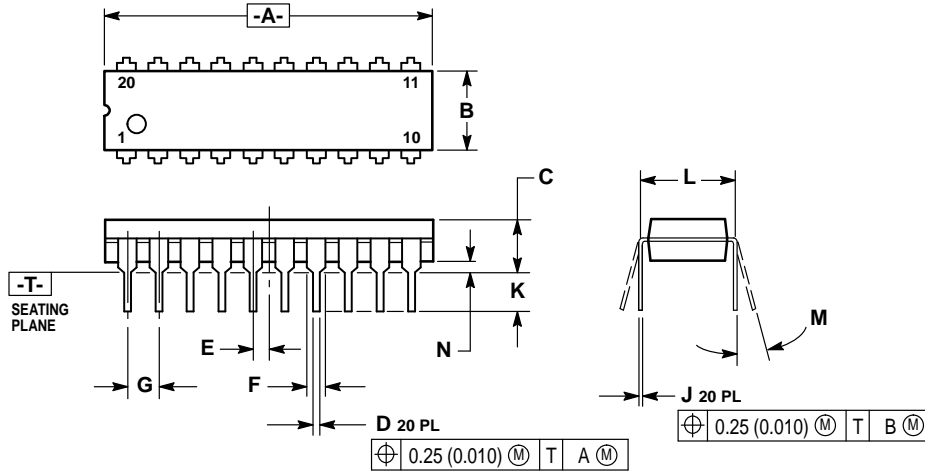

NOTES:

1. DIMENSIONING AND TOLERANCING PER ANSI Y14.5M, 1982.
2. CONTROLLING DIMENSION: INCH.
3. DIMENSION L TO CENTER OF LEAD WHEN FORMED PARALLEL.
4. DIMENSION B DOES NOT INCLUDE MOLD FLASH.

DIM	INCHES		MILLIMETERS	
	MIN	MAX	MIN	MAX
A	1.010	1.070	25.66	27.17
B	0.240	0.260	6.10	6.60
C	0.150	0.180	3.81	4.57
D	0.015	0.022	0.39	0.55
E	0.050 BSC		1.27 BSC	
F	0.050	0.070	1.27	1.77
G	0.100 BSC		2.54 BSC	
J	0.008	0.015	0.21	0.38
K	0.110	0.140	2.80	3.55
L	0.300 BSC		7.62 BSC	
M	0°	15°	0°	15°
N	0.020	0.040	0.51	1.01

FP SUFFIX PLASTIC PACKAGE CASE 751D-03 ISSUE E

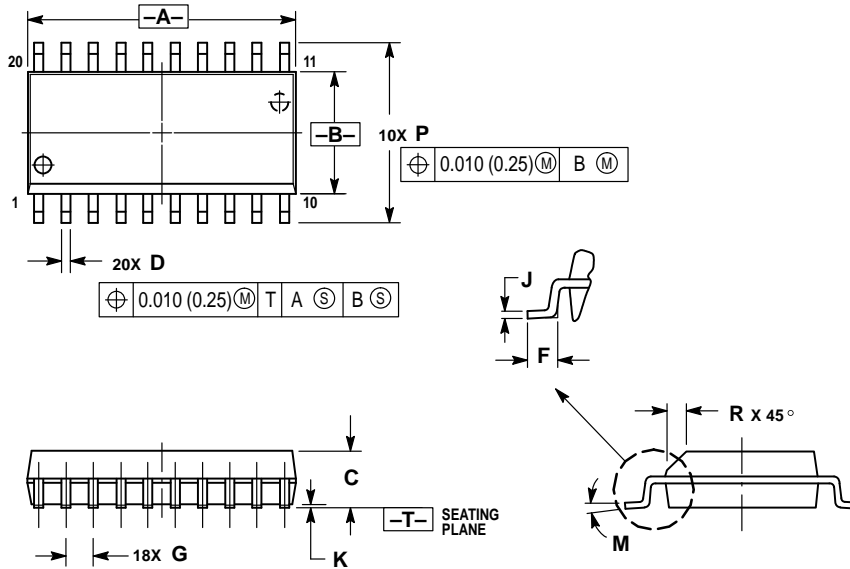

NOTES:

1. DIMENSIONING AND TOLERANCING PER ANSI Y14.5M, 1982.
2. CONTROLLING DIMENSION: MILLIMETER.
3. DIMENSIONS A AND B DO NOT INCLUDE MOLD PROTRUSION.
4. MAXIMUM MOLD PROTRUSION 0.150 (0.006) PER SIDE.
5. DIMENSION D DOES NOT INCLUDE DAMBAR PROTRUSION. ALLOWABLE DAMBAR PROTRUSION SHALL BE 0.13 (0.005) TOTAL IN EXCESS OF D DIMENSION AT MAXIMUM MATERIAL CONDITION.

DIM	MILLIMETERS		INCHES	
	MIN	MAX	MIN	MAX
A	12.65	12.95	0.499	0.510
B	7.40	7.60	0.292	0.299
C	2.35	2.65	0.093	0.104
D	0.35	0.49	0.014	0.019
F	0.50	0.90	0.020	0.035
G	1.27 BSC		0.050 BSC	
J	0.25	0.32	0.010	0.012
K	0.10	0.25	0.004	0.009
M	0°	7°	0°	7°
P	10.05	10.55	0.395	0.415
R	0.25	0.75	0.010	0.029

TCA3388

Motorola reserves the right to make changes without further notice to any products herein. Motorola makes no warranty, representation or guarantee regarding the suitability of its products for any particular purpose, nor does Motorola assume any liability arising out of the application or use of any product or circuit, and specifically disclaims any and all liability, including without limitation consequential or incidental damages. "Typical" parameters can and do vary in different applications. All operating parameters, including "Typicals" must be validated for each customer application by customer's technical experts. Motorola does not convey any license under its patent rights nor the rights of others. Motorola products are not designed, intended, or authorized for use as components in systems intended for surgical implant into the body, or other applications intended to support or sustain life, or for any other application in which the failure of the Motorola product could create a situation where personal injury or death may occur. Should Buyer purchase or use Motorola products for any such unintended or unauthorized application, Buyer shall indemnify and hold Motorola and its officers, employees, subsidiaries, affiliates, and distributors harmless against all claims, costs, damages, and expenses, and reasonable attorney fees arising out of, directly or indirectly, any claim of personal injury or death associated with such unintended or unauthorized use, even if such claim alleges that Motorola was negligent regarding the design or manufacture of the part. Motorola and  are registered trademarks of Motorola, Inc. Motorola, Inc. is an Equal Opportunity/Affirmative Action Employer.

How to reach us:

USA / EUROPE: Motorola Literature Distribution;
P.O. Box 20912; Phoenix, Arizona 85036. 1-800-441-2447

MFAX: RMFAX0@email.sps.mot.com – TOUCHTONE (602) 244-6609
INTERNET: <http://Design-NET.com>

JAPAN: Nippon Motorola Ltd.; Tatsumi-SPD-JLDC, Toshikatsu Otsuki,
6F Seibu-Butsuryu-Center, 3-14-2 Tatsumi Koto-Ku, Tokyo 135, Japan. 03-3521-8315

HONG KONG: Motorola Semiconductors H.K. Ltd.; 8B Tai Ping Industrial Park,
51 Ting Kok Road, Tai Po, N.T., Hong Kong. 852-26629298