

TOSHIBA

TCD2255D

TOSHIBA CCD LINEAR IMAGE SENSOR CCD (Charge Coupled Device)

TCD2255D

The TCD2255D is a high sensitive and low dark current 2700 elements×3 line CCD color image sensor which includes CCD drive circuit, clamp circuit and sample & hold circuit.

The sensor is designed for color image scanner. The device contains a row of 2700 elements×3 line photodiodes which provide a 12 lines/mm (300 DPI) across a A4 size paper. The device is operated by 5V pulse and 12V power supply.

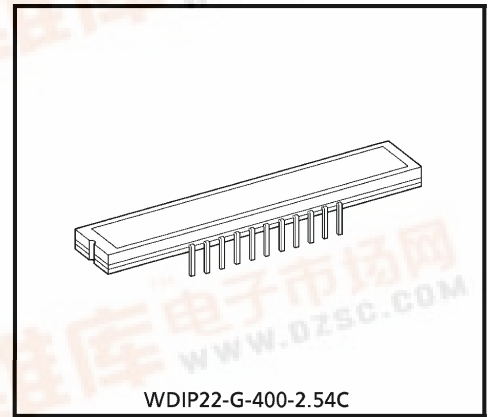

Weight : 4.5g (Typ.)

FEATURES

- Number of Image Sensing Elements : 2700 elements×3 line
- Image Sensing Element Size : 8μm by 8μm on 8μm centers
- Photo Sensing Region : High sensitive and low dark current PN photodiode
- Distanced Between Photodiode Array : 32μm (4 lines)
- Clock : 2 phase (5V)
- Power Supply : 12V Power supply voltage
- Internal Circuit : Sample & Hold circuit, Clamp circuit
- : Electric Shutter Function
- Package : 22 pin CERDIP package
- Color Filter : Red, Green, Blue

PIN CONNECTION

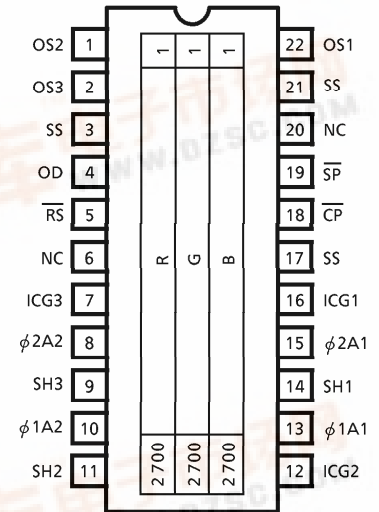

(TOP VIEW)

980910EBA1

● TOSHIBA is continually working to improve the quality and the reliability of its products. Nevertheless, semiconductor devices in general can malfunction or fail due to their inherent electrical sensitivity and vulnerability to physical stress. It is the responsibility of the buyer, when utilizing TOSHIBA products, to observe standards of safety, and to avoid situations in which a malfunction or failure of a TOSHIBA product could cause loss of human life, bodily injury or damage to property. In developing your designs, please ensure that TOSHIBA products are used within specified operating ranges as set forth in the most recent products specifications. Also, please keep in mind the precautions and conditions set forth in the TOSHIBA Semiconductor Reliability Handbook.

● The products described in this document are subject to the foreign exchange and foreign trade laws.

● The information contained herein is presented only as a guide for the applications of our products. No responsibility is assumed by TOSHIBA CORPORATION for any infringements of intellectual property or other rights of the third parties which may result from its use. No license is granted by implication or otherwise under any intellectual property or other rights of TOSHIBA CORPORATION or others.

● The information contained herein is subject to change without notice.



MAXIMUM RATINGS (Note 1)

CHARACTERISTIC	SYMBOL	RATING	UNIT
Clock Pulse Voltage	$V_{\phi A}$	-0.3~8.0	V
Shift Pulse Voltage	V_{SH}		
Reset Pulse Voltage	V_{RS}		
Clamp Pulse Voltage	V_{CP}		
Sample and Hold Pulse Voltage	V_{SP}		
Electrical Shutter Voltage	V_{ICG}		
Power Supply Voltage	V_{OD}	-0.3~15	V
Operating Temperature	T_{opr}	0~60	°C
Storage Temperature	T_{stg}	-25~85	°C

(Note 1) All voltage are with respect to SS terminals (Ground).

CIRCUIT DIAGRAM

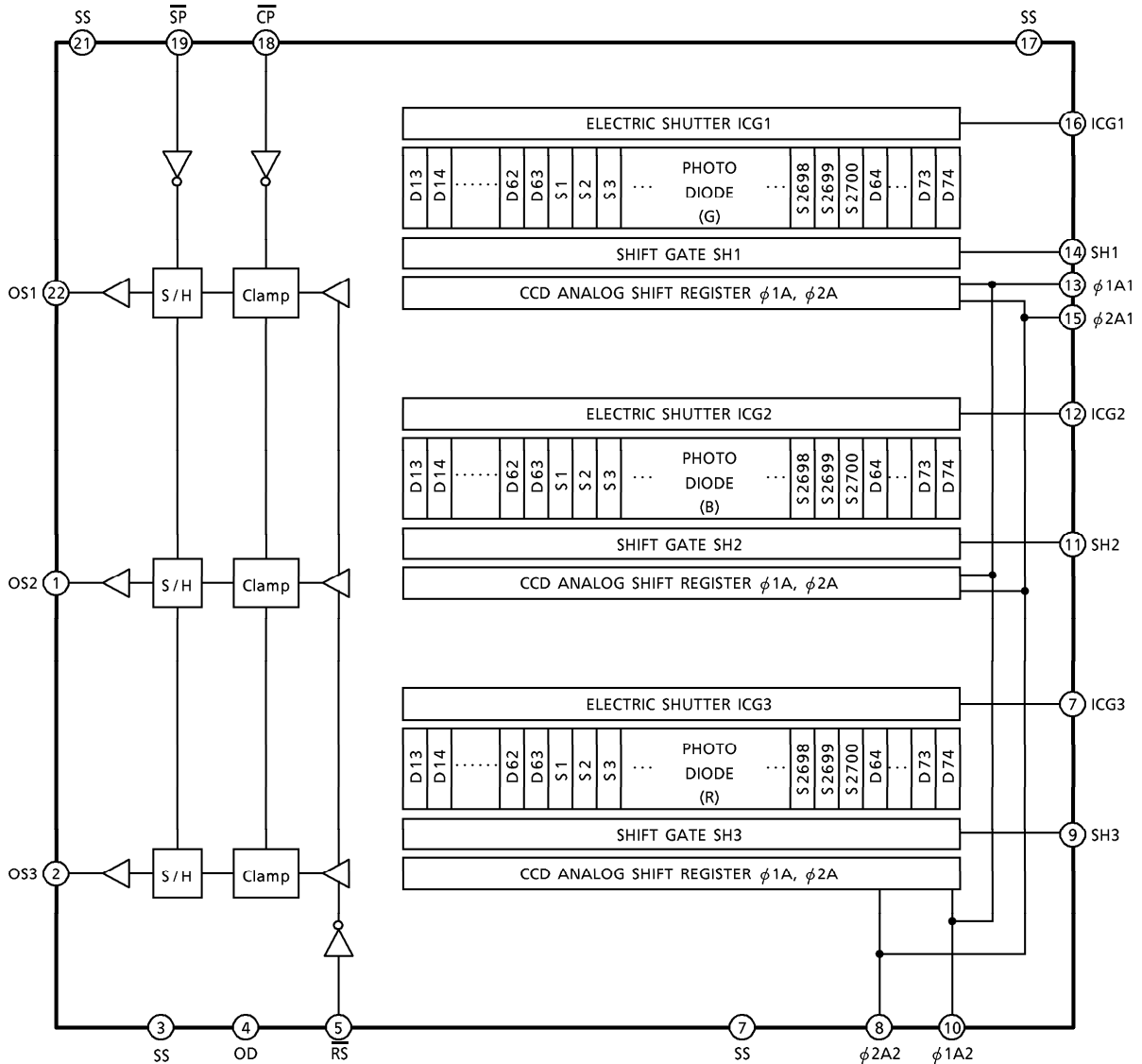

PIN NAMES

PIN No.	SYMBOL	NAME	PIN No.	SYMBOL	NAME
1	OS2	Signal Output 2 (Green)	22	OS1	Signal Output 1 (Blue)
2	OS3	Signal Output 3 (Red)	21	SS	Ground
3	SS	Ground	20	NC	Non Connection
4	OD	Power	19	\overline{SP}	Sample and Hold Gate
5	\overline{RS}	Reset Gate	18	\overline{CP}	Clamp Gate
6	NC	Non Connection	17	SS	Ground
7	ICG3	Electric Shatter Gate 3	16	ICG1	Electric Shatter Gate 1
8	$\phi 2A2$	Clock 2 (Phase 2)	15	$\phi 2A1$	Clock 1 (Phase 2)
9	SH3	Shift Gate 3	14	SH1	Shift Gate 1
10	$\phi 1A2$	Clock 2 (Phase 1)	13	$\phi 1A1$	Clock 1 (Phase 1)
11	SH2	Shift Gate 2	12	ICG2	Electric Shatter Gate 2

OPTICAL / ELECTRICAL CHARACTERISTICS

($T_a = 25^\circ\text{C}$, $V_{OD} = V_{DD} = 12\text{V}$, $V_\phi = V_{\overline{RS}} = V_{SH} = V_{\overline{CP}} = 5\text{V}$ (PULSE), $f_\phi = 1.0\text{MHz}$, $f_{\overline{RS}} = 1.0\text{MHz}$,
 LOAD RESISTANCE = $100\text{k}\Omega$, t_{INT} (INTEGRATION TIME) = 10ms ,
 LIGHT SOURCE = A LIGHT SOURCE + CM500S FILTER ($t = 1.0\text{mm}$)

CHARACTERISTIC	SYMBOL	MIN.	TYP.	MAX.	UNIT	NOTE
Sensitivity	R_R	9.1	13.0	16.9	V / (lx·s)	(Note 2)
	R_G	11.4	16.3	21.2		
	R_B	4.0	5.7	7.4		
Photo Response Non Uniformity	PRNU (1)	—	10	20	%	(Note 3)
	PRNU (3)	—	2.5	10	mV	(Note 4)
Image Lag	IL	—	0.01	—	%	(Note 5)
Saturation Output Voltage	V_{SAT}	1.7	2.0	—	V	(Note 6)
Saturation Exposure	SE	—	0.12	—	lx·s	(Note 7)
Dark Signal Voltage	V_{DRK}	—	3	9	mV	(Note 8)
Dark Signal Non Uniformity	DSNU	—	4	12	mV	(Note 8)
DC Power Dissipation	P_D	—	200	300	mW	
Total Transfer Efficiency	TTE	92	—	—	%	
Output Impedance	Z_o	—	0.4	1.0	$\text{k}\Omega$	
DC Signal Output Voltage	V_{OS}	3.0	5.0	7.0	V	(Note 9)
Random Noise	$N_{D\sigma}$	—	0.7	—	mV	(Note 10)
Reset Noise	V_{RS}	—	1.5	—	V	(Note 9)

(Note 2) Sensitivity is defined for each color of signal outputs average when the photosensitive surface is applied with the light of uniform illumination and uniform color temperature.

(Note 3) PRNU (1) is defined for each color on a single chip by the expressions below when the photosensitive surface is applied with the light of uniform illumination and uniform color temperature.

$$PRNU (1) = \frac{\Delta\bar{x}}{\bar{x}} \times 100 (\%)$$

When \bar{x} is average of total signal outputs and $\Delta\bar{x}$ is the maximum deviation from \bar{x} . The amount of incident light is shown below.

$$Red = \frac{1}{2} SE, Green = \frac{1}{2} SE, Blue = \frac{1}{4} SE$$

(Note 4) PRNU (3) is defined as maximum voltage with next pixel, where measured 5% of SE (Typ.).

(Note 5) Image Lag is defined as follows.

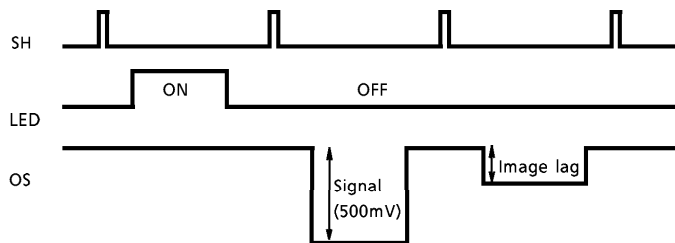

(Note 6) V_{SAT} is defined as minimum saturation output of all effective pixels.

(Note 7) Definition of SE : $SE = \frac{V_{SAT}}{R_G} (lx \cdot s)$

(Note 8) V_{DRK} is defined as average dark signal voltage of all effective pixels. DSNU is defined as different voltage between V_{DRK} and V_{MDK} when V_{MDK} is maximum dark signal voltage.

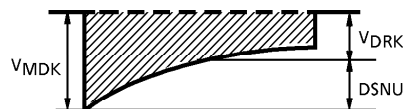

(Note 9) DC signal Output Voltage and Reset Noise is defined as follows, but Reset Noise is a fixed pattern noise.

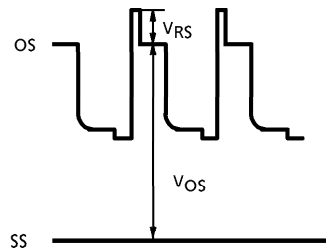

(Note 10) Random noise is defined as the standard deviation (sigma) of the output level difference between two adjacent effective pixels under no illumination (i.e. dark conditions) calculated by the following procedure.

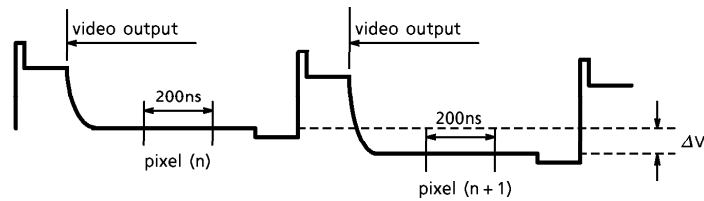

Output wave form (Effective pixels under dark condition)

- 1) Two adjacent pixels (pixel n and n + 1) in one reading are fixed as measurement points.
- 2) Each of the output level at video output periods averaged over 200ns period to get $V(n)$ and $V(n + 1)$.
- 3) $V(n + 1)$ is subtracted from $V(n)$ to get ΔV .

$$\Delta V = V(n) - V(n + 1)$$

- 4) The standard deviation of ΔV is calculated after procedure 2) and 3) are repeated 30 times (30 readings).

$$\Delta V = \frac{1}{30} \sum_{i=1}^{30} |\Delta V_i| \quad \sigma = \sqrt{\frac{1}{30} \sum_{i=1}^{30} (|\Delta V_i| - \overline{\Delta V})^2}$$

- 5) Procedure 2), 3) and 4) are repeated 10 times to get 10 sigma values.
- 6) 10 sigma values are averaged.

$$\overline{\sigma} = \frac{1}{10} \sum_{j=1}^{10} \sigma_j$$

- 7) $\overline{\sigma}$ value calculated using the above procedure is observed $\sqrt{2}$ times larger than that measured relative to the ground level. So we specify random noise as follows.

$$N_{D\sigma} = \frac{1}{\sqrt{2}} \overline{\sigma}$$

OPERATING CONDITION

CHARACTERISTIC		SYMBOL	MIN.	TYP.	MAX.	UNIT	NOTE
Clock Pulse Voltage	"H" Level	$V_{\phi A}$	4.7	5.0	5.5	V	
	"L" Level		0	0	0.05		
Shift Pulse Voltage	"H" Level	V_{SH}	$V_{\phi A} \text{ "H" } - 0.5$	$V_{\phi A} \text{ "H" }$	$V_{\phi A} \text{ "H" }$	V	(Note 11)
	"L" Level		0	0	0.3		
Reset Pulse Voltage	"H" Level	$\overline{V_{RS}}$	4.5	5.0	5.5	V	
	"L" Level		0	0	0.3		
Sample and Hold Pulse Voltage	"H" Level	$\overline{V_{SP}}$	4.5	5.0	5.5	V	(Note 12)
	"L" Level		0	0	0.3		
Clamp Pulse Voltage	"H" Level	$\overline{V_{CP}}$	4.5	5.0	5.5	V	
	"L" Level		0	0	0.3		
ICG Pulse Voltage	"H" Level	V_{ICG}	$V_{\phi A} \text{ "H" } - 0.5$	$V_{\phi A} \text{ "H" }$	$V_{\phi A} \text{ "H" }$	V	(Note 11)
	"L" Level		0	0	0.3		
Power Supply Voltage		V_{OD}	11.4	12.0	13.0	V	

(Note 11) $V_{\phi A} \text{ "H" }$ means the high level voltage of $V_{\phi A}$ when SH pulse is high level.

(Note 12) Supply "L" Level to \overline{SP} terminal when sample and hold circuitry is not used.

CLOCK CHARACTERISTICS (Ta = 25°C)

CHARACTERISTIC	SYMBOL	MIN.	TYP.	MAX.	UNIT
Clock Pulse Frequency	$f_{\phi A}$	—	1.0	5.0	MHz
Reset Pulse Frequency	$f_{\overline{RS}}$	—	1.0	5.0	MHz
Clamp Pulse Frequency	$f_{\overline{CP}}$	—	1.0	5.0	MHz
Sample and Hold Pulse Frequency	$f_{\overline{SP}}$	—	1.0	5.0	MHz
Clock Capacitance	$C_{\phi A}$	—	160	250	pF
Shift Gate Capacitance	C_{SH}	—	20	30	pF
Reset Gate Capacitance	$C_{\overline{RS}}$	—	20	30	pF
Sample and Hold Gate Capacitance	$C_{\overline{SP}}$	—	20	30	pF
Clamp Gate Capacitance	$C_{\overline{CP}}$	—	20	30	pF
ICG Gate Capacitance	C_{ICG}	—	20	30	pF

TIMING CHART (BIT CLAMP MODE)

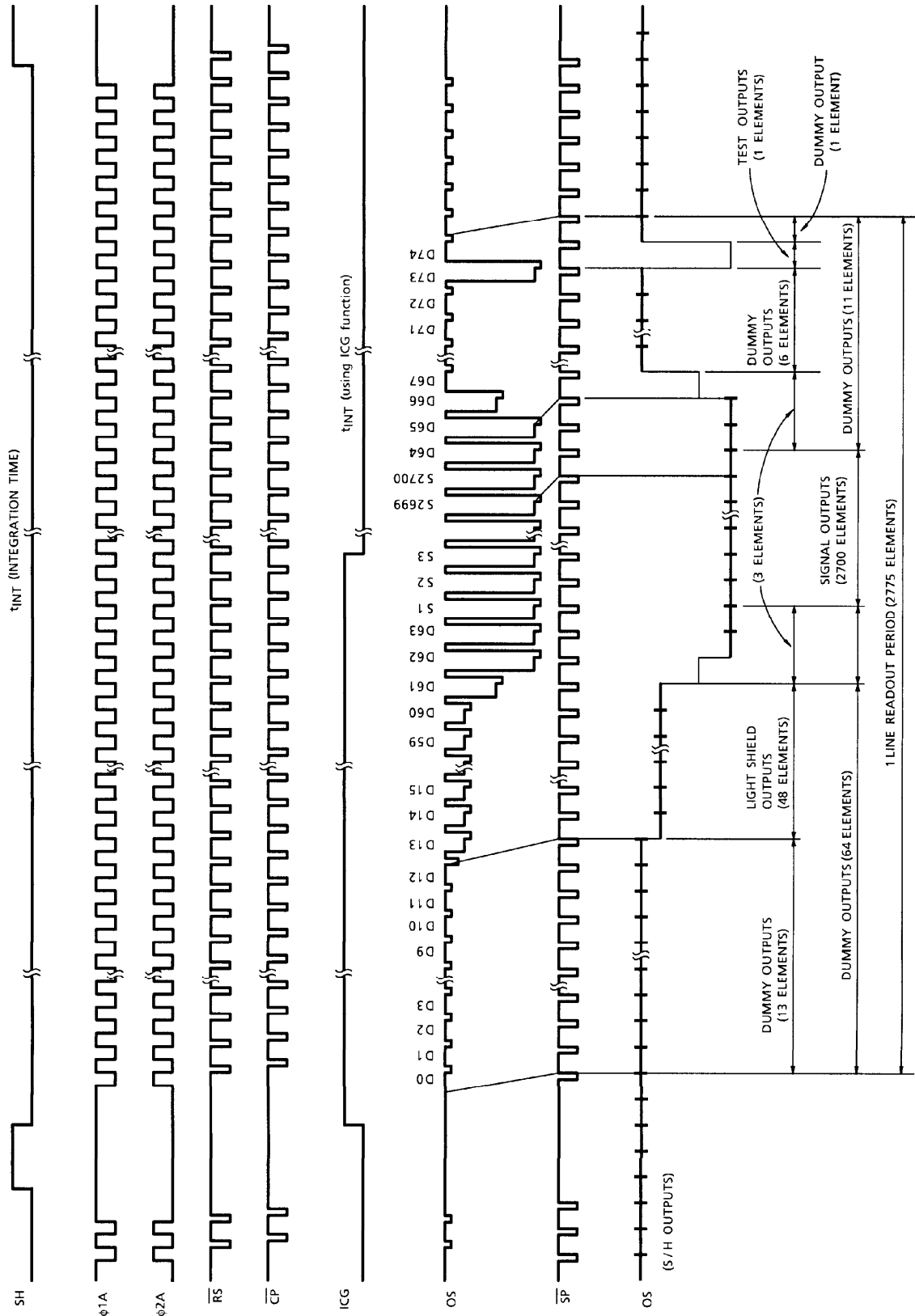

TIMING CHART (LINE CLAMP MODE)

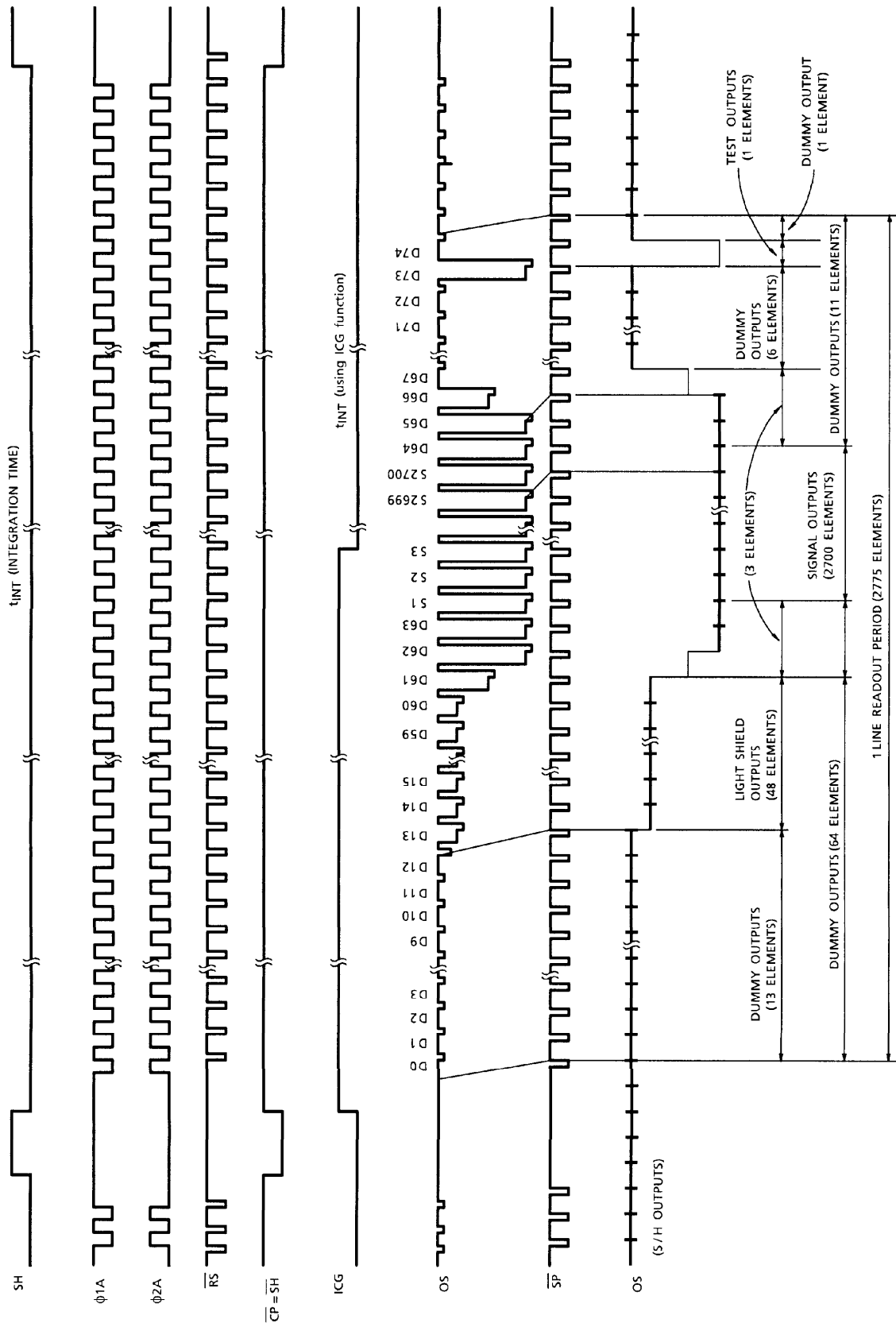

TIMING REQUIREMENTS (LINE CLAMP MODE)

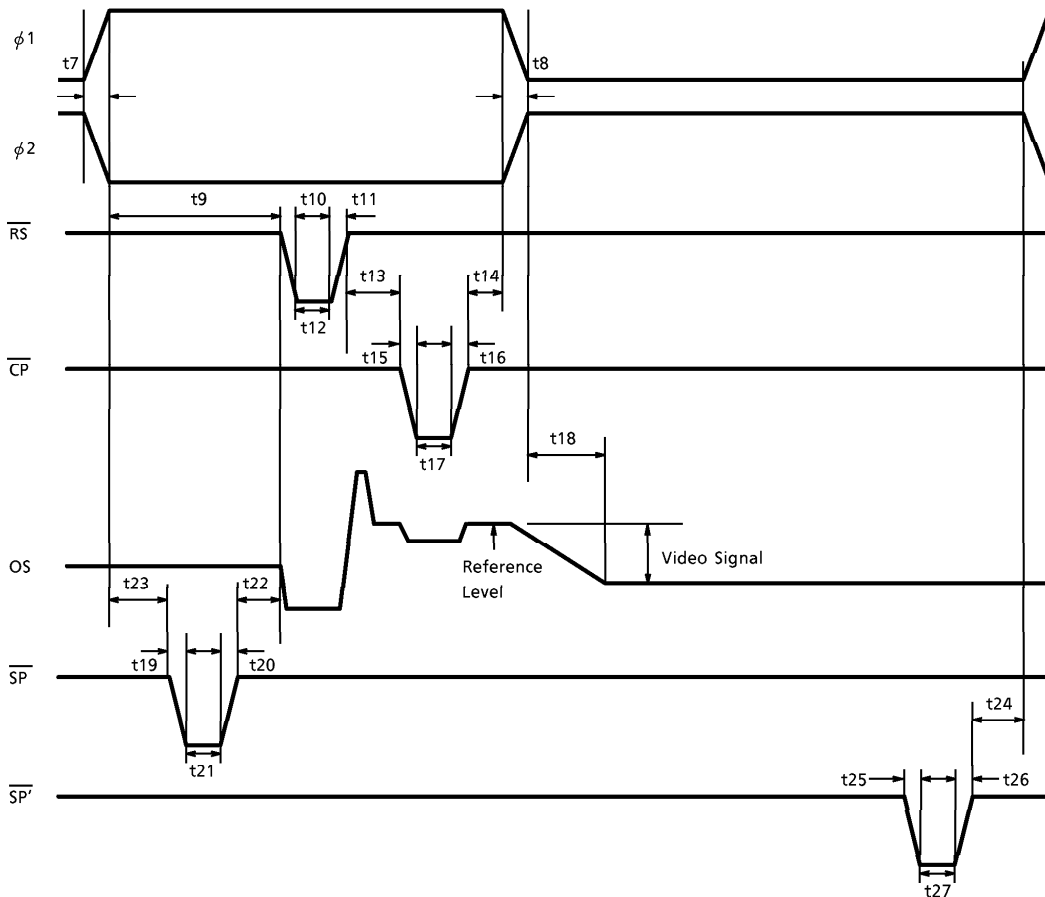
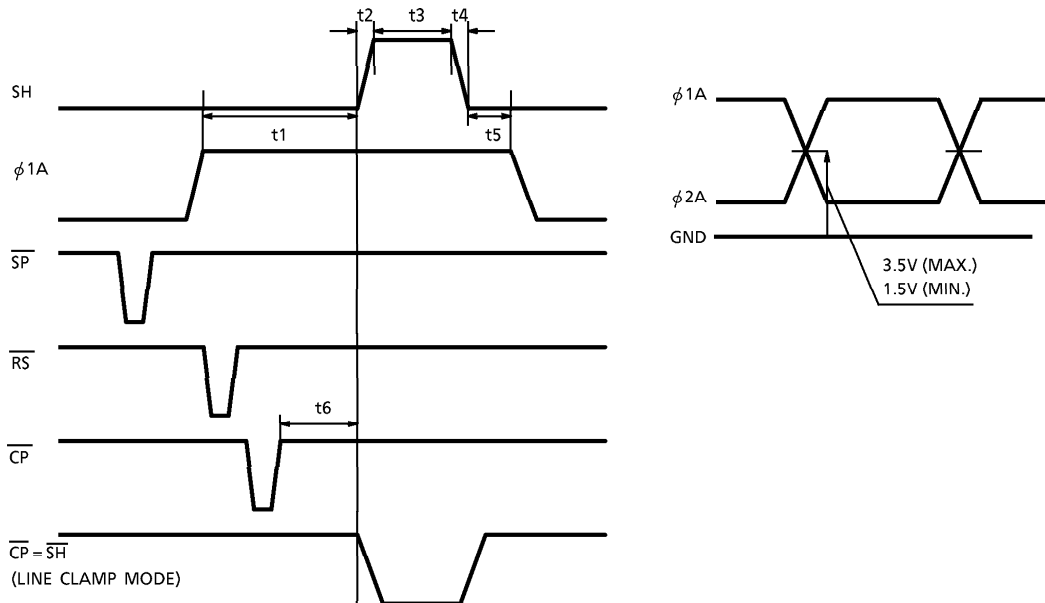

TIMING REQUIREMENTS (Cont.)

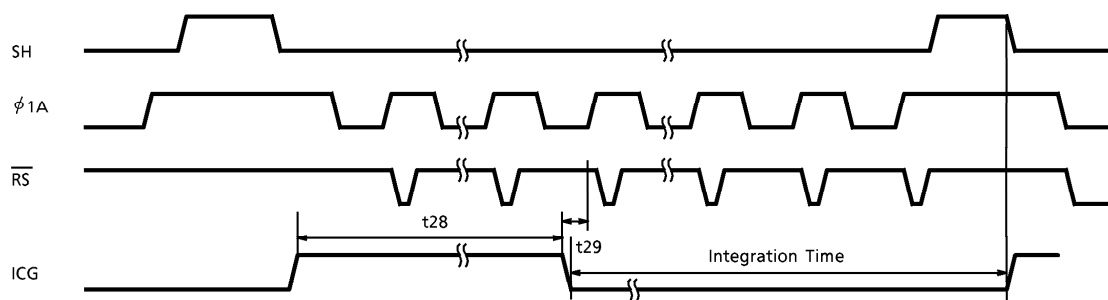

CHARACTERISTIC	SYMBOL	MIN.	TYP. (Note 13)	MAX.	UNIT
Pulse Timing of SH and $\phi 1$	t1	120	1000	—	ns
	t5	800	1000	—	
SH Pulse Rise Time, Fall Time	t2, t4	0	50	—	ns
SH Pulse Width	t3	3000	5000	—	ns
Pulse Timing of SH and \overline{CP}	t6	0	500	—	ns
$\phi 1$, $\phi 2$ Pulse Rise Time, Fall Time	t7, t8	0	20	—	ns
Pulse Timing of $\phi 1$ and \overline{RS}	t9	0	20	—	ns
\overline{RS} Pulse Rise Time, Fall Time	t10, t11	0	20	—	ns
\overline{RS} Pulse Width	t12	55	100	—	ns
Pulse Timing of \overline{RS} and \overline{CP}	t13	10	30	—	ns
Pulse Timing of \overline{CP} and $\phi 1$	t14	0	20	—	ns
\overline{CP} Pulse Rise Time, Fall Time	t15, t16	0	20	—	ns
\overline{CP} Pulse Width	t17	50	100	—	ns
Video Data Delay Time (Note 14)	t18	70	100	—	ns
\overline{SP} Pulse Rise Time, Fall Time	t19, t20, t25, t26	0	20	—	ns
\overline{SP} Pulse Width	t21, t27	50	100	—	ns
Pulse Timing of \overline{RS} and \overline{SP}	t22	0	20	—	ns
Pulse Timing of $\phi 1$ and \overline{SP}	t23, t24	0	20	—	ns
ICG Pulse Width	t18	5	—	—	μs
Pulse Timing of ICG and \overline{RS}	t29	0	20	—	ns

(Note 13) TYP. is the case of $f_{\overline{RS}} = 1.0\text{MHz}$.

(Note 14) Load Resistance is $100\text{k}\Omega$.

APPLICATION NOTE

	ON	OFF
Sample & Hold Function	\overline{SP} Pulse	$\overline{SP} = \text{Low}$
Electrical Shutter Function	ICG Pulse	ICG = Low

Clamp Mode Selection

Bit Clamp	\overline{CP} Pulse
Line Clamp	$\overline{CP} = \overline{SH}$

TYPICAL SPECTRAL RESPONSE / MODULATION TRANSFER FUNCTION

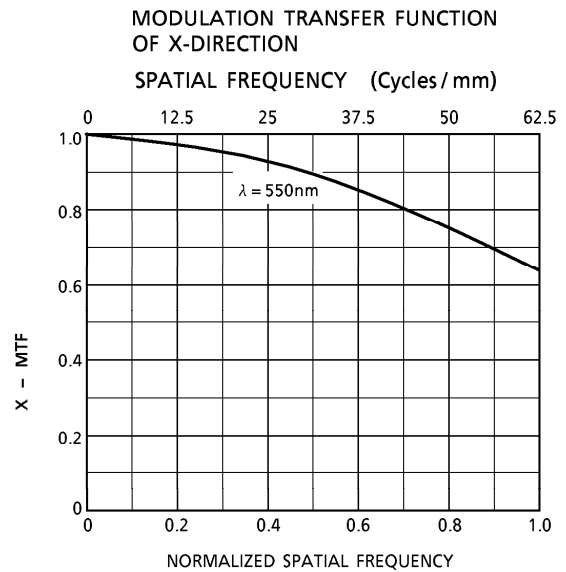
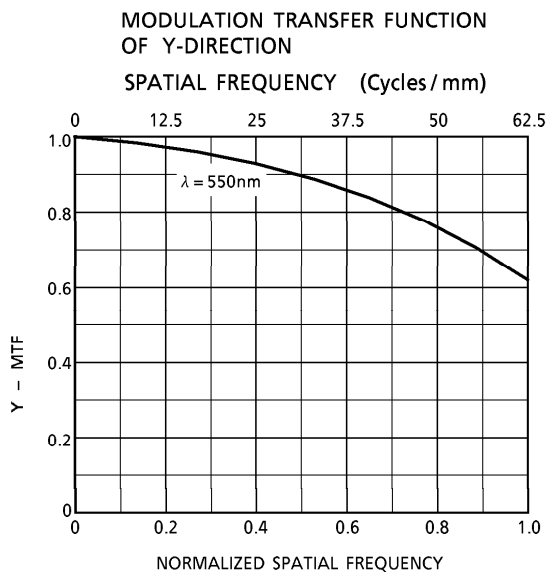
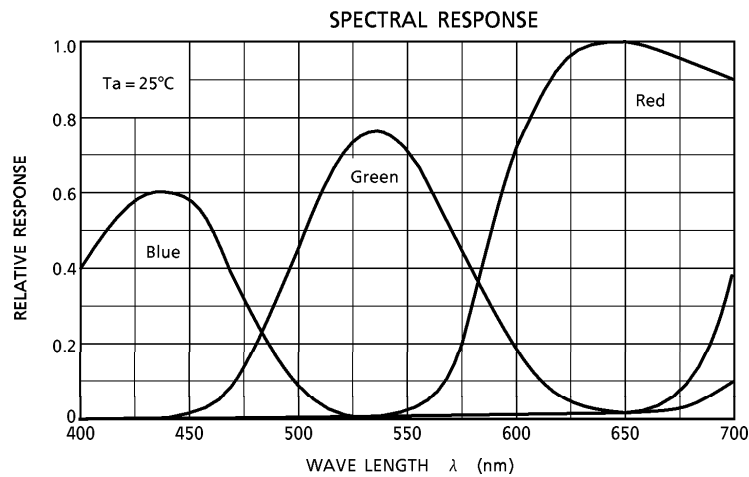

TYPICAL DRIVE CIRCUIT

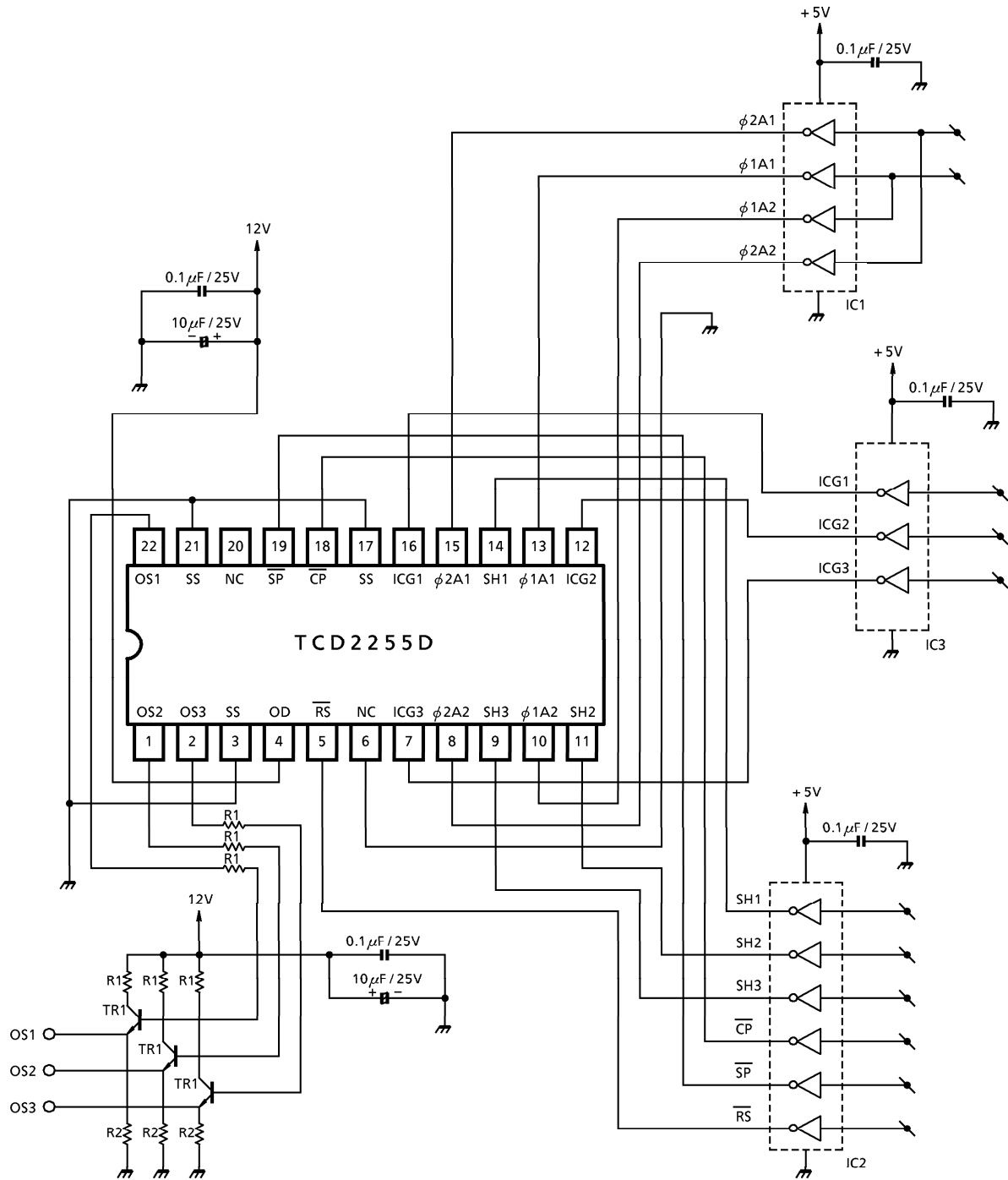

- IC1, 2, 3 : TC74HC04AP
- TR1 : 2SC1815-Y
- R1 : 150Ω
- R2 : 1500Ω

CAUTION**1. Window Glass**

The dust and stain on the glass window of the package degrade optical performance of CCD sensor.

Keep the glass window clean by saturating a cotton swab in alcohol and lightly wiping the surface, and allow the glass to dry, by blowing with filtered dry N₂.

Care should be taken to avoid mechanical or thermal shock because the glass window is easily to damage.

2. Electrostatic Breakdown

Store in shorting clip or in conductive foam to avoid electrostatic breakdown.

3. Incident Light

CCD sensor is sensitive to infrared light.

Note that infrared light component degrades resolution and PRNU of CCD sensor.

4. Lead Frame Forming

Since this package is not strong against mechanical stress, you should not reform the lead frame. We recommend to use a IC-inserter when you assemble to PCB.

OUTLINE DRAWING
WDIP22-G-400-2.54C

Unit : mm

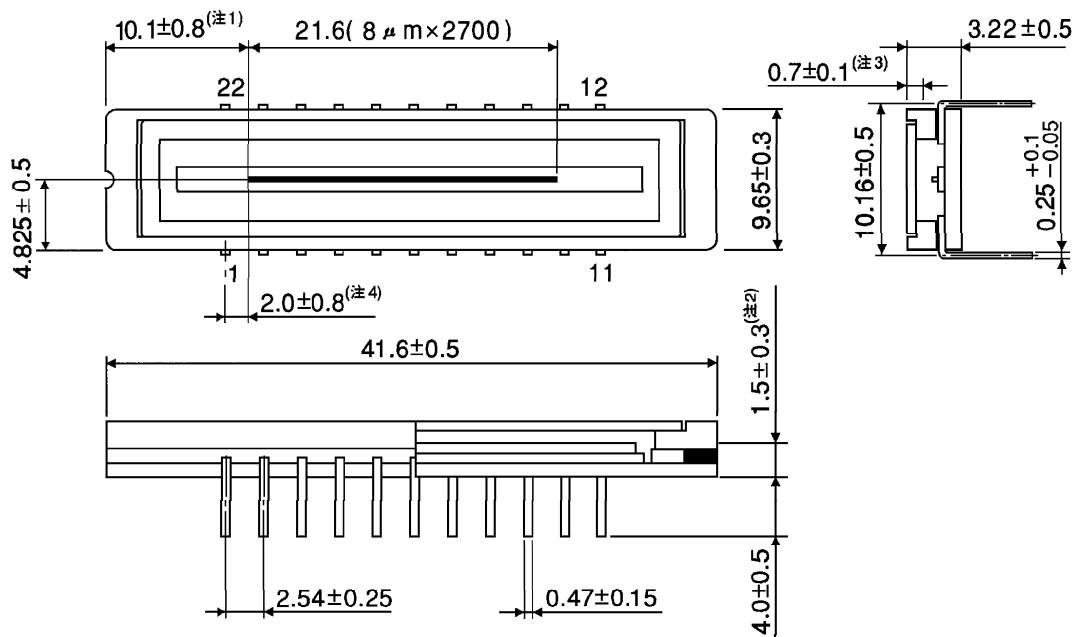

- (Note 1) No. 1 SENSOR ELEMENT (S1) TO EDGE OF PACKAGE.
- (Note 2) TOP OF CHIP TO BOTTOM OF PACKAGE.
- (Note 3) GLASS THICKNESS (n = 1.5)
- (Note 4) No. 1 SENSOR ELEMENT (S1) TO EDGE OF NO. 1 PIN.

Weight : 4.5g (Typ.)