



# TCMT1600 / TCMT4600

Vishay Semiconductors

## Optocoupler, Phototransistor Output, AC Input, Single/Quad Channel, Half Pitch Mini-Flat Package

### Features

- Low profile package (half pitch)
- AC Isolation test voltage 3750 V<sub>RMS</sub>
- Low coupling capacitance of typical 0.3 pF
- Low temperature coefficient of CTR
- Wide ambient temperature range
- Lead-free component
- Component in accordance to RoHS 2002/95/EC and WEEE 2002/96/EC

### Agency Approvals

- UL1577, File No. E76222 System Code M, Double Protection
- C-UL CSA 22.2 bulletin 5A, System Code U

### Applications

Programmable logic controllers

### Description

The low profile Miniflat package includes an Optocoupler with AC Input and Transistor Output. It is available in single channel (4 pin) TCMT1600 or quad channel (16 pin) TCMT4600.

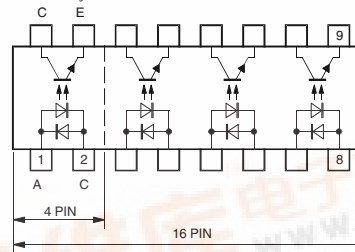
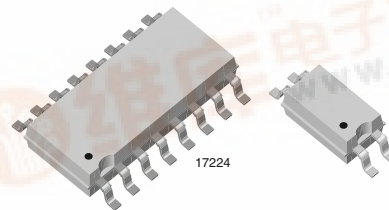

### Order Information

Part	Remarks
TCMT1600	CTR 80 - 300 %, Single Channel, SMD-4
TCMT4600	CTR 80 - 300 %, Quad Channel, SMD-16
TCMT4600T0*	CTR 80 - 300 %, Quad Channel, SMD-16

NOTE: Available only on tape and reel.

\* Product is rotated 180° in tape and reel cavity.

### Absolute Maximum Ratings

T<sub>amb</sub> = 25 °C, unless otherwise specified

Stresses in excess of the absolute Maximum Ratings can cause permanent damage to the device. Functional operation of the device is not implied at these or any other conditions in excess of those given in the operational sections of this document. Exposure to absolute Maximum Rating for extended periods of the time can adversely affect reliability.

### Input

Parameter	Test condition	Symbol	Value	Unit
Reverse voltage		V <sub>R</sub>	6	V
Forward current		I <sub>F</sub>	± 60	mA
Forward surge current	t <sub>p</sub> ≤ 10 μs	I <sub>FSM</sub>	± 1.5	A
Power dissipation		P <sub>diss</sub>	100	mW
Junction temperature		T <sub>j</sub>	125	°C



# TCMT1600 / TCMT4600



Vishay Semiconductors

## Output

Parameter	Test condition	Symbol	Value	Unit
Collector emitter voltage		$V_{CEO}$	70	V
Emitter collector voltage		$V_{ECO}$	7	V
Collector current		$I_C$	50	mA
Collector peak current	$t_p/T = 0.5, t_p \leq 10 \text{ ms}$	$I_{CM}$	100	mA
Power dissipation		$P_{diss}$	150	mW
Junction temperature		$T_j$	125	°C

## Coupler

Parameter	Test condition	Symbol	Value	Unit
AC isolation test voltage (RMS)		$V_{ISO}^{1)}$	3750	$V_{RMS}$
Total power dissipation		$P_{tot}$	250	mW
Operating ambient temperature range		$T_{amb}$	- 40 to + 100	°C
Storage temperature range		$T_{stg}$	- 40 to + 100	°C
Soldering temperature		$T_{sld}$	240	°C

<sup>1)</sup> Related to standard climate 23/50 DIN 50014

## Electrical Characteristics

$T_{amb} = 25 \text{ °C}$ , unless otherwise specified

Minimum and maximum values are testing requirements. Typical values are characteristics of the device and are the result of engineering evaluation. Typical values are for information only and are not part of the testing requirements.

## Input

Parameter	Test condition	Symbol	Min	Typ.	Max	Unit
Forward voltage	$I_F = 50 \text{ mA}$	$V_F$		1.25	1.6	V
Junction capacitance	$V_R = 0 \text{ V}, f = 1 \text{ MHz}$	$C_j$		50		pF

## Output

Parameter	Test condition	Symbol	Min	Typ.	Max	Unit
Collector emitter voltage	$I_C = 100 \text{ } \mu\text{A}$	$V_{CEO}$	70			V
Emitter collector voltage	$I_E = 100 \text{ } \mu\text{A}$	$V_{ECO}$	7			V
Collector dark current	$V_{CE} = 20 \text{ V}, I_F = 0, E = 0$	$I_{CEO}$			100	nA

## Coupler

Parameter	Test condition	Symbol	Min	Typ.	Max	Unit
Collector emitter saturation voltage	$I_F = 10 \text{ mA}, I_C = 1 \text{ mA}$	$V_{CEsat}$			0.3	V
Cut-off frequency	$I_F = 10 \text{ mA}, V_{CE} = 5 \text{ V}, R_L = 100 \text{ } \Omega$	$f_c$		100		kHz
Capacitance (input-output)	$f = 1 \text{ MHz}$	$C_{IO}$		0.3		pF

## Current Transfer Ratio

Parameter	Test condition	Part	Symbol	Min	Typ.	Max	Unit
$I_C/I_F$	$V_{CE} = 5\text{ V}, I_F = 5\text{ mA}$	TCMT1600	CTR	80		300	%
		TCMT4600	CTR	80		300	%

## Switching Characteristics

Parameter	Test condition	Symbol	Min	Typ.	Max	Unit
Delay time	$V_S = 5\text{ V}, I_C = 2\text{ mA}, R_L = 100\ \Omega$ (see figure 1)	$t_d$		3.0		$\mu\text{S}$
Rise time	$V_S = 5\text{ V}, I_C = 2\text{ mA}, R_L = 100\ \Omega$ (see figure 1)	$t_r$		3.0		$\mu\text{S}$
Fall time	$V_S = 5\text{ V}, I_C = 2\text{ mA}, R_L = 100\ \Omega$ (see figure 1)	$t_f$		4.7		$\mu\text{S}$
Storage time	$V_S = 5\text{ V}, I_C = 2\text{ mA}, R_L = 100\ \Omega$ (see figure 1)	$t_s$		0.3		$\mu\text{S}$
Turn-on time	$V_S = 5\text{ V}, I_C = 2\text{ mA}, R_L = 100\ \Omega$ (see figure 1)	$t_{on}$		6.0		$\mu\text{S}$
Turn-off time	$V_S = 5\text{ V}, I_C = 2\text{ mA}, R_L = 100\ \Omega$ (see figure 1)	$t_{off}$		5.0		$\mu\text{S}$
Turn-on time	$V_S = 5\text{ V}, I_F = 10\text{ mA}, R_L = 1\text{ k}\Omega$ (see figure 1)	$t_{on}$		9.0		$\mu\text{S}$
Turn-off time	$V_S = 5\text{ V}, I_F = 10\text{ mA}, R_L = 1\text{ k}\Omega$ (see figure 1)	$t_{off}$		18.0		$\mu\text{S}$

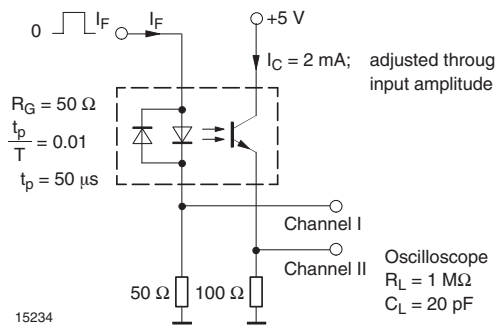

Figure 1. Test circuit, non-saturated operation

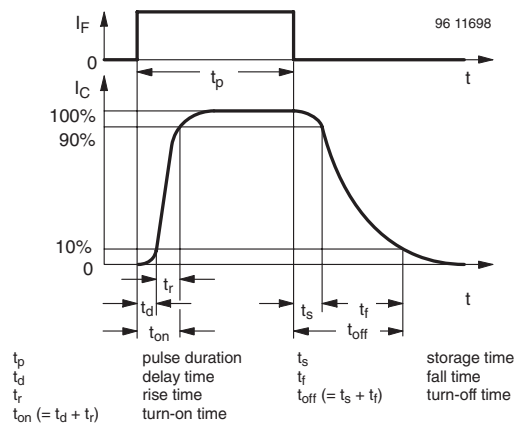

Figure 3. Switching Times

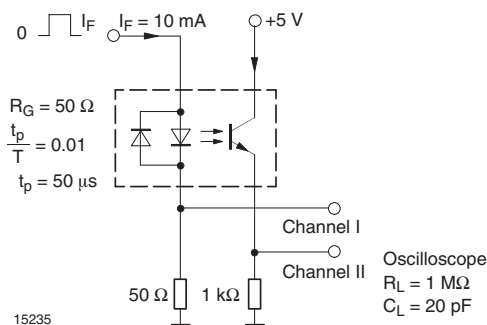

Figure 2. Test circuit, saturated operation

# TCMT1600 / TCMT4600



Vishay Semiconductors

## Typical Characteristics ( $T_{amb} = 25\text{ }^{\circ}\text{C}$ unless otherwise specified)

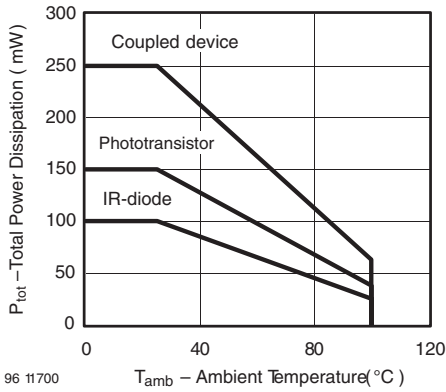

Figure 4. Total Power Dissipation vs. Ambient Temperature

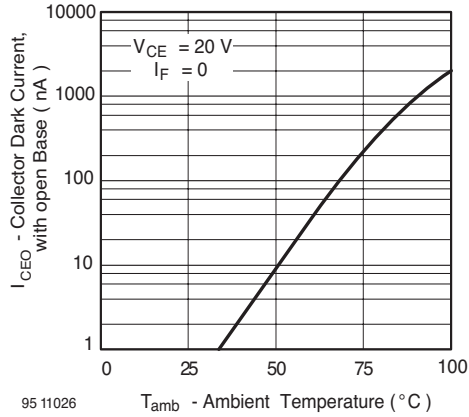

Figure 7. Collector Dark Current vs. Ambient Temperature

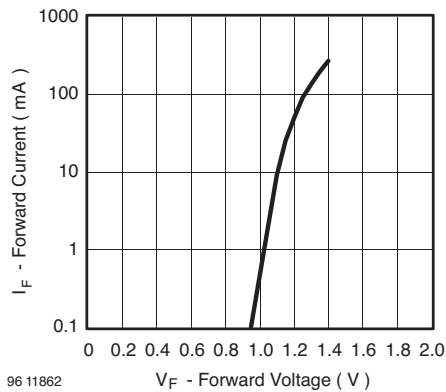

Figure 5. Forward Current vs. Forward Voltage

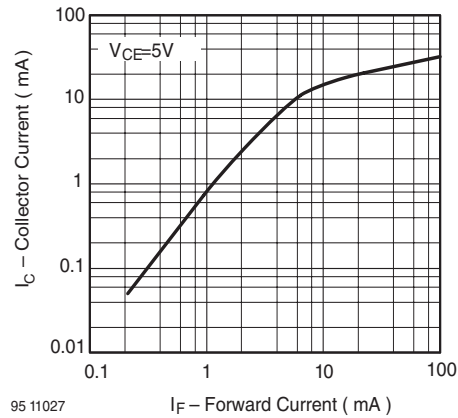

Figure 8. Collector Current vs. Forward Current

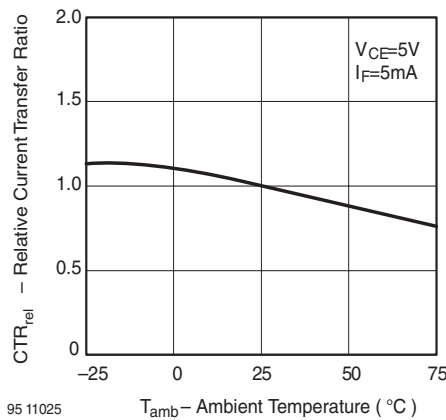

Figure 6. Relative Current Transfer Ratio vs. Ambient Temperature

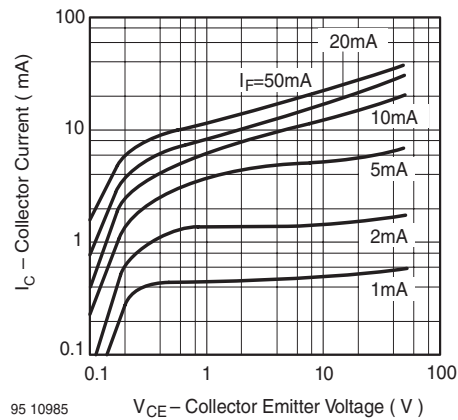

Figure 9. Collector Current vs. Collector Emitter Voltage



# TCMT1600 / TCMT4600

Vishay Semiconductors

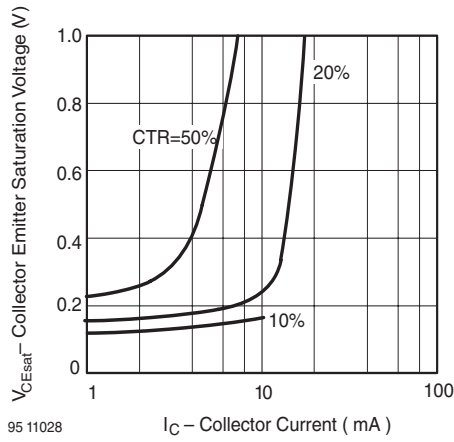

Figure 10. Collector Emitter Saturation Voltage vs. Collector Current

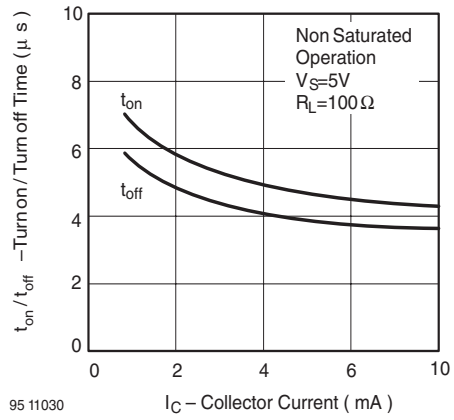

Figure 13. Turn on / off Time vs. Collector Current

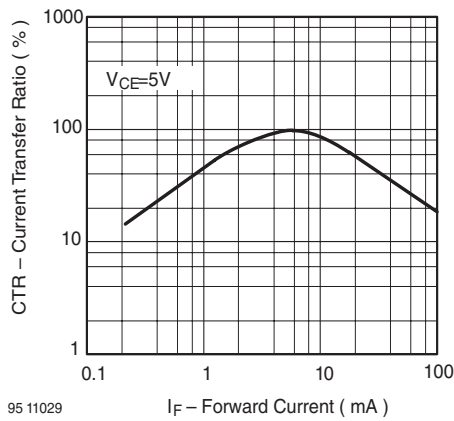

Figure 11. Current Transfer Ratio vs. Forward Current

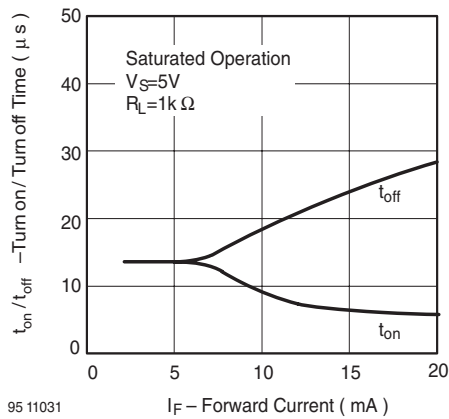

Figure 12. Turn on / off Time vs. Forward Current

# TCMT1600 / TCMT4600



Vishay Semiconductors

## Package Dimensions in mm

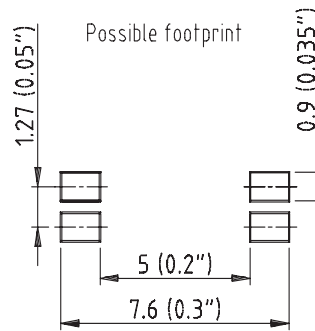
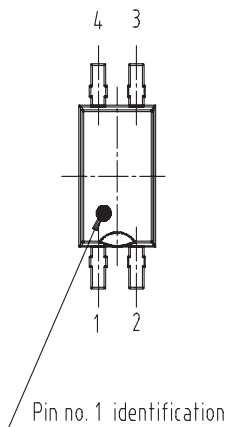
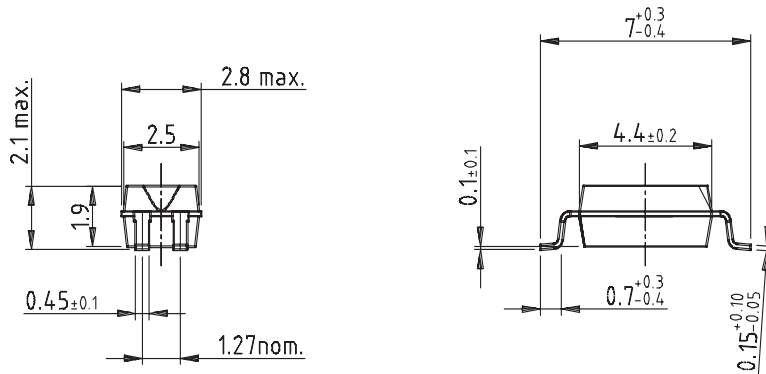

16283

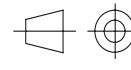



# TCMT1600 / TCMT4600

Vishay Semiconductors

## Package Dimensions in mm

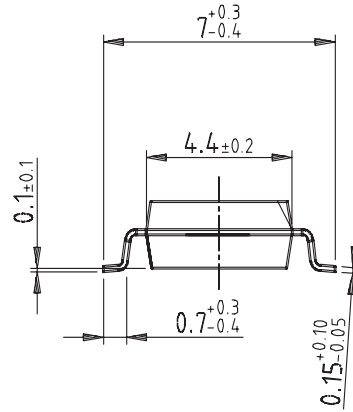
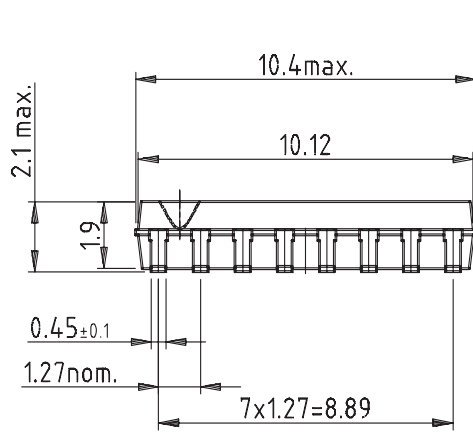

Possible footprint

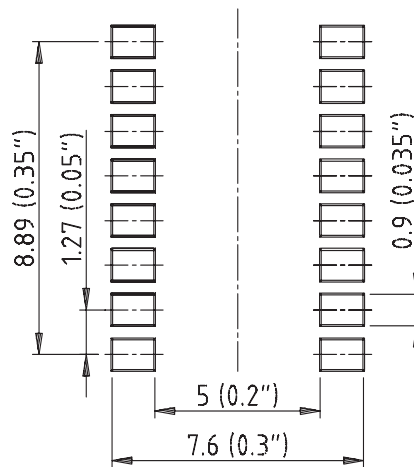
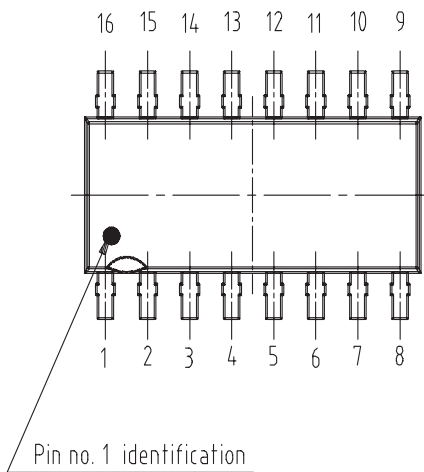

Drawing-No.: 6.544-5330.03-4

Issue: 1; 04.04.00

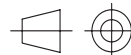

technical drawings  
according to DIN  
specifications

15226

### Ozone Depleting Substances Policy Statement

It is the policy of Vishay Semiconductor GmbH to

1. Meet all present and future national and international statutory requirements.
2. Regularly and continuously improve the performance of our products, processes, distribution and operating systems with respect to their impact on the health and safety of our employees and the public, as well as their impact on the environment.

It is particular concern to control or eliminate releases of those substances into the atmosphere which are known as ozone depleting substances (ODSs).

The Montreal Protocol (1987) and its London Amendments (1990) intend to severely restrict the use of ODSs and forbid their use within the next ten years. Various national and international initiatives are pressing for an earlier ban on these substances.

Vishay Semiconductor GmbH has been able to use its policy of continuous improvements to eliminate the use of ODSs listed in the following documents.

1. Annex A, B and list of transitional substances of the Montreal Protocol and the London Amendments respectively
2. Class I and II ozone depleting substances in the Clean Air Act Amendments of 1990 by the Environmental Protection Agency (EPA) in the USA
3. Council Decision 88/540/EEC and 91/690/EEC Annex A, B and C (transitional substances) respectively.

Vishay Semiconductor GmbH can certify that our semiconductors are not manufactured with ozone depleting substances and do not contain such substances.

We reserve the right to make changes to improve technical design  
and may do so without further notice.

Parameters can vary in different applications. All operating parameters must be validated for each customer application by the customer. Should the buyer use Vishay Semiconductors products for any unintended or unauthorized application, the buyer shall indemnify Vishay Semiconductors against all claims, costs, damages, and expenses, arising out of, directly or indirectly, any claim of personal damage, injury or death associated with such unintended or unauthorized use.

Vishay Semiconductor GmbH, P.O.B. 3535, D-74025 Heilbronn, Germany  
Telephone: 49 (0)7131 67 2831, Fax number: 49 (0)7131 67 2423