

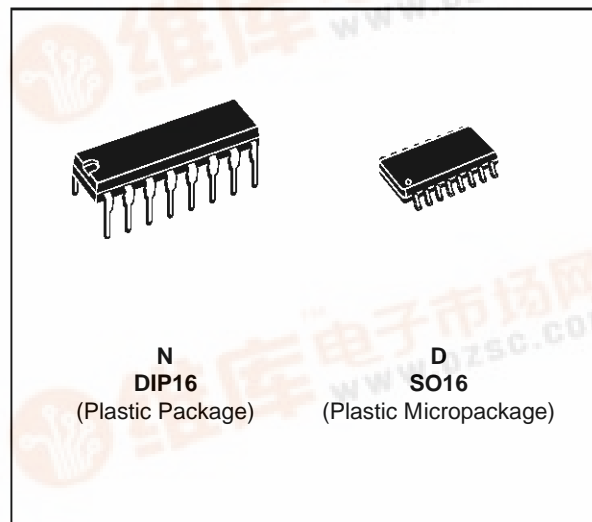

TD310

TRIPLE IGBT/MOS DRIVER

- THREE POWER IGBT/MOS AND PULSE TRANSFORMER DRIVERS
- CURRENT SENSE COMPARATOR WITH 1ms INHIBITION TIME FUNCTION
- INSTANTANEOUS SIGNAL TRANSMISSION
- 0.6 Amp PER CHANNEL PEAK OUTPUT CURRENT CAPABILITY
- LOW OUTPUT IMPEDANCE TYP : 7Ω at 200mA
- CMOS/LSTTL COMPATIBLE INVERTING INPUT WITH HYSTERESIS
- 4V TO 16V SINGLE SUPPLY OPERATION
- CURRENT AMPLIFIER
- LOW BIAS CURRENT TYP : 1.5mA
- ADJUSTABLE UNDERVOLTAGE LOCKOUT LEVEL
- STAND-BY MODE
- DURING POWER UP NO RANDOM OUTPUT STATE
- ENHANCED LATCH-UP IMMUNITY
- CHANNEL PARALLELING CAPABILITY



ORDER CODES

Part Number	Temperature Range	Package	
		N	D
TD310I	-40°C, +125°C	•	•

DESCRIPTION

The TD310 is designed to drive one, two or three Power IGBT/MOS and has driving capability for pulse transformer. So it is perfectly suited to interface control IC with Power Switches in low side or half-bridge configuration.

The typical application shown figure 1 implements the TD310 in a pulse controlled half-bridge drive. Positive and negative pulses are applied to the pulse transformer to charge and discharge the IGBT/MOS gate capacitance. More sophisticated secondary circuits provide low impedance gate drive and short-circuit protection as shown in application note n° AN461.

On Figure 2, TD310 is implemented as a low side driver in a typical 3 phase motor drive.

Figure 3 presents a general purpose low side gate drive.

In both case, the current amplifier provides interfacing between a sense resistor and an A/D converter.

PIN CONNECTIONS

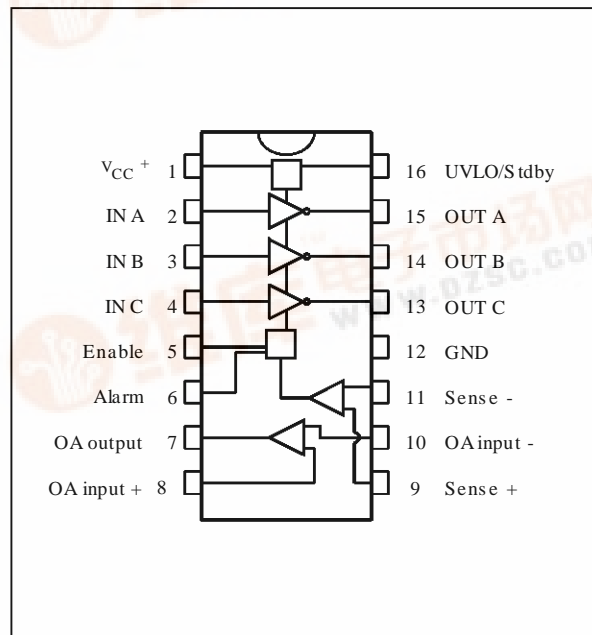

TD310

BLOCK DIAGRAM

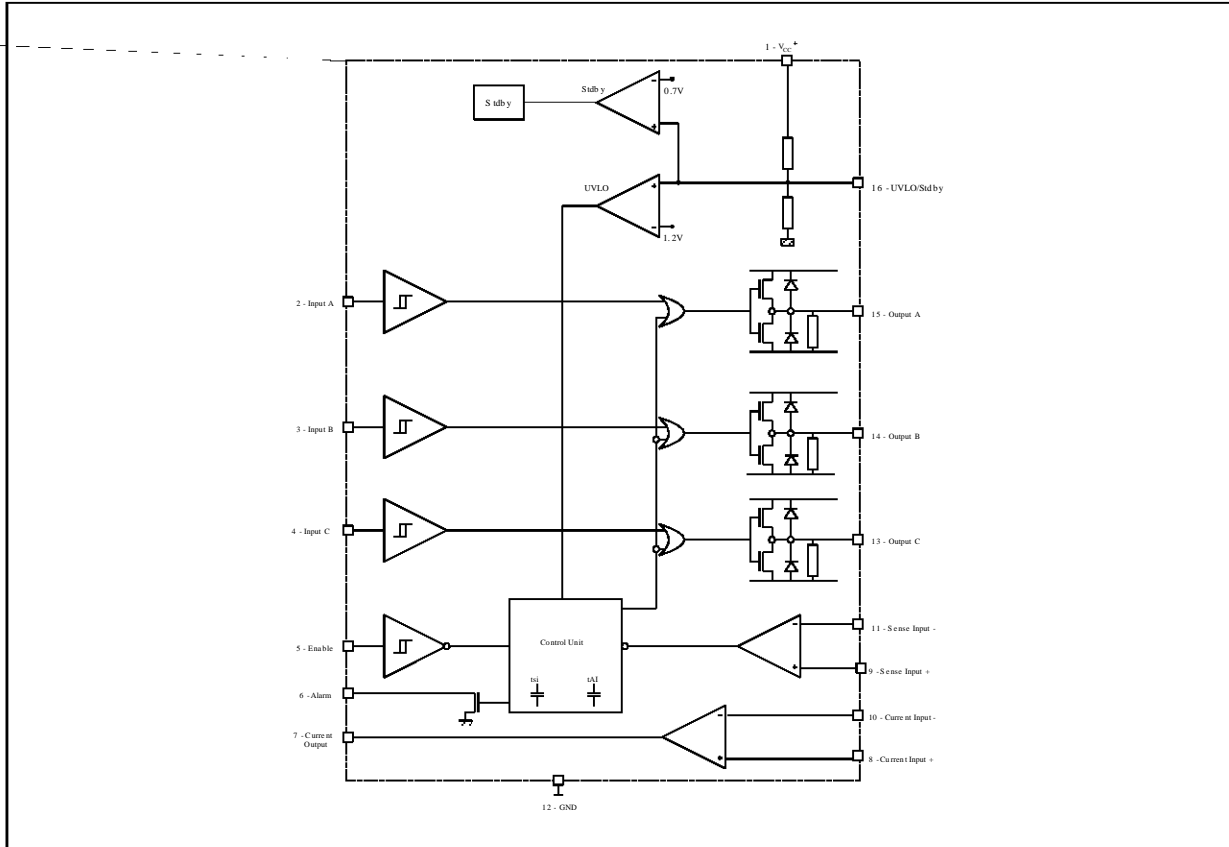

ABSOLUTE MAXIMUM RATINGS

Symbol	Parameter	Value	Unit
V_{CC}	Supply Voltage	18	V
V_i	Input Voltage	0 to V_{CC}	V
V_{is}	Sense Input Voltage	-0.3 to V_{CC}	V
T_j	Junction Temperature	-40 to 150	°C
T_{amb}	Ambient Temperature	-40 to 125	°C

OPERATING CONDITIONS

Symbol	Parameter	Value	Unit
V_{CC}	Supply Voltage	4 to 16	V

INSTRUCTIONS FOR USE

- 1 - The TD310 supply voltage must be decoupled with a 1µF min. capacitor.
- 2 - If the application involving TD310 requires maximum output current capability, this current must be pulsed : pulse width 1µsec, duty cycle 1% at T_{amb} .

ELECTRICAL CHARACTERISTICSV_{CC} = 15V, T_{amb} = 25°C (unless otherwise specified)

Symbol	Parameter	Min.	Typ.	Max.	Unit
I _{CC}	Supply Current with Inputs in High State		1.5	2	mA
LOGIC INPUT (all inputs)					
V _{IH}	High Input Voltage	2			V
V _{IL}	Low Input Voltage			0.8	V
I _{IH}	High Input Current		10		pA
I _{IL}	Low Input Current		10		pA
t _{dH} , t _{eH} t _{dL} , t _{eL}	Propagation Delay (10% input to 10% output) Output Rise Output Fall T _{min.} ≤ T _{amb} ≤ T _{max.}		200 60	400 400	ns
t _{ii}	Input Inhibiting Time		100		ns
t _{dd}	Differential Delay Time Between Channels		20		ns
OUTPUT DRIVERS					
V _{sod}	Sourcing Drop Voltage (A/B/C outputs) I _{source} = 200mA			3	V
V _{sid}	Sinking Drop Voltage (A/B/C outputs) I _{sink} = 200mA			5	V
V _{dem}	Demagnetising Drop Voltage (A/B/C outputs) I _{demag.} = 100mA			2	V
R _{opd}	Output Pull Down Resistor		47		kΩ
ALARM OUTPUT					
I _s	Low Level Sinking Current V _O = 0.8V	5	35		mA
I _{sh}	High Level Sinking Current			1	μA
t _A	Alarm Output : Delay Time to Alarm Fall if Sense Input Triggered			500	ns
SENSE INPUT					
V _{ios}	Input Offset Voltage			20	mV
t _{Ai}	Inhibition Time if Sense Input Triggered		1		ms
t _s	Delay Time to Output Fall if Sense Input Triggered All outputs inhibited			600	ns
t _{si}	Inhibition Time of Sense Input		300		ns
V _{shys}	Sense Hysteresis		40		mV
OPERATIONAL AMPLIFIER					
V _{icm}	Common Mode Input Voltage Range	0 to V _{CC} ⁺ -1.5			V
V _{io}	Input Offset Voltage			10	mV
GBP	Gain Bandwidth Product		1		MHz
A _{vd}	Open Loop Gain	60			dB
SR	Slew Rate at Unity Gain R _L = 100kΩ, C _L = 100pF, V _i = 3 to 7V		0.6		V/μs
STAND-BY					
V _{stdby}	Standby Mode Threshold Voltage	0.3		1.1	V
I _{stdby}	Standby Mode Supply Current		30		μA
UNDER VOLTAGE LOCKOUT					
I _{adj}	Under Voltage Level Adjust Current		1		μA/V
V _{st1}	Internal Stop Threshold (without external adjustment)	10.7		13.3	V
V _{hys}	Threshold Hysteresis		0.8		V

TD310

UVLO/stbdy pin functioning modes

Due to the wide supply voltage range of the TD310, the UVLO function (Under Voltage Lock Out) is externally adjustable by a resistor bridge.

The bridge rate can be calculated in relation with the expected UVLO protection level as follows :

$$V_{UVLO} \times \frac{R1}{R1+R2} = 1.2V \text{ (where R1 is the lower resistor of the bridge)}$$

The internal resistor sets the default UVLO value to 12V (*) and might influence the external bridge rate if the values of the external resistors are too high.

The standby threshold value depends of the UVLO value as follows :

$$V_{stdby} = 0.7/1.2 V_{UVLO}$$

Both UVLO and stbdy functions can be inhibited by connecting the UVLO/stbdy pin to V_{CC}^+ via a pull up resistor (ex 150k Ω).

The following table summarizes the functions of the TD310 :

	Pin	16	9/11	5	2/3/4	15/14 /13	6	7/8/10	
	Configuration	UVLO/stbdy	Sense+/Sense-	Enable	In A/B/C	Out A/B/C	Alarm	Op. Amp.	Consumption
Normal	1	H	+ > -	X	X	L	L	OK	H (1.5mA)
			+ < -	H	IN	\overline{IN}	H		
Stbdy	2	L	+ > -	X	X	L	L	HZ	L (30 μ A)
			+ < -				H		
UVLO	3	M	X	X	X	L	L	OK	H

Configuration 1 : UVLO/stbdy = H

The TD310 is in a normal consumption state (1.5mA), the operational amplifier is normally functioning and the buffer outputs are determined by the sense comparator inputs, the enable inputs and the buffer inputs.

Configuration 2 : UVLO/stbdy = L

The TD310 is in a low consumption state (standby mode 30 μ A), the buffer outputs are set to low state and the operational amplifier is in high impedance state.

Configuration 3 : UVLO/stbdy = M

The V_{CC} supply voltage is between V_{UVLO} and V_{stdby} (**). The TD310 remains in a normal consumption state and the operational amplifier is normally functioning but the buffer outputs and the alarm pin are set to low state.

(*) If the UVLO level remains unadjusted, it is recommended to bypass the UVLO/stbdy pin with a 1nF capacitor.

(**) If the supply voltage falls below V_{stdby} , the TD310 is set in standby mode (configuration 2).

TIMING DIAGRAM

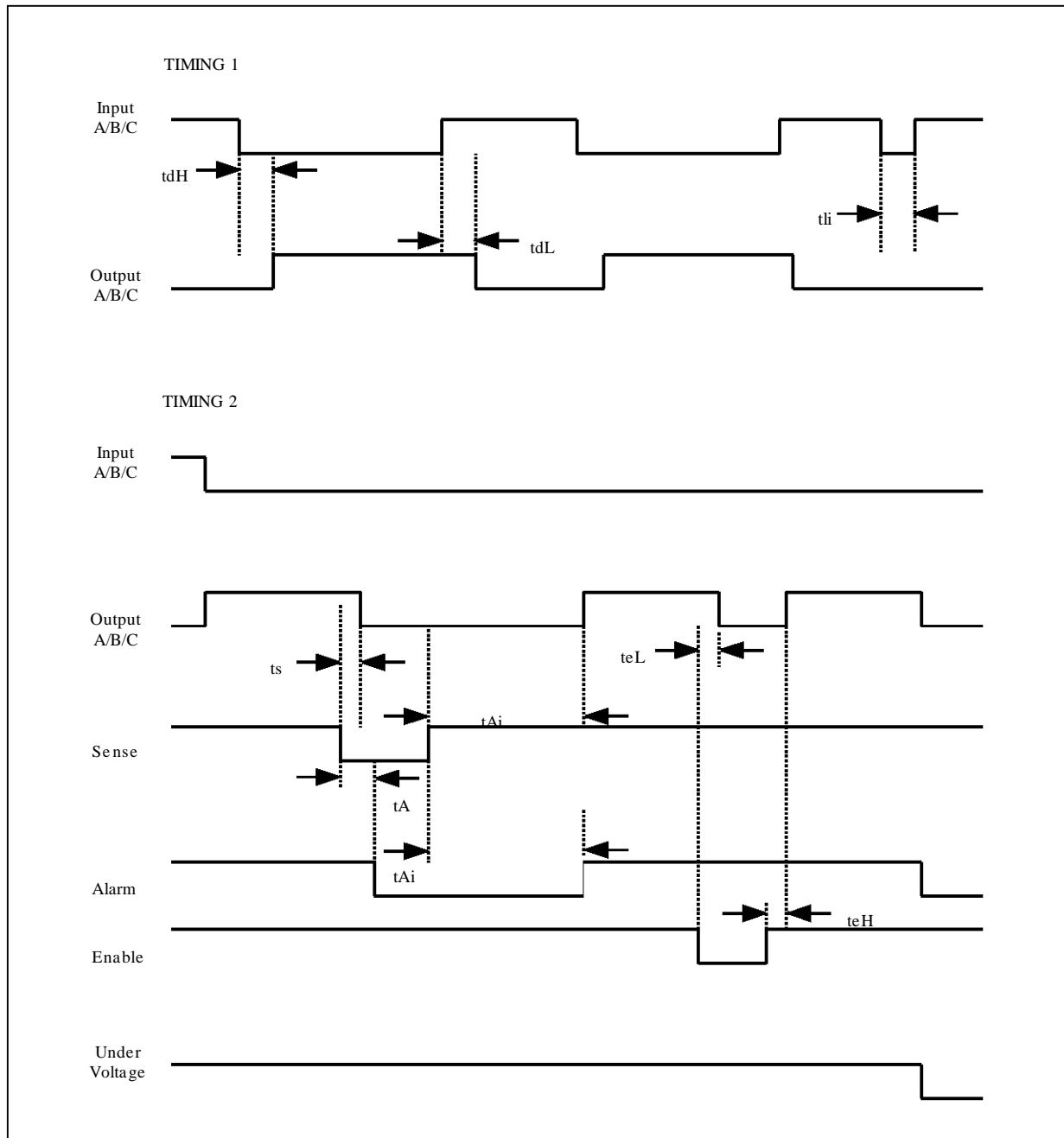

TYPICAL APPLICATIONS

Figure 1 : THREE PHASE MOTOR DRIVE

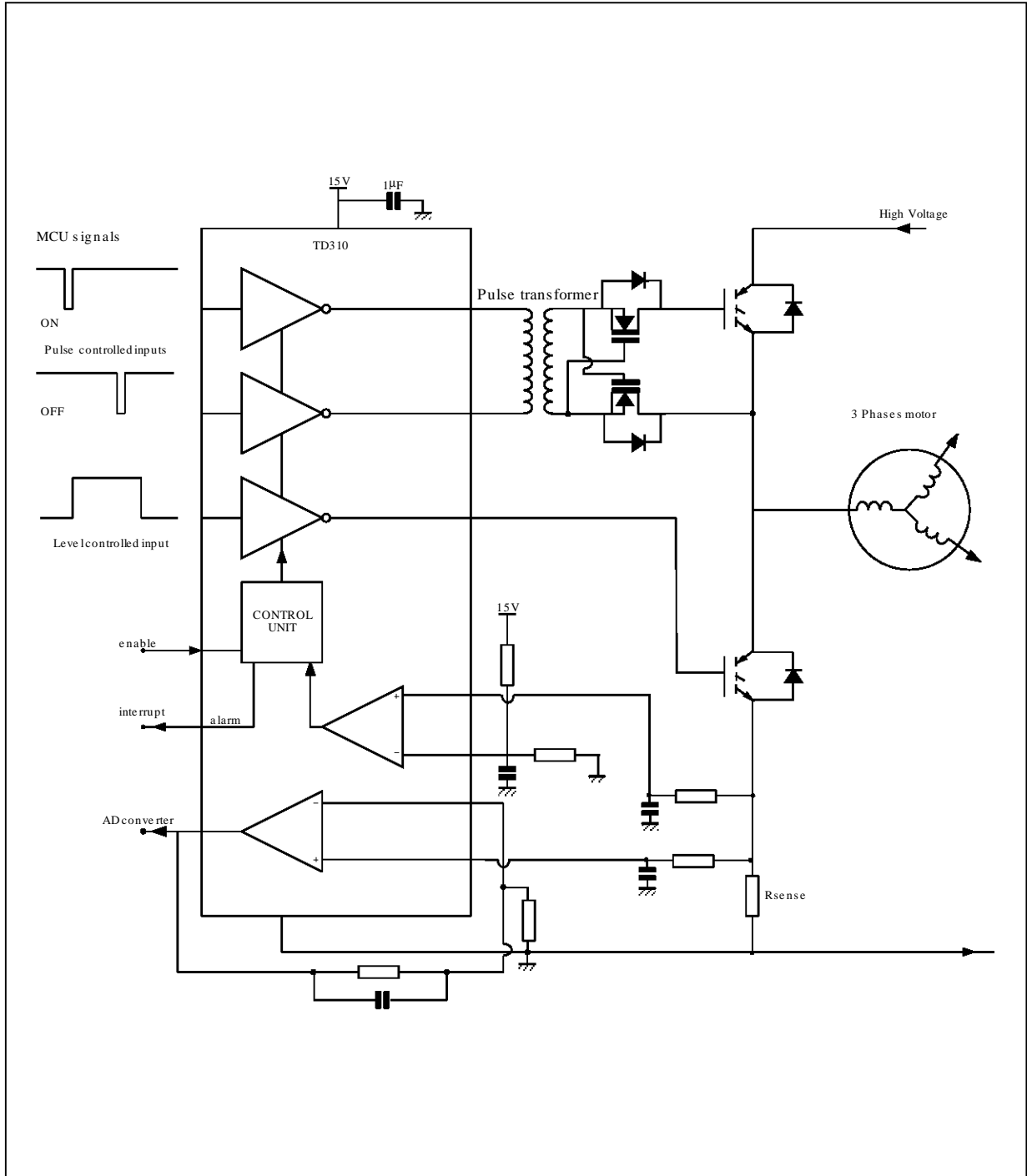

Figure 2 : THREE PHASE MOTOR LOW SIDE DRIVE

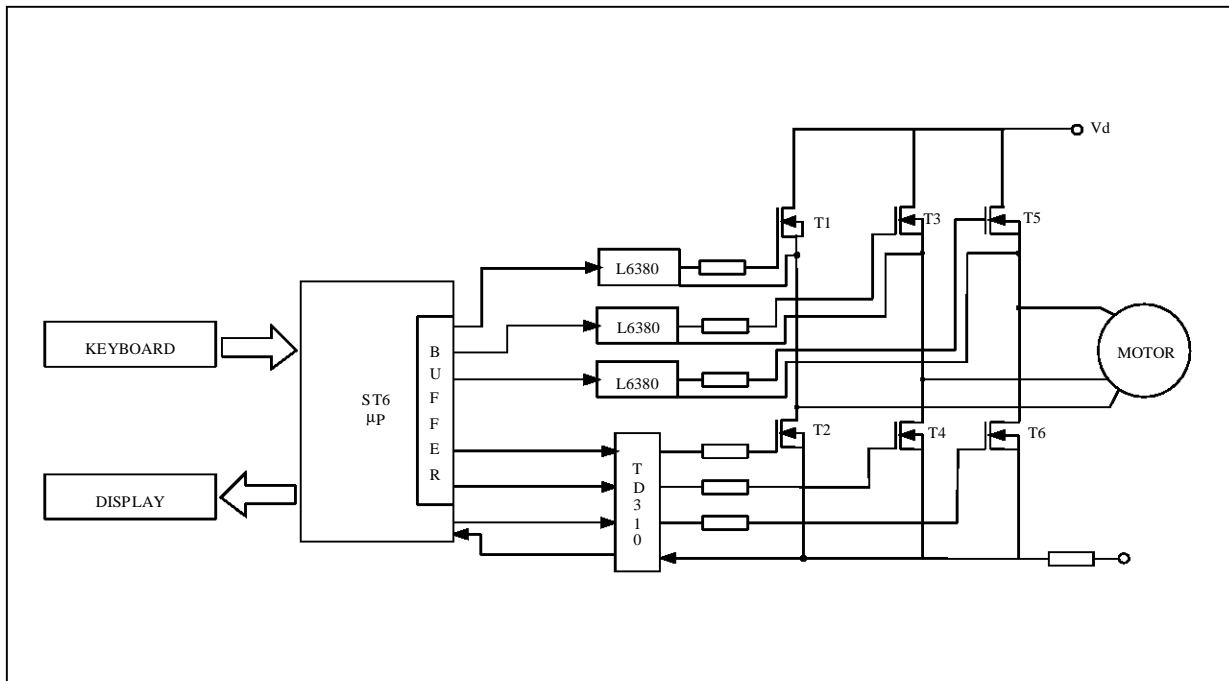
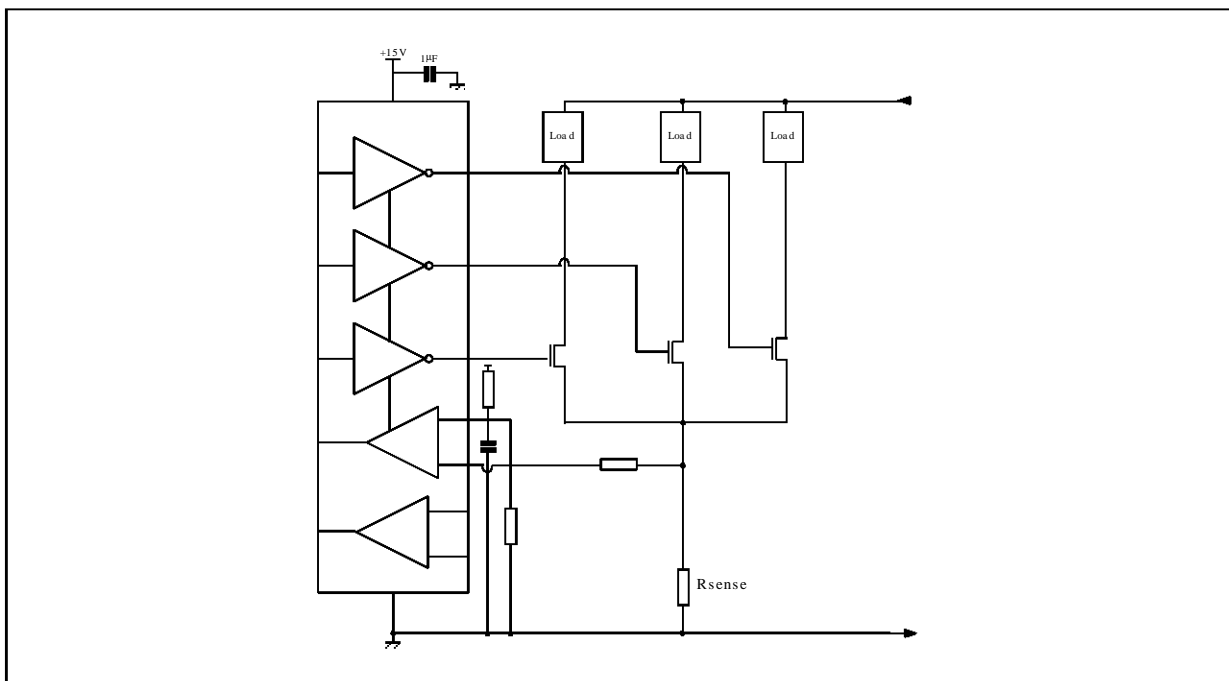

Figure 3 : LOW SIDE DRIVE



TD310

PACKAGE MECHANICAL DATA

16 PINS - PLASTIC DIP

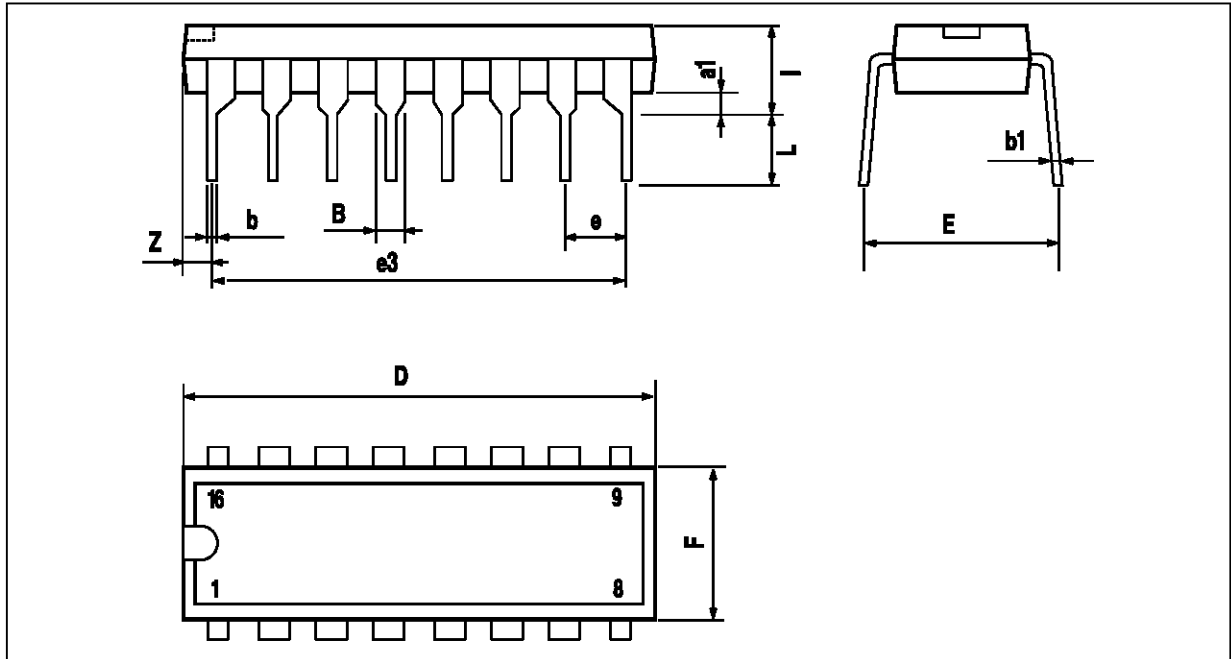

PM-DIP16EPS

Dimensions	Millimeters			Inches		
	Min.	Typ.	Max.	Min.	Typ.	Max.
a1	0.51			0.020		
B	0.77		1.65	0.030		0.065
b		0.5			0.020	
b1		0.25			0.010	
D			20			0.787
E		8.5			0.335	
e		2.54			0.100	
e3		17.78			0.700	
F			7.1			0.280
i			5.1			0.201
L		3.3			0.130	
Z			1.27			0.050

DIP16.TBL

PACKAGE MECHANICAL DATA

16 PINS - PLASTIC MICROPACKAGE (SO)

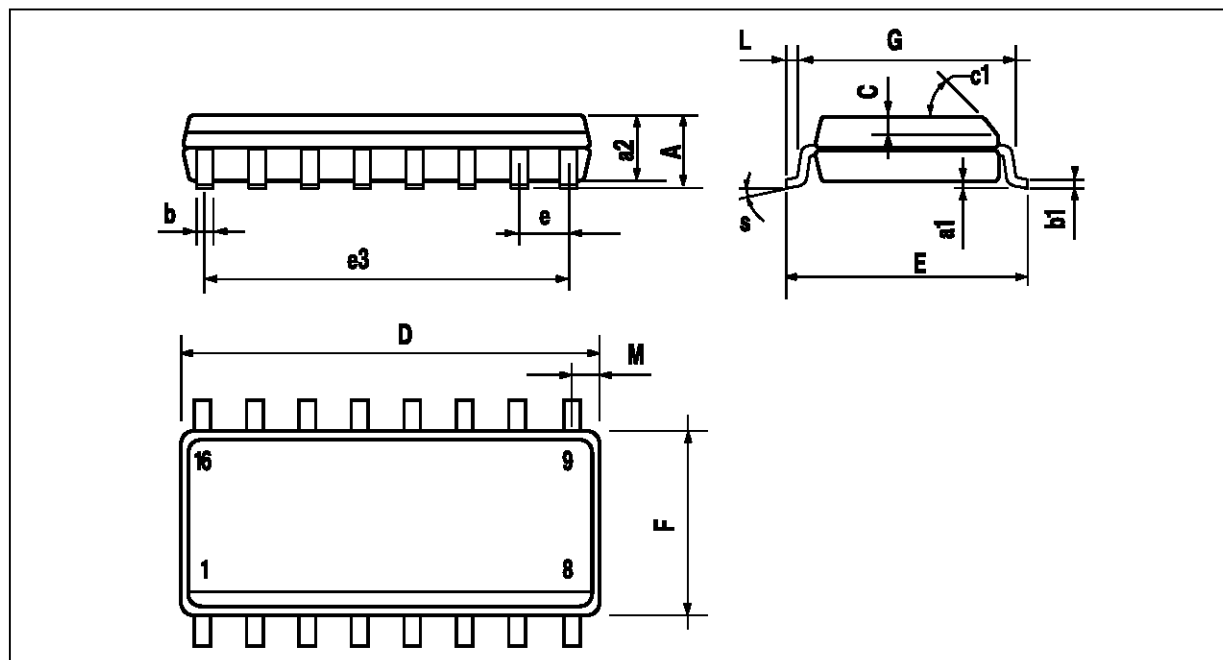

PM-SO16EPS

Dimensions	Millimeters			Inches		
	Min.	Typ.	Max.	Min.	Typ.	Max.
A			1.75			0.069
a1	0.1		0.2	0.004		0.008
a2			1.6			0.063
b	0.35		0.46	0.014		0.018
b1	0.19		0.25	0.007		0.010
C		0.5			0.020	
c1	45° (typ.)					
D	9.8		10	0.386		0.394
E	5.8		6.2	0.228		0.244
e		1.27			0.050	
e3		8.89			0.350	
F	3.8		4.0	0.150		0.157
G	4.6		5.3	0.181		0.209
L	0.5		1.27	0.020		0.050
M			0.62			0.024

SO16-TBL

Information furnished is believed to be accurate and reliable. However, SGS-THOMSON Microelectronics assumes no responsibility for the consequences of use of such information nor for any infringement of patents or other rights of third parties which may result from its use. No license is granted by implication or otherwise under any patent or patent rights of SGS-THOMSON Microelectronics. Specifications mentioned in this publication are subject to change without notice. This publication supersedes and replaces all information previously supplied. SGS-THOMSON Microelectronics products are not authorized for use as critical components in life support devices or systems without express written approval of SGS-THOMSON Microelectronics.

© 1997 SGS-THOMSON Microelectronics – Printed in Italy – All Rights Reserved

SGS-THOMSON Microelectronics GROUP OF COMPANIES

Australia - Brazil - Canada - China - France - Germany - Hong Kong - Italy - Japan - Korea - Malaysia - Malta - Morocco
The Netherlands - Singapore - Spain - Sweden - Switzerland - Taiwan - Thailand - United Kingdom - U.S.A.

ORDER CODE :