

**INTEGRATED CIRCUITS**

# DATA SHEET

**TDA1001B**

**TDA1001BT**

Interference and noise suppression  
circuit for FM receivers

Product specification  
File under Integrated Circuits, IC01

December 1982

## Interference and noise suppression circuit for FM receivers

**TDA1001B**  
**TDA1001BT**

### GENERAL DESCRIPTION

The TDA1001B is a monolithic integrated circuit for suppressing interference and noise in FM mono and stereo receivers.

### Features

- Active low-pass and high-pass filters
- Interference pulse detector with adjustable and controllable response sensitivity
- Noise detector designed for FM i.f. amplifiers with ratio detectors or quadrature detectors
- Schmitt trigger for generating an interference suppression pulse
- Active pilot tone generation (19 kHz)
- Internal voltage stabilization

### QUICK REFERENCE DATA

Supply voltage (pin 9)	$V_P$	typ.	12	V
Supply current (pin 9)	$I_P$	typ.	14	mA
A.F. input signal handling (pin 1) (peak-to-peak value)	$V_{i(p-p)}$	typ.	1	V
Input resistance (pin 1)	$R_i$	min.	35	k $\Omega$
Voltage gain ( $V_{1-16}/V_{6-16}$ )	$G_v$	typ.	0,5	dB
Total harmonic distortion	THD	typ.	0,25	%
Bandwidth	B	typ.	70	kHz
Suppression pulse threshold voltage (peak value); $R_{13} = 0$	$V_{i(tr)OM}$	typ.	19	mV
Suppression pulse duration	$t_s$	typ.	27	$\mu$ s
Supply voltage range (pin 9)	$V_P$		7,5 to 16	V
Operating ambient temperature range	$T_{amb}$		-30 to + 80	$^{\circ}$ C

### PACKAGE OUTLINE

TDA1001B: 16-lead DIL; plastic (SOT38); SOT38-1; 1996 September 06.

TDA1001BT: 16-lead mini-pack; plastic (SO16; SOT109A); SOT116-1; 1996 September 06.

# Interference and noise suppression circuit for FM receivers

TDA1001B  
TDA1001BT

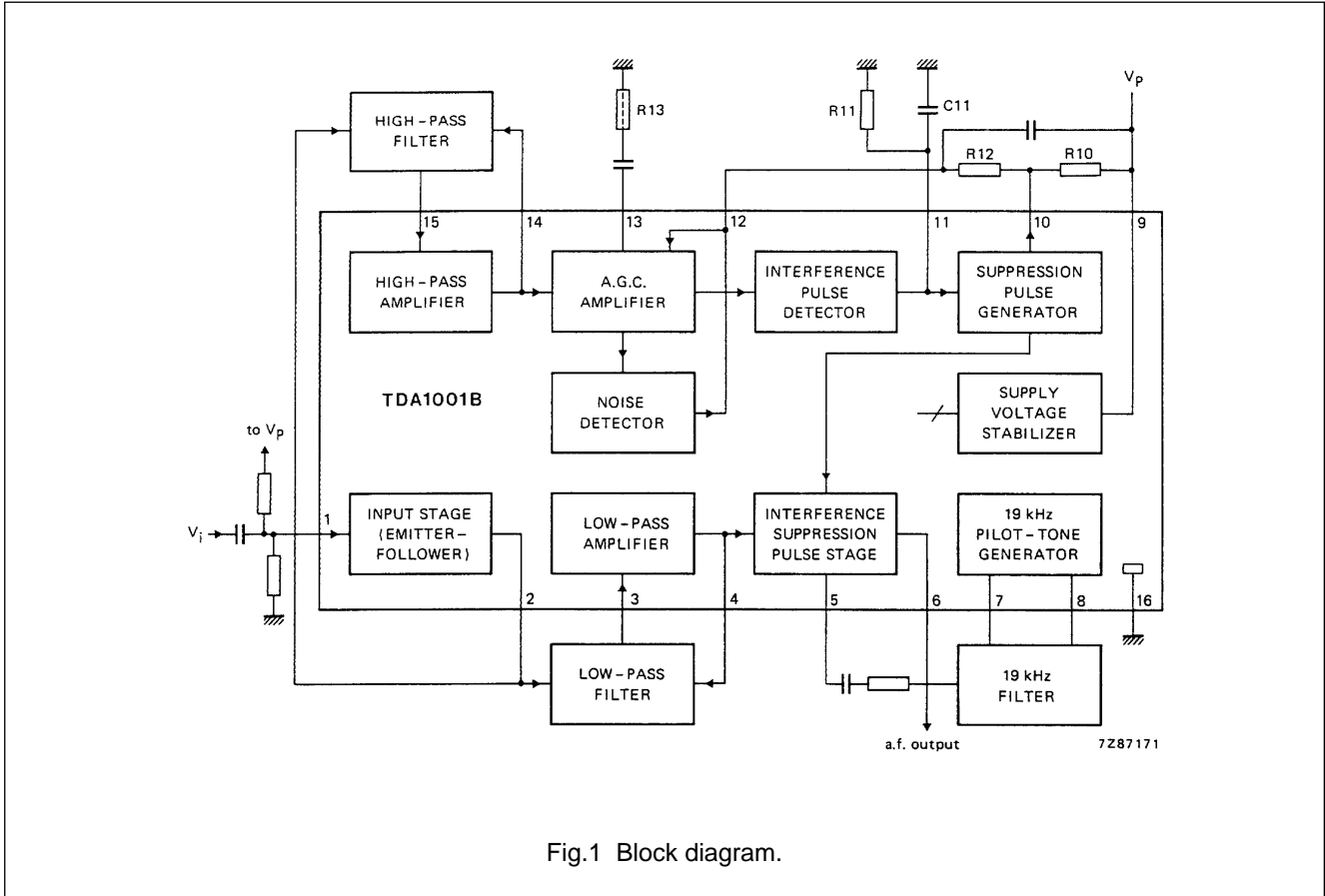

Fig.1 Block diagram.

Interference and noise suppression circuit  
for FM receivers

TDA1001B  
TDA1001BT

**RATINGS**

Limiting values in accordance with the Absolute Maximum System (IEC 134)

Supply voltage (pin 9)	$V_P$	max. 18	V
Input voltage (pin 1)	$V_{1-16}$	max. $V_P$	V
Output current (pin 6)	$I_6$	max. 1	mA
	$-I_6$	max. 15	mA
Total power dissipation		see derating curves Fig.2	
Storage temperature range	$T_{stg}$	-65 to +150	°C
Operating ambient temperature range	$T_{amb}$	-30 to +80	°C

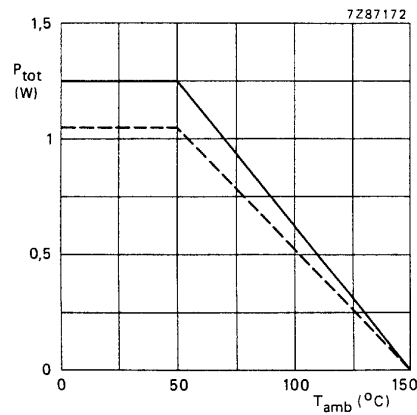

———— in plastic DIL (SOT-38) package (TDA1001B).

----- in plastic mini-pack (SO-16; SOT-109A) package (TDA1001BT); mounted on a ceramic substrate of 50 × 15 × 0,7 mm.

Fig.2 Power derating curves.

## Interference and noise suppression circuit for FM receivers

TDA1001B  
TDA1001BT

### CHARACTERISTICS

$V_P = 12\text{ V}$ ;  $T_{\text{amb}} = 25\text{ }^\circ\text{C}$ ; measured in Fig.4; unless otherwise specified

PARAMETER	SYMBOL	MIN.	TYP.	MAX.	UNIT
<b>Input stage</b>					
Input impedance (pin 1) f = 40 kHz	$ Z_{i1} $	–	45	–	k $\Omega$
Input resistance (pin 1) with pin 2 not connected	$R_{i1}$	–	600	–	k $\Omega$
Input bias current (pin 1) $V_{1-16} = 4,8\text{ V}$	$I_{i1}$	–	6	15	$\mu\text{A}$
Output resistance (pin 2) unloaded	$R_{o2}$		low-ohmic		
Internal emitter resistance	$R_{2-16}$	–	5,6	–	k $\Omega$
<b>Low-pass amplifier</b>					
Input resistance (pin 3)	$R_{i3}$	10	–	–	M $\Omega$
Input bias current (pin 3)	$I_{i3}$	–	–	7	$\mu\text{A}$
Output resistance (pin 4)	$R_{o4}$	–	–	5	$\Omega$
Voltage gain ( $V_4/V_3$ )	$G_{v4/3}$	–	1,1	–	
<b>Suppression pulse stage</b>					
Input offset current at pin 5 during the suppression time $t_S$	$I_{io5}$	–	50	200	nA
<b>Output stage</b>					
Output resistance (pin 6)	$R_{o6}$		low-ohmic		
Internal emitter resistance	$R_{6-16}$	–	6	–	k $\Omega$
Current gain ( $I_5/I_6$ )	$G_{i5/6}$	–	85	–	dB
<b>Pilot tone generation (19 kHz)</b>					
Input impedance (pin 8)	$ Z_{i8} $	–	–	1	$\Omega$
Output impedance (pin 7) pin 8 open	$ Z_{o7} $	150	–	–	k $\Omega$
Output bias current (pin 7)	$I_{o7}$	0,7	1	1,3	mA
Current gain ( $I_7/I_8$ )	$G_{i7/8}$	–	3	–	
<b>High-pass amplifier</b>					
Input resistance (pin 15)	$R_{i15}$	10	–	–	M $\Omega$
Input bias current (pin 15)	$I_{i15}$	–	–	7	$\mu\text{A}$
Output resistance (pin 14)	$R_{o14}$	–	–	5	$\Omega$
Voltage gain ( $V_{14/15}$ )	$G_{v14/15}$	–	1,4	–	

## Interference and noise suppression circuit for FM receivers

TDA1001B  
TDA1001BT

PARAMETER	SYMBOL	MIN.	TYP.	MAX.	UNIT
<b>A.G.C. amplifier; interference and noise detectors</b>					
Internal resistance (pins 13 and 14)	$R_{13-14}$	1,5	2,0	2,5	$k\Omega$
Operational threshold voltage (uncontrolled); peak value (pin 14) of the interference pulse detector	$\pm V_{14int\ m}$	–	15	–	mV
of the noise detector	$\pm V_{14n\ m}$	–	6,5	–	mV
Output voltage (peak value; pin 11)	$V_{11-16M}$	5,2	5,8	6,4	V
Output control current (pin 12) (peak value)	$I_{12M}$	150	200	250	$\mu A$
Output bias current (pin 12)	$I_{o12}$	–	2,5	6	$\mu A$
Input threshold voltage for onset of control (pin 12) ( $V_{i(tr)O} + 3\ dB$ )	$V_{12-9}$ or:	360	425 0,66 $V_{BE}$	500	mV mV
<b>Suppression pulse generation (Schmitt trigger)</b>					
Switching threshold (pin 11) 1: gate disabled	$V_{11-16}$	–	3,2	–	V
2: gate enabled	$V_{11-16}$	–	2,0	–	V
Switching hysteresis	$\Delta V_{11-16}$	–	1,2	–	V
Input offset current (pin 11)	$I_{io11}$	–	–	100	nA
Output current (pin 10) gate disabled; peak value	$I_{o10M}$	0,6	1	1,4	mA
Reverse output current (pin 10)	$I_{R10}$	–	–	2	$\mu A$
Sensitivity (pin 10)	$V_{10-16}$	2,5	–	–	V

## Interference and noise suppression circuit for FM receivers

TDA1001B  
TDA1001BT

### APPLICATION INFORMATION

$V_P = 12\text{ V}$ ;  $T_{\text{amb}} = 25\text{ }^\circ\text{C}$ ;  $f = 1\text{ kHz}$ ; measured in Fig.4; unless otherwise specified

PARAMETER	SYMBOL	MIN.	TYP.	MAX.	UNIT
Supply voltage range (pin 9)	$V_P$	7,5	12	16	V
Quiescent supply current (pin 9)	$I_P$	10	14	18	mA
<b>Signal path</b>					
D.C. input voltage (pin 1)	$V_{1-16}$	–	4,5	–	V
Input impedance (pin 1); $f = 40\text{ kHz}$	$ Z_{i1} $	35	–	–	k $\Omega$
D.C. output voltage (pin 6)	$V_{6-16}$	2,4	2,8	–	V
Output resistance (pin 6)	$R_{o6}$		low-ohmic		
Voltage gain ( $V_6/V_1$ )	$G_{V6/1}$	0	0,5	1	dB
–3 dB point of low-pass filter	$f_{(-3\text{dB})}$	–	70	–	kHz
Sensitivity for THD < 0,5% (peak-to-peak value)	$V_{i(p-p)}$	1,2	1,8	–	V
Residual interference pulse after suppression (see Fig.3); pin 7 to ground; $V_{i(tr)M} = 100\text{mV}$ ; (peak-to-peak value)	$V_{6-16(p-p)}$	–	–	3	mV
Interference suppression at $R_{13} = 0$ ; notes 5 and 6; $V_{i(rms)} = 30\text{ mV}$ ; $f = 19\text{ kHz}$ (sinewave); $V_{i(tr)M} = 60\text{ mV}$ ; $f_r = 400\text{ Hz}$	$\alpha_{\text{int}}$	20	30	–	dB
<b>Interference processing</b>					
Input signal at pin 1; output signal at pin 10 Suppression pulse threshold voltage; control function OFF (pin 9 connected to pin 12); r.m.s. value; note 1 measured with sinewave input signal $f = 120\text{ kHz}$ ; $-V_{10-9} > 1\text{ V}$ at $R_{13} = 0\ \Omega$	$V_{i(tr)rms}$	8	11	14	mV
at $R_{13} = 2,7\text{ k}\Omega$	$V_{i(tr)rms}$	18	28,5	40	mV
voltage difference for safe triggering/ non-triggering (r.m.s. value) measured with interference pulses $f = 400\text{ Hz}$ (see Fig.3); peak value at $R_{13} = 0\ \Omega$	$\Delta V_{i(rms)}$	–	1	–	mV
at $R_{13} = 2,7\text{ k}\Omega$	$V_{i(tr)M}$	–	19	–	mV
	$V_{i(tr)M}$	–	45	–	mV
Suppression pulse duration (note 2)	$t_s$	24	27	30	$\mu\text{s}$

## Interference and noise suppression circuit for FM receivers

TDA1001B  
TDA1001BT

PARAMETER	SYMBOL	MIN.	TYP.	MAX.	UNIT
<b>Noise threshold feedback control</b> (notes 1 and 3)					
Noise input voltage (r.m.s. value) $f = 120$ kHz sinewave for $V_{12-9} = 300$ mV					
at $R_{13} = 0 \Omega$	$V_{ni(rms)}$	2,3	3,3	4,3	mV
at $R_{13} = 2,7$ k $\Omega$	$V_{ni(rms)}$	–	8,2	–	mV
for $V_{12-9} = 425$ mV ( $V_{i(tr)O} + 3$ dB)					
at $R_{13} = 0 \Omega$	$V_{ni(rms)}$	–	7,3	–	mV
at $R_{13} = 2,7$ k $\Omega$	$V_{ni(rms)}$	–	16,5	–	mV
for $V_{12-9} = 560$ mV ( $V_{i(tr)O} + 20$ dB)					
at $R_{13} = 0 \Omega$	$V_{ni(rms)}$	33	45	57	mV
at $R_{13} = 2,7$ k $\Omega$	$V_{ni(rms)}$	–	107	–	mV
Amplification control voltage by interference intensity (note 4)					
$V_{i(rms)} = 50$ mV; $f = 19$ kHz; $V_{i(tr)M} = 300$ mV; r.m.s. value					
at repetition frequency $f_r = 1$ kHz	$V_{o6(rms)}$	49	–	56	mV
at repetition frequency $f_r = 16$ kHz	$V_{o6(rms)}$	45	–	65	mV

### Notes to application information

- The interference suppression and noise feedback control thresholds can be determined by  $R_{13}$  or a capacitive voltage divider at the input of the high-pass filter and they are defined by the following formulae:  
 $V_{i(tr)} = (1 + R_{13}/R_S) \times V_{i(tr)O}$  in which  $R_S = 2$  k $\Omega$ ;  
 $V_{ni} = (1 + R_{13}/R_S) \times V_{niO}$  in which  $R_S = 2$  k $\Omega$ .
- The suppression pulse duration is determined by  $C_{11} = 2,2$  nF and  $R_{11} = 6,8$  k $\Omega$ .
- The characteristic of the noise feedback control is determined by  $R_{12}$  (and  $R_{10}$ ).
- The feedback control of the interference suppression threshold at higher repetition frequencies is determined by  $R_{10}$  (and  $R_{12}$ ).
- The 19 kHz generator can be adjusted with  $R_{7-16}$  (and  $R_{7-8}$ ). Adjustment is not required if components with small tolerances are used e.g.  $\Delta R < 1\%$  and  $\Delta C < 2\%$ .
- Measuring conditions:  
The peak output noise voltage ( $V_{no m}$ , CCITT filter) shall be measured at the output with a de-emphasizing time  $T = 50$   $\mu$ s ( $R = 5$  k $\Omega$ ,  $C = 10$  nF); the reference value of 0 dB is  $V_{o int}$  with the 19 kHz generator short-circuited (pin 7 grounded).



Interference and noise suppression circuit  
for FM receivers

TDA1001B  
TDA1001BT

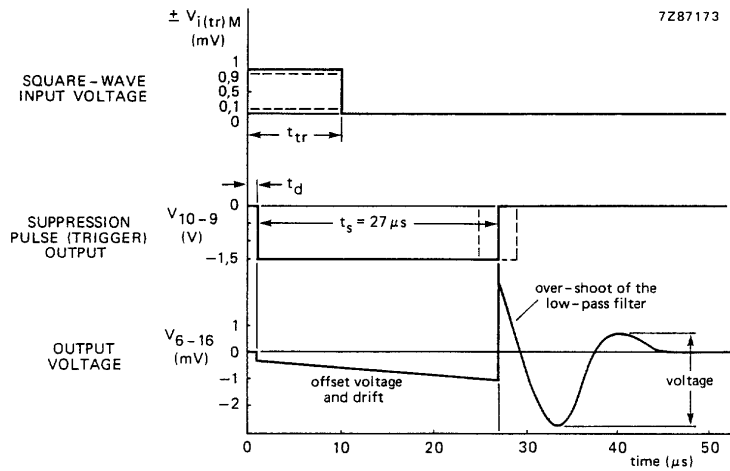

Fig.3 Measuring signal for interference suppression; at the input (pin 1) a square-wave is applied with a duration of  $t_{tr} = 10 \mu s$  and with rise and fall times  $t_r = t_f = 10 ns$ .

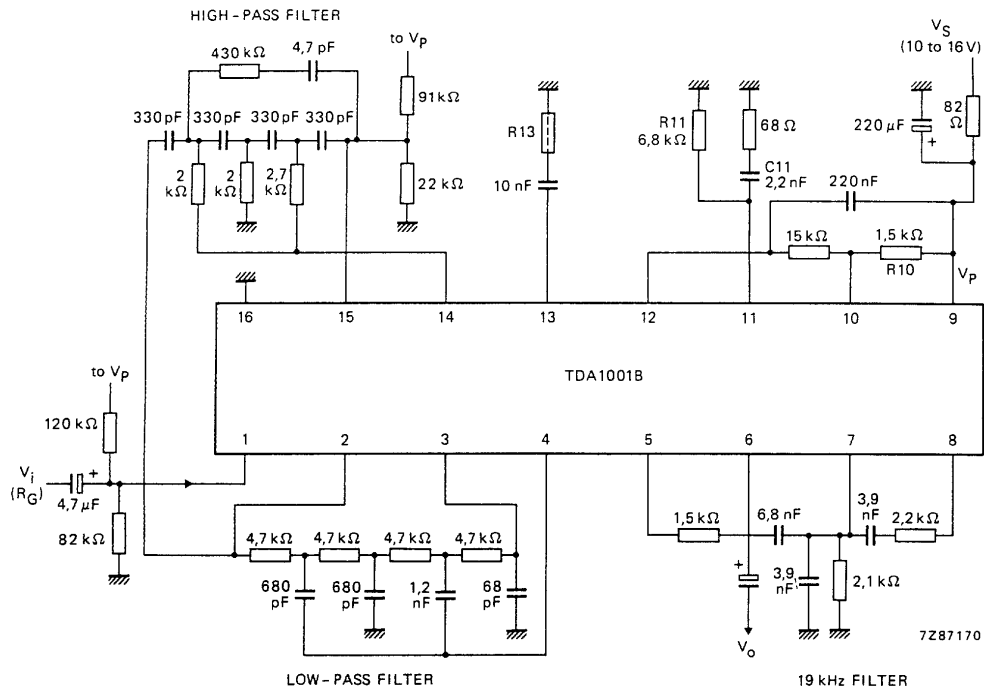

Fig.4 Application circuit diagram.

Interference and noise suppression circuit  
for FM receivers

TDA1001B  
TDA1001BT

PACKAGE OUTLINES

DIP16: plastic dual in-line package; 16 leads (300 mil); long body

SOT38-1

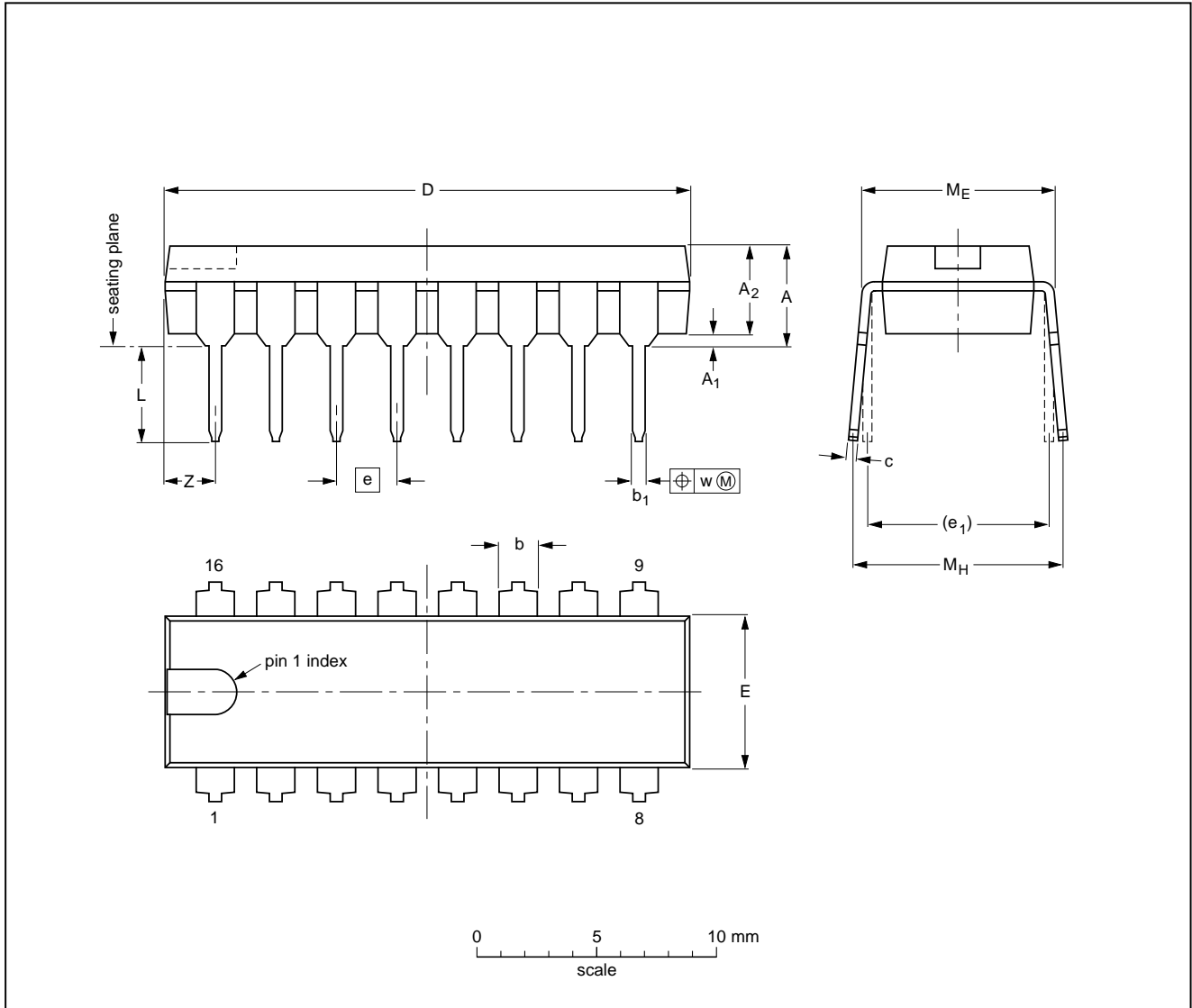

DIMENSIONS (inch dimensions are derived from the original mm dimensions)

UNIT	A max.	A <sub>1</sub> min.	A <sub>2</sub> max.	b	b <sub>1</sub>	c	D <sup>(1)</sup>	E <sup>(1)</sup>	e	e <sub>1</sub>	L	M <sub>E</sub>	M <sub>H</sub>	w	z <sup>(1)</sup> max.
mm	4.7	0.51	3.7	1.40 1.14	0.53 0.38	0.32 0.23	21.8 21.4	6.48 6.20	2.54	7.62	3.9 3.4	8.25 7.80	9.5 8.3	0.254	2.2
inches	0.19	0.020	0.15	0.055 0.045	0.021 0.015	0.013 0.009	0.86 0.84	0.26 0.24	0.10	0.30	0.15 0.13	0.32 0.31	0.37 0.33	0.01	0.087

Note

1. Plastic or metal protrusions of 0.25 mm maximum per side are not included.

OUTLINE VERSION	REFERENCES			EUROPEAN PROJECTION	ISSUE DATE
	IEC	JEDEC	EIAJ		
SOT38-1	050G09	MO-001AE			92-10-02 95-01-19

Interference and noise suppression circuit  
for FM receivers

TDA1001B  
TDA1001BT

SO16: plastic small outline package; 16 leads; body width 3.9 mm

SOT109-1

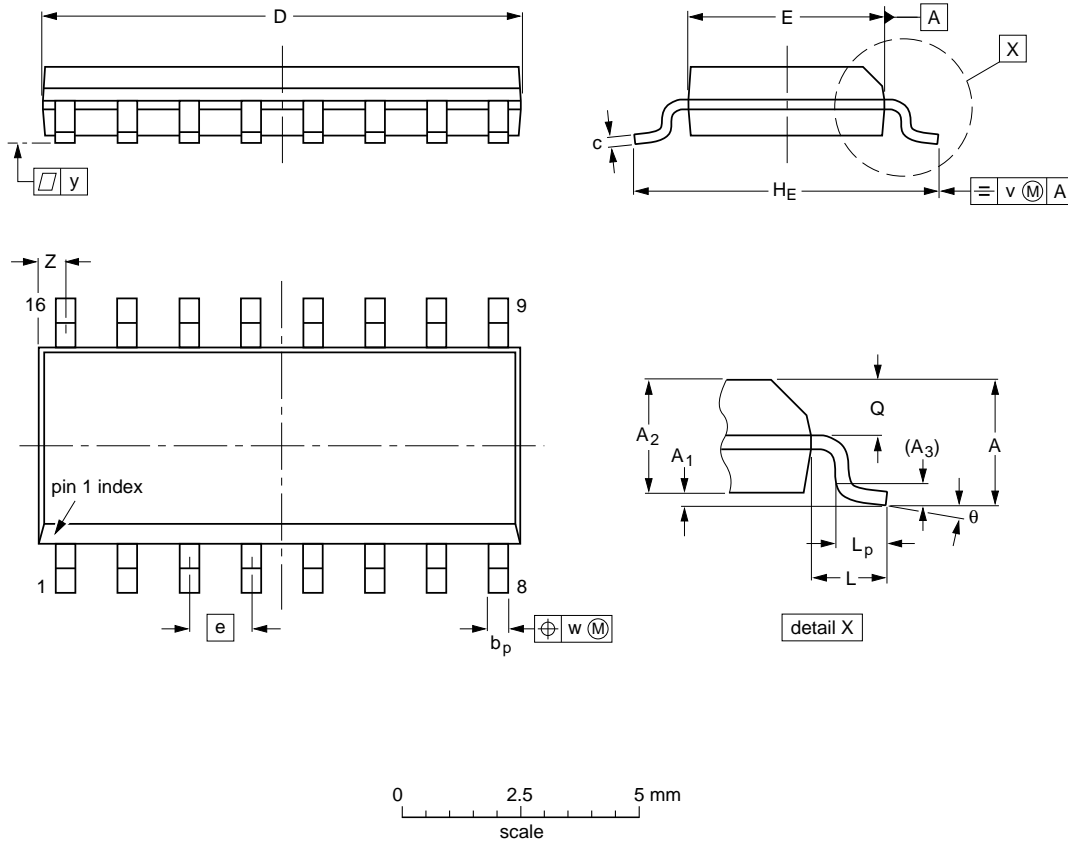

**DIMENSIONS** (inch dimensions are derived from the original mm dimensions)

UNIT	A max.	A <sub>1</sub>	A <sub>2</sub>	A <sub>3</sub>	b <sub>p</sub>	c	D <sup>(1)</sup>	E <sup>(1)</sup>	e	H <sub>E</sub>	L	L <sub>p</sub>	Q	v	w	y	Z <sup>(1)</sup>	θ
mm	1.75	0.25 0.10	1.45 1.25	0.25	0.49 0.36	0.25 0.19	10.0 9.8	4.0 3.8	1.27	6.2 5.8	1.05	1.0 0.4	0.7 0.6	0.25	0.25	0.1	0.7 0.3	8° 0°
inches	0.069	0.0098 0.0039	0.057 0.049	0.01	0.019 0.014	0.0098 0.0075	0.39 0.38	0.16 0.15	0.050	0.24 0.23	0.041	0.039 0.016	0.028 0.020	0.01	0.01	0.004	0.028 0.012	

**Note**

1. Plastic or metal protrusions of 0.15 mm maximum per side are not included.

OUTLINE VERSION	REFERENCES			EUROPEAN PROJECTION	ISSUE DATE
	IEC	JEDEC	EIAJ		
SOT109-1	076E07S	MS-012AC			91-08-13 95-01-23

## Interference and noise suppression circuit for FM receivers

TDA1001B  
TDA1001BT

### SOLDERING

#### Introduction

There is no soldering method that is ideal for all IC packages. Wave soldering is often preferred when through-hole and surface mounted components are mixed on one printed-circuit board. However, wave soldering is not always suitable for surface mounted ICs, or for printed-circuits with high population densities. In these situations reflow soldering is often used.

This text gives a very brief insight to a complex technology. A more in-depth account of soldering ICs can be found in our *"IC Package Databook"* (order code 9398 652 90011).

#### DIP

##### SOLDERING BY DIPPING OR BY WAVE

The maximum permissible temperature of the solder is 260 °C; solder at this temperature must not be in contact with the joint for more than 5 seconds. The total contact time of successive solder waves must not exceed 5 seconds.

The device may be mounted up to the seating plane, but the temperature of the plastic body must not exceed the specified maximum storage temperature ( $T_{stg\ max}$ ). If the printed-circuit board has been pre-heated, forced cooling may be necessary immediately after soldering to keep the temperature within the permissible limit.

##### REPAIRING SOLDERED JOINTS

Apply a low voltage soldering iron (less than 24 V) to the lead(s) of the package, below the seating plane or not more than 2 mm above it. If the temperature of the soldering iron bit is less than 300 °C it may remain in contact for up to 10 seconds. If the bit temperature is between 300 and 400 °C, contact may be up to 5 seconds.

#### SO

##### REFLOW SOLDERING

Reflow soldering techniques are suitable for all SO packages.

Reflow soldering requires solder paste (a suspension of fine solder particles, flux and binding agent) to be applied to the printed-circuit board by screen printing, stencilling or pressure-syringe dispensing before package placement.

Several techniques exist for reflowing; for example, thermal conduction by heated belt. Dwell times vary between 50 and 300 seconds depending on heating method. Typical reflow temperatures range from 215 to 250 °C.

Preheating is necessary to dry the paste and evaporate the binding agent. Preheating duration: 45 minutes at 45 °C.

##### WAVE SOLDERING

Wave soldering techniques can be used for all SO packages if the following conditions are observed:

- A double-wave (a turbulent wave with high upward pressure followed by a smooth laminar wave) soldering technique should be used.
- The longitudinal axis of the package footprint must be parallel to the solder flow.
- The package footprint must incorporate solder thieves at the downstream end.

During placement and before soldering, the package must be fixed with a droplet of adhesive. The adhesive can be applied by screen printing, pin transfer or syringe dispensing. The package can be soldered after the adhesive is cured.

Maximum permissible solder temperature is 260 °C, and maximum duration of package immersion in solder is 10 seconds, if cooled to less than 150 °C within 6 seconds. Typical dwell time is 4 seconds at 250 °C.

A mildly-activated flux will eliminate the need for removal of corrosive residues in most applications.

##### REPAIRING SOLDERED JOINTS

Fix the component by first soldering two diagonally-opposite end leads. Use only a low voltage soldering iron (less than 24 V) applied to the flat part of the lead. Contact time must be limited to 10 seconds at up to 300 °C. When using a dedicated tool, all other leads can be soldered in one operation within 2 to 5 seconds between 270 and 320 °C.

---

**Interference and noise suppression circuit  
for FM receivers**

---

**TDA1001B  
TDA1001BT**

---

**DEFINITIONS**

<b>Data sheet status</b>	
Objective specification	This data sheet contains target or goal specifications for product development.
Preliminary specification	This data sheet contains preliminary data; supplementary data may be published later.
Product specification	This data sheet contains final product specifications.
<b>Limiting values</b>	
Limiting values given are in accordance with the Absolute Maximum Rating System (IEC 134). Stress above one or more of the limiting values may cause permanent damage to the device. These are stress ratings only and operation of the device at these or at any other conditions above those given in the Characteristics sections of the specification is not implied. Exposure to limiting values for extended periods may affect device reliability.	
<b>Application information</b>	
Where application information is given, it is advisory and does not form part of the specification.	

**LIFE SUPPORT APPLICATIONS**

These products are not designed for use in life support appliances, devices, or systems where malfunction of these products can reasonably be expected to result in personal injury. Philips customers using or selling these products for use in such applications do so at their own risk and agree to fully indemnify Philips for any damages resulting from such improper use or sale.