

## A MAINS-ZERO TRIAC-TRIGGERING CIRCUIT

The TDA1024 is a monolithic integrated circuit intended for use in ON/OFF control of triacs in static switching applications. It incorporates zero voltage point triggering to minimize radio interference.

The TDA1024 is mainly intended for applications such as switching resistive loads and replacing mechanical thermostats in, for example:

- central heating installations,
- washing machine heaters,
- water heaters,
- smoothing irons.

### QUICK REFERENCE DATA

Supply voltage (via dropping resistor)	$V_S$	mains voltage	
Average supply current	$I_{7(av)}$	typ.	10 mA
Trigger pulse width	$t_p$	typ.	195 $\mu$ s
Max. trigger current capability	$I_{2max}$	>	100 mA

# TDA1024

## BLOCK DIAGRAM

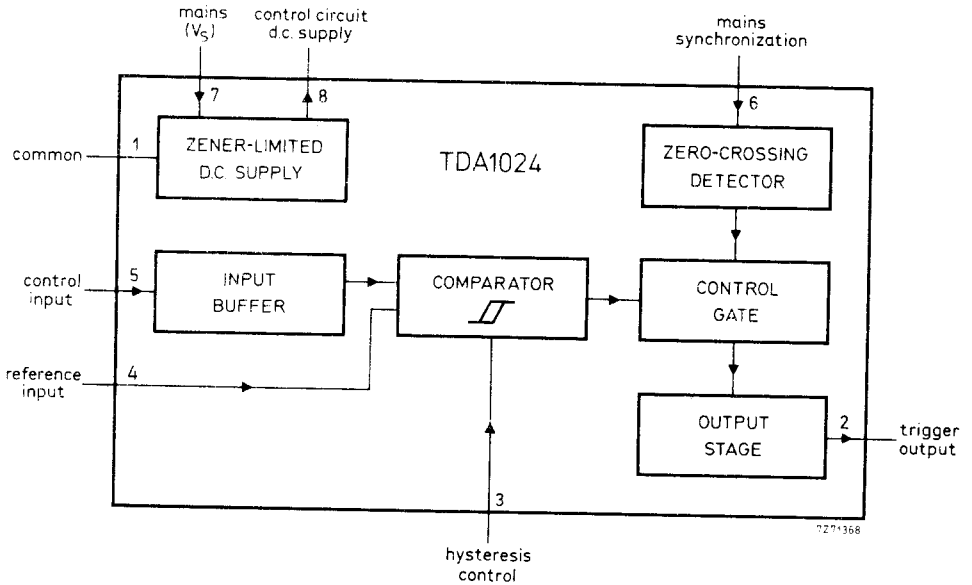

Functions of the TDA1024 are :

- a comparator with Schmitt-trigger action.  
This circuit compares the control voltage at pin 5 with the reference voltage at pin 4 and switches on when the control voltage exceeds the reference voltage. The hysteresis of the circuit is adjustable between 20 mV and 300 mV by selection of the value of a resistor connected between pin 3 and pin 1.
- an input buffer circuit with high input impedance and low output impedance. This circuit presents a low impedance to the comparator input so that the hysteresis of the circuit is independent of variations of the input voltage.
- a control circuit d.c. supply which provides a zener-limited nominal 6,5 V supply, at a current of up to 30 mA, for application to the input bridge.
- a zero-crossing detector which produces an output when the sinusoidal voltage applied to pin 6 passes through zero; advantage of this mode is minimum radio interference.
- a control gate which inhibits the output trigger pulse from the TDA1024 unless there are outputs from both zero-crossing detector and comparator.
- an output stage which delivers a positive-going, mains-synchronized triac trigger pulse whenever the control gate is activated. The output from this stage is current-limited and protected against short-circuit. Since the current and voltage in the load must be in phase for mains-synchronized switching, the applications of the TDA1024 are restricted to the switching of resistive loads.

CIRCUIT DIAGRAM

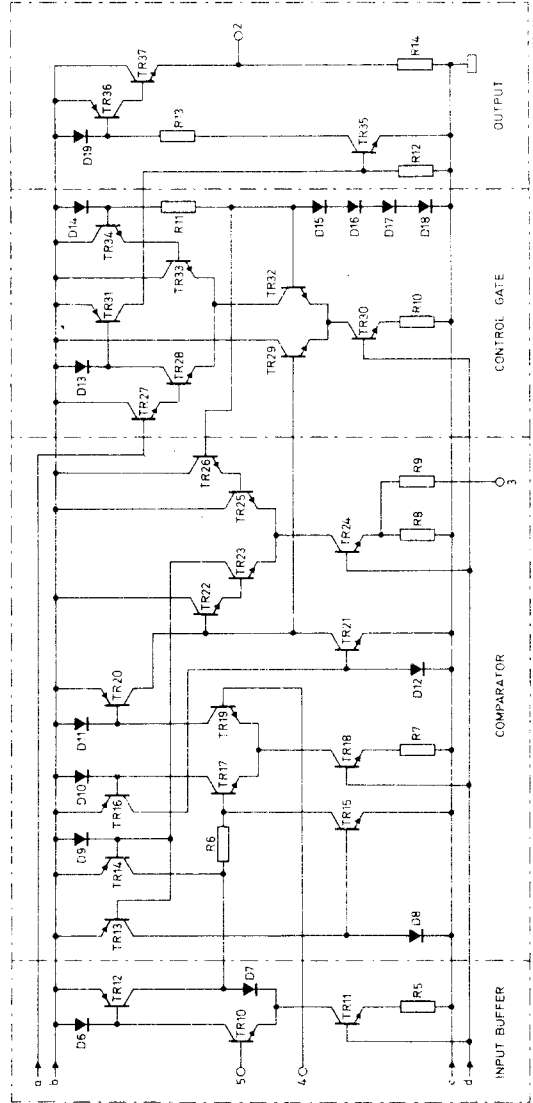
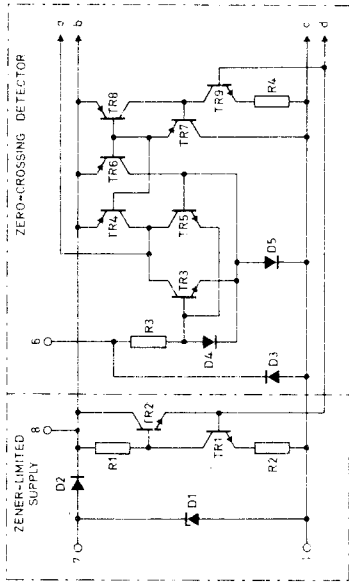

# TDA1024

**RATINGS** Limiting values in accordance with the Absolute Maximum System (IEC 134)

Voltages

Supply voltage (pin 7)	$V_S$	max.	8	V
Voltage on pins 2, 3, 4, 5 and 8	$V_{2-1}; V_{3-1}; V_{4-1};$ $V_{5-1}; V_{8-1}$	max.	8	V

Currents

Supply current (pin 7); average value	$\pm I_{7(av)}$	max.	30	mA
peak value	$\pm I_{7M}$	max.	80	mA
Current at pins 4, 5, and 6	$I_4; I_5; \pm I_6$	max.	10	mA
Non-repetitive peak current at pin 7 ( $t_p < 50 \mu s$ )	$\pm I_{7SM}$	max.	2	A
Output current (pin 2); average value	$I_{2(av)}$	max.	30	mA
peak value ( $t_p < 300 \mu s$ )	$I_{2M}$	max.	400	mA

Temperatures

Storage temperature	$T_{stg}$	-55 to +125	$^{\circ}C$
Operating ambient temperature	$T_{amb}$	-20 to +80	$^{\circ}C$

Power dissipation

Total power dissipation see derating curve below

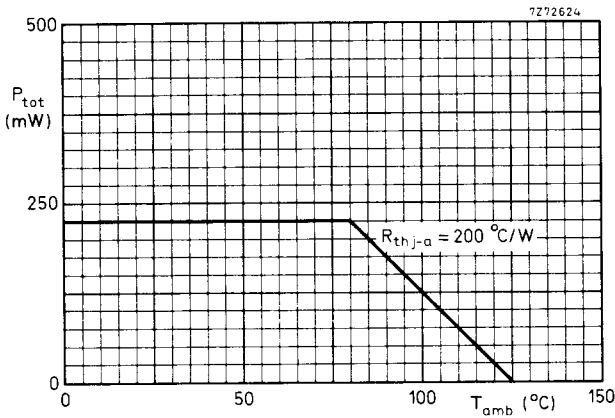

**CHARACTERISTICS** at  $T_{amb} = 25\text{ }^{\circ}\text{C}$ ;  $f = 50\text{ Hz}$ Zero-crossing detectorTrigger pulse width at  $I_{6(rms)} = 1\text{ mA}$ :

$V_{8-1} = 5,5\text{ V}$

$t_p$	typ.	195	$\mu\text{s}$
		130 to 265	$\mu\text{s}$

Synchronization resistor

see Fig. 3

Trigger output (pin 2)Max. current capability at  $V_{8-1} = 5,5\text{ V}$  $-I_{2\text{ max}} >$  100 mA

Trigger current capability

see Figures 5, 6, 7 and 8

Max. trigger voltage at  $-I_2 = 100\text{ mA}$  $V_{2-1} >$  4 V

Gate resistor

see Fig. 4

Comparator at  $V_{8-1} = 6,5\text{ V}$ Hysteresis; pin 3 not connected;  $I_3 = 0$  $\Delta V_{5-4}$  10 to 30 mVHysteresis; pin 3 connected to common;  $V_3 = 0$  $\Delta V_{5-4}$  typ. 300 mVInput current at  $V_{4-1} > V_{5-1}$  (pin 4) $I_4 <$  5  $\mu\text{A}$ 

Input current (pin 5)

 $I_5 <$  5  $\mu\text{A}$ Control circuit d.c. supply (pin 8)Voltage on pin 8 at  $I_{7(av)} = 10\text{ mA}$ 

$V_{8-1}$	typ.	6,5	V
		5,5 to 7,5	V

IC current consumption (with min. hysteresis)

pins 2 and 3 not connected;  
 $V_{5-1} > V_{4-1}$ ;  $V_{8-1} = 5,5\text{ V}$  $I_{IC} <$  1,8 mA

IC current consumption (with max. hysteresis)

pin 2 not connected; pin 3 connected to common;  
 $V_{5-1} > V_{4-1}$ ;  $V_{8-1} = 5,5\text{ V}$  $I_{IC} <$  3 mA

Total average current consumption (pin 7)

see Fig. 9

Mains dropping resistor

see Figures 10 and 11

Mains dropping capacitor

see Fig. 12

# TDA1024

## APPLICATION INFORMATION

Fig. 1

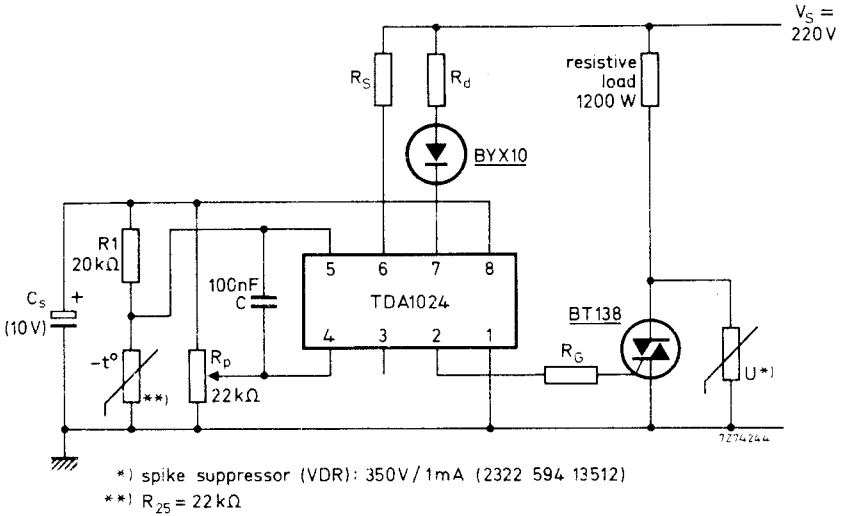

The TDA1024 used in a 1200 W thermostat covering the temperature range  $5^{\circ}\text{C}$  to  $30^{\circ}\text{C}$  and designed to minimize the power dissipated by mains dropping resistor  $R_d$  by using a rectifier diode.

Fig. 2

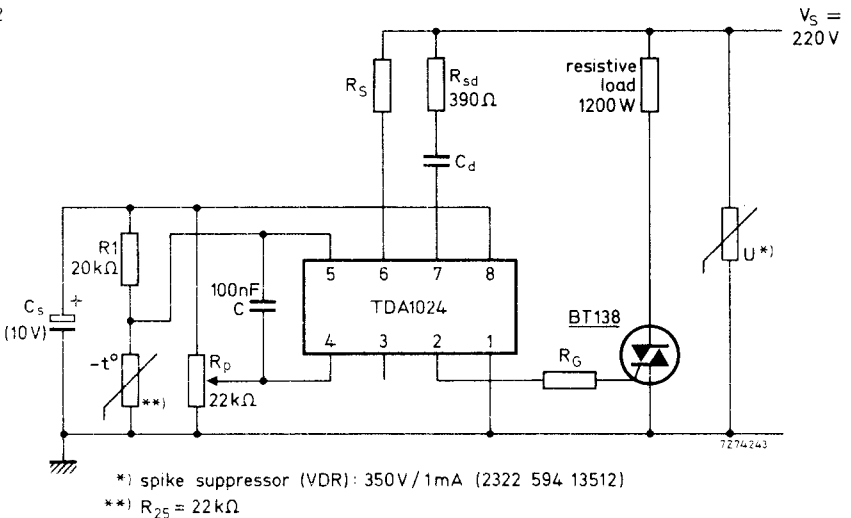

The TDA1024 used in a 1200W thermostat covering the temperature range  $5^{\circ}\text{C}$  to  $30^{\circ}\text{C}$  and designed to minimize the dissipation in the mains voltage reduction circuit by using capacitor  $C_d$ .

## APPLICATION INFORMATION (continued)

Design data for the two previous circuits (for other circuits the same sequence of component value selection must be used):

BT138 triac with:  $V_{GT} = 1,6V$  at  $0^{\circ}C$     Mains voltage:  $V_S = 220 V$   
 $I_{GT} = 72 mA$  at  $0^{\circ}C$     Triac load: 1200 W  
 $I_L < 60 mA$

Component values and circuit parameters:

parameter	Value		Figure
	Fig. 1	Fig. 2	
trigger pulse width : $t_p$ ( $\mu s$ )	105	105	*)
sync. resistor : $R_S$ ( $k\Omega$ )	180	180	3
gate resistor : $R_G$ ( $\Omega$ )	33	33	4
average gate current : $I_{2(av)}$ (mA)	3,7	3,7	6
min. required supply current : $i_7$ (mA)	6,5	6,5	9
mains dropping resistor : $R_d$ ( $k\Omega$ )	10	—	10
smoothing capacitor : $C_s$ ( $\mu F$ )	470	470	10
power dissipated by $R_d$ : $P_{Rd}$ (W)	3,2	—	11
mains dropping capacitor : $C_d$ (nF)	—	270	12
power dissipated by $R_{sd}$ : $P_{Rsd}$ (mW)	—	190	12

\*) See BT138 data sheet.

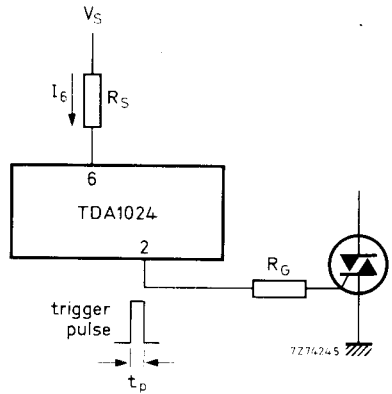
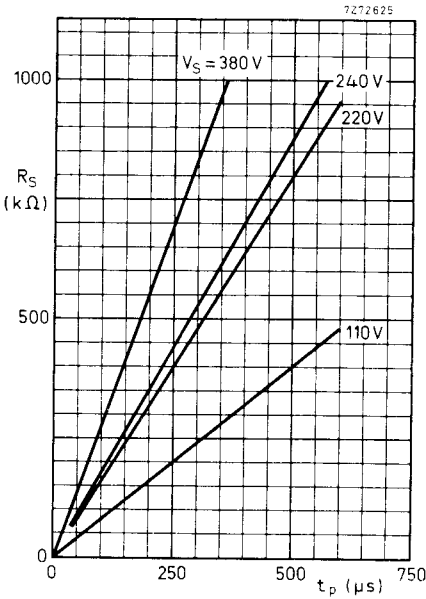

Fig. 3. Synchronization resistor ( $R_S$ ) value as a function of required trigger pulse width ( $t_p$ ) with applied mains voltage ( $V_S$ ) as a parameter. Tolerance for  $R_S$  :  $\pm 5\%$  for  $V_S$  :  $\pm 10\%$

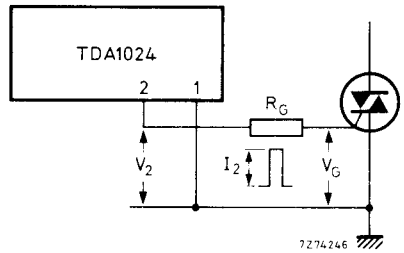
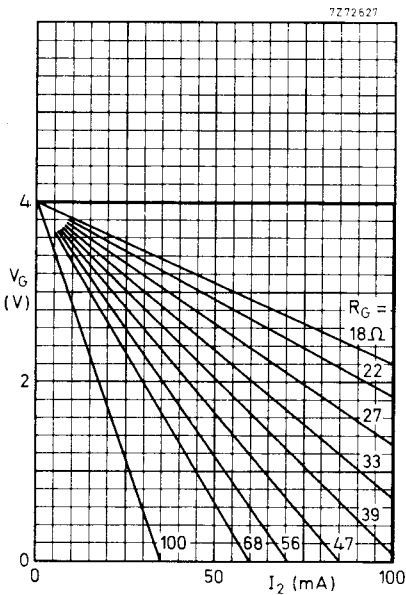
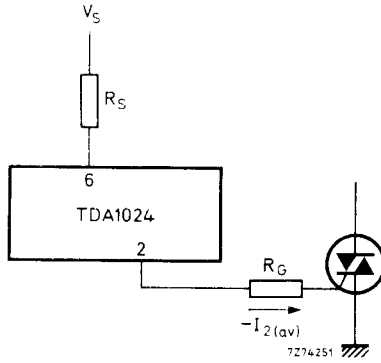

Fig. 4. Gate voltage ( $V_G$ ) as a function of trigger current ( $I_2$ ) with gate resistor ( $R_G$ ) load lines.



Figures 5, 6, 7 and 8, on the next two pages, have to be used with the circuit below. They show the maximum average trigger current  $I_{2(av)}$  as a function of the value of  $R_G$  with the value of  $R_S$  as a parameter for  $V_S = 110V; 220V; 240V; 380V$  respectively.



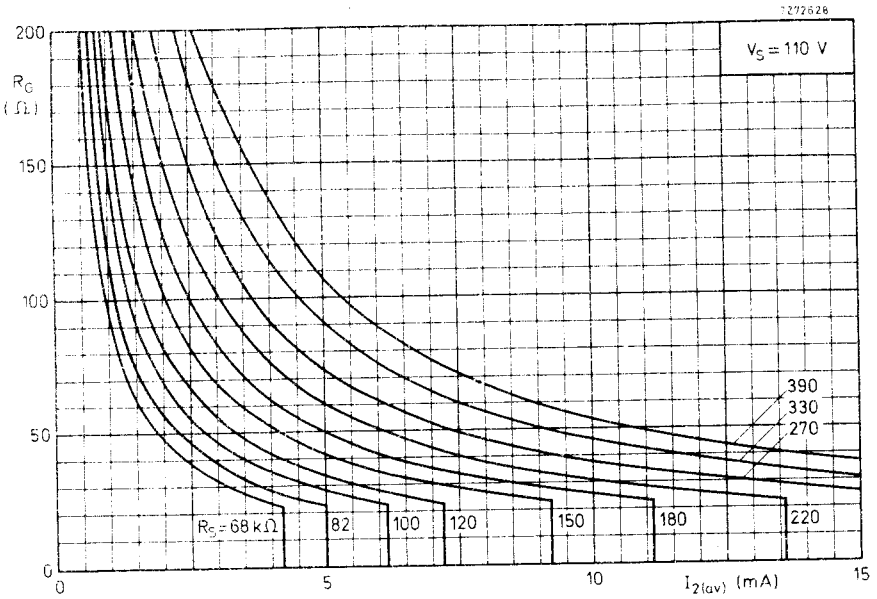

Fig. 5

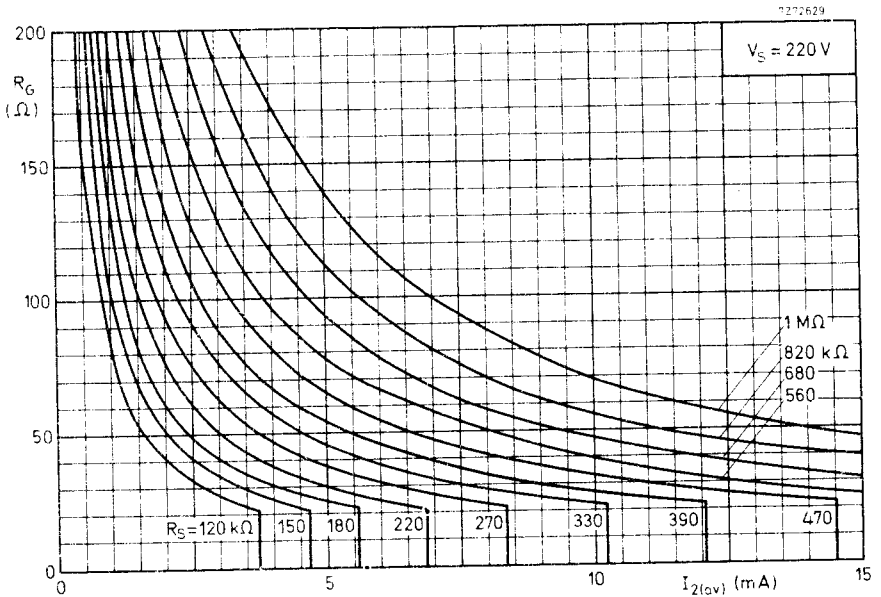

Fig. 6

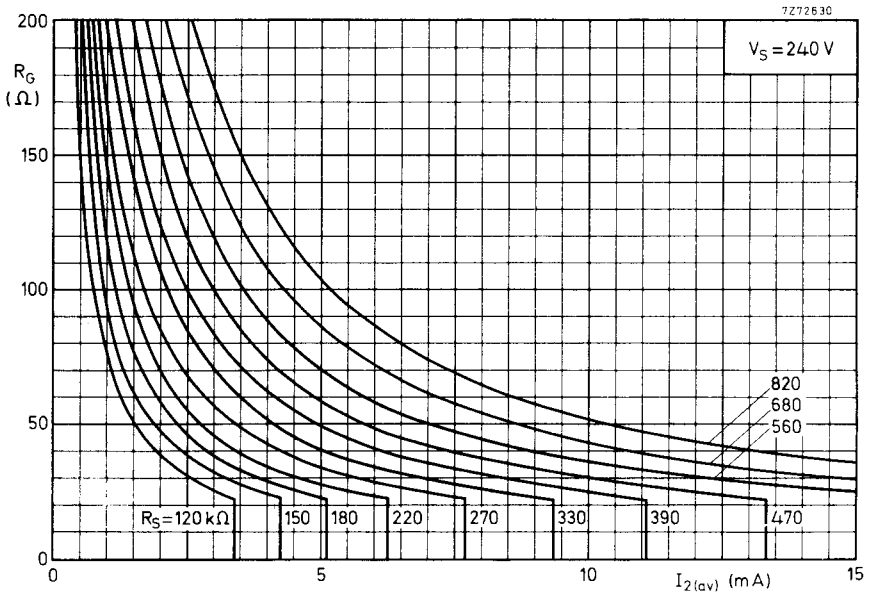

Fig. 7

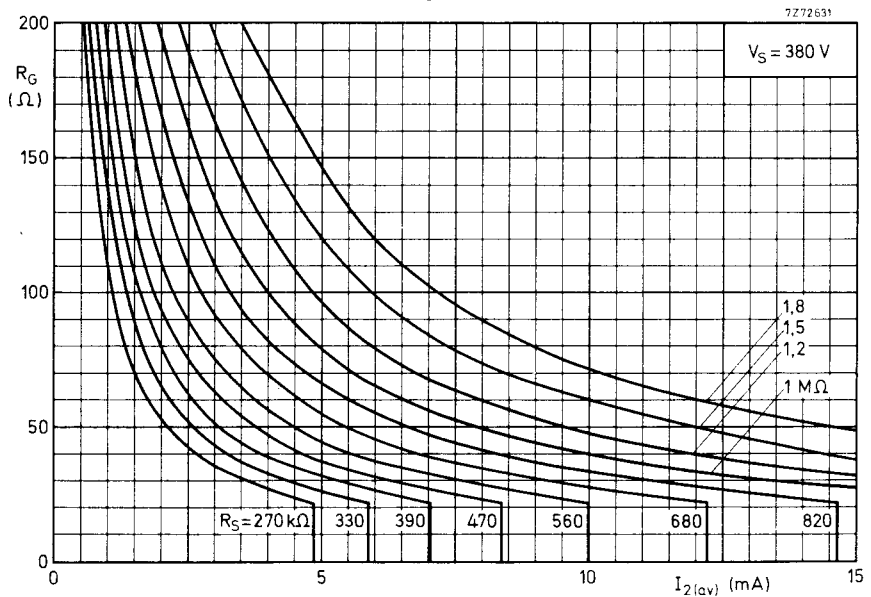

Fig. 8

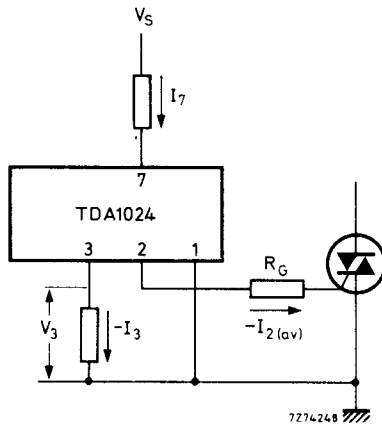
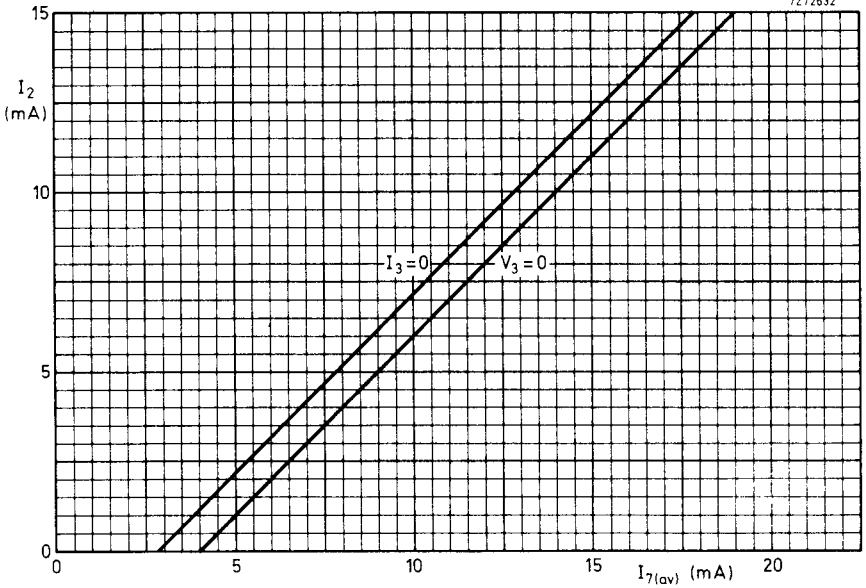

Fig. 9. Minimum required supply current ( $I_7$ ) as a function of maximum average trigger current ( $I_{2(av)}$ ), with hysteresis setting as a parameter.  
 $I_3 = 0$ ; min. hysteresis.  
 $V_3 = 0$ ; max. hysteresis.

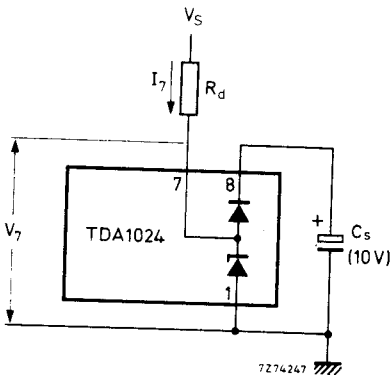
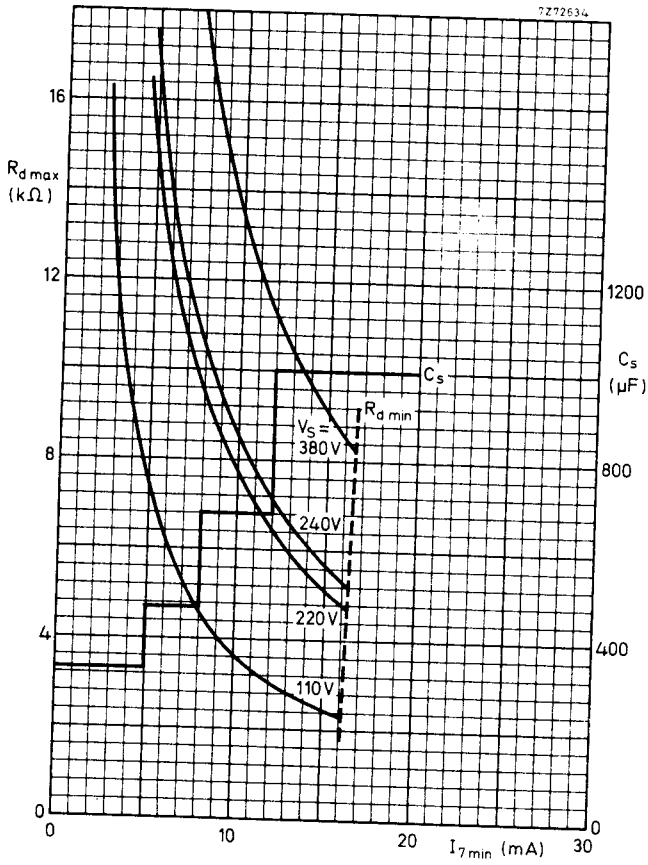

Fig. 10. Value of  $R_d \text{ max}$  as a function of  $I_{7 \text{ min}}$  with supply voltage ( $V_S$ ) as a parameter. Also shown is the value of the smoothing capacitor ( $C_s$ ) as a function of  $I_{7 \text{ min}}$ .

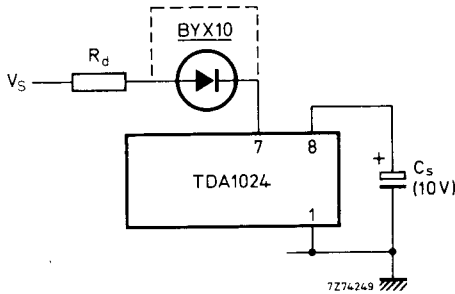
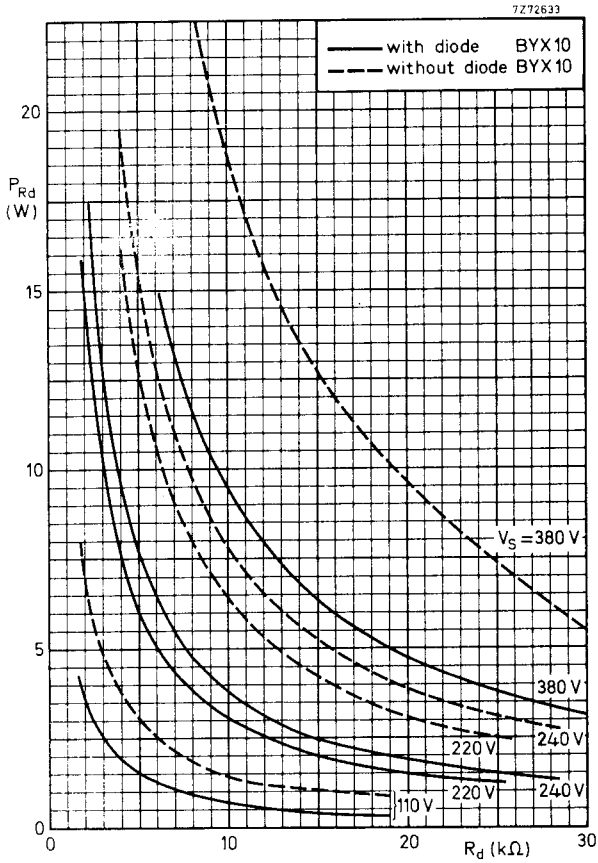
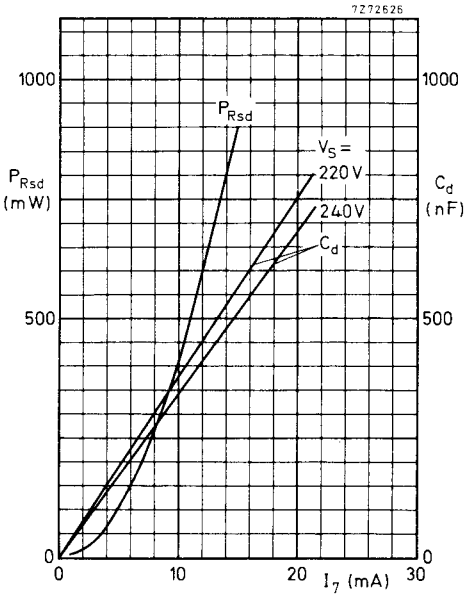

Fig. 11. The power dissipated by mains dropping resistor  $R_d$  ( $P_{R_d}$ ) as a function of its value with the supply voltage ( $V_s$ ) as a parameter.



Using a capacitor for mains supply voltage dropping.

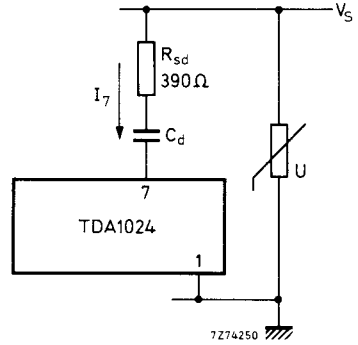

Fig. 12. Power dissipated by the dropping resistor ( $P_{Rsd}$ ) and the dropping capacitor value ( $C_d$ ) as a function of the current into pin 7 ( $I_7$ ) with the mains supply voltage ( $V_S$ ) as a parameter.