



TDA1180P

TV HORIZONTAL PROCESSOR

- NOISE GATED HORIZONTAL SYNC SEPARATOR
- NOISE GATED VERTICAL SYNC SEPARATOR
- HORIZONTAL OSCILLATOR WITH FREQUENCY RANGE LIMITER
- PHASE COMPARATOR BETWEEN SYNC PULSES AND OSCILLATOR PULSES (PLL)
- PHASE COMPARATOR BETWEEN FLYBACK PULSES AND OSCILLATOR PULSES (PLL)
- LOOP GAIN AND TIME CONSTANT SWITCHING (VCR)
- COMPOSITE BLANKING AND KEY PULSE GENERATOR
- PROTECTION CIRCUITS
- OUTPUT STAGES WITH HIGH CURRENT CAPABILITY

DESCRIPTION

The TDA1180P is a horizontal processor circuit for b.w. and colour monitors. It is a monolithic integrated circuit encapsulated in 16-lead dual in-line plastic package.

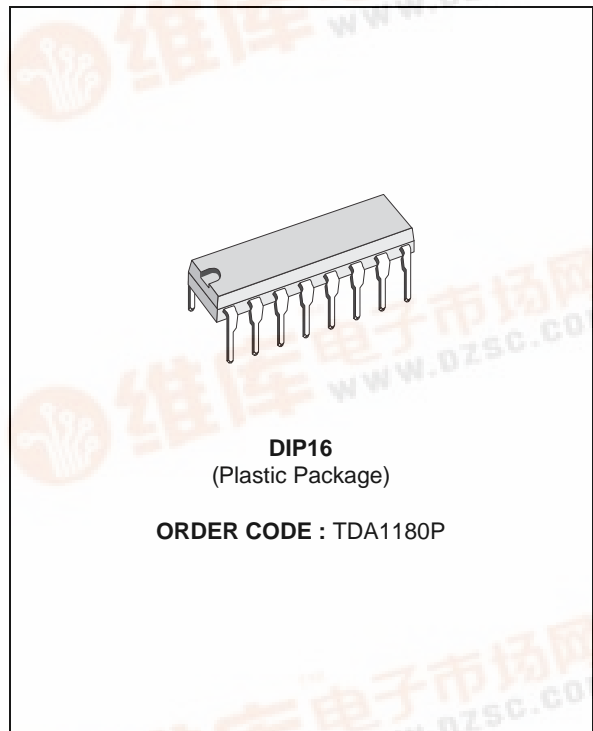

PIN CONNECTIONS

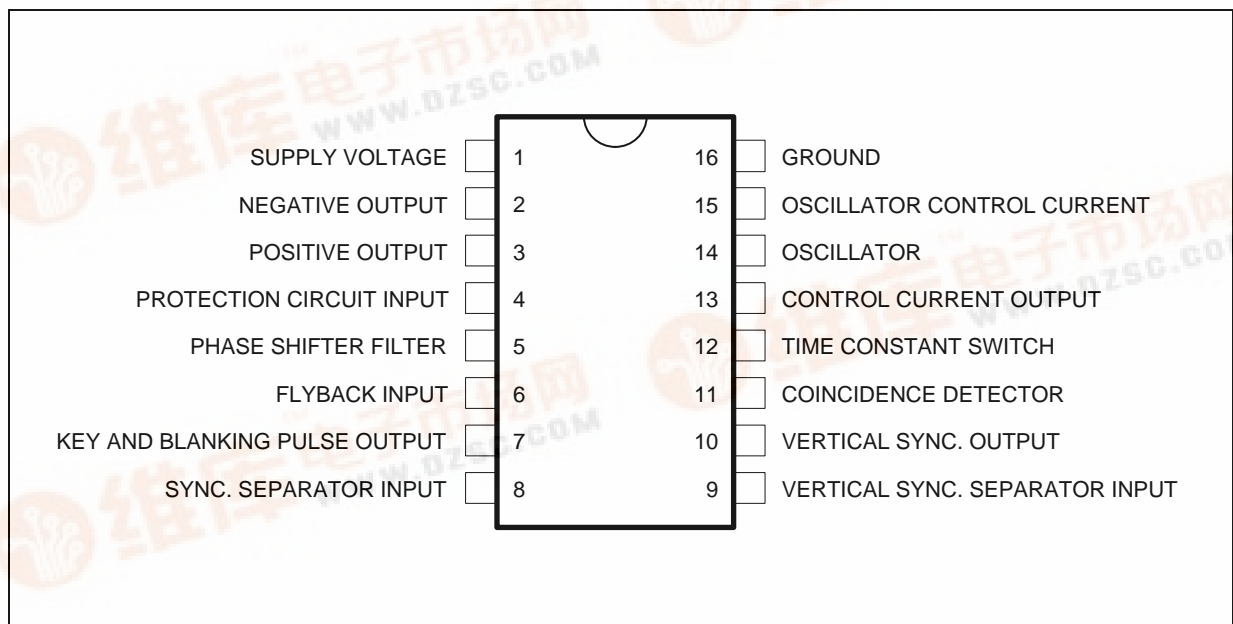

1180P-01.EPS

BLOCK DIAGRAM

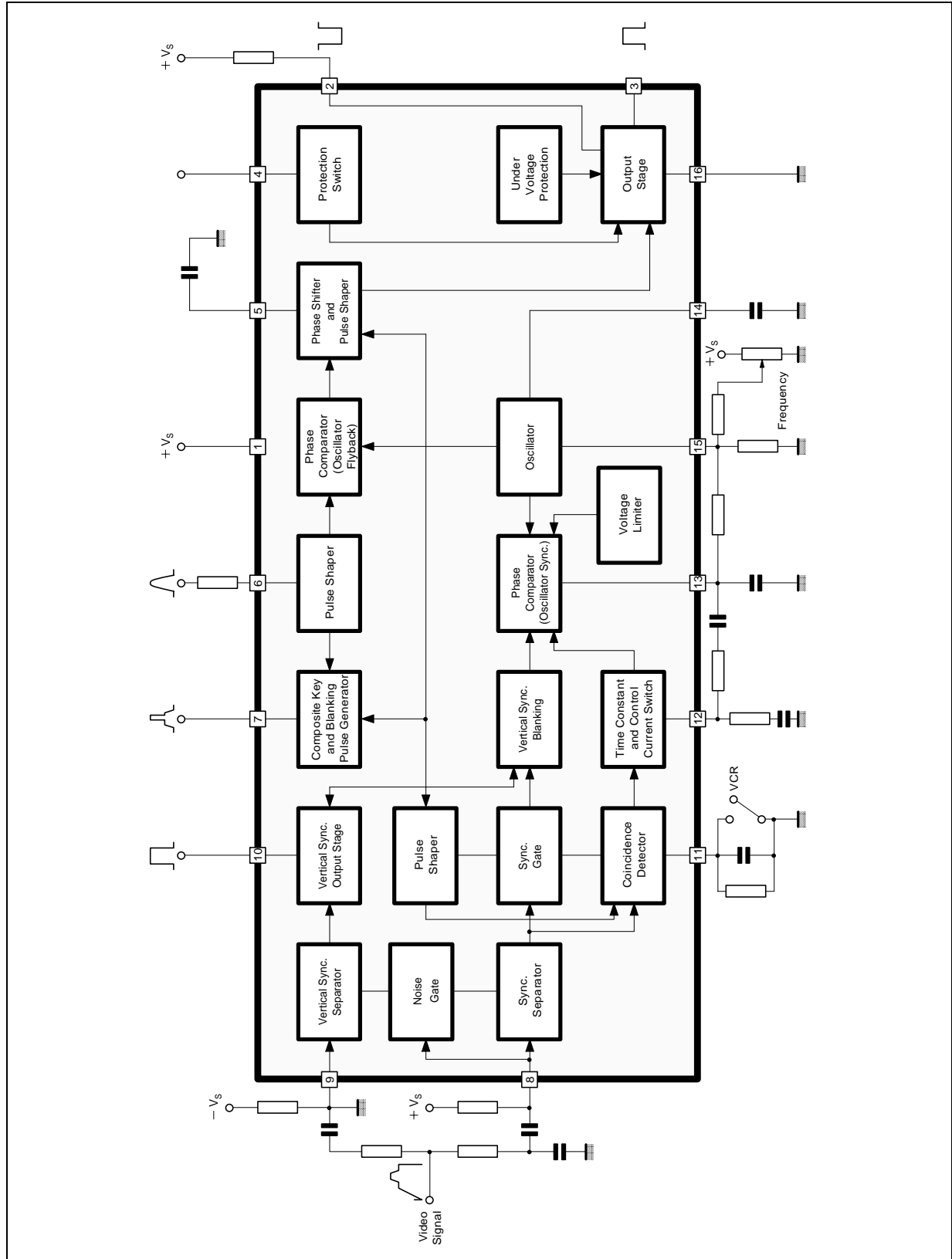

ABSOLUTE MAXIMUM RATINGS

Symbol	Parameter	Value	Unit
V_S	Supply voltage (Pin 1)	15	V
V_2	Voltage at Pin 2	18	V
V_4	Voltage at Pin 4	V_S	
V_8	Voltage at Pin 8	- 6 , V_S	V
V_9	Voltage at Pin 9	± 6	V
V_{11}	Voltage at Pin 11	V_S	
I_2	Pin 2 peak current	1	A
I_3	Pin 3 peak current	0.5	A
I_6	Pin 6 current	30	mA
I_7	Pin 7 current	20	mA
I_{10}	Pin 10 current	30	mA
P_{tot}	Total power dissipation at $T_{amb} \leq 70^\circ\text{C}$	1	W
T_{stg} , T_j	Storage and junction temperature	- 40 , + 150	$^\circ\text{C}$

1180P-01.TBL

THERMAL DATA

Symbol	Parameter	Value	Unit
$R_{th(j-a)}$	Thermal Resistance Junction-Ambient	Max 80	$^\circ\text{C/W}$

1180P-02.TBL

ELECTRICAL CHARACTERISTICS

(refer to the test circuit, $V_S = 12\text{V}$, $T_A = 25^\circ\text{C}$, unless otherwise specified)

Symbol	Parameter	Test conditions	Min.	Typ.	Max.	Unit
V_S	Supply voltage range		9.5	12	13.2	V
I_S	Supply current	$I_3 = 0$		42	52	mA
V_S	Supply voltage at which the output pulses (at pin 2 and 3) are switched off				4	V

HORIZONTAL SYNC. SEPARATOR

V_I	Peak to peak input signal		1	3	6	V
V_8	Input switching voltage	$I_8 = 80 \mu\text{A}$		1.5		V
I_8	Input switching current	$V_8 = 1.4\text{V}$		10		μA
I_8	Leakage current	$V_8 = -5\text{V}$			1	μA

VERTICAL SYNC. SEPARATOR

V_I	Peak to Peak Input Signal		1	3	6	V
V_9	Input Switching Voltage	$I_9 = 80 \mu\text{A}$		1.5		V
I_9	Input Switching Current	$V_9 = 1.4\text{V}$		5		μA
I_9	Leakage Current	$V_9 = -5\text{V}$			1	μA
V_{10}	Vertical Sync. Pulse Output Voltage	No Load Pin10	11			V
R_{10}	Output Resistance			10		$\text{k}\Omega$
t_{LV}	Delay between Leading Edge of Input and Output Signals			17		μs
t_{LV}	Delay between Trailing Edge of Input and Output Signals			50		μs
t_v	Vertical Sync Pulse Duration			190		μs

1180P-03.TBL

TDA1180P

ELECTRICAL CHARACTERISTICS (continued)

(refer to the test circuit, $V_S = 12V$, $T_A = 25^\circ C$, unless otherwise specified)

Symbol	Parameter	Test conditions	Min.	Typ.	Max.	Unit
--------	-----------	-----------------	------	------	------	------

PROTECTION CIRCUIT

V_4	Input Voltage for Switching off the Output Pulses	Output Pulses OFF Output Pulses ON	1		0.5	V
R_4	Input Resistance			200		k Ω
I_4	Input Current		5			μA

FLYBACK PULSE

V_6	Input Threshold Voltage of Blanking Generator			1.8		V
V_6	Input Threshold Voltage of Phase Comparator			7.6		V
I_6	Input Switching Current	$V_6 \geq 1.7V$		0.45		mA

OUTPUT PULSE

V_3	Peak-to-Peak Output Voltage	$I_3 = 150 \text{ mApp}$		10		V
I_3	Output Current	$V_3 = 5V$		500		mA
R_3	Output Resistance	At Leading Edge of output pulse At Trailing Edge of Output Pulse		3 20		Ω Ω
t_p	Output Pulse Duration		20	22	26	μs

COMPOSITE BLANKING AND KEY PULSE

V_{7k}	Key Pulse Output Peak Voltage		9	11		V
V_{7B}	Blanking Pulse Output Voltage		4.2	4.5	4.8	V
R_7	Output Resistance			100		Ω
t_{sk}	Phase Relation Between Trailing Edge of Key Pulse and Middle of Sync. Input Pulse			2.7		μs
t_k	Key Pulse Duration		3.5	3.8		μs
t_{fb}	Delay between Flyback Pulse and Blanking Pulse	$V_6 = 1.7V$			0.2	μs

INTERNAL GATING PULSE

t_g	Gating Pulse Duration			7.5		μs
t	Phase Relation between Middle of Sync. Pulse and Trailing and Leading Edge of Gating Pulse			3.75		μs

COINCIDENCE DETECTOR

V_{11}	Output Voltage	With Coincidence Without Coincidence		6.8	4	V V
I_{11}	Peak Output Current			0.5		mA

VCR SWITCH

V_{11}	Input Voltage			0 to 4 or 8.5 to 12		V
$-I_{11}$	Output Current		35			μA
I_{11}	Output Current		0.4			mA

TIME CONSTANT SWITCH

V_{12}	Output Voltage			3		V
R_{12}	Output Resistance	$4.5V < V_{11} < 8V$ $V_{11} > 8.5V \text{ or } V_{11} < 4V$		100 40		Ω k Ω

1180P-04.TBL

ELECTRICAL CHARACTERISTICS (continued)(refer to the test circuit, $V_S = 12V$, $T_A = 25^\circ C$, unless otherwise specified)

Symbol	Parameter	Test conditions	Min.	Typ.	Max.	Unit
--------	-----------	-----------------	------	------	------	------

OSCILLATOR

V_{14}	Low Level Threshold Voltage			5.4		V
V_{14}	High Level Threshold Voltage			8.2		V
I_{14}	Charge Current			0.6		mA
I_{14}	Discharge Current			0.3		mA
V_{15}	Current Source Supply Voltage			3		V
I_{15}	Current Source Supply Current			0.3		mA
f_0	Free Running Frequency			15625		Hz
$\frac{\Delta f_0}{f_0}$	Adjustment Range			± 10		%
$\frac{\Delta f_0}{\Delta I_{15}}$	Frequency Control Sensitivity			52		$\frac{Hz}{\mu A}$
Δf_0	Frequency Change when V_S Drops to 4V				± 10	%

OSCILLATOR-FLYBACK PULSE PHASE COMPARATOR

V_5	Control Voltage Range		9.4 to 8.2			V
I_5	Peak Control Current		-0.6		+0.6	mA
I_5	Input Current (blocked Phase Detector)				5	μA
t_D	Permissible Delay between Output Pulse Leading Edge and Flyback Pulse Leading Edge			$t_p - t_f$		μs
$\frac{\Delta t}{\Delta t_D}$	Static Control Error				0.2	%

SYNC PULSE-OSCILLATOR PHASE COMPARATOR

V_{13}	Control Voltage Range		4.6 to 1.4			V
I_{13}	Control Peak Current		+2	-2.2	-2	mA
$\frac{\Delta f}{\Delta t}$	Phase Lock Loop Gain			2		$\frac{kHz}{\mu s}$
f	Catching and Holding Range			± 700		Hz

OVERALL PHASE RELATIONSHIP

t_0	Phase Relation between Middle of Flyback Pulse and Middle of Sync. Pulse			2.2		μs
$\frac{\Delta V_5}{\Delta t_0}$	Adjustment Sensitivity			65		$\frac{mV}{\mu s}$
$\frac{\Delta I_5}{\Delta t_0}$	Adjustment Sensitivity			16		$\frac{\mu A}{\mu s}$

1180P-05.TBL

TDA1180P

TEST CIRCUIT

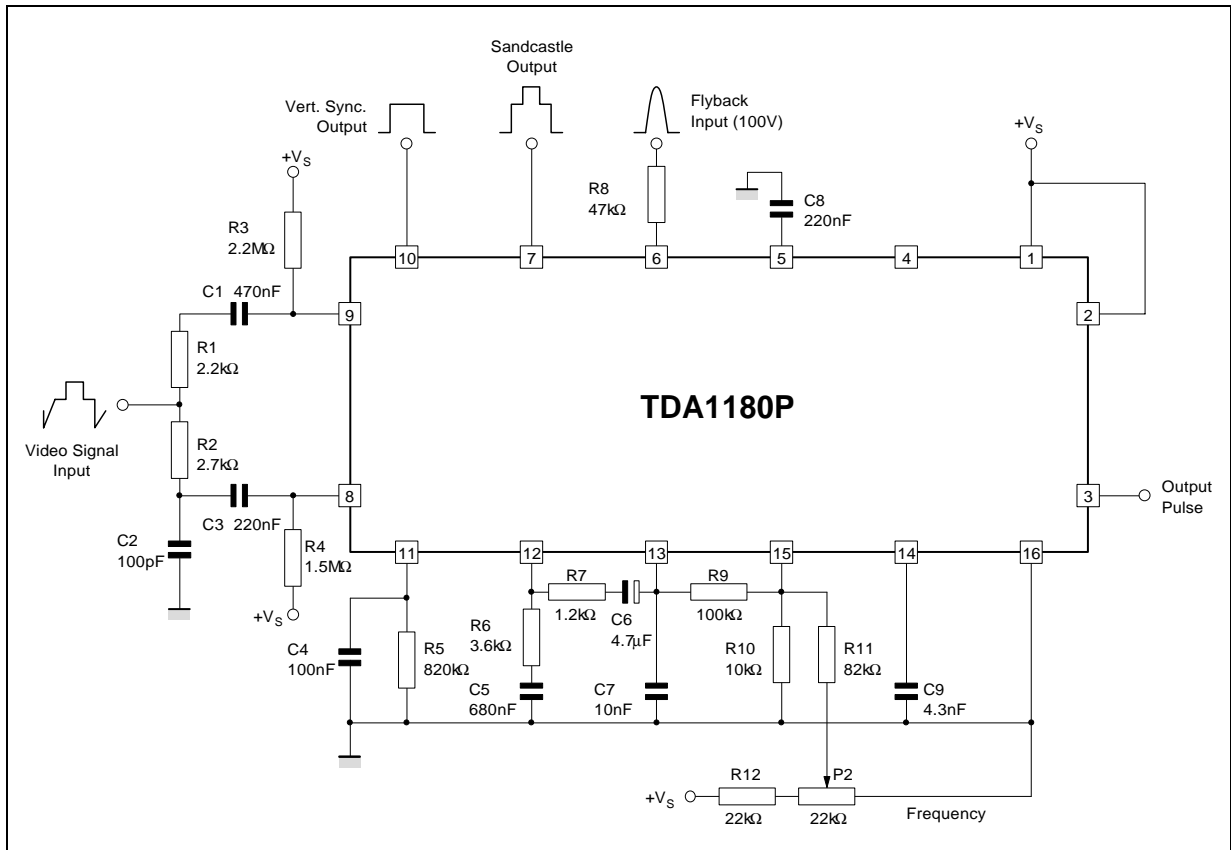

1180P-03.EPS

Figure 1 : Vertical Sync. Output Pulse

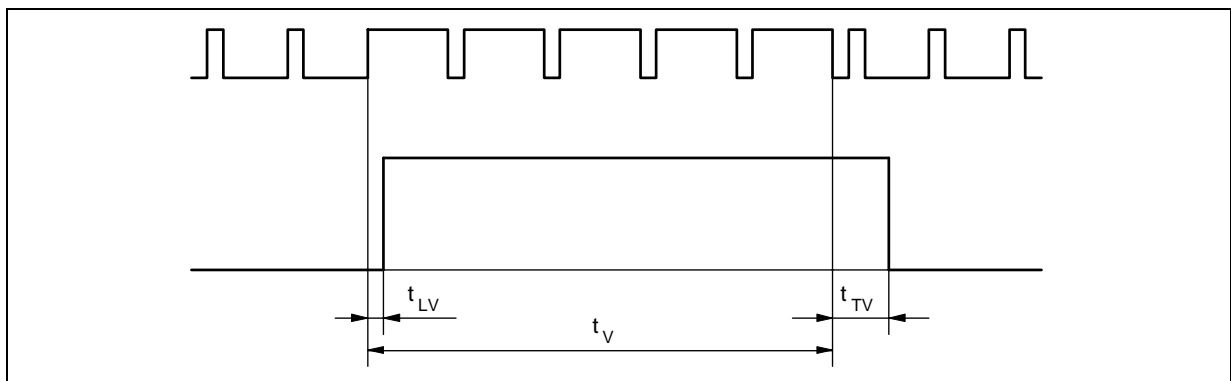

1180P-04.EPS

Figure 2 : Relation Ship of Main Waveform Phases

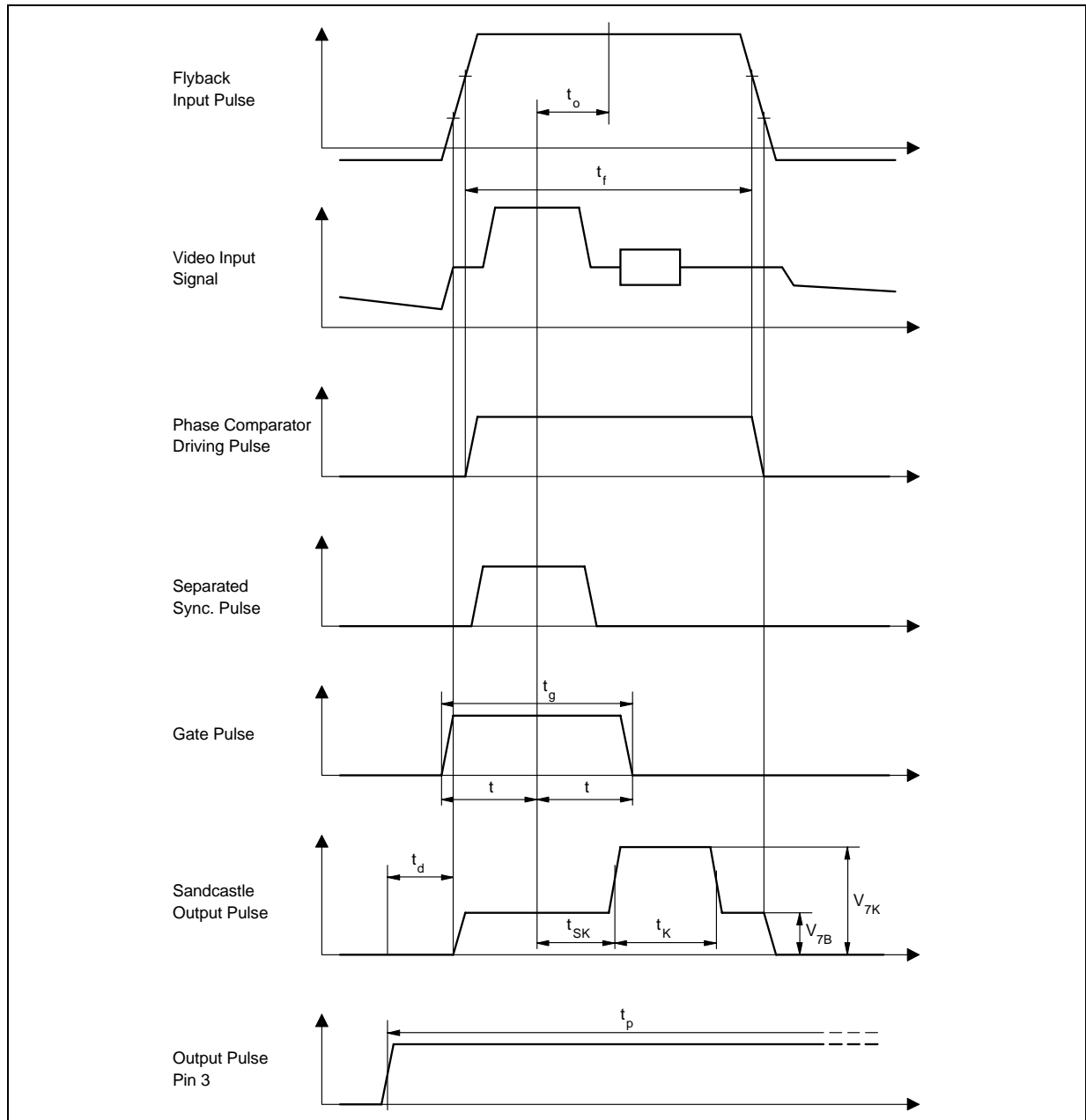

1180P-05.EPS

Figure 3 : Free Running Frequency versus Supply Voltage

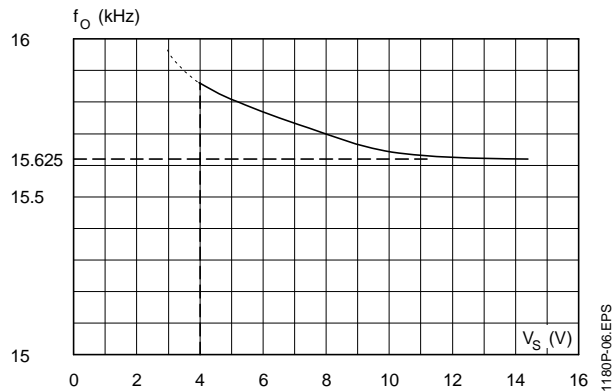
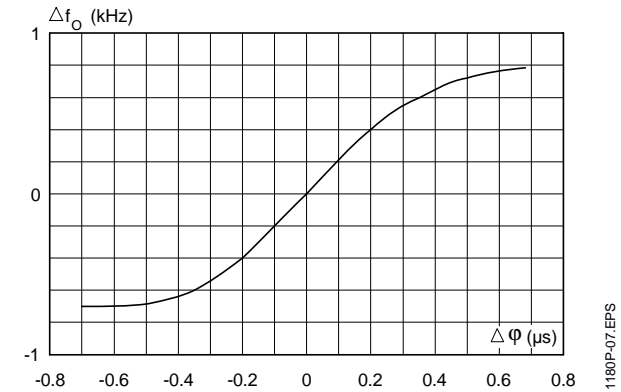

Figure 4 : Loop Gain



APPLICATION INFORMATION

Pin 1 - Positive supply

The operating supply voltage of the device ranges from 10V to 13.2V

Pin 2 and 3 - Output

The outputs of TDA1180P are suitable for driving transistor output stages, they deliver positive pulse at Pin 3 and negative pulse at Pin 2.

The negative pulse is used for direct driving of the output stage, while positive pulse is useful when a driver stage is required.

The rise and fall times of the output pulses are about 150 ns so that interference due to radiation are avoided.

Furthermore the output stages are internally protected against short circuit.

Pin 4 - Protection circuit input

By connecting Pin 4 of the IC to earth the output pulses at Pin 2 and 3 are shut off ; this function has been introduced to protect the final stages from overloads.

The same pulses are also shut off when the supply voltage falls below 4V.

Pin 5 - Phase shifter filter

To compensate for the delay introduced by the line final stages, the flyback pulses to Pin 6 and the oscillator waveform are compared in the oscillator-flyback pulse phase comparator.

The result of the comparison is a control current which, after it has been filtered by the external capacitor connected to Pin 5, is sent to a phase shifter which adequately regulates the phase of the output pulses.

The maximum phase shift allowed is: $t_d = t_p - t_f$ where t_f is the flyback pulse duration.

Pin 5 has high input and output resistance (current generator).

Pin 6 - Flyback input

The flyback pulse drives the high impedance input through a resistor in order to limit the input current to suitable maximum values.

The flyback input pulses are processed by a double threshold circuit; this generates the blanking pulses by sensing low level flyback voltage and the pulses to drive the phase comparator by sensing high level flyback voltage, therefore phase jitter caused by ringing normally associated with the flyback pulse, is avoided.

Pin 7 - Key and blanking pulse output

The key pulse for taking out the burst from the chrominance signal is generated from the oscillator ramp and has therefore a fixed phase position with respect to the sync.

The key pulse is then added internally to the blanking pulse obtained by correctly forming the flyback pulse present at Pin 6.

The sum of the two signals (sandcastle pulse) is available on low impedance at output Pin 7.

Pin 8 and 9 - Sync separators inputs

The video signal is applied by means of two distinct biasing networks to pins 8 and 9 of the IC and therefore to the respective vertical and horizontal sync separators.

The latter take the sync pulses out of the video signal and make them available to the rest of the circuit for further processing.

Pin 10 - Vertical sync output

The vertical sync pulse, obtained by internal integration of the synchronizing signal, is available at this pin.

The output impedance is typically 10k Ω and the lowest amplitude without load is 11V.

Pin 11 - Coincidence detector

From the oscillator waveform a gate pulse 7 μ s wide is taken whose phase position is centered on the horizontal synchronism.

The gate pulse not only controls a logic block which permits the sync to reach the oscillator-sync phase comparator only for as long as its duration, but also allows the latching and de-latching conditions of the oscillator to be established. This function is obtained by a coincidence detector which compares the phase of the gate pulses with that of the sync.

When the two signals are not accurately aligned in time it means that the oscillator is not synchronized. In this case the detector acts on the logic block to eliminate its filtering effect and on the time constant switching block to establish a high impedance on Pin 12 (small time constant of low-pass filter).

This latter block also acts on the oscillator-sync phase detector to increase its sensitivity and with it the loop gain of the synchronizing system.

In this conditions the phase lock has low noise immunity (wide equivalent noise bandwidth) and rapid pull-in time which allows fairly short synchronization times.

Once locking has taken place the coincidence detector enables the logic block, causes a low impedance on Pin 12 and reduces the sensitivity of the phase comparator.

In these conditions the phase lock has high noise immunity (narrow equivalent noise bandwidth) due to the complete elimination of interference which occurs during the scanning period and the greater inertia with which the oscillator can change its frequency.

To optimize the behaviour of the IC if a video

recorder is used, the state of the detector can be forced by connecting Pin 11 to earth or to + V_s . The characteristics of the phase lock thus correspond to the lack of synchronization.

Pin 12 - Time constant switch, (see Pin 11)**Pin 13 - Control current output**

The oscillator is synchronized by comparing the phase of its waveform with that of the sync pulses in the oscillator-sync phase comparator and sending its output current I13 (proportional to the phase difference between the two signals) to Pin 15 of the oscillator after it has been filtered properly with an external low-pass circuit.

The time constant of the filter can be switched between two values according to the impedance presented by Pin 12.

The voltage limiter at the output of the phase comparator limits the voltage excursion on Pin 13 and therefore the frequency range in which the oscillator remains held-in.

The output resistance of Pin 13 is:

- low when $V_{13} > 4.3$ or $V_{13} < 1.6V$
- high when $1.6V < V_{13} < 4.3V$

To prevent the vertical sync from reaching the oscillator-sync phase comparator along with the horizontal sync, a signal which inhibits the phase detector during the vertical interval is taken from the vertical output stage; inhibition remains even if the video signal is not present.

The free running frequency of the oscillator is determined by the values of the capacitor and of the resistor connected to Pins 14 and 15 respectively. To generate the line frequency output pulses, two thresholds are fixed along the fall ramp of the triangular waveform of the oscillator.

Pin14 - Oscillator (see Pin 13)**Pin 15 - Oscillator control current input (see Pin 13)****Pin 16 - Ground**

TDA1180P

Figure 5 : Application Circuit for Large Screen Black & White and Colour TV

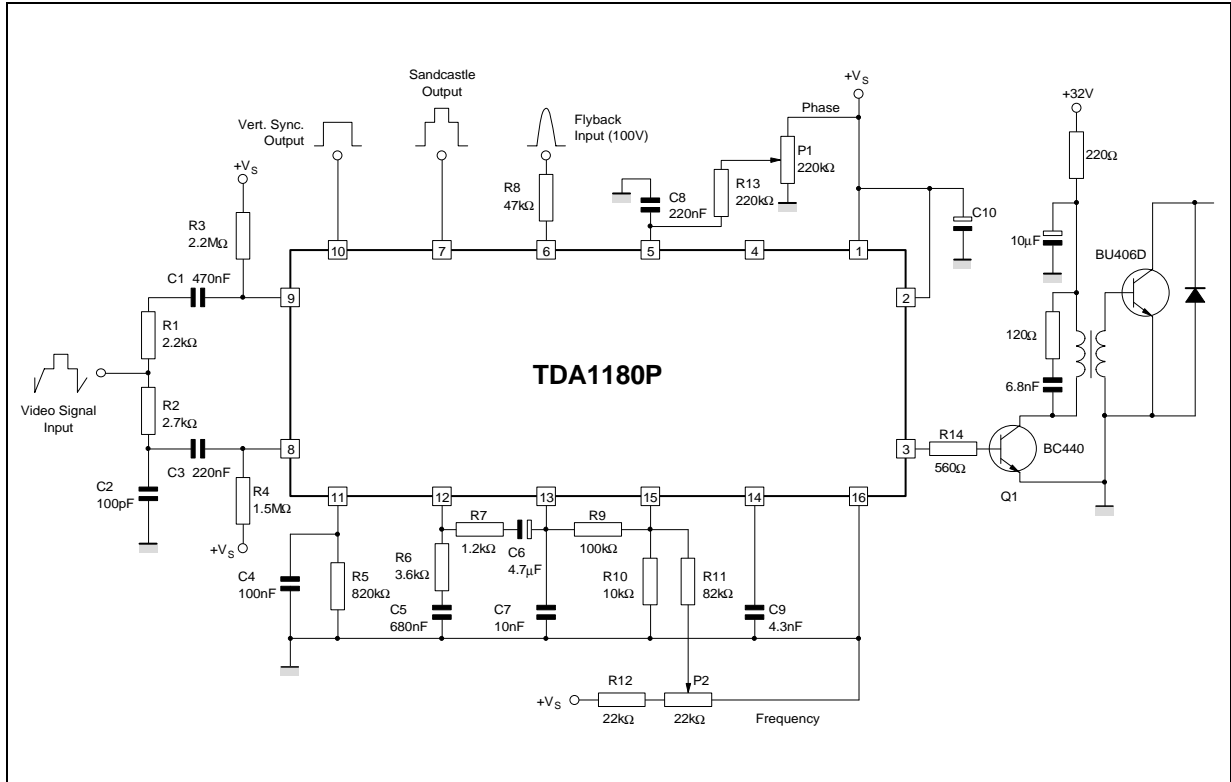

1180P-08.EPS

Figure 6 : P.C. Board and Component Layout for the Circuit in Figure 6 (1:1 scale)

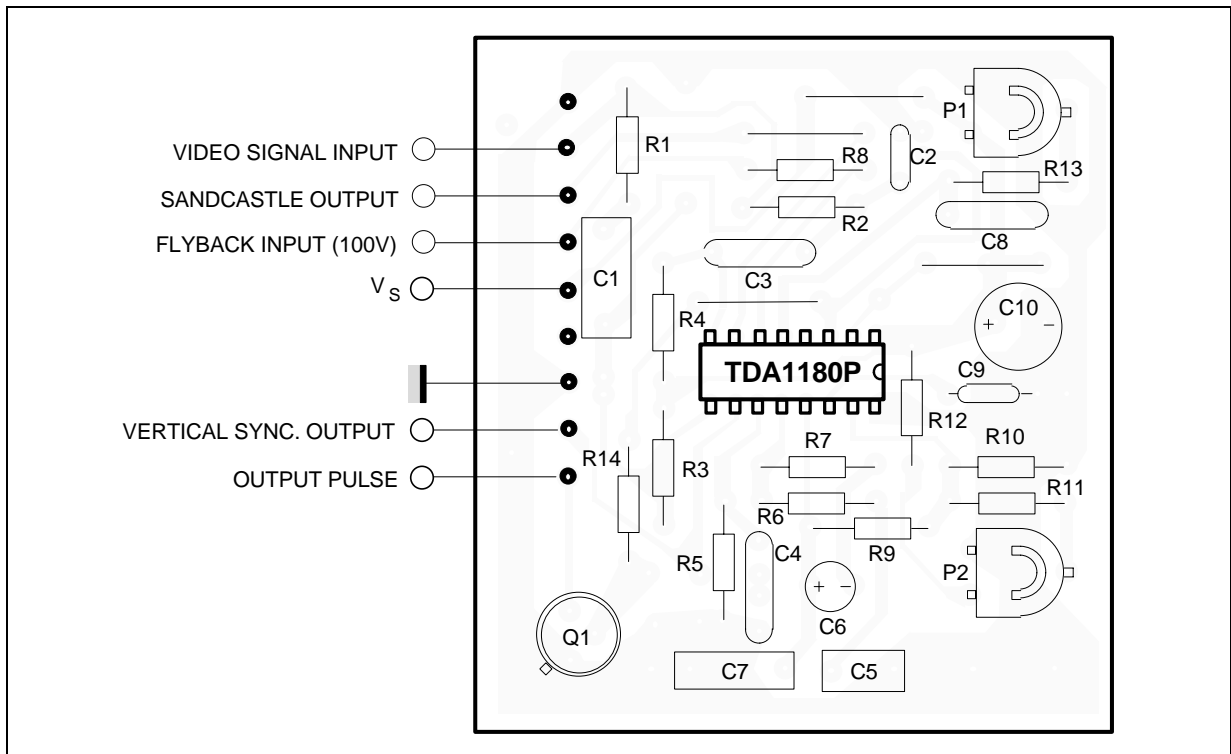

1180P-09.EPS

Figure 7 : Application Circuit for Small Screen b.w. TV

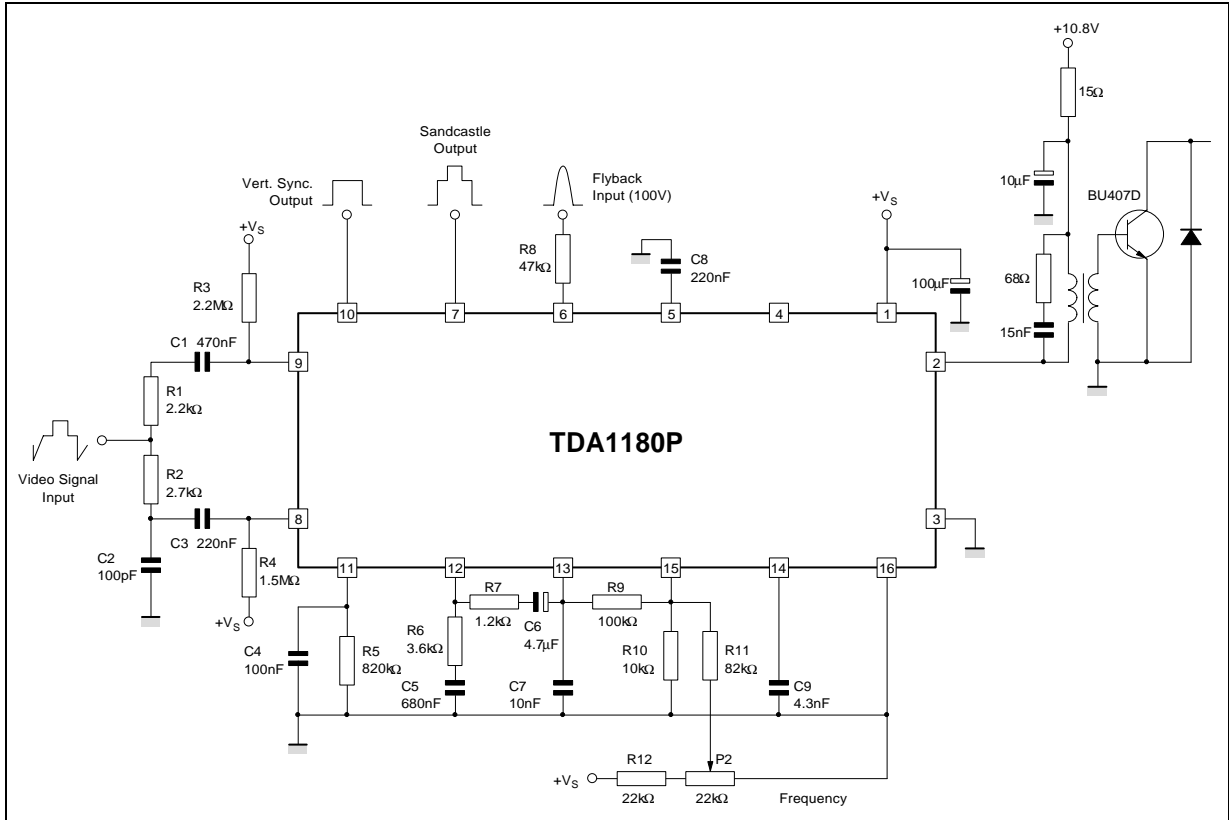

1180P-10.EPS

Figure 8 : Application Circuit for Darlington Output Stage

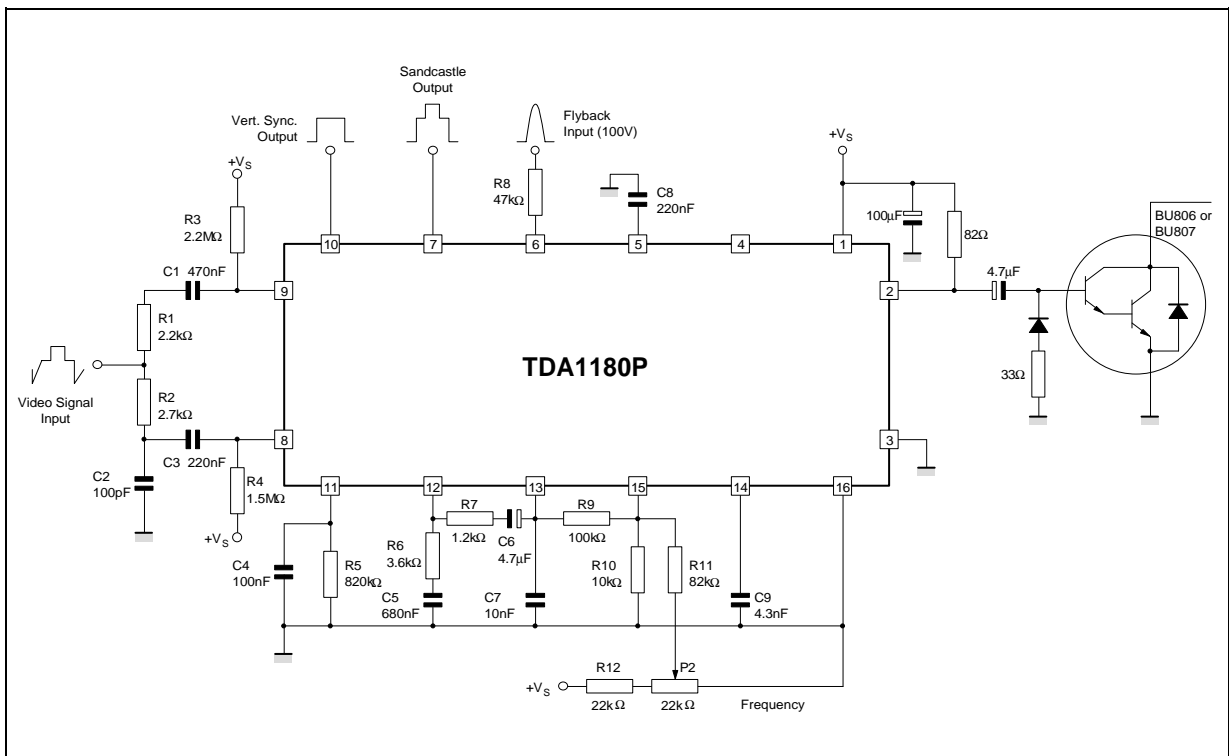

1180P-11.EPS

TDA1180P

PACKAGE MECHANICAL DATA

16 PINS - PLASTIC DIP

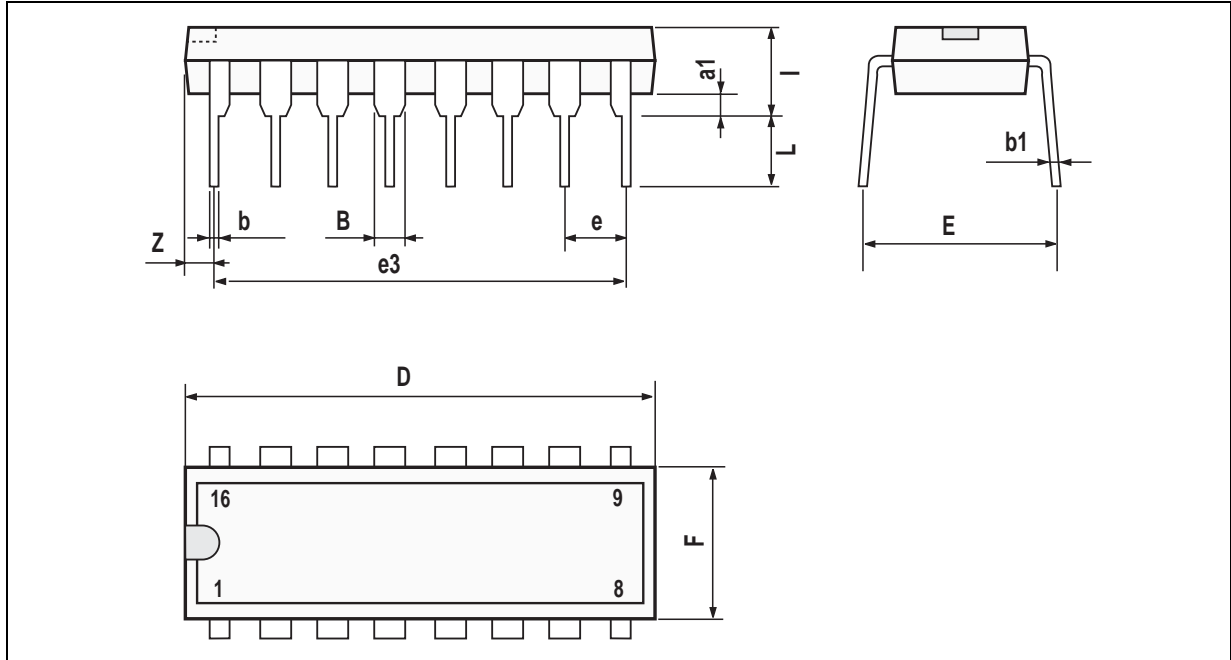

PM-DIP16.EPS

Dimensions	Millimeters			Inches		
	Min.	Typ.	Max.	Min.	Typ.	Max.
a1	0.51			0.020		
B	0.77		1.65	0.030		0.065
b		0.5			0.020	
b1		0.25			0.010	
D			20			0.787
E		8.5			0.335	
e		2.54			0.100	
e3		17.78			0.700	
F			7.1			0.280
i			5.1			0.201
L		3.3			0.130	
Z			1.27			0.050

DIP16.TBL

Information furnished is believed to be accurate and reliable. However, SGS-THOMSON Microelectronics assumes no responsibility for the consequences of use of such information nor for any infringement of patents or other rights of third parties which may result from its use. No licence is granted by implication or otherwise under any patent or patent rights of SGS-THOMSON Microelectronics. Specifications mentioned in this publication are subject to change without notice. This publication supersedes and replaces all information previously supplied. SGS-THOMSON Microelectronics products are not authorized for use as critical components in life support devices or systems without express written approval of SGS-THOMSON Microelectronics.

© 1994 SGS-THOMSON Microelectronics - All Rights Reserved

Purchase of I²C Components of SGS-THOMSON Microelectronics, conveys a license under the Philips I²C Patent. Rights to use these components in a I²C system, is granted provided that the system conforms to the I²C Standard Specifications as defined by Philips.

SGS-THOMSON Microelectronics GROUP OF COMPANIES

Australia - Brazil - China - France - Germany - Hong Kong - Italy - Japan - Korea - Malaysia - Malta - Morocco
The Netherlands - Singapore - Spain - Sweden - Switzerland - Taiwan - Thailand - United Kingdom - U.S.A.