

INTEGRATED CIRCUITS

DATA SHEET

TDA1300T; TDA1300TT Photodetector amplifiers and laser supplies

Preliminary specification
Supersedes data of 1995 Nov 16
File under Integrated Circuits, IC01

1997 Jul 15

Photodetector amplifiers and laser supplies

TDA1300T; TDA1300TT

FEATURES

- Six input buffer amplifiers with low-pass filtering with virtually no offset
- HF data amplifier with a high or low gain mode
- Two built-in equalizers for single or double speed mode ensuring high playability in both modes
- Full automatic laser control including stabilization and an on/off switch and containing a separate supply V_{DDL} for power reduction
- Applicable with N-sub laser with N-sub or P-sub monitor diode
- Adjustable laser bandwidth and laser switch-on current slope
- Protection circuit preventing laser damage due to supply voltage dip
- Optimized interconnect between pick-up detector and TDA1301
- Wide supply voltage range
- Wide temperature range
- Low power consumption.

GENERAL DESCRIPTION

The TDA1300 is an integrated data amplifier and laser supply for three beam pick-up detectors applied in a wide range of mechanisms for Compact Disc (CD) and read only optical systems. It offers 6 amplifiers which amplify and filter the focus and radial diode signals adequately and provides an equalized RF signal for single or double speed mode which can be switched by means of the speed control pin.

The device can handle astigmatic, single Foucault and double Foucault detectors and is applicable with all N-sub lasers and N-sub or P-sub monitor diode units.

After a single initial adjustment the circuit keeps control over the laser diode current resulting in a constant light output power independent of ageing. The chip is mounted in a small SO24 or TSSOP24 package enabling mounting close to the laser pick-up unit on the sledge.

QUICK REFERENCE DATA

SYMBOL	PARAMETER	CONDITIONS	MIN.	TYP.	MAX.	UNIT
V_{DD}	supply voltage		3	–	5.5	V
Diode current amplifiers (n = 1 to 6)						
$G_{d(n)}$	diode current gain		1.43	1.55	1.67	
$I_{O(d)}$	diode offset current		–	–	100	nA
B	3 dB bandwidth	$I_{i(d)} = 1.67 \mu\text{A}$	50	–	–	kHz
RFE amplifier (built-in equalizer)						
$t_{d(eq)}$	equalization delay	$f_i = 0.3 \text{ MHz}$	–	320	–	ns
$t_{d(f)}$	flatness delay	double speed	–	5	–	ns
Laser supply						
$I_{o(L)}$	output current	$V_{DDL} = 3 \text{ V}$	–	–	–100	mA

ORDERING INFORMATION

TYPE NUMBER	PACKAGE		
	NAME	DESCRIPTION	VERSION
TDA1300T	SO24	plastic small outline package; 24 leads; body width 7.5 mm	SOT137-1
TDA1300TT	TSSOP24	plastic thin shrink small outline package; 24 leads; body width 4.4 mm	SOT355-1

Photodetector amplifiers and laser supplies

TDA1300T; TDA1300TT

BLOCK DIAGRAM

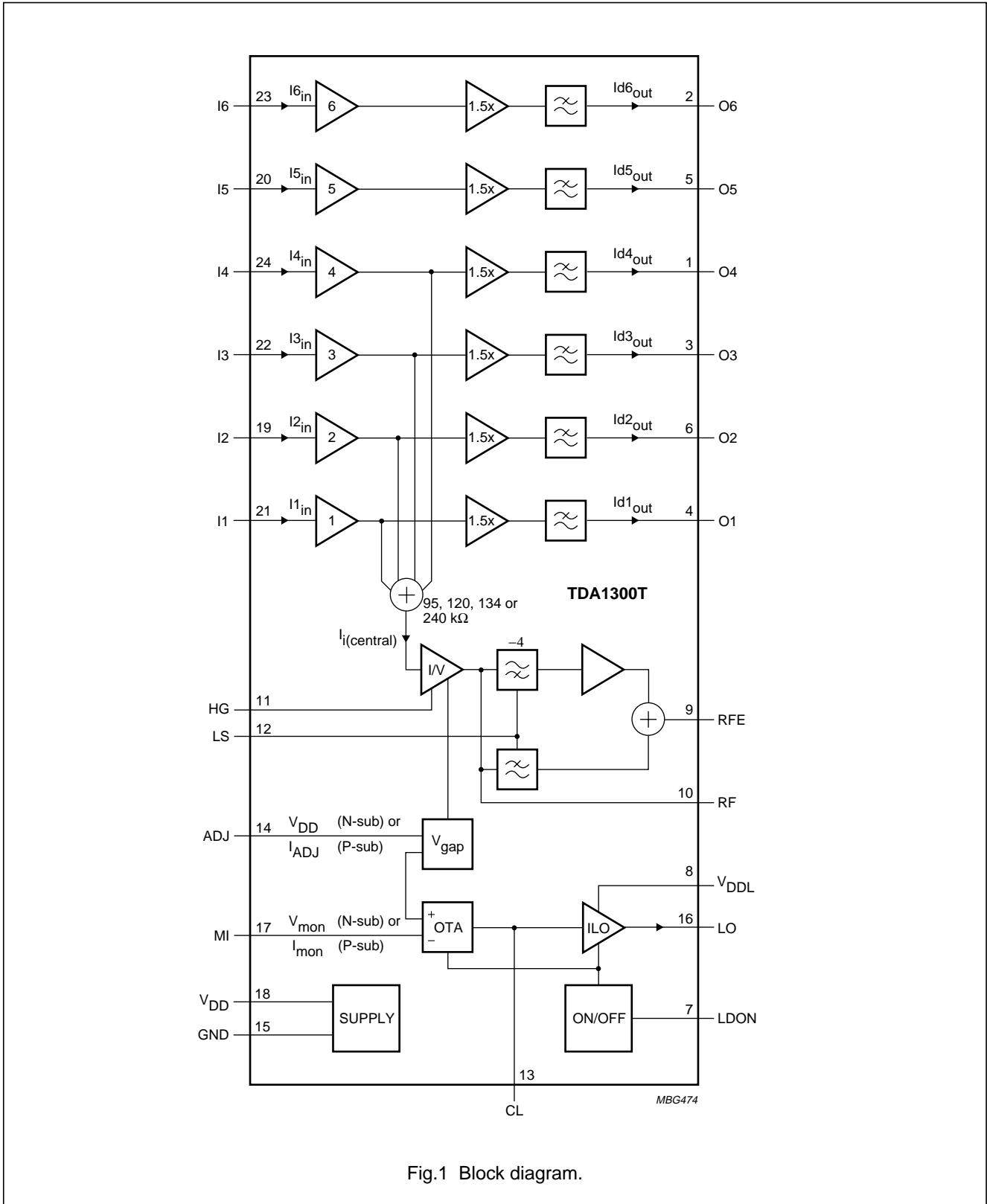

Fig.1 Block diagram.

Photodetector amplifiers and laser supplies

TDA1300T; TDA1300TT

PINNING

SYMBOL	PIN	DESCRIPTION
O4	1	current amplifier 4 output
O6	2	current amplifier 6 output
O3	3	current amplifier 3 output
O1	4	current amplifier 1 output
O5	5	current amplifier 5 output
O2	6	current amplifier 2 output
LDON	7	control pin for switching the laser on and off
V _{DDL}	8	laser supply voltage
RFE	9	equalized output voltage of sum signal of amplifiers 1 to 4
RF	10	unequalized output
HG	11	control pin for gain switch
LS	12	control pin for speed switch
CL	13	external capacitor
ADJ	14	P-sub monitor (if connected via resistor to GND); N-sub monitor (if connected to V _{DD})
GND	15	ground (substrate connection)
LO	16	laser output; current output
MI	17	monitor diode input (laser)
V _{DD}	18	supply
I2	19	photo detector input 2 (central)
I5	20	photo detector input 5 (satellite)
I1	21	photo detector input 1 (central)
I3	22	photo detector input 3 (central)
I6	23	photo detector input 6 (satellite)
I4	24	photo detector input 4 (central)

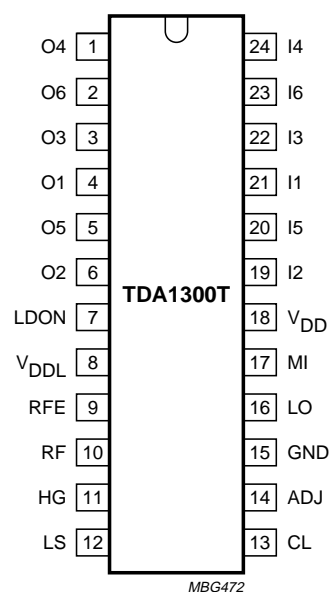

Fig.2 Pin configuration.

Photodetector amplifiers and laser supplies

TDA1300T; TDA1300TT

FUNCTIONAL DESCRIPTION

The TDA1300T; TDA1300TT can be divided into two main sections:

- Laser control circuit section
- Photo diode signal filter and amplification section.

Laser control circuit section

The main function of the laser control circuit is to control the laser diode current in order to achieve a constant light output power. This is done by monitoring the monitor diode. There is a fixed relation between light output power of the laser and the current of the monitor diode. The circuit can handle P-sub or N-sub monitor diodes.

N-sub MONITOR

In this event pin 14 (ADJ) must be connected to the positive supply voltage V_{DD} to select the N-sub mode. With an adjustable resistor (R_{ADJn}) across the diode the monitor current can be adjusted (and so the laser light output power) if one knows that the control circuit keeps the monitor voltage V_{mon} at a constant level of approximately 150 mV.

P-sub MONITOR

In this event pin 14 (ADJ) is connected via resistor R_{ADJp} to ground. The P-sub mode is selected and pin 14 (ADJ) acts as reference band gap voltage, providing together with R_{ADJp} an adjustable current I_{ADJ} . Now the control circuit keeps the monitor current at a level which is $10I_{ADJ}$.

The circuit is built up in three parts:

- The first part is the input stage which is able to switch between both modes (N-sub or P-sub).
- The second part is the integrator part which makes use of an external capacitor C_L . This capacitor has two different functions:

- During switch-on of the laser current, it provides a current slope of typically:

$$\frac{\Delta I_{o(L)}}{\Delta t} \cong \frac{10^{-6}}{C_L} \text{ (A/s)}$$

- After switch-on it ensures that the bandwidth equals

$$B_P \cong \frac{K \times G_{ext} \times 90 \times 10^{-9}}{C_L \times I_{mon}} \text{ (Hz)}$$

in case of P-sub monitor or

$$B_N \cong \frac{R_{ADJn}}{C_L} K \times G_{ext} \times 870 \times 10^{-9} \text{ (Hz)}$$

in case of N-sub monitor, where

G_{ext} represents the AC gain of an extra loop amplifier, if applied, and $K = \Delta I_{mon} / \Delta I_L$ which is determined by the laser/monitor unit. I_{mon} is the average current (pin 17) at typical light emission power of the laser diode.

- The third part is the power output stage, its input being the integrator output signal. This stage has a separate supply voltage (V_{DDL}), thereby offering the possibility of reduced power consumption by supplying this pin with the minimum voltage necessary.

It also has a laser diode protection circuit which comes into action just before the driving output transistor will get saturated due to a large voltage dip on V_{DDL} . Saturation will result in a lower current of the laser diode, which normally is followed immediately by an increment of the voltage of the external capacitor C_L . This could cause damage to the laser diode at the end of the dip. The protection circuit prevents an increment of the capacitor voltage and thus offers full protection to the laser diode under these circumstances.

Photo diode signal filter and amplification section

This section has 6 identical current amplifiers. Amplifiers 1 to 4 are designed to amplify the focus photo diode signals. Each amplifier has two outputs: an LF output and an internal RF output. Amplifiers 5 and 6 are used for the radial photo diode currents and only have an LF output. All 6 output signals are low-pass filtered with a corner frequency at 69 kHz. The internal RF output signals are summed together and converted to a voltage afterwards by means of a selectable transresistance.

This transresistance R_{RF} can be changed between 140 k Ω (3.3 V application) or 240 k Ω (5 V application) in combination with the P-sub monitor. In the event of the N-sub monitor selection, R_{RF} can be changed between 70 k Ω (3.3 V application) and 120 k Ω (5 V application). The RF signal is available directly at pin 10 but there is also an unfiltered signal available at pin 9.

The used equalization filter has 2 different filter curves:

- One for single-speed mode
- One for double-speed mode.

Photodetector amplifiers and laser supplies

TDA1300T; TDA1300TT

Table 1 Gain and monitor modes

PIN		MONITOR MODE	R_{RF} (k Ω)	INTENDED APPLICATION AREA
HG	ADJ			
0	R_{ADJP} connected to ground	P-sub	140	3.3 V
0	1	N-sub	70	
1 ⁽¹⁾	R_{ADJP} connected to ground	P-sub	240	5 V
1 ⁽¹⁾	1	N-sub	120	

Note

- Logic 1 or not connected.

Table 2 Speed and laser modes; note 1

PIN	DEFAULT VALUE ⁽²⁾	MODE			
		SPEED		LASER	
		SINGLE	DOUBLE	on	off
LS	1	1	0	X ⁽³⁾	X ⁽³⁾
LDON	1	X ⁽³⁾	X ⁽³⁾	1	0

Notes

- 1 = HIGH voltage (V_{DD}); 0 = LOW voltage (GND); X = don't care.
- If not connected.
- X = don't care.

LIMITING VALUES

In accordance with the Absolute Maximum Rating System (IEC 134).

SYMBOL	PARAMETER	CONDITIONS	MIN.	MAX.	UNIT
V_{DD}	supply voltage		–	8	V
P_{max}	maximum power dissipation		–	300	mW
T_{stg}	storage temperature		–65	+150	°C
T_{amb}	operating ambient temperature				
	TDA1300T		–40	+85	°C
	TDA1300TT		–40	+70	°C
V_{es} ⁽¹⁾	electrostatic handling pin 16	note 2	–2	+2	kV
	electrostatic handling (all other pins)		–3	+3	kV

Notes

- Classification A: human body model; C = 100 pF; R = 1500 Ω ; $V_{es} = \pm 2000$ V.
Charge device model: C = 200 pF; L = 2.5 μ H; R = 0 Ω ; $V_{es} = 250$ V.
- Equivalent to discharging a 100 pF capacitor through a 1.5 k Ω series resistor.

Photodetector amplifiers and laser supplies

TDA1300T; TDA1300TT

THERMAL CHARACTERISTICS

SYMBOL	PARAMETER	VALUE	UNIT
$R_{th\ j-a}$	thermal resistance from junction to ambient in free air		
	TDA1300T	60	K/W
	TDA1300TT	128	K/W

QUALITY SPECIFICATION

In accordance with "SNW-FQ-611 part E". The numbers of the quality specification can be found in the "Quality Reference Handbook". The handbook can be ordered using the code 9397 750 00192.

CHARACTERISTICS

$V_{DD} = 3.3\text{ V}$; $V_{DDL} = 2.5\text{ V}$; $T_{amb} = 25\text{ °C}$; $R_{ADJ} = 48\text{ k}\Omega$; HG = logic 1; LS = logic 1; with an external low-pass filter ($R_{ext} = 750\ \Omega$; $C_{ext} = 47\text{ pF}$) connected at the RFE output pin.

SYMBOL	PARAMETER	CONDITIONS	MIN.	TYP.	MAX.	UNIT
Supply						
I_{DD}	supply current	laser off	–	7	–	mA
V_{DD}	amplifier supply voltage		3	–	5.5	V
V_{DDL}	laser control supply voltage		2.5	–	5.5	V
P	power dissipation	laser off; $V_{DD} = 3\text{ V}$	–	20	–	mW
Diode current amplifiers (n = 1 to 6; m = 1 to 6)						
$I_{i(d)}$	diode input current	note 1	–	–	10	μA
$I_{n(i)(eq)}$	equivalent noise input current		–	1	–	$\text{pA}/\sqrt{\text{Hz}}$
$V_{i(d)}$	diode input voltage	$I_{i(d)} = 1.67\ \mu\text{A}$	–	0.9	–	V
$V_{o(d)}$	diode output voltage		–0.2	–	$V_{DD} - 1$	V
$G_{d(n)}$	diode current gain	$I_{i(d)} = 1.67\ \mu\text{A}$; $V_{o(d(n))} = 0\text{ V}$; note 2	1.43	1.55	1.67	
$I_{o(d)}$	diode offset current	$I_{i(\text{central})} = I_{i(\text{satellite})} = 0$; note 3	–	–	100	nA
$Z_{o(d)}$	output impedance	$I_{i(d)} = 1.67\ \mu\text{A}$; $V_{o(d(n))} = 0\text{ V}$	500	–	–	$\text{k}\Omega$
B	3 dB bandwidth	$I_{i(d)} = 1.67\ \mu\text{A}$	50	68	–	kHz
G_{mm}	mismatch in gain between amplifiers	$I_{i(d)} = 1.67\ \mu\text{A}$; $V_{o(d(n))} = V_{o(d(m))}$	–	–	3	%

Photodetector amplifiers and laser supplies

TDA1300T; TDA1300TT

SYMBOL	PARAMETER	CONDITIONS	MIN.	TYP.	MAX.	UNIT
Data amplifier; equalized single and double speed						
$V_{O(RF)}$	DC output voltage	$I_{i(\text{central})} = 0$	–	0.3	–	V
R_{RF}	transresistance	N-sub monitor mode (low gain); note 3	56	70	84	k Ω
		N-sub monitor mode (high gain); note 3	96	120	144	k Ω
		P-sub monitor mode (low gain); note 4	112	140	168	k Ω
		P-sub monitor mode (high gain); note 4	200	240	285	k Ω
$V_{O(RF)(\text{max})}$	maximum output voltage	note 5	–	–	$V_{DD} - 1.2$	V
SR_{RF}	RF slew rate	$V_{SR} = 1$ V (peak-to-peak)	–	6	–	V/ μ s
$Z_{o(RF)}$	RF output impedance	$f_i = 1$ MHz	–	100	–	Ω
$t_{d(\text{eq})}$	equalization delay		–	320	–	ns
$t_{d(f)}$	flatness delay (Φ/ω)	LS = 1; note 6	–	10	–	ns
		LS = 0; note 6	–	5	–	ns
G/G	data amplifier gain ratio	note 6	4.5	6	–	dB
B_{RF}	unequalized output bandwidth	$I_{i(d)} = 1.67$ μ A	3	5	–	MHz
Control pins LDON, LS and HG (with 47 kΩ internal pull-up resistor)						
V_{IL}	LOW level input voltage		–0.2	–	+0.5	V
V_{IH}	HIGH level input voltage		$V_{DD} - 1$	–	$V_{DD} + 0.2$	V
I_{IL}	LOW level input current		–	–	100	μ A
Laser output						
$V_{o(L)}$	output voltage	$I_{o(L)} = 100$ mA	–0.2	–	$V_{DDL} - 0.7$	V
$I_{o(L)}$	output current		–	–	–100	mA
$\Delta I_{o(L)}/\Delta t$	slew rate output current	$C_L = 1$ nF (see Fig.8)	–	3.4	–	mA/ μ s
Monitor diode input						
V_{ref}	virtual reference voltage	N-sub monitor mode	130	150	170	mV
I_L	leakage current	N-sub monitor mode	–	1	–	nA
$V_{i(\text{mon})}$	monitor input voltage	P-sub monitor mode	–	$V_{DD} - 0.7$	–	V
$I_{i(\text{mon})}$	monitor input current	P-sub monitor mode	–	–	2	mA
ΔT	reference temperature drift	N-sub monitor mode	–	40	–	ppm
RS_{ref}	reference supply rejection	N-sub monitor mode	–	–	1	%

Photodetector amplifiers and laser supplies

TDA1300T; TDA1300TT

SYMBOL	PARAMETER	CONDITIONS	MIN.	TYP.	MAX.	UNIT
Reference source V_{ADJ} and laser adjustment current I_{ADJ}						
V_{ref}	reference voltage	$R_{ADJ} = 48 \text{ k}\Omega$	1.15	1.24	1.31	mV
ΔT	reference temperature drift		–	40	–	ppm
RS_{ref}	reference supply rejection		–	–	1	%
I_{ADJ}	adjustment current	$R_{ADJ} = 5.6 \text{ k}\Omega$	–	–	200	μA
Z_i	input impedance	$R_{ADJ} = 4.8 \text{ k}\Omega$	–	1	–	$\text{k}\Omega$
M	multiplying factor (I_{mon}/I_{ADJ})		–	10	–	–

Notes to the characteristics

1. The maximum input current is defined as the current in which the gain $G_{d(n)}$ reaches its minimum. Increasing the supply voltage to $V_{DD} = 5 \text{ V}$ increases the maximum input current (see also Figs 4 and 5).
2. The gain increases if a larger supply voltage is used (see Fig.6).
3. Transresistance of $70 \text{ k}\Omega$ and $120 \text{ k}\Omega$ (typical) is only available in N-sub monitor mode (see Table 1).
4. Transresistance of $140 \text{ k}\Omega$ and $240 \text{ k}\Omega$ (typical) is only available in P-sub monitor mode (see Table 1).
5. Output voltage swing will be: $V_{O(RF)(swing)} = V_{O(RF)(max)} - V_{O(RF)(p-p)}$.
6. For single speed the data amplifier gain ratio is defined as gain difference between 1 MHz and 100 kHz , while the flatness delay is defined up to 1 MHz (see Fig.7). For double speed the data amplifier gain ratio is defined as gain difference between 2 MHz and 200 kHz , while the flatness delay is defined up to 2 MHz .

Photodetector amplifiers and laser supplies

TDA1300T; TDA1300TT

Transfer functions; see Fig.6

The equalized amplifier including C_{ext} and R_{ext} has the following transfer functions, where 'RFE' refers to equalized output only and 'RF' refers to equalized and not equalized outputs.

FOR SINGLE SPEED (SP = LOGIC 1)

$$\frac{V_{\text{RFE}}}{I_{i(\text{central})}} = R_{\text{RF}} \times \frac{(1 - ks^2)/\omega_{\text{os}}^2}{1 + 1/Q \times s/\omega_{\text{os}} + s^2/\omega_{\text{os}}^2} \times \frac{1}{1 + s/\omega_1} \times \frac{1}{1 + sR_{\text{ext}} \times C_{\text{ext}}} \quad (1)$$

FOR DOUBLE SPEED (SP = LOGIC 0)

$$\frac{V_{\text{RFE}}}{I_{i(\text{central})}} = R_{\text{RF}} \times \frac{(1 - ks^2)/\omega_{\text{os}}^2}{1 + 1/Q \times s/\omega_{\text{od}} + s^2/\omega_{\text{od}}^2} \times \frac{1}{1 + sR_{\text{ext}} \times C_{\text{ext}}} \quad (2)$$

The denominator forms the denominator of a Bessel low-pass filter.

Symbols used in equations (1) and (2) are explained in Table 3.

Table 3 Transresistance

SYMBOL	DESCRIPTION	TYP.	UNIT
k	internally defined	4	
$\omega_{\text{os}}/\omega_1$	internally defined	1.094	
Q	internally defined	0.691	
$\omega_{\text{od}} = 2 \times \omega_{\text{os}}$	internally defined	17.6×10^{-6}	rad/s
R_{RF}	see Chapter "Characteristics"	–	
R_{ext}	external resistor	750	Ω
C_{ext}	external capacitor	47	pF

Photodetector amplifiers and laser supplies

TDA1300T; TDA1300TT

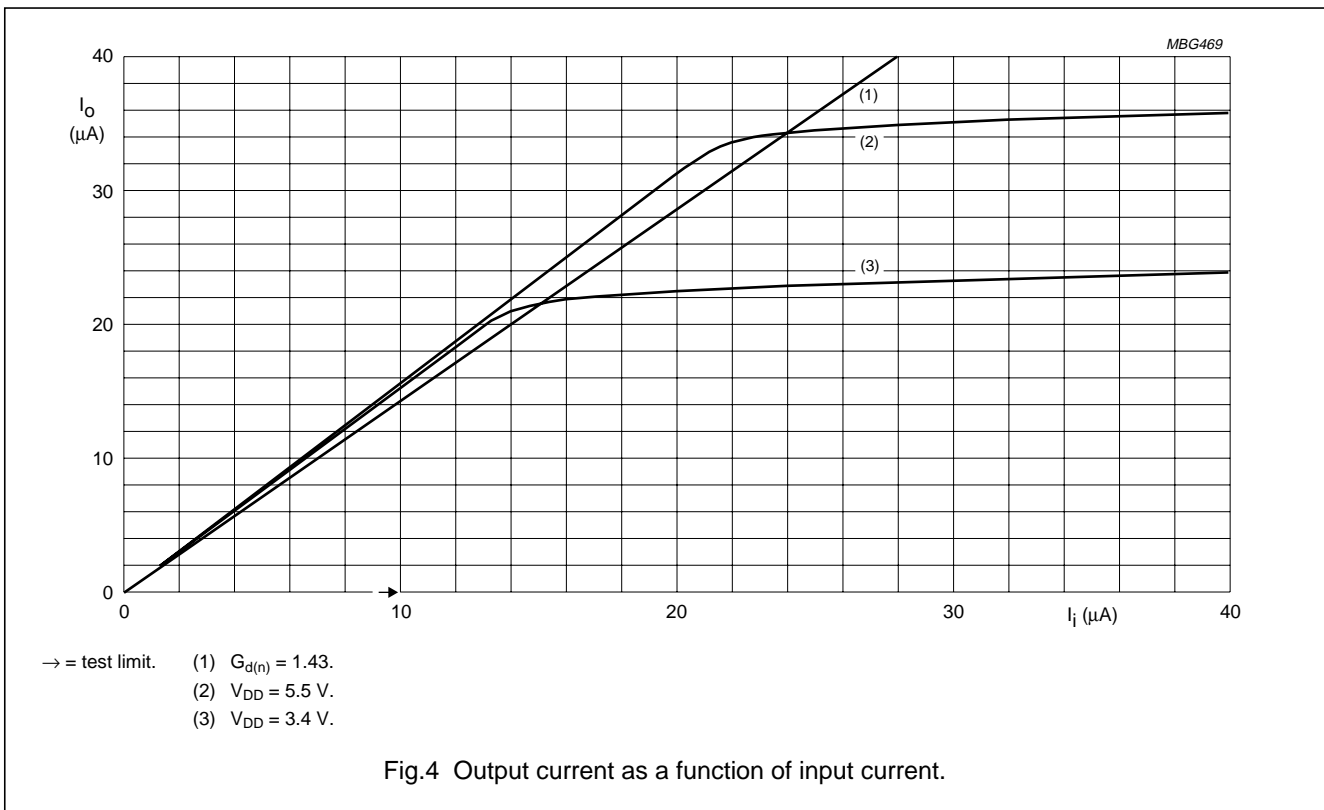
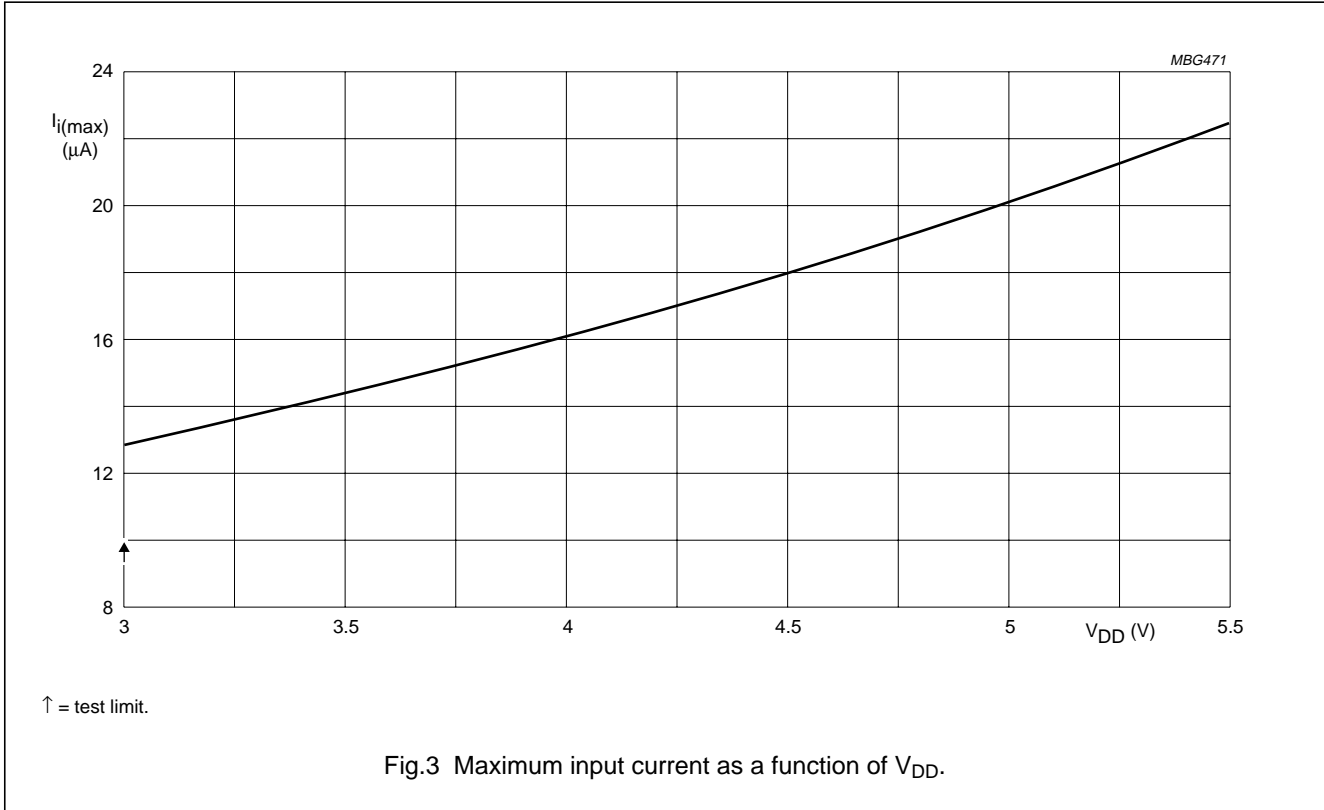

Photodetector amplifiers and laser supplies

TDA1300T; TDA1300TT

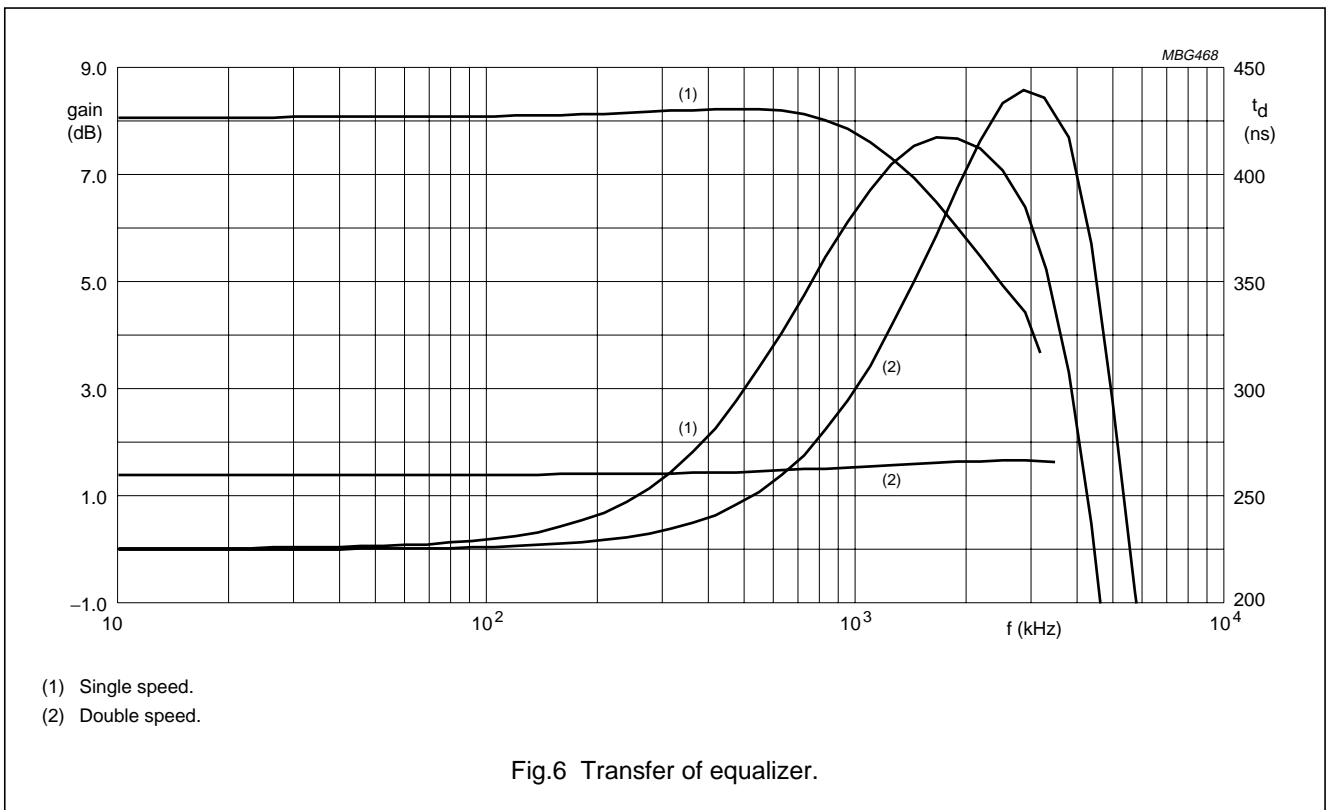
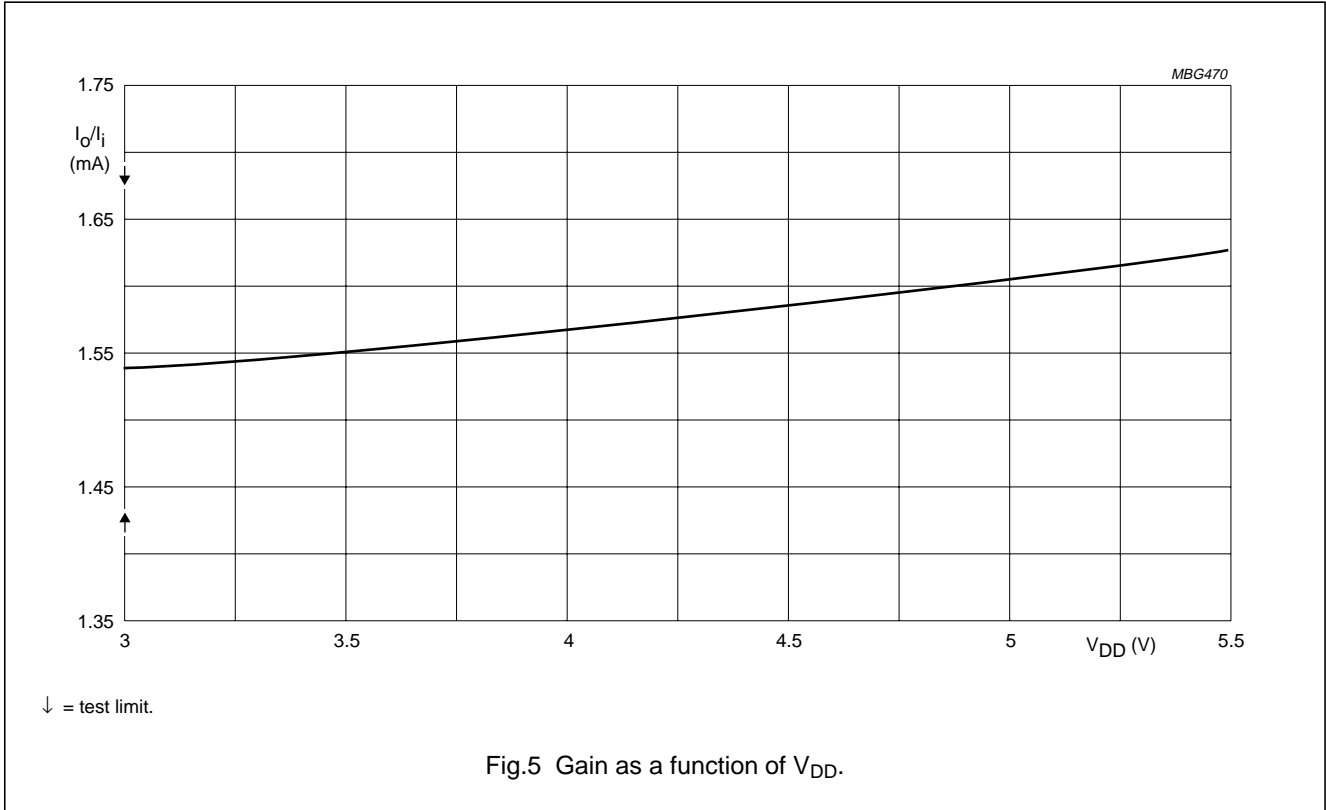

Photodetector amplifiers and laser supplies

TDA1300T; TDA1300TT

INTERNAL PIN CONFIGURATION

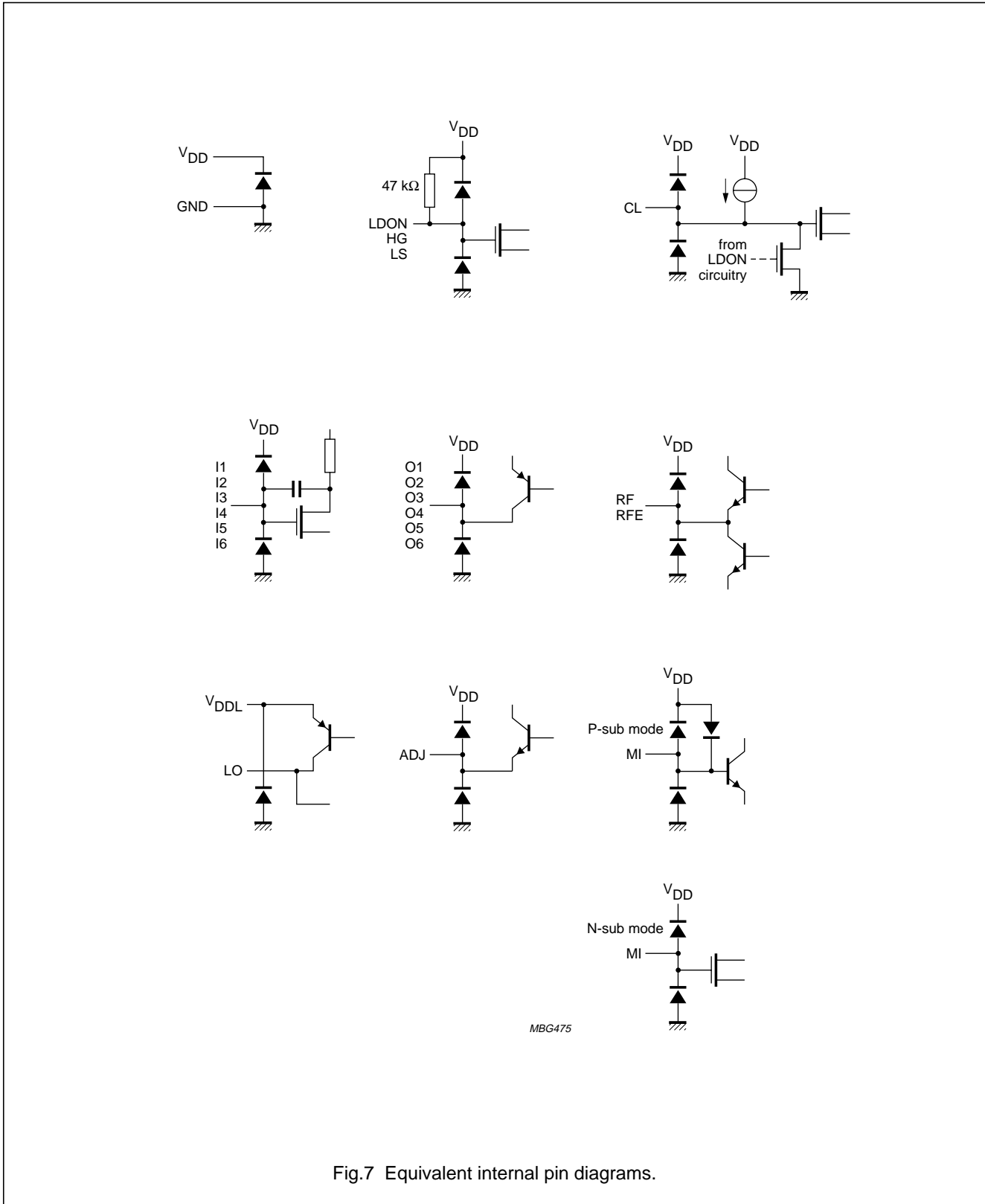

Fig.7 Equivalent internal pin diagrams.

Photodetector amplifiers and laser supplies

TDA1300T; TDA1300TT

APPLICATION INFORMATION

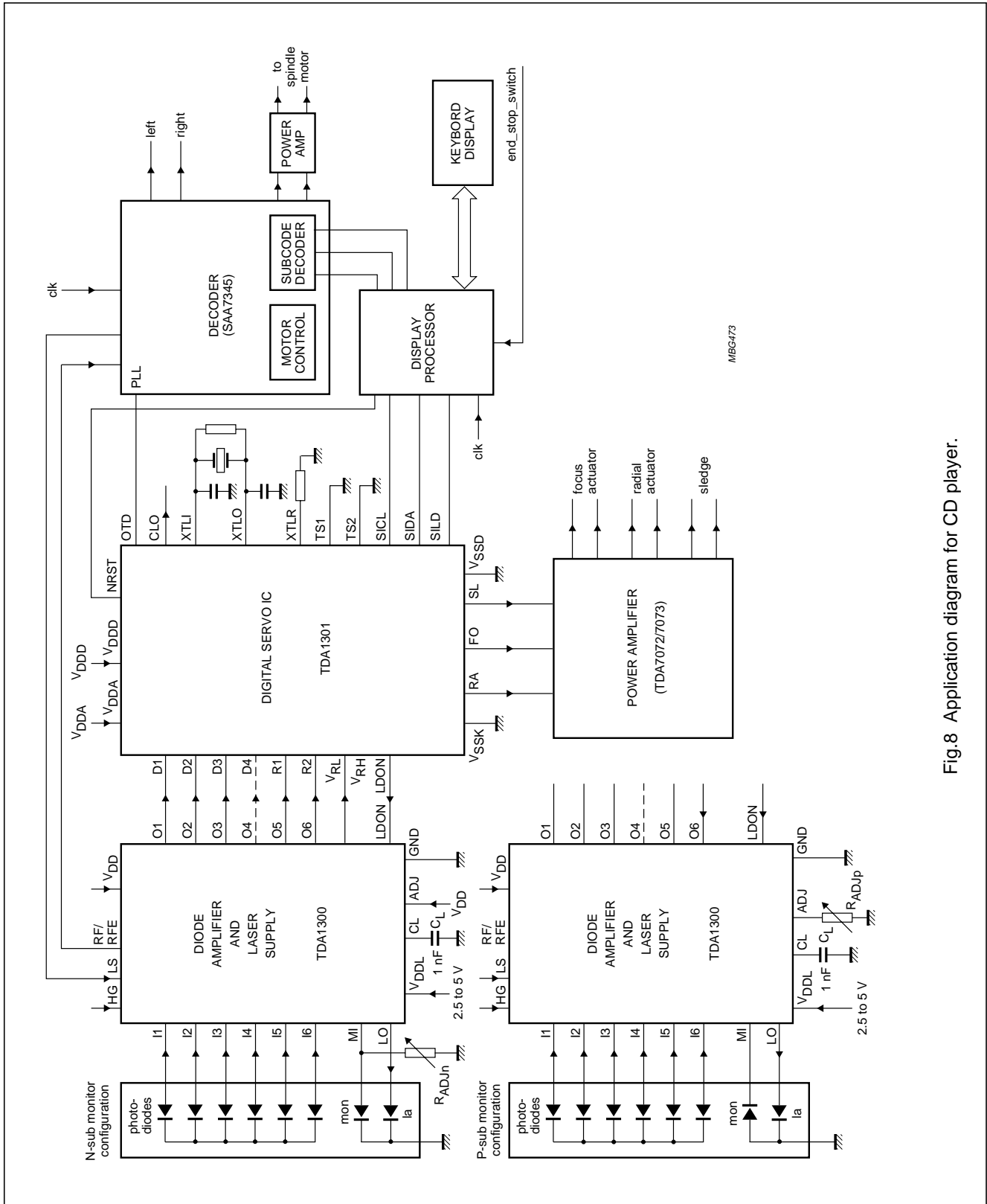

Fig.8 Application diagram for CD player.

Photodetector amplifiers and laser supplies

TDA1300T; TDA1300TT

PACKAGE OUTLINES

SO24: plastic small outline package; 24 leads; body width 7.5 mm

SOT137-1

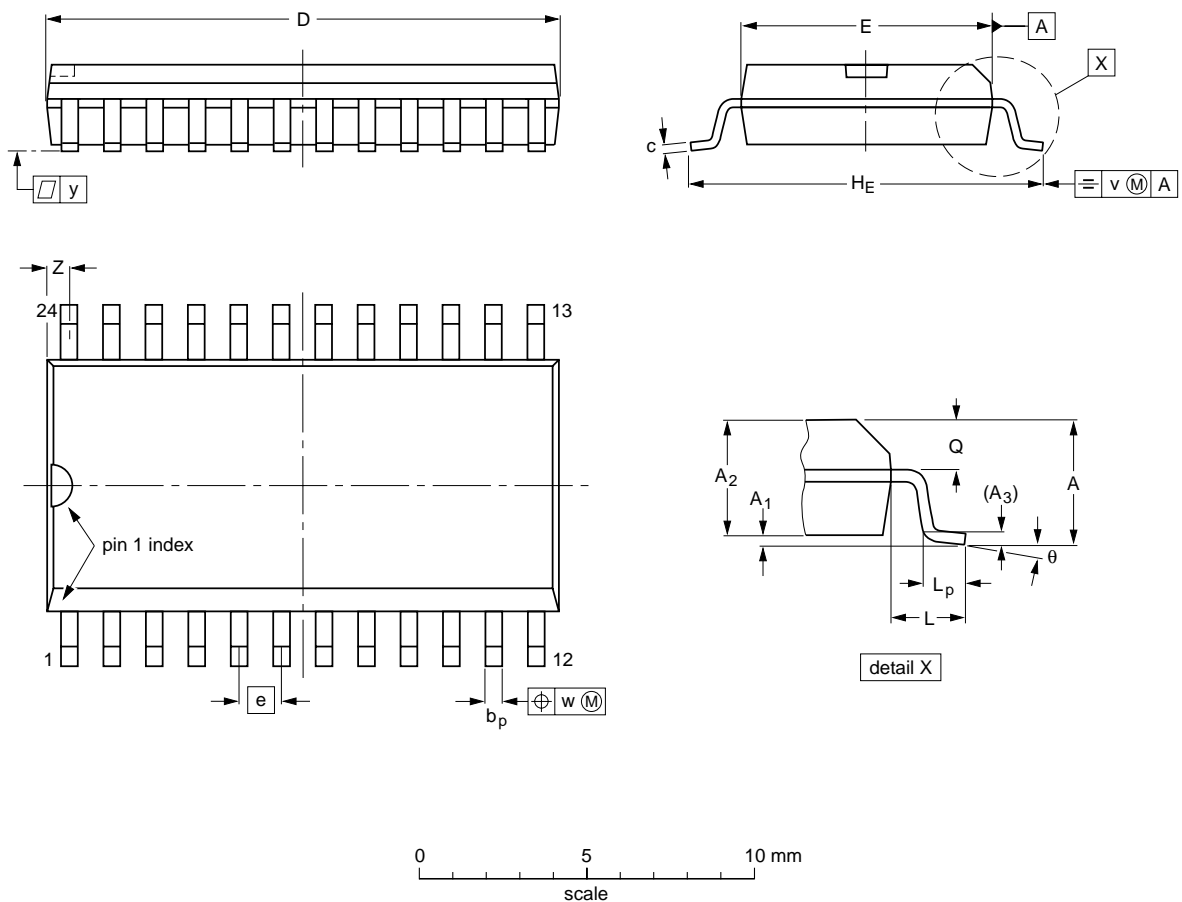

DIMENSIONS (inch dimensions are derived from the original mm dimensions)

UNIT	A max.	A ₁	A ₂	A ₃	b _p	c	D ⁽¹⁾	E ⁽¹⁾	e	H _E	L	L _p	Q	v	w	y	z ⁽¹⁾	θ
mm	2.65	0.30 0.10	2.45 2.25	0.25	0.49 0.36	0.32 0.23	15.6 15.2	7.6 7.4	1.27	10.65 10.00	1.4	1.1 0.4	1.1 1.0	0.25	0.25	0.1	0.9 0.4	8° 0°
inches	0.10	0.012 0.004	0.096 0.089	0.01	0.019 0.014	0.013 0.009	0.61 0.60	0.30 0.29	0.050	0.419 0.394	0.055	0.043 0.016	0.043 0.039	0.01	0.01	0.004	0.035 0.016	

Note

1. Plastic or metal protrusions of 0.15 mm maximum per side are not included.

OUTLINE VERSION	REFERENCES			EUROPEAN PROJECTION	ISSUE DATE
	IEC	JEDEC	EIAJ		
SOT137-1	075E05	MS-013AD			95-01-24 97-05-22

Photodetector amplifiers and laser supplies

TDA1300T; TDA1300TT

TSSOP24: plastic thin shrink small outline package; 24 leads; body width 4.4 mm

SOT355-1

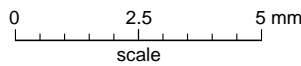
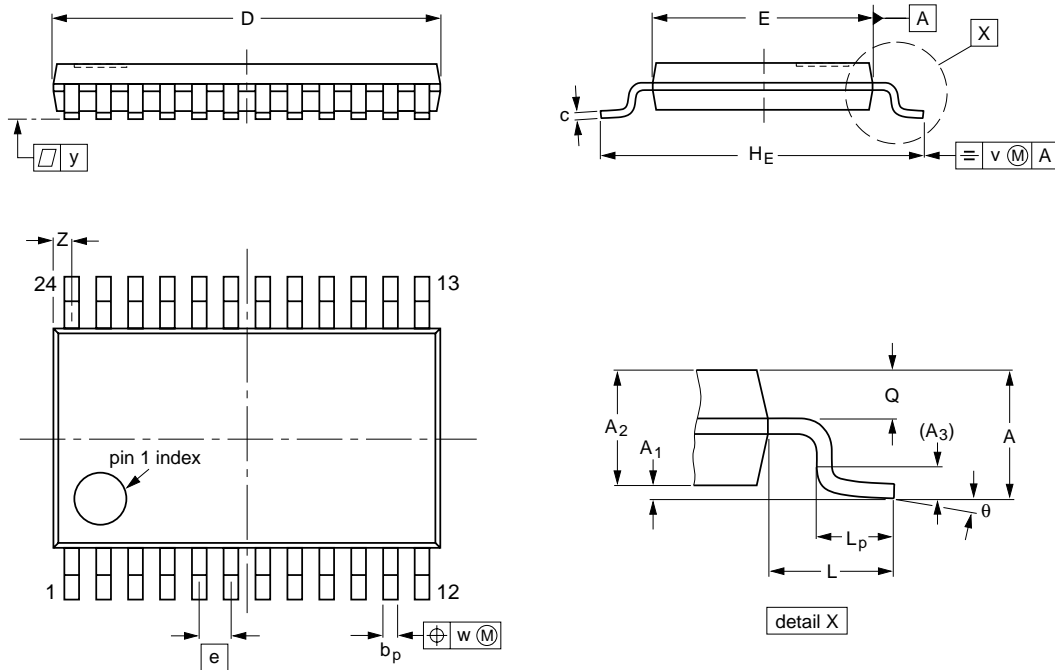

DIMENSIONS (mm are the original dimensions)

UNIT	A max.	A ₁	A ₂	A ₃	b _p	c	D ⁽¹⁾	E ⁽²⁾	e	H _E	L	L _p	Q	v	w	y	z ⁽¹⁾	θ
mm	1.10	0.15 0.05	0.95 0.80	0.25	0.30 0.19	0.2 0.1	7.9 7.7	4.5 4.3	0.65	6.6 6.2	1.0	0.75 0.50	0.4 0.3	0.2	0.13	0.1	0.5 0.2	8° 0°

Notes

1. Plastic or metal protrusions of 0.15 mm maximum per side are not included.
2. Plastic interlead protrusions of 0.25 mm maximum per side are not included.

OUTLINE VERSION	REFERENCES				EUROPEAN PROJECTION	ISSUE DATE
	IEC	JEDEC	EIAJ			
SOT355-1		MO-153AD				93-06-16 95-02-04

Photodetector amplifiers and laser supplies

TDA1300T; TDA1300TT

SOLDERING

Introduction

There is no soldering method that is ideal for all IC packages. Wave soldering is often preferred when through-hole and surface mounted components are mixed on one printed-circuit board. However, wave soldering is not always suitable for surface mounted ICs, or for printed-circuits with high population densities. In these situations reflow soldering is often used.

This text gives a very brief insight to a complex technology. A more in-depth account of soldering ICs can be found in our "IC Package Databook" (order code 9398 652 90011).

Reflow soldering

Reflow soldering techniques are suitable for all SO and TSSOP packages.

Reflow soldering requires solder paste (a suspension of fine solder particles, flux and binding agent) to be applied to the printed-circuit board by screen printing, stencilling or pressure-syringe dispensing before package placement.

Several techniques exist for reflowing; for example, thermal conduction by heated belt. Dwell times vary between 50 and 300 seconds depending on heating method. Typical reflow temperatures range from 215 to 250 °C.

Preheating is necessary to dry the paste and evaporate the binding agent. Preheating duration: 45 minutes at 45 °C.

Wave soldering

SO

Wave soldering techniques can be used for all SO packages if the following conditions are observed:

- A double-wave (a turbulent wave with high upward pressure followed by a smooth laminar wave) soldering technique should be used.
- The longitudinal axis of the package footprint must be parallel to the solder flow.
- The package footprint must incorporate solder thieves at the downstream end.

TSSOP

Wave soldering is **not** recommended for TSSOP packages. This is because of the likelihood of solder bridging due to closely-spaced leads and the possibility of incomplete solder penetration in multi-lead devices.

If wave soldering cannot be avoided, the following conditions must be observed:

- **A double-wave (a turbulent wave with high upward pressure followed by a smooth laminar wave) soldering technique should be used.**
- **The longitudinal axis of the package footprint must be parallel to the solder flow and must incorporate solder thieves at the downstream end.**

Even with these conditions, do not consider wave soldering TSSOP packages with 48 leads or more, that is TSSOP48 (SOT362-1) and TSSOP56 (SOT364-1).

METHOD (SO AND TSSOP)

During placement and before soldering, the package must be fixed with a droplet of adhesive. The adhesive can be applied by screen printing, pin transfer or syringe dispensing. The package can be soldered after the adhesive is cured.

Maximum permissible solder temperature is 260 °C, and maximum duration of package immersion in solder is 10 seconds, if cooled to less than 150 °C within 6 seconds. Typical dwell time is 4 seconds at 250 °C.

A mildly-activated flux will eliminate the need for removal of corrosive residues in most applications.

Repairing soldered joints

Fix the component by first soldering two diagonally-opposite end leads. Use only a low voltage soldering iron (less than 24 V) applied to the flat part of the lead. Contact time must be limited to 10 seconds at up to 300 °C. When using a dedicated tool, all other leads can be soldered in one operation within 2 to 5 seconds between 270 and 320 °C.

Photodetector amplifiers and laser supplies

TDA1300T; TDA1300TT

DEFINITIONS

Data sheet status	
Objective specification	This data sheet contains target or goal specifications for product development.
Preliminary specification	This data sheet contains preliminary data; supplementary data may be published later.
Product specification	This data sheet contains final product specifications.
Limiting values	
Limiting values given are in accordance with the Absolute Maximum Rating System (IEC 134). Stress above one or more of the limiting values may cause permanent damage to the device. These are stress ratings only and operation of the device at these or at any other conditions above those given in the Characteristics sections of the specification is not implied. Exposure to limiting values for extended periods may affect device reliability.	
Application information	
Where application information is given, it is advisory and does not form part of the specification.	

LIFE SUPPORT APPLICATIONS

These products are not designed for use in life support appliances, devices, or systems where malfunction of these products can reasonably be expected to result in personal injury. Philips customers using or selling these products for use in such applications do so at their own risk and agree to fully indemnify Philips for any damages resulting from such improper use or sale.

Photodetector amplifiers and laser
supplies

TDA1300T; TDA1300TT

NOTES

Philips Semiconductors – a worldwide company

Argentina: see South America

Australia: 34 Waterloo Road, NORTH RYDE, NSW 2113,
Tel. +61 2 9805 4455, Fax. +61 2 9805 4466

Austria: Computerstr. 6, A-1101 WIEN, P.O. Box 213, Tel. +43 160 1010,
Fax. +43 160 101 1210

Belarus: Hotel Minsk Business Center, Bld. 3, r. 1211, Volodarski Str. 6,
220050 MINSK, Tel. +375 172 200 733, Fax. +375 172 200 773

Belgium: see The Netherlands

Brazil: see South America

Bulgaria: Philips Bulgaria Ltd., Energoproject, 15th floor,
51 James Bourchier Blvd., 1407 SOFIA,
Tel. +359 2 689 211, Fax. +359 2 689 102

Canada: PHILIPS SEMICONDUCTORS/COMPONENTS,
Tel. +1 800 234 7381

China/Hong Kong: 501 Hong Kong Industrial Technology Centre,
72 Tat Chee Avenue, Kowloon Tong, HONG KONG,
Tel. +852 2319 7888, Fax. +852 2319 7700

Colombia: see South America

Czech Republic: see Austria

Denmark: Prags Boulevard 80, PB 1919, DK-2300 COPENHAGEN S,
Tel. +45 32 88 2636, Fax. +45 31 57 0044

Finland: Sinikalliontie 3, FIN-02630 ESPOO,
Tel. +358 9 615800, Fax. +358 9 61580920

France: 4 Rue du Port-aux-Vins, BP317, 92156 SURESNES Cedex,
Tel. +33 1 40 99 6161, Fax. +33 1 40 99 6427

Germany: Hammerbrookstraße 69, D-20097 HAMBURG,
Tel. +49 40 23 53 60, Fax. +49 40 23 536 300

Greece: No. 15, 25th March Street, GR 17778 TAVROS/ATHENS,
Tel. +30 1 4894 339/239, Fax. +30 1 4814 240

Hungary: see Austria

India: Philips INDIA Ltd, Band Box Building, 2nd floor,
254-D, Dr. Annie Besant Road, Worli, MUMBAI 400 025,
Tel. +91 22 493 8541, Fax. +91 22 493 0966

Indonesia: see Singapore

Ireland: Newstead, Clonskeagh, DUBLIN 14,
Tel. +353 1 7640 000, Fax. +353 1 7640 200

Israel: RAPAC Electronics, 7 Kehilat Saloniki St, PO Box 18053,
TEL AVIV 61180, Tel. +972 3 645 0444, Fax. +972 3 649 1007

Italy: PHILIPS SEMICONDUCTORS, Piazza IV Novembre 3,
20124 MILANO, Tel. +39 2 6752 2531, Fax. +39 2 6752 2557

Japan: Philips Bldg 13-37, Kohnan 2-chome, Minato-ku, TOKYO 108,
Tel. +81 3 3740 5130, Fax. +81 3 3740 5077

Korea: Philips House, 260-199 Itaewon-dong, Yongsan-ku, SEOUL,
Tel. +82 2 709 1412, Fax. +82 2 709 1415

Malaysia: No. 76 Jalan Universiti, 46200 PETALING JAYA, SELANGOR,
Tel. +60 3 750 5214, Fax. +60 3 757 4880

Mexico: 5900 Gateway East, Suite 200, EL PASO, TEXAS 79905,
Tel. +9-5 800 234 7381

Middle East: see Italy

Netherlands: Postbus 90050, 5600 PB EINDHOVEN, Bldg. VB,
Tel. +31 40 27 82785, Fax. +31 40 27 88399

New Zealand: 2 Wagener Place, C.P.O. Box 1041, AUCKLAND,
Tel. +64 9 849 4160, Fax. +64 9 849 7811

Norway: Box 1, Manglerud 0612, OSLO,
Tel. +47 22 74 8000, Fax. +47 22 74 8341

Philippines: Philips Semiconductors Philippines Inc.,
106 Valero St. Salcedo Village, P.O. Box 2108 MCC, MAKATI,
Metro MANILA, Tel. +63 2 816 6380, Fax. +63 2 817 3474

Poland: Ul. Lukiska 10, PL 04-123 WARSZAWA,
Tel. +48 22 612 2831, Fax. +48 22 612 2327

Portugal: see Spain

Romania: see Italy

Russia: Philips Russia, Ul. Usatcheva 35A, 119048 MOSCOW,
Tel. +7 095 755 6918, Fax. +7 095 755 6919

Singapore: Lorong 1, Toa Payoh, SINGAPORE 1231,
Tel. +65 350 2538, Fax. +65 251 6500

Slovakia: see Austria

Slovenia: see Italy

South Africa: S.A. PHILIPS Pty Ltd., 195-215 Main Road Martindale,
2092 JOHANNESBURG, P.O. Box 7430 Johannesburg 2000,
Tel. +27 11 470 5911, Fax. +27 11 470 5494

South America: Rua do Rocio 220, 5th floor, Suite 51,
04552-903 São Paulo, SÃO PAULO - SP, Brazil,
Tel. +55 11 821 2333, Fax. +55 11 829 1849

Spain: Balmes 22, 08007 BARCELONA,
Tel. +34 3 301 6312, Fax. +34 3 301 4107

Sweden: Kottbygatan 7, Akalla, S-16485 STOCKHOLM,
Tel. +46 8 632 2000, Fax. +46 8 632 2745

Switzerland: Allmendstrasse 140, CH-8027 ZÜRICH,
Tel. +41 1 488 2686, Fax. +41 1 481 7730

Taiwan: Philips Semiconductors, 6F, No. 96, Chien Kuo N. Rd., Sec. 1,
TAIPEI, Taiwan Tel. +886 2 2134 2865, Fax. +886 2 2134 2874

Thailand: PHILIPS ELECTRONICS (THAILAND) Ltd.,
209/2 Sanpavuth-Bangna Road Prakanong, BANGKOK 10260,
Tel. +66 2 745 4090, Fax. +66 2 398 0793

Turkey: Talatpasa Cad. No. 5, 80640 GÜLTEPE/ISTANBUL,
Tel. +90 212 279 2770, Fax. +90 212 282 6707

Ukraine: PHILIPS UKRAINE, 4 Patrice Lumumba str., Building B, Floor 7,
252042 KIEV, Tel. +380 44 264 2776, Fax. +380 44 268 0461

United Kingdom: Philips Semiconductors Ltd., 276 Bath Road, Hayes,
MIDDLESEX UB3 5BX, Tel. +44 181 730 5000, Fax. +44 181 754 8421

United States: 811 East Arques Avenue, SUNNYVALE, CA 94088-3409,
Tel. +1 800 234 7381

Uruguay: see South America

Vietnam: see Singapore

Yugoslavia: PHILIPS, Trg N. Pasica 5/v, 11000 BEOGRAD,
Tel. +381 11 625 344, Fax. +381 11 635 777

For all other countries apply to: Philips Semiconductors, Marketing & Sales Communications,
Building BE-p, P.O. Box 218, 5600 MD EINDHOVEN, The Netherlands, Fax. +31 40 27 24825

Internet: <http://www.semiconductors.philips.com>

© Philips Electronics N.V. 1997

SCA55

All rights are reserved. Reproduction in whole or in part is prohibited without the prior written consent of the copyright owner.

The information presented in this document does not form part of any quotation or contract, is believed to be accurate and reliable and may be changed without notice. No liability will be accepted by the publisher for any consequence of its use. Publication thereof does not convey nor imply any license under patent- or other industrial or intellectual property rights.

Printed in The Netherlands

547027/50/03/pp20

Date of release: 1997 Jul 15

Document order number: 9397 750 01673

Let's make things better.

Philips



PHILIPS