

**INTEGRATED CIRCUITS**

# DATA SHEET

## **TDA1312A; TDA1312AT** Stereo continuous calibration DAC (CC-DAC)

Preliminary specification  
File under Integrated Circuits, IC01

July 1993

## Stereo continuous calibration DAC (CC-DAC)

## TDA1312A; TDA1312AT

### FEATURES

- 8 × oversampling (simultaneous input) possible
- Voltage output
- Space saving package SO8 or DIL8
- Low power consumption
- Wide dynamic range (16-bit resolution)
- Continuous Calibration (CC) concept
- Easy application:
  - single 4 to 5.5 V rail supply
  - output current and bias current are proportional to the supply voltage
  - integrated current-to-voltage converter
- Internal bias current ensures maximum dynamic range
- Wide operating temperature range (−40 °C to +85 °C)
- Compatible with most current Japanese input formats: time multiplexed, two's complement and TTL
- No zero-crossing distortion
- Cost efficient.

### ORDERING INFORMATION

EXTENDED TYPE NUMBER	PACKAGE			
	PINS	PIN POSITION	MATERIAL	CODE
TDA1312A <sup>(1)</sup>	8	DIL	plastic	SOT97DE
TDA1312AT <sup>(2)</sup>	8	SO8	plastic	SOT96AG

### Notes

1. SOT97-1; 1996 August 14.
2. SOT96-1; 1996 August 14.

### GENERAL DESCRIPTION

The TDA1312A; 1312AT is a voltage driven D/A converter and is a device of a new generation of digital-to-analog converters which embodies the innovative technique of Continuous Calibration (CC). The largest bit-currents are repeatedly generated by one single current reference source. This duplication is based upon an internal charge storage principle having an accuracy insensitive to ageing, temperature matching and process variations.

The TDA1312A; 1312AT is fabricated in a 1.0 μm CMOS process and features an extremely low power dissipation, small package size and easy application. Furthermore, the accuracy of the intrinsic high coarse-current combined with the implemented symmetrical offset decoding method preclude zero-crossing distortion and ensures high quality audio reproduction. Therefore, the CC-DAC is eminently suitable for use in (portable) digital audio equipment.

## Stereo continuous calibration DAC (CC-DAC)

TDA1312A; TDA1312AT

### QUICK REFERENCE DATA

SYMBOL	PARAMETER	CONDITIONS	MIN.	TYP.	MAX.	UNIT
$V_{DD}$	supply voltage		4	5	5.5	V
$I_{DD}$	supply current	$V_{DD} = 5\text{ V}$ ; at code 0000H	–	3.4	6.0	mA
$V_{FS}$	full scale output voltage	$V_{DD} = 5\text{ V}$	1.8	2.0	2.2	V
(THD+N)/S	total harmonic distortion plus noise	at 0 dB signal level	–	–68	–63	dB
			–	0.04	0.07	%
		at –60 dB signal level	–	–30	–24	dB
			–	3	6	%
at –60 dB signal level; A-weighted	–	–33	–	dB		
	–	2	–	%		
S/N	signal-to-noise ratio at bipolar zero	A-weighted; at code 0000H	86	92	–	dB
$t_{CS}$	current settling time to $\pm 1$ LSB		–	0.2	–	$\mu\text{s}$
BR	input bit rate at data input		–	–	18.4	Mbits/s
$f_{BCK}$	clock frequency at clock input		–	–	18.4	MHz
$TC_{FS}$	full scale temperature coefficient at analog outputs ( $I_{OL}$ ; $I_{OR}$ )		–	$\pm 400$	–	ppm
$T_{amb}$	operating ambient temperature		–40	–	+85	$^{\circ}\text{C}$
$P_{tot}$	total power dissipation	$V_{DD} = 5\text{ V}$ ; at code 0000H	–	17	30	mW

# Stereo continuous calibration DAC (CC-DAC)

## TDA1312A; TDA1312AT

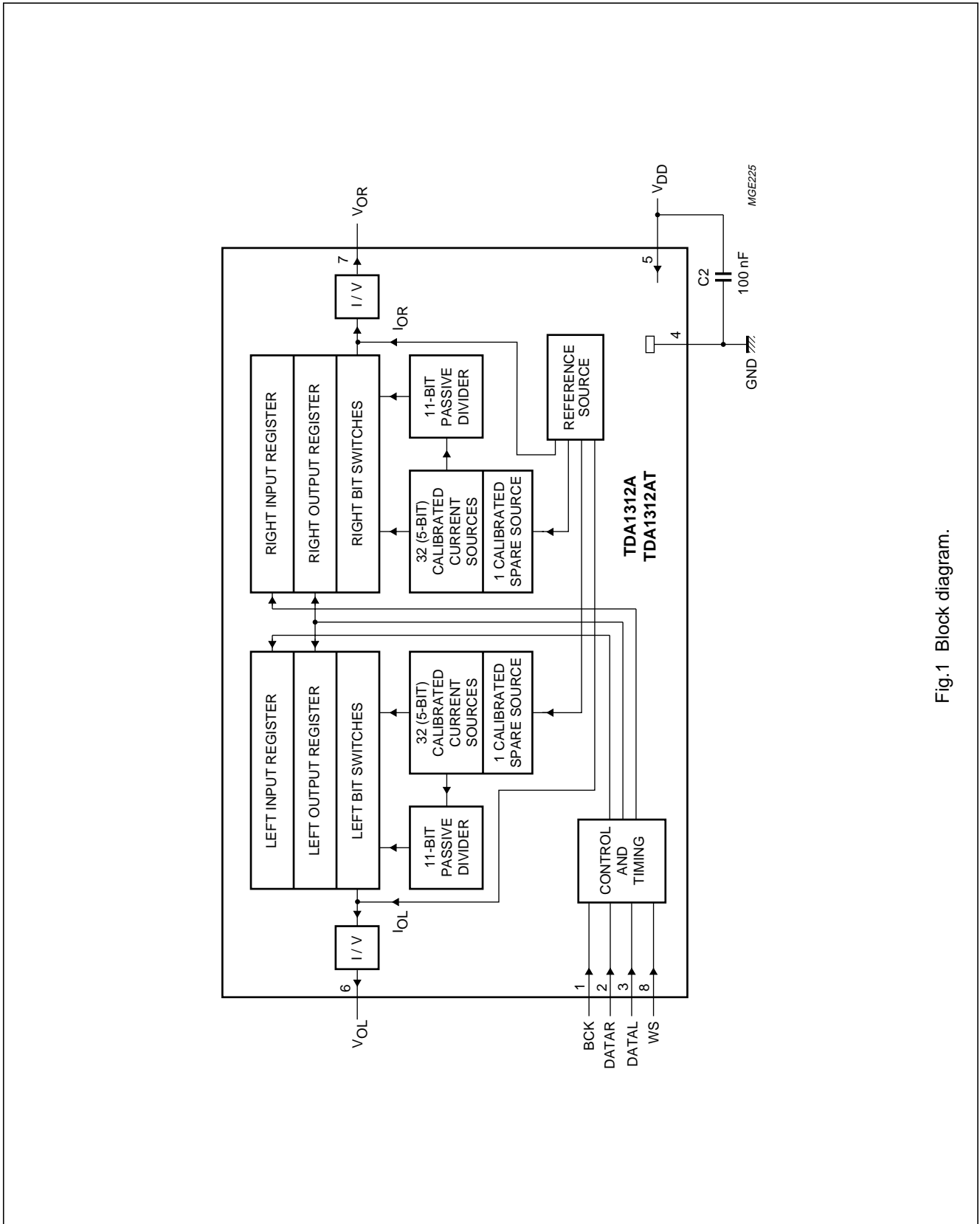

Fig.1 Block diagram.

## Stereo continuous calibration DAC (CC-DAC)

### TDA1312A; TDA1312AT

#### PINNING

SYMBOL	PIN	DESCRIPTION
BCK	1	bit clock input
DATAR	2	right data input
DATAL	3	left data input
GND	4	ground
V <sub>DD</sub>	5	positive supply voltage
V <sub>OL</sub>	6	left channel output
V <sub>OR</sub>	7	right channel output
WS	8	word select input

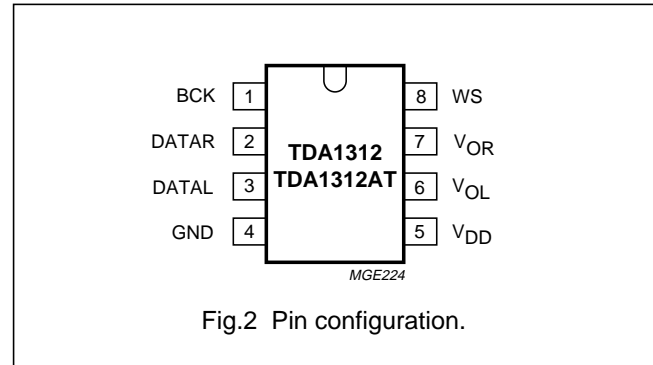

#### FUNCTIONAL DESCRIPTION

The basic operation of the continuous calibration DAC is illustrated in Fig.3. The figure shows the calibration and operation cycle. During calibration of the MOS current source (Fig.3a) transistor M1 is connected as a diode by applying a reference current. The voltage  $V_{gs}$  on the intrinsic gate-source capacitance  $C_{gs}$  of M1 is then determined by the transistor characteristics. After calibration of the drain current to the reference value  $I_{ref}$ , the switch S1 is opened and S2 is switched to the other position (Fig.3b). The gate-to-source voltage  $V_{gs}$  of M1 is not changed because the charge on  $C_{gs}$  is preserved. Therefore, the drain current of M1 will still be equal to  $I_{REF}$  and this exact duplicate of  $I_{REF}$  is now available at the OUT terminal.

The 32 current sources and the spare current source of the TDA1312A; AT are continuously calibrated (see Fig.1). The spare current source is included to allow continuous converter operation. The output of one calibrated source is

connected to an 11-bit binary current divider consisting of 2048 transistors. A symmetrical offset decoding principle is incorporated and arranges the bit switching in such a way that the zero-crossing is performed only by switching the LSB currents.

The TDA1312A; AT (CC-DAC) accepts serial input data formats of 16-bit word length. Left and right data words are time multiplexed. The most significant bit (bit 1) must always be first. The input data format is shown in Figs.4 and 5.

Data is placed in the right and left input registers (see Fig.1). The data in the input registers is simultaneously latched in the output registers which control the bit switches.

An internal offset voltage  $V_{OFF}$  is added to the full scale output voltage  $V_{FS}$ ;  $V_{OFF}$  and  $V_{FS}$  are proportional to  $V_{DD}$ :  
Where  $V_{DD1}/V_{DD2} = V_{FS1}/V_{FS2} = V_{OFF1}/V_{OFF2}$ .

Stereo continuous calibration  
DAC (CC-DAC)

TDA1312A; TDA1312AT

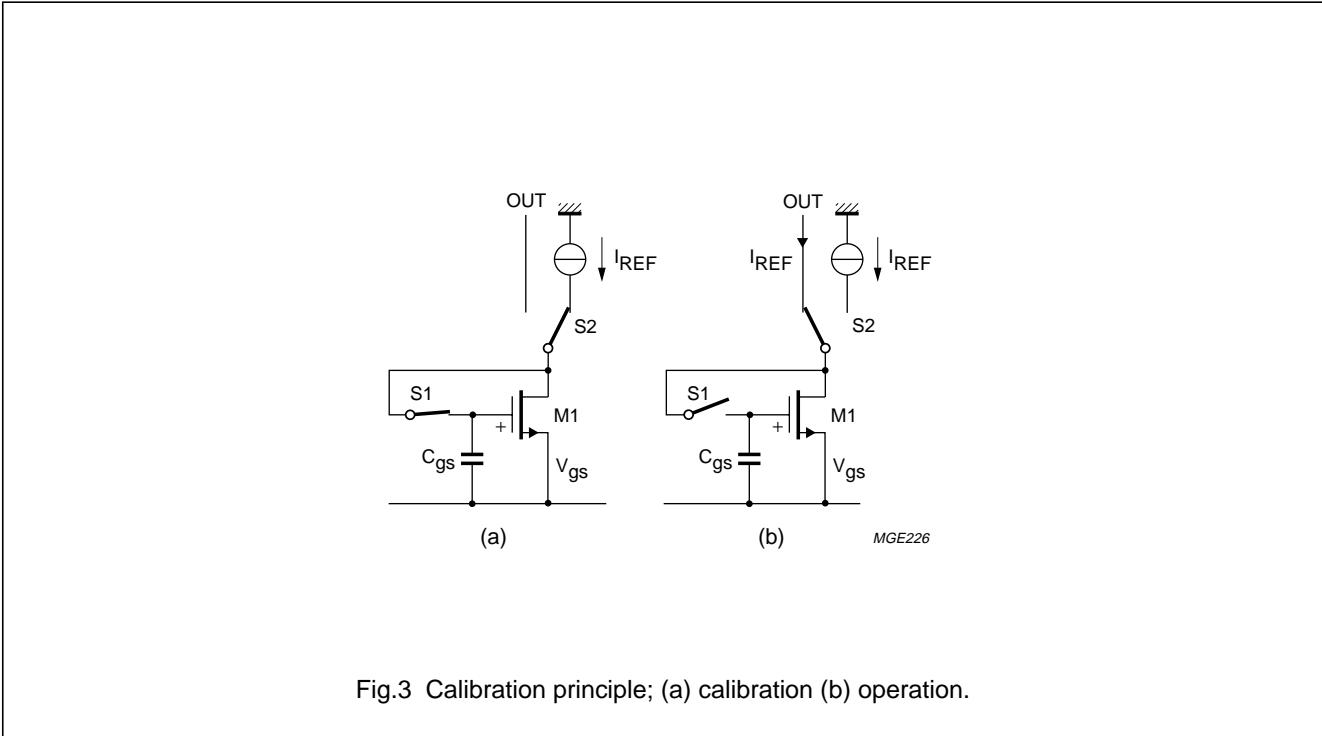

Fig.3 Calibration principle; (a) calibration (b) operation.

**LIMITING VALUES**

In accordance with the Absolute Maximum Rating System (IEC 134).

SYMBOL	PARAMETER	CONDITIONS	MIN.	MAX.	UNIT
V <sub>DD</sub>	supply voltage		-	6.0	V
T <sub>stg</sub>	storage temperature		-55	+150	°C
T <sub>XTAL</sub>	maximum crystal temperature		-	+150	°C
T <sub>amb</sub>	operating ambient temperature		-40	+85	°C
V <sub>es</sub>	electrostatic handling	note 1	-2000	+2000	V
		note 2	-200	+200	V

**Notes**

- Human body model: C = 100 pF; R = 1500 Ω; 3 zaps positive and negative.
- Machine model: C = 200 pF; L = 0.5 μH; R = 10 Ω; 3 zaps positive and negative.

**THERMAL RESISTANCE**

SYMBOL	PARAMETER	THERMAL RESISTANCE
R <sub>th j-a</sub>	from junction to ambient in free air	
	DIL8	100 K/W
	SO8	210 K/W

## Stereo continuous calibration DAC (CC-DAC)

TDA1312A; TDA1312AT

**CHARACTERISTICS** $V_{DD} = 5\text{ V}$ ;  $T_{amb} = 25\text{ °C}$ ; measured in Fig.1; unless otherwise specified.

SYMBOL	PARAMETER	CONDITIONS	MIN.	TYP.	MAX.	UNIT
<b>Supply</b>						
$V_{DD}$	positive supply voltage		4.0	5.0	5.5	V
$I_{DD}$	supply current	at code 0000H	–	3.4	6.0	mA
<b>Digital inputs; pins WS, BCK and DATA</b>						
$ I_{IL} $	input leakage current LOW	$V_I = 0\text{ V}$	–	–	10	$\mu\text{A}$
$ I_{IH} $	input leakage current HIGH	$V_I = 5\text{ V}$	–	–	10	$\mu\text{A}$
$f_{BCK}$	clock frequency		–	–	18.4	MHz
BR	bit rate data input		–	–	18.4	Mbits/s
$f_{WS}$	word select input frequency		–	–	384	kHz
<b>Timing (see Fig.4)</b>						
$t_r$	rise time		–	–	12	ns
$t_f$	fall time		–	–	12	ns
$t_{CY}$	bit clock cycle time		54	–	–	ns
$t_{BCKH}$	bit clock pulse width HIGH		15	–	–	ns
$t_{BCKL}$	bit clock pulse width LOW		15	–	–	ns
$t_{SU;DAT}$	data set-up time		12	–	–	ns
$t_{HD;DAT}$	data hold time to bit clock		2	–	–	ns
$t_{HD;WS}$	word select hold time		2	–	–	ns
$t_{SU;WS}$	word select set-up time		12	–	–	ns
<b>Analog outputs; pins <math>V_{OL}</math> and <math>V_{OR}</math></b>						
$V_{FS}$	full-scale voltage		1.8	2.0	2.2	V
$TC_{FS}$	full-scale temperature coefficient		–	$\pm 400$	–	ppm
$V_{OFF}$	offset voltage	at code 1000H	0.42	0.47	0.52	V
(THD+N)/S	total harmonic distortion plus noise	at 0 dB signal level; note 1	–	–68	–63	dB
			–	0.04	0.07	%
		at –60 dB signal level; note 1	–	–30	–24	dB
			–	3	6	%
		at –60 dB signal level; A-weighted; note1	–	–33	–	dB
	–	2	–	%		
	at 0 dB signal level; $f = 20\text{ Hz to }20\text{ kHz}$	–	–65	–61	dB	
		–	0.05	0.09	%	

Stereo continuous calibration  
DAC (CC-DAC)

TDA1312A; TDA1312AT

SYMBOL	PARAMETER	CONDITIONS	MIN.	TYP.	MAX.	UNIT
<b>Analog outputs; pins V<sub>OL</sub> and V<sub>OR</sub></b>						
t <sub>cs</sub>	current settling time to ±1 LSB		–	0.2	–	µs
α	channel separation		75	80	–	dB
δI <sub>O</sub>	unbalance between outputs	note 1	–	0.2	0.3	dB
t <sub>d</sub>	time delay between outputs		–	±0.2	–	µs
S/N	signal-to-noise ratio at bipolar zero	A-weighted; at code 0000H	86	92	–	dB

**Note**

1. Measured with 1 kHz sinewave generated at sampling rate of 192 kHz.

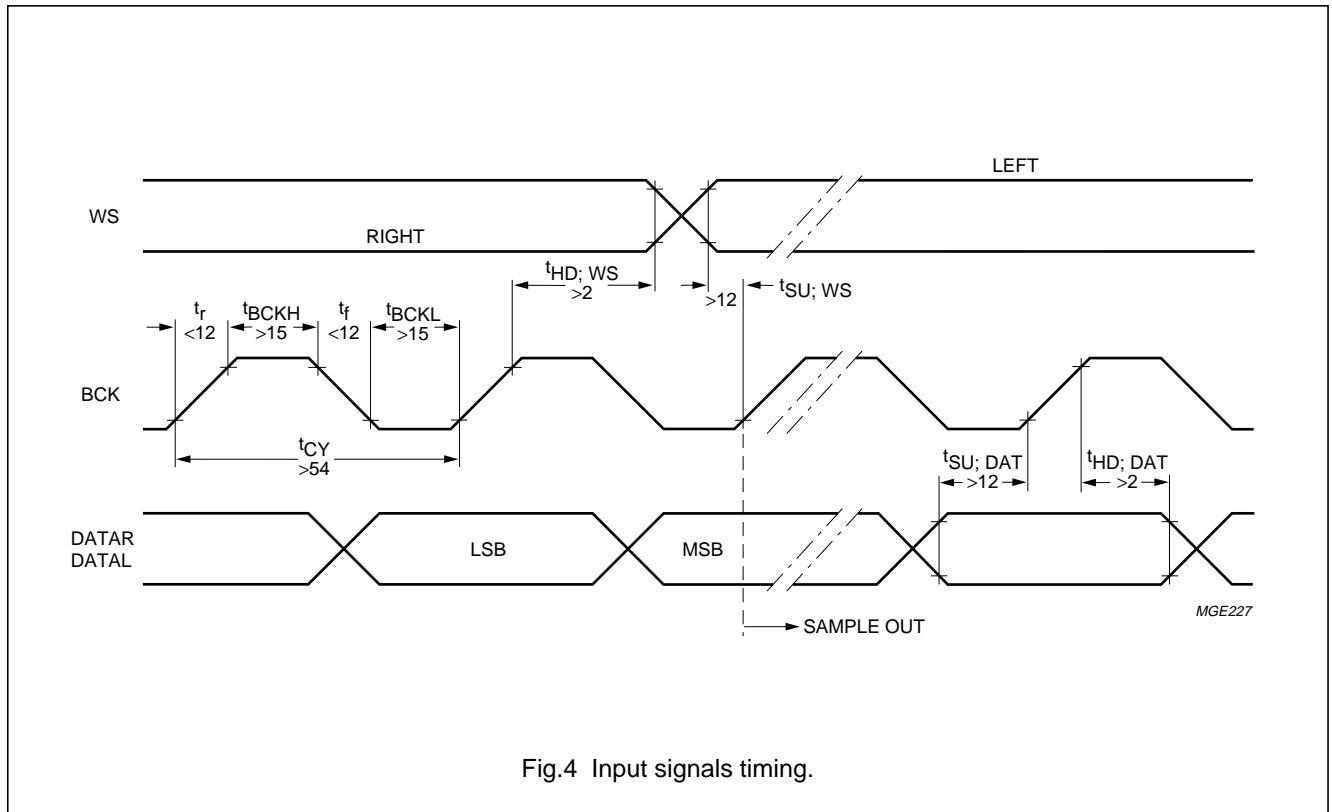

Fig.4 Input signals timing.



Stereo continuous calibration  
DAC (CC-DAC)

TDA1312A; TDA1312AT

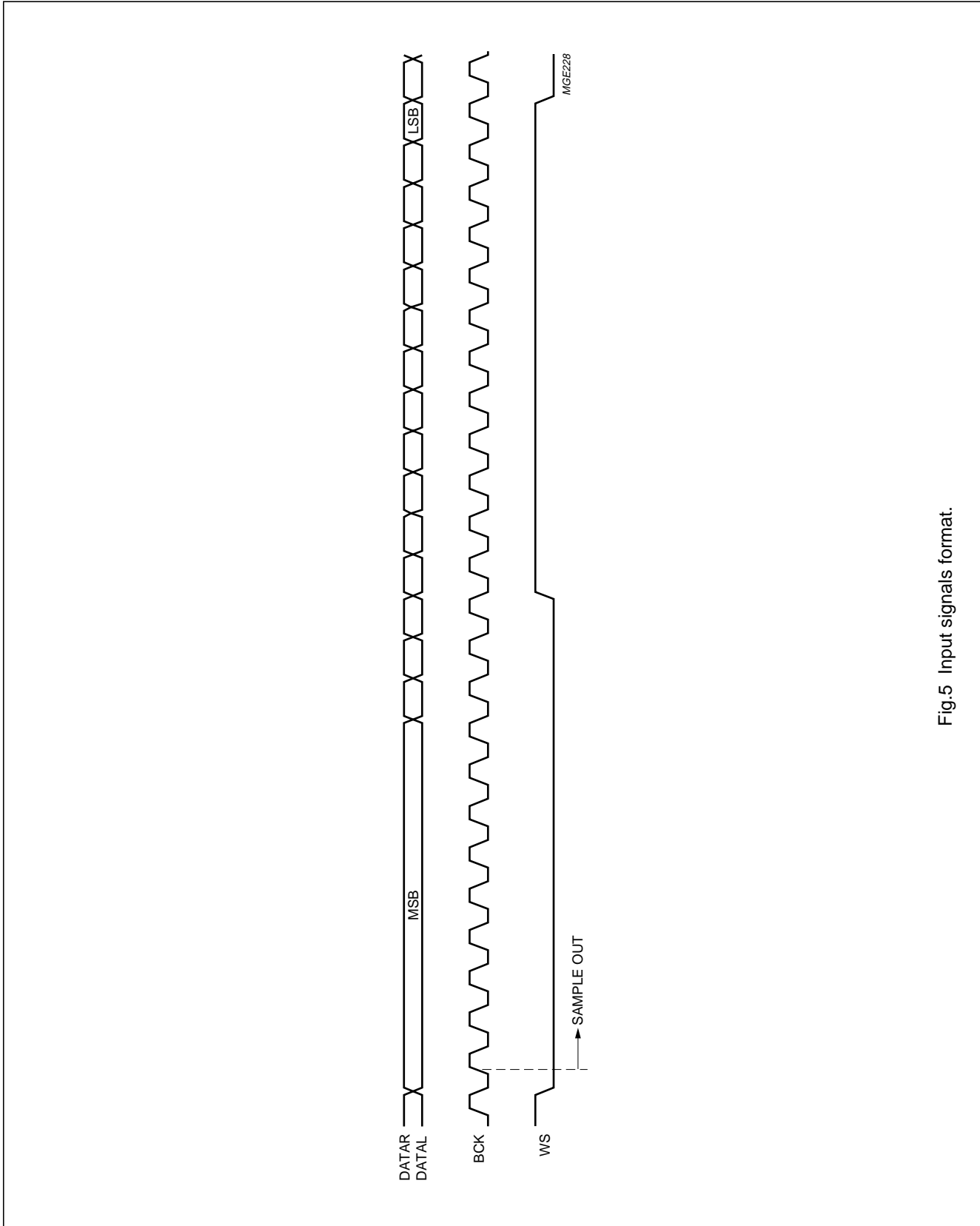

Fig.5 Input signals format.

Stereo continuous calibration  
DAC (CC-DAC)

TDA1312A; TDA1312AT

PACKAGE OUTLINES

DIP8: plastic dual in-line package; 8 leads (300 mil)

SOT97-1

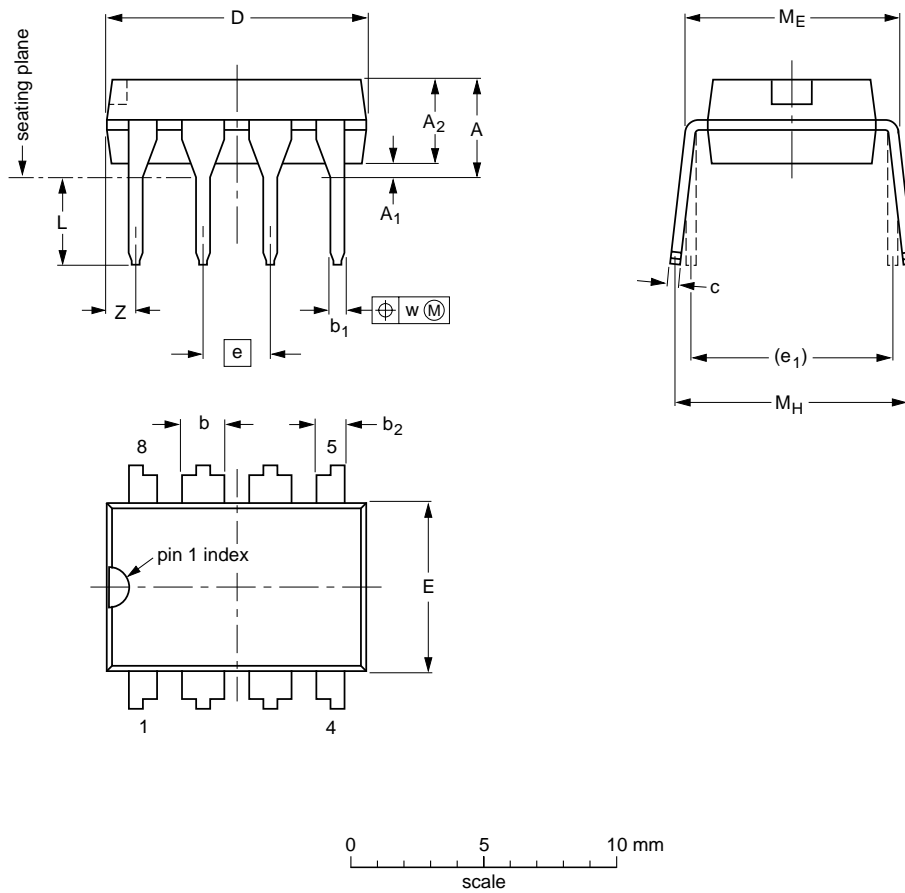

DIMENSIONS (inch dimensions are derived from the original mm dimensions)

UNIT	A max.	A <sub>1</sub> min.	A <sub>2</sub> max.	b	b <sub>1</sub>	b <sub>2</sub>	c	D <sup>(1)</sup>	E <sup>(1)</sup>	e	e <sub>1</sub>	L	M <sub>E</sub>	M <sub>H</sub>	w	Z <sup>(1)</sup> max.
mm	4.2	0.51	3.2	1.73 1.14	0.53 0.38	1.07 0.89	0.36 0.23	9.8 9.2	6.48 6.20	2.54	7.62	3.60 3.05	8.25 7.80	10.0 8.3	0.254	1.15
inches	0.17	0.020	0.13	0.068 0.045	0.021 0.015	0.042 0.035	0.014 0.009	0.39 0.36	0.26 0.24	0.10	0.30	0.14 0.12	0.32 0.31	0.39 0.33	0.01	0.045

Note

1. Plastic or metal protrusions of 0.25 mm maximum per side are not included.

OUTLINE VERSION	REFERENCES				EUROPEAN PROJECTION	ISSUE DATE
	IEC	JEDEC	EIAJ			
SOT97-1	050G01	MO-001AN				92-11-17 95-02-04

Stereo continuous calibration  
DAC (CC-DAC)

TDA1312A; TDA1312AT

SO8: plastic small outline package; 8 leads; body width 3.9 mm

SOT96-1

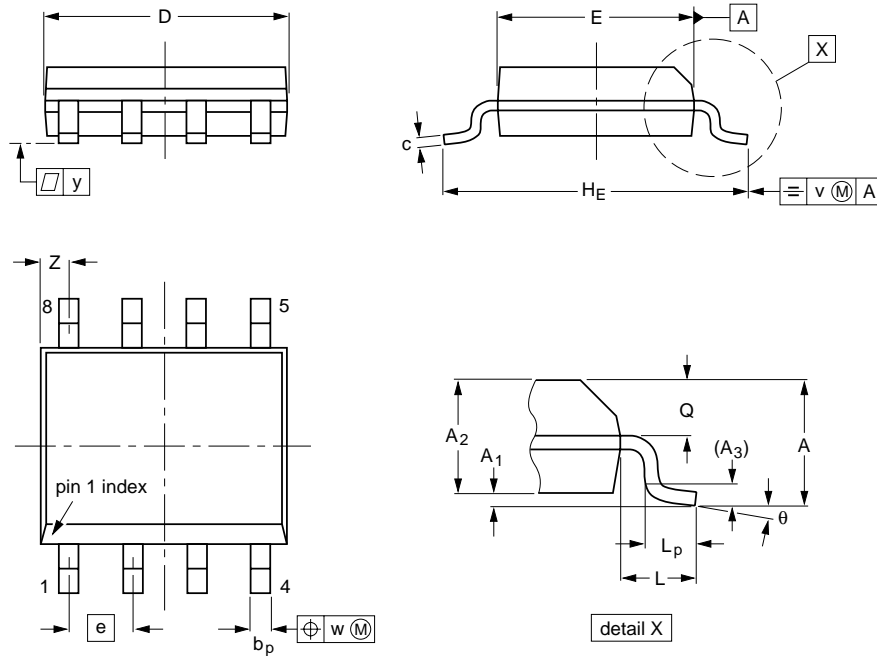

DIMENSIONS (inch dimensions are derived from the original mm dimensions)

UNIT	A max.	A <sub>1</sub>	A <sub>2</sub>	A <sub>3</sub>	b <sub>p</sub>	c	D <sup>(1)</sup>	E <sup>(2)</sup>	e	H <sub>E</sub>	L	L <sub>p</sub>	Q	v	w	y	z <sup>(1)</sup>	θ
mm	1.75	0.25 0.10	1.45 1.25	0.25	0.49 0.36	0.25 0.19	5.0 4.8	4.0 3.8	1.27	6.2 5.8	1.05	1.0 0.4	0.7 0.6	0.25	0.25	0.1	0.7 0.3	8° 0°
inches	0.069	0.010 0.004	0.057 0.049	0.01	0.019 0.014	0.0100 0.0075	0.20 0.19	0.16 0.15	0.050	0.244 0.228	0.041	0.039 0.016	0.028 0.024	0.01	0.01	0.004	0.028 0.012	

Notes

1. Plastic or metal protrusions of 0.15 mm maximum per side are not included.
2. Plastic or metal protrusions of 0.25 mm maximum per side are not included.

OUTLINE VERSION	REFERENCES				EUROPEAN PROJECTION	ISSUE DATE
	IEC	JEDEC	EIAJ			
SOT96-1	076E03S	MS-012AA				95-02-04 97-05-22

## Stereo continuous calibration DAC (CC-DAC)

## TDA1312A; TDA1312AT

### SOLDERING

#### Introduction

There is no soldering method that is ideal for all IC packages. Wave soldering is often preferred when through-hole and surface mounted components are mixed on one printed-circuit board. However, wave soldering is not always suitable for surface mounted ICs, or for printed-circuits with high population densities. In these situations reflow soldering is often used.

This text gives a very brief insight to a complex technology. A more in-depth account of soldering ICs can be found in our *"IC Package Databook"* (order code 9398 652 90011).

#### DIP

##### SOLDERING BY DIPPING OR BY WAVE

The maximum permissible temperature of the solder is 260 °C; solder at this temperature must not be in contact with the joint for more than 5 seconds. The total contact time of successive solder waves must not exceed 5 seconds.

The device may be mounted up to the seating plane, but the temperature of the plastic body must not exceed the specified maximum storage temperature ( $T_{stg\ max}$ ). If the printed-circuit board has been pre-heated, forced cooling may be necessary immediately after soldering to keep the temperature within the permissible limit.

##### REPAIRING SOLDERED JOINTS

Apply a low voltage soldering iron (less than 24 V) to the lead(s) of the package, below the seating plane or not more than 2 mm above it. If the temperature of the soldering iron bit is less than 300 °C it may remain in contact for up to 10 seconds. If the bit temperature is between 300 and 400 °C, contact may be up to 5 seconds.

#### SO

##### REFLOW SOLDERING

Reflow soldering techniques are suitable for all SO packages.

Reflow soldering requires solder paste (a suspension of fine solder particles, flux and binding agent) to be applied to the printed-circuit board by screen printing, stencilling or pressure-syringe dispensing before package placement.

Several techniques exist for reflowing; for example, thermal conduction by heated belt. Dwell times vary between 50 and 300 seconds depending on heating method. Typical reflow temperatures range from 215 to 250 °C.

Preheating is necessary to dry the paste and evaporate the binding agent. Preheating duration: 45 minutes at 45 °C.

##### WAVE SOLDERING

Wave soldering techniques can be used for all SO packages if the following conditions are observed:

- A double-wave (a turbulent wave with high upward pressure followed by a smooth laminar wave) soldering technique should be used.
- The longitudinal axis of the package footprint must be parallel to the solder flow.
- The package footprint must incorporate solder thieves at the downstream end.

During placement and before soldering, the package must be fixed with a droplet of adhesive. The adhesive can be applied by screen printing, pin transfer or syringe dispensing. The package can be soldered after the adhesive is cured.

Maximum permissible solder temperature is 260 °C, and maximum duration of package immersion in solder is 10 seconds, if cooled to less than 150 °C within 6 seconds. Typical dwell time is 4 seconds at 250 °C.

A mildly-activated flux will eliminate the need for removal of corrosive residues in most applications.

##### REPAIRING SOLDERED JOINTS

Fix the component by first soldering two diagonally-opposite end leads. Use only a low voltage soldering iron (less than 24 V) applied to the flat part of the lead. Contact time must be limited to 10 seconds at up to 300 °C. When using a dedicated tool, all other leads can be soldered in one operation within 2 to 5 seconds between 270 and 320 °C.

## Stereo continuous calibration DAC (CC-DAC)

TDA1312A; TDA1312AT

### DEFINITIONS

<b>Data sheet status</b>	
Objective specification	This data sheet contains target or goal specifications for product development.
Preliminary specification	This data sheet contains preliminary data; supplementary data may be published later.
Product specification	This data sheet contains final product specifications.
<b>Limiting values</b>	
Limiting values given are in accordance with the Absolute Maximum Rating System (IEC 134). Stress above one or more of the limiting values may cause permanent damage to the device. These are stress ratings only and operation of the device at these or at any other conditions above those given in the Characteristics sections of the specification is not implied. Exposure to limiting values for extended periods may affect device reliability.	
<b>Application information</b>	
Where application information is given, it is advisory and does not form part of the specification.	

### LIFE SUPPORT APPLICATIONS

These products are not designed for use in life support appliances, devices, or systems where malfunction of these products can reasonably be expected to result in personal injury. Philips customers using or selling these products for use in such applications do so at their own risk and agree to fully indemnify Philips for any damages resulting from such improper use or sale.