

VI TELEFILTER **Filter specification** **TFS 380A** **1/5**

Measurement Condition

Ambient Temperature: 23 °C
 Input Power Level: 0 dBm
 Source impedance: 50 Ω
 Load impedance: 50 Ω
 Terminating impedances:
 input: 720 Ω || -4.7pF
 output: 1000 Ω || -4.1pF

Characteristics

Remark:

Reference level for the relative attenuation a_{rel} is the minimum pass band attenuation a_{min} . It is defined as the insertion loss a_e . The nominal frequency f_N is fixed to 380,0 MHz. The center frequency f_C is the arithmetic mean value of the upper and lower frequencies at the 1 dB filter attenuation level relative to the insertion loss a_e . The given values for the insertion loss, the relative attenuation a_{rel} and the group delay ripple have to be reached at the frequencies given below also if the centre frequency f_C is shifted due to the temperature coefficient of frequency TC_f in the operating temperature range and due to a production tolerance for the centre frequency f_C .

D a t a		typ. Value	Limit
Insertion Loss (Reference level)	$a_e = a_{min}$	14,0 dB	max. 17 dB
Nominal Frequency	f_N	-	380,0 MHz
1 dB - Bandwidth	BW	4,2 MHz	min. 4,05 MHz
Relative Attenuation	a_{rel}		
$f_N \pm 2,5$ MHz ... $f_N \pm 3,0$ MHz		5 dB	min. 3 dB
$f_N \pm 3,0$ MHz ... $f_N \pm 3,25$ MHz		20 dB	min. 10 dB
$f_N \pm 3,25$ MHz ... $f_N \pm 3,5$ MHz		35 dB	min. 20 dB
$f_N \pm 3,5$ MHz ... $f_N \pm 5,0$ MHz		38 dB	min. 30 dB
$f_N \pm 5,0$ MHz ... $f_N \pm 100,0$ MHz		50 dB	min. 40 dB
Pass Band Ripple $f_N \pm 2,025$ MHz		0,4 dB	max. 1 dB
Group delay ripple $f_N \pm 2,025$ MHz	φ	65 ns	max. 100 ns
Operating Temperature Range			- 0 °C ... + 70 °C

Generated: _____

Checked / approved: _____

VI TELEFILTER
 Potsdamer Straße 18
 D 14 513 TELTOW / Germany
 Tel: (+49) 3328 4784-0 / Fax: (+49) 3328 4784-30
 E-Mail: tft@telefilter.com

Vectron International, Inc.
 267 Lowell Road
 Hudson, NH 03051 / USA
 Tel: (603) 598-0070 Fax: (603) 598-0075
 E-Mail: vti@vtinh.com

VI TELEFILTER reserves the right to make changes to the product(s) and/or information contained herein without notice. No liability is assumed as a result of their use or application. No rights under any patent accompany the sale of any such product(s) or information.



VI TELEFILTER

Filter specification

TFS 380A

2/5

Construction and pin connection

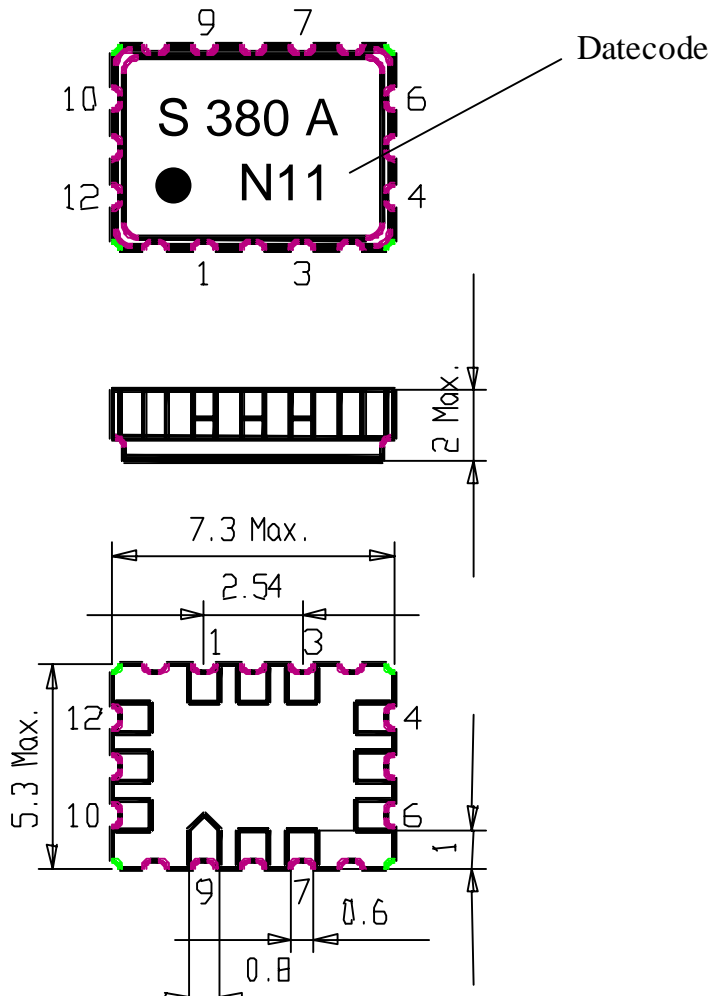

- | | |
|----|------------------|
| 1 | Ground |
| 2 | Ground |
| 3 | Output RF Return |
| 4 | Output |
| 5 | Ground |
| 6 | Ground |
| 7 | Ground |
| 8 | Ground |
| 9 | Input RF Return |
| 10 | Input |
| 11 | Ground |
| 12 | Ground |

Datecode: Year+week
 L 1999
 M 2000
 N 2001
 ...

50 Ω test circuit

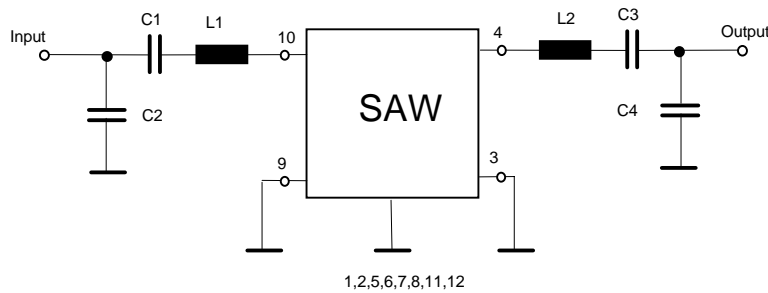

VI TELEFILTER
 Potsdamer Straße 18
 D 14 513 TELTOW / Germany
 Tel: (+49) 3328 4784-0 / Fax: (+49) 3328 4784-30
 E-Mail: tft@telefilter.com

Vectron International, Inc.
 267 Lowell Road
 Hudson, NH 03051 / USA
 Tel: (603) 598-0070 Fax: (603) 598-0075
 E-Mail: vti@vtinh.com

VI TELEFILTER**Filter specification****TFS 380A****3/5****Stability Characteristics:**

After the following tests the filter shall meet the whole specification:

1. Shock: 500g, 18 ms, half sine wave, 3 shocks each plane;
DIN IEC 68 T2 - 27
2. Vibration: 10 Hz to 500 Hz, 0,35 mm or 5g respectively, 1 octave per min, 10 cycles per plan, 3 plans;
DIN IEC 68 T2 - 6
3. Damp heat: 25 °C to 55°C / 95% r.H. / 10 cycles
(cycle) DIN IEC 68 - 2 – 30 Db
4. Resistance to solder heat (reflow): max. 2 times reflow process;
for temperature conditions refer to the attached "Air reflow temperature conditions" on page 4;

Packing:

Tape & Reel: IEC 286 - 3, with exception of value for N and minimum bending radius;
tape type II, embossed carrier tape with top cover tape on the upper side;

max. pieces of filters per reel: 3000
Reel of empty components at start: min 300 mm
Reel of empty components at start including leader: min 500 mm
Trailer min 300 mm

Tape (all dimensions in mm)

W	: 16 ± 0,3
Po	: 4 ± 0,1
Do	: 1,5 + 0,5
E	: 1,75 ± 0,1
F	: 7,5 ± 0,1
G (min)	: 0,6
P2	: 2 ± 0,1
P1	: 8 ± 0,1
D1(min)	: 1,5
Ao	: 5,5 ± 0,1
Bo	: 7,5 ± 0,1
Ct	: 13,5+/-0,1

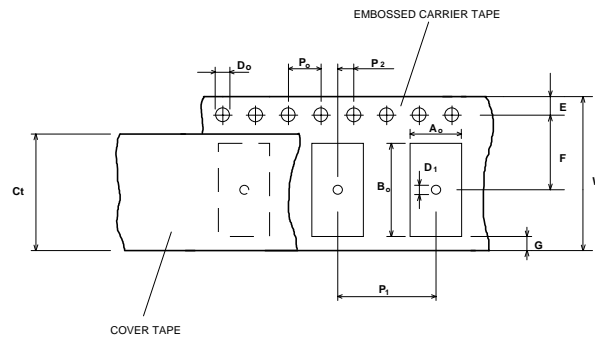
**Reel (all dimensions in mm):**

A	:	330
W1	:	16,4 +2
W2 (max)	:	22,4
N (min)	:	50
C	:	13 + 0,5
	:	- 0,2

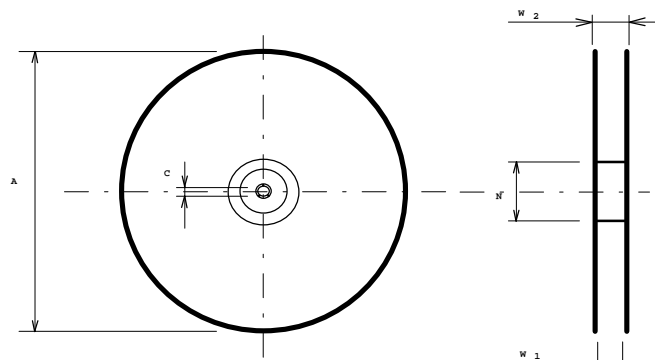

The minimum bending radius is 45 mm. The mounting surface of the filters faces the bottom side of the embossed carrier tape. The marking of the filters is readable if the sprocket holes are on the left side of the tape, i.e. pin 1 identifier is close to the sprocket holes.

VI TELEFILTER
Potsdamer Straße 18
D 14 513 TELTOW / Germany
Tel: (+49) 3328 4784-0 / Fax: (+49) 3328 4784-30
E-Mail: tft@telefilter.com

Vectron International, Inc.
267 Lowell Road
Hudson, NH 03051 / USA
Tel: (603) 598-0070 Fax: (603) 598-0075
E-Mail: vti@vtinh.com

VI TELEFILTER**Filter specification****TFS 380A****4/5****Air reflow temperature conditions**

1st and 2nd air reflow profile

Name:	pre-heating periods	main-heating periods	peak temperature
Temperature:	150 °C - 170 °C	over 200 °C	255 °C ± 5 °C
Time:	60 sec. - 90 sec.	20 sec. - 25 sec.	

Air reflow profile

Table for temperature vs. time during the air reflow process

Tolerance of temperatures: ± 5 °C

time / sec.	temperature / °C	time / sec.	temperature / °C
0	23	140	160
10	34	150	161
20	46	160	164
30	60	170	170
40	80	180	180
50	103	190	205
60	121	195	230
70	134	200	255
80	143	205	230
90	150	210	205
100	154	215	180
110	156	220	165
120	158	230	140
130	159	240	120

VI TELEFILTER
 Potsdamer Straße 18
 D 14 513 TELTOW / Germany
 Tel: (+49) 3328 4784-0 / Fax: (+49) 3328 4784-30
 E-Mail: tft@telefilter.com

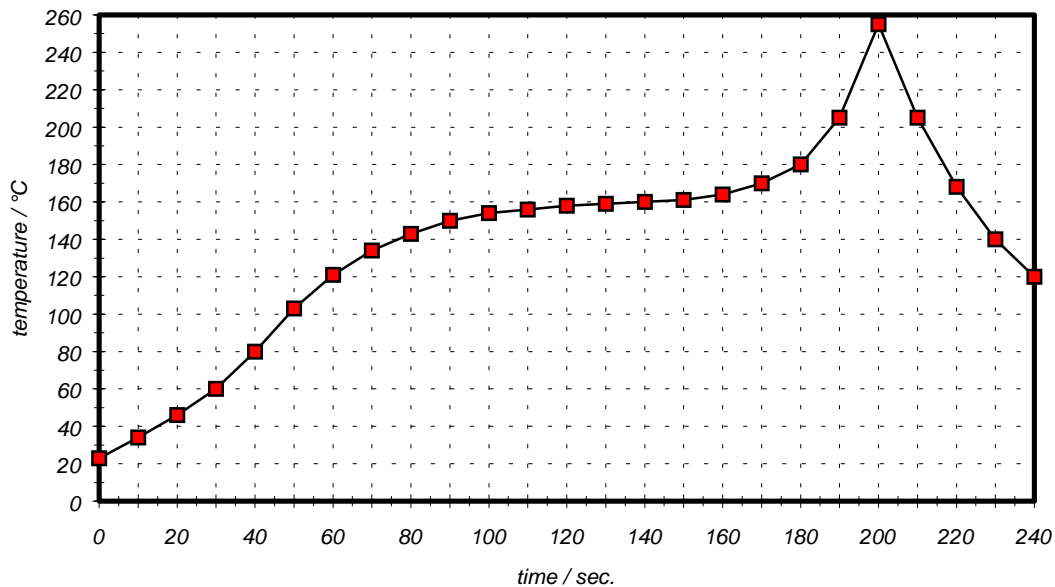
Vectron International, Inc.
 267 Lowell Road
 Hudson, NH 03051 / USA
 Tel: (603) 598-0070 Fax: (603) 598-0075
 E-Mail: vti@vtinh.com

VI TELEFILTER**Filter specification****TFS 380A****5/5**

History

Version	Reason of Changes	Name	Date
Development specification			
1.0	new generation	Steiner	11.04.2000
2.0	- correction of attenuation specification according to customer needs - stability characteristics, tape and reel dimensions, air reflow profile added	Steiner	04.08.2000
Filter specification			
3.0	- terminating impedances added - loss definition corrected - typical values added	Steiner	13.03.2001

VI TELEFILTER
Potsdamer Straße 18
D 14 513 TELTOW / Germany
Tel: (+49) 3328 4784-0 / Fax: (+49) 3328 4784-30
E-Mail: tft@telefilter.com

Vectron International, Inc.
267 Lowell Road
Hudson, NH 03051 / USA
Tel: (603) 598-0070 Fax: (603) 598-0075
E-Mail: vti@vtinh.com