

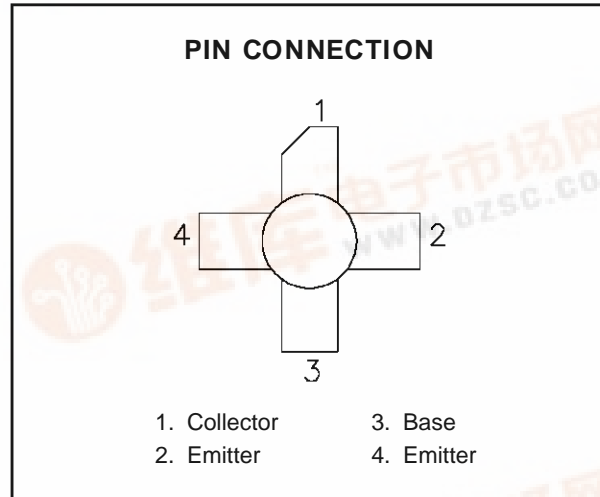

SD1733 (TH513)

RF & MICROWAVE TRANSISTORS HF SSB APPLICATIONS

- OPTIMIZED FOR SSB
- 30 MHz
- 50 VOLTS
- COMMON EMITTER
- GOLD METALLIZATION
- P_{OUT} = 75 W MIN. WITH 14.0 dB GAIN

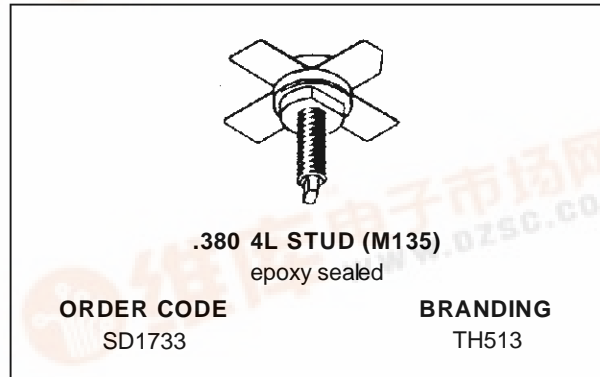

DESCRIPTION

The SD1733 is a 50 V Class AB epitaxial silicon NPN planar transistor designed primarily for SSB and VHF communications. This device utilizes emitter ballasting for improved ruggedness and reliability.

ABSOLUTE MAXIMUM RATINGS (T_{case} = 25°C)

Symbol	Parameter	Value	Unit
V _{CBO}	Collector-Base Voltage	110	V
V _{CEO}	Collector-Emitter Voltage	55	V
V _{EBO}	Emitter-Base Voltage	4.0	V
I _C	Device Current	3.25	A
P _{DISS}	Power Dissipation	127	W
T _J	Junction Temperature	+200	°C
T _{STG}	Storage Temperature	- 65 to +150	°C

THERMAL DATA

R _{TH(j-c)}	Junction-Case Thermal Resistance	2.0	°C/W
----------------------	----------------------------------	-----	------



SD1733 (TH513)

ELECTRICAL SPECIFICATIONS ($T_{\text{case}} = 25^{\circ}\text{C}$)

STATIC

Symbol	Test Conditions		Value			Unit
			Min.	Typ.	Max.	
BV_{CES}	$I_{\text{C}} = 100\text{mA}$	$V_{\text{BE}} = 0\text{V}$	110	—	—	V
BV_{CEO}	$I_{\text{C}} = 200\text{mA}$	$I_{\text{B}} = 0\text{mA}$	55	—	—	V
BV_{EBO}	$I_{\text{E}} = 10\text{mA}$	$I_{\text{C}} = 0\text{mA}$	4.0	—	—	V
h_{FE}	$V_{\text{CE}} = 6\text{V}$	$I_{\text{C}} = 1.4\text{A}$	19	—	50	—

DYNAMIC

Symbol	Test Conditions		Value			Unit
			Min.	Typ.	Max.	
P_{OUT}	$f = 30\text{ MHz}$	$V_{\text{CE}} = 50\text{ V}$	75	—	—	W
G_{P}^*	$P_{\text{OUT}} = 75\text{ W PEP}$	$V_{\text{CE}} = 50\text{ V}$	14	—	—	dB
IMD^*	$P_{\text{OUT}} = 75\text{ W PEP}$	$V_{\text{CE}} = 50\text{ V}$	—	—	-30	dBc
η_{C}^*	$P_{\text{OUT}} = 75\text{ W PEP}$	$V_{\text{CE}} = 50\text{ V}$	37	—	—	%
C_{OB}	$f = 1\text{ MHz}$	$V_{\text{CB}} = 50\text{ V}$	—	—	100	pF

Note: * $f_1 = 30.00\text{ MHz}$, $f_2 = 30.001\text{ MHz}$

TEST CIRCUIT

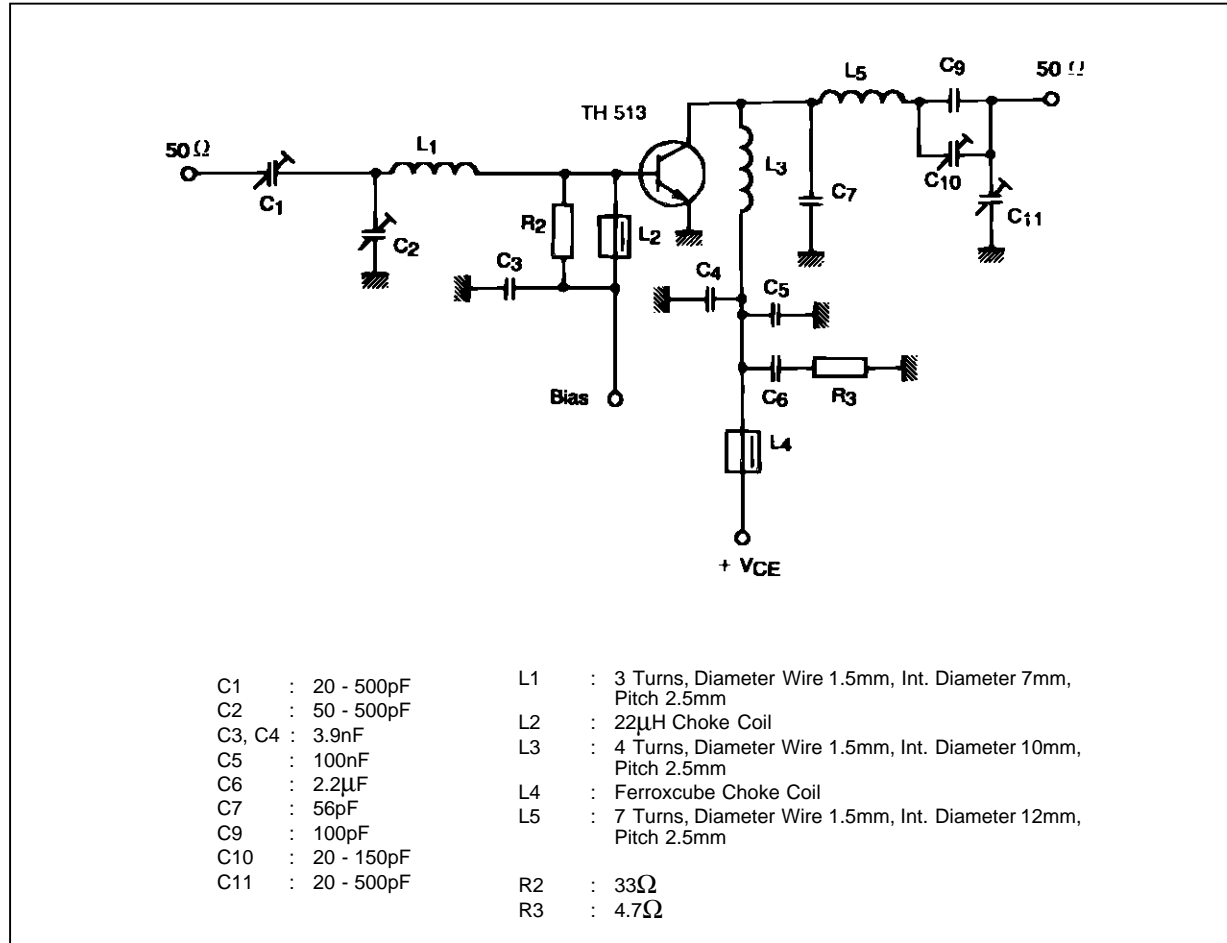

BIAS CIRCUIT

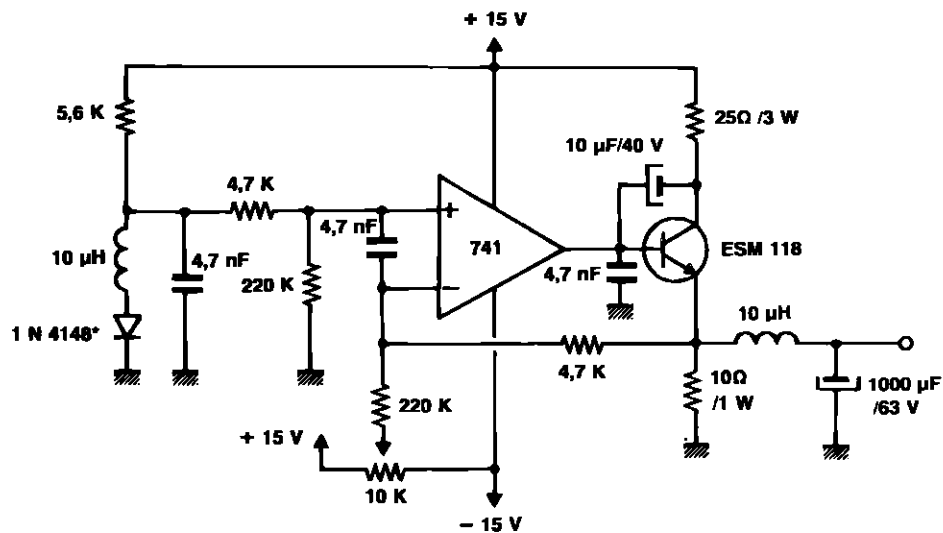

SD1733 (TH513)

PACKAGE MECHANICAL DATA

Ref.: Dwg. No.12-0135

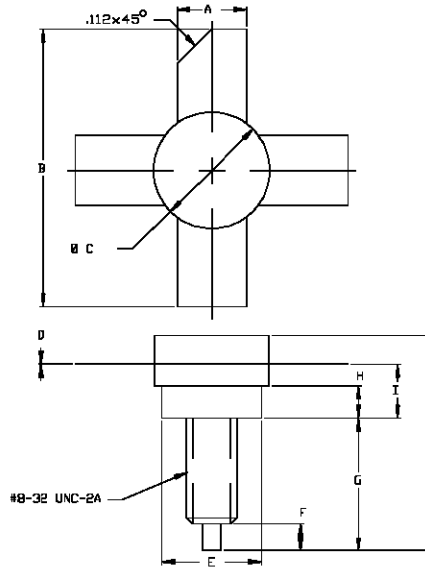

SGS-THOMSON MICROELECTRONICS		
	MINIMUM Inches/mm	MAXIMUM Inches/mm
A	.220/5,59	.230/5,84
B	.980/24,89	
C	.370/9,40	.385/9,78
D	.004/0,10	.007/0,18
E	.320/8,13	.330/8,38
F	.100/2,54	.130/3,30
G	.450/11,43	.490/12,45
H	.090/2,29	.100/2,54
I	.155/3,94	.175/4,45
J		.750/19,05

Information furnished is believed to be accurate and reliable. However, SGS-THOMSON Microelectronics assumes no responsibility for the consequences of use of such information nor for any infringement of patents or other rights of third parties which may result from its use. No license is granted by implication or otherwise under any patent or patent rights of SGS-THOMSON Microelectronics. Specifications mentioned in this publication are subject to change without notice. This publication supersedes and replaces all information previously supplied. SGS-THOMSON Microelectronics products are not authorized for use as critical components in life support devices or systems without express written approval of SGS-THOMSON Microelectronics.

© 1994 SGS-THOMSON Microelectronics - All Rights Reserved

SGS-THOMSON Microelectronics GROUP OF COMPANIES
 Australia - Brazil - France - Germany - Hong Kong - Italy - Japan - Korea - Malaysia - Malta - Morocco - The Netherlands -
 Singapore - Spain - Sweden - Switzerland - Taiwan - Thailand - United Kingdom - U.S.A