



TH71102

315/433MHz FSK/FM/ASK Receiver

Features

- Double superhet architecture for high degree of image rejection
- FSK for digital data and FM reception for analog signal transmission
- FM/FSK demodulation with phase-coincidence demodulator
- Low current consumption in active mode and very low standby current
- Switchable LNA gain for improved dynamic range
- RSSI allows signal strength indication and ASK detection
- Surface mount package LQFP32

Ordering Information

Part No.	Temperature Range	Package
TH71102	-40 °C to 85°C	LQFP32

Application Examples

- General digital and analog 315 MHz or 433 MHz ISM band usage
- Low-power telemetry
- Alarm and security systems
- Keyless car and central locking
- Pagers

Technical Data Overview

- Input frequency range: 300 MHz to 450 MHz
- Power supply range: 2.5 V to 5.5 V
- Temperature range: -40 °C to +85 °C
- Operating current: 6.5 mA at low gain and 8.2 mA at high gain mode
- Standby current: < 100 nA
- Sensitivity: -111 dBm¹⁾ with 40 kHz second IF filter BW (incl. SAW front-end filter loss)
- Sensitivity: -104 dBm²⁾ with 150 kHz second IF filter BW (incl. SAW front-end filter loss)
- Range of first IF: 10 MHz to 80 MHz
- Range of second IF: 455 kHz to 21.4 MHz
- Maximum input level: -10 dBm at ASK and 0 dBm at FSK
- Image rejection: > 65 dB (e.g. with SAW front-end filter and at 10.7 MHz 2nd IF)
- Spurious emission: < -70 dBm
- Input frequency acceptance: ±50 kHz (with AFC option)
- RSSI range: 70 dB
- Frequency deviation range: ±5 kHz to ±120 kHz
- Maximum data rate: 80 kbit/s NRZ
- Maximum analog modulation frequency: 15 kHz

¹⁾ at ± 8 kHz FSK deviation, BER = 3·10⁻³ and phase-coincidence demodulation

²⁾ at ± 50 kHz FSK deviation, BER = 3·10⁻³ and phase-coincidence demodulation



General Description

The TH71102 receiver IC consists of the following building blocks:

- PLL synthesizer (PLL SYNTH) for generation of the first and second local oscillator signals LO1 and LO2
- Parts of the PLL SYNTH are the high-frequency VCO1, the feedback dividers DIV_8 and DIV_2, a phase-frequency detector (PFD) with charge pump (CP) and a crystal-based reference oscillator (RO)
- Low-noise amplifier (LNA) for high-sensitivity RF signal reception
- First mixer (MIX1) for down-conversion of the RF signal to the first IF (IF1)
- second mixer (MIX2) for down-conversion of the IF1 to the second IF (IF2)
- IF amplifier (IFA) to amplify and limit the IF2 signal and for RSSI generation
- Phase coincidence demodulator (DEMODO) with third mixer (MIX3) to demodulate the IF signal
- Operational amplifier (OA) for data slicing, filtering and ASK detection
- Bias circuitry for bandgap biasing and circuit shutdown

With the TH71102 receiver chip, various circuit configurations can be arranged in order to meet a number of different customer requirements. For FM/FSK reception the IF tank used in the phase coincidence demodulator can be constituted either by a ceramic resonator or an LC tank (optionally with a varactor diode to create an AFC circuit). In ASK configuration, the RSSI signal is feed to an ASK detector, which is constituted by the operational amplifier.

Demodulation	Type of receiver
FM / FSK	narrow-band RX with ceramic demodulation tank
FM / FSK	wide-band RX with LC demodulation tank
ASK	RX with RSSI-based demodulation

The superheterodyne configuration is double conversion where MIX1 and MIX2 are driven by the internal local oscillator signals LO1 and LO2, respectively. This allows a high degree of image rejection, achieved in conjunction with an RF frontend filter. Efficient RF frontend filtering is realized by using a SAW, ceramic or helix filter in front of the LNA and by adding an LC filter at the LNA output.

A single-conversion variant, called TH71101, is also available. Both RXICs have the same die. At the TH71101 the second mixer MIX2 operates as an amplifier.

Block Diagram

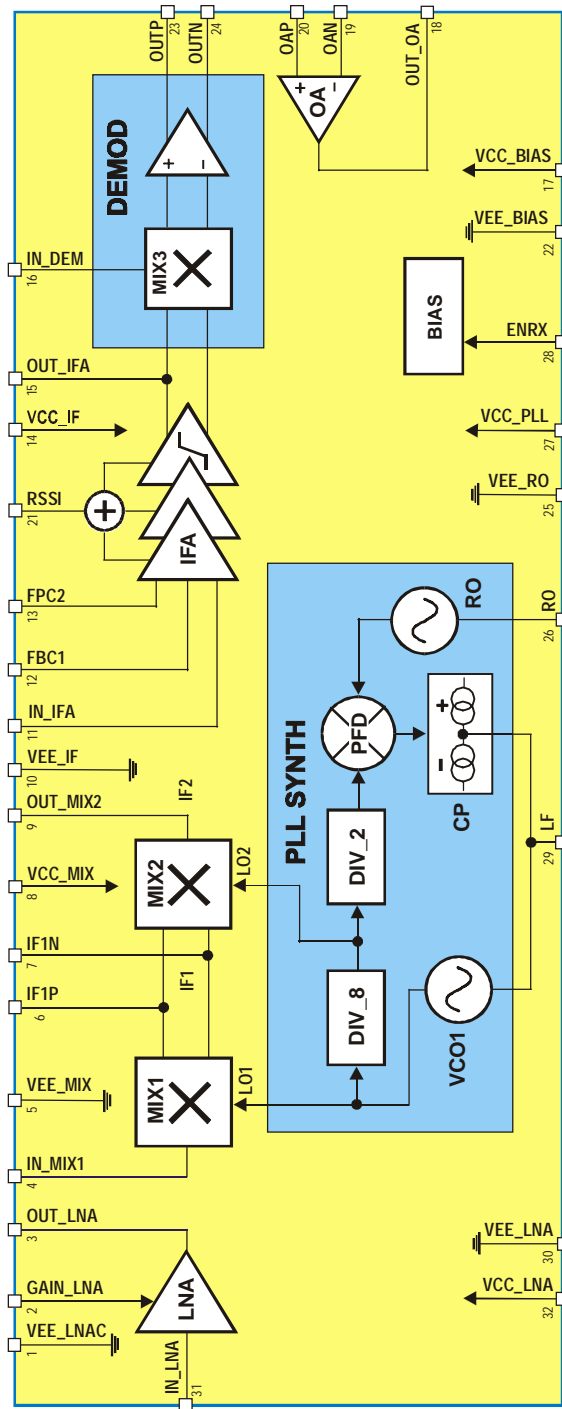

Fig. 1: TH71102 block diagram

Frequency Planning

Frequency planning is straightforward for single-conversion applications because there is only one IF that might be chosen, and then the only possible choice is low-side or high-side injection of the LO1 signal (which is now the one and only LO signal in the receiver).

The receiver's double-conversion architecture requires careful frequency planning. Besides the desired RF input signal, there are a number of spurious signals that may cause an undesired response at the output. Among them are the image of the RF signal (that must be suppressed by the RF front-end filter), spurious signals injected to the first IF (IF1) and their images which could be mixed down to the same second IF (IF2) as the desired RF signal (they must be suppressed by the LC filter at IF1 and/or by low-crosstalk design).

By configuring the TH71102 for double conversion and using its internal PLL synthesizer with fixed feedback divider ratios of $N1 = 8$ (DIV_8) and $N2 = 2$ (DIV_2), four types of down-conversion are possible: low-side injection of LO1 and LO2 (**low-low**), LO1 low-side and LO2 high-side (**low-high**), LO1 high-side and LO2 low-side (**high-low**) or LO1 and LO2 high-side (**high-high**). The following table summarizes some equations that are useful to calculate the crystal reference frequency (REF), the first IF (IF1) and the VCO1 or first LO frequency (LO1), respectively, for a given RF and second IF (IF2).

Injection type	high-high	low-low	high-low	low-high
REF	$(RF - IF2)/14$	$(RF - IF2)/18$	$(RF + IF2)/14$	$(RF + IF2)/18$
LO1	$16 \bullet REF$	$16 \bullet REF$	$16 \bullet REF$	$16 \bullet REF$
IF1	$LO1 - RF$	$RF - LO1$	$LO1 - RF$	$RF - LO1$
LO2	$2 \bullet REF$	$2 \bullet REF$	$2 \bullet REF$	$2 \bullet REF$
IF2	$LO2 - IF1$	$IF1 - LO2$	$IF1 - LO2$	$LO2 - IF1$

The following table depicts generated, desired, possible images and some undesired signals considering the examples of 315 MHz and 433.6 MHz RF reception at $IF2 = 10.7$ MHz.

Signal type	RF = 315 MHz	RF = 315 MHz	RF = 315 MHz	RF = 315 MHz	RF = 433.6 MHz	RF = 433.6 MHz	RF = 433.6 MHz	RF = 433.6 MHz
Injection type	high-high	low-low	high-low	low-high	high-high	low-low	high-low	low-high
REF / MHz	21.73571	16.90556	23.26429	18.09444	30.20714	23.49444	31.73571	24.68333
LO1 / MHz	347.77143	270.48889	372.22857	289.51111	483.31429	375.91111	507.77143	394.93333
IF1 / MHz	32.77143	44.51111	57.22857	25.48889	49.71429	57.68889	74.17143	38.66667
LO2 / MHz	43.47143	33.81111	46.52857	36.18889	60.41429	46.98889	63.47143	49.36667
RF image/MHz	380.54286	225.97778	429.45714	264.02222	533.02857	318.22222	581.94286	356.26667
IF1 image/MHz	54.17143	23.11111	35.82857	46.88889	71.11429	36.28889	52.77143	60.06667

The selection of the reference crystal frequency is based on some assumptions. As for example: the first IF and the image frequencies should not be in a radio band where strong interfering signals might occur (because they could represent parasitic receiving signals), the LO1 signal should be in the range of 300 MHz to 430 MHz (because this is the optimum frequency range of the VCO1). Furthermore the first IF should be as high as possible to achieve highest RF image rejection. The columns in bold depict the selected frequency plans to receive at 315 MHz and 433.6 MHz, respectively.

Pin Definition and Description

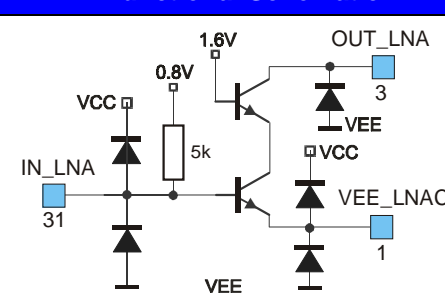
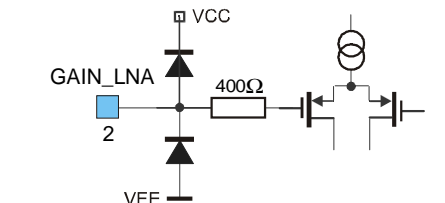
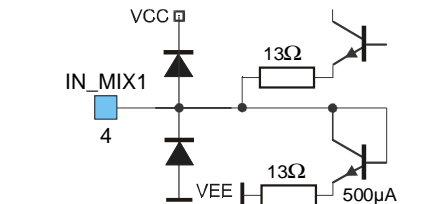
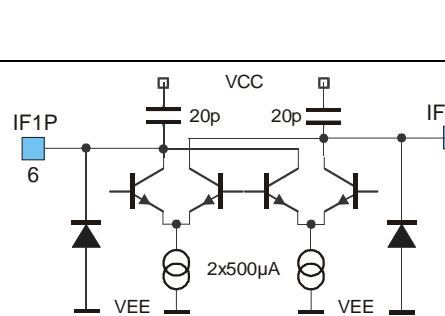
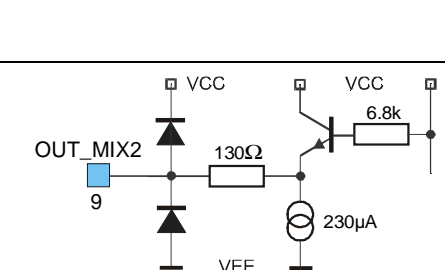
Pin No.	Name	I/O Type	Functional Schematic	Description
3	OUT_LNA	analog output		LNA open-collector output, to be connected to external LC tank that resonates at RF
31	IN_LNA	analog input		LNA input, approx. 26Ω single-ended
1	VEE_LNAC	ground		ground of LNA core (cascode)
2	GAIN_LNA	analog input		LNA gain control (CMOS input with hysteresis)
4	IN_MIX1	analog input		MIX1 input, approx. 33Ω single-ended
5	VEE_MIX	ground		LNA biasing ground
6	IF1P	analog I/O		open-collector output, to be connected to external LC tank that resonates at first IF
7	IF1N	analog I/O		open-collector output, to be connected to external LC tank that resonates at first IF
8	VCC_MIX	supply		MIX1 and MIX2 positive supply
9	OUT_MIX2	analog output		MIX2 output, approx. 330Ω output impedance
10	VEE_IF	ground		ground for MIX2, IFA and DEMOD

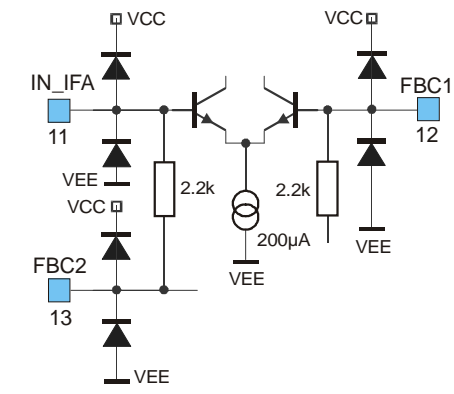
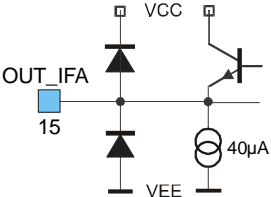
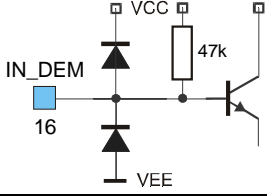
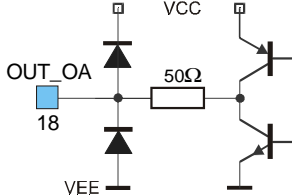
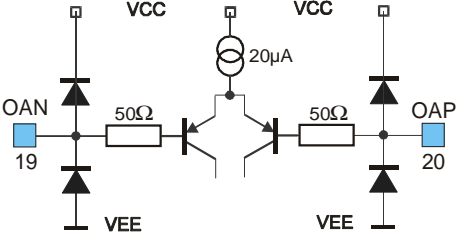
Pin No.	Name	I/O Type	Functional Schematic	Description
11	IN_IFA	analog input		IFA input, approx. 2.2kΩ input impedance
12	FBC1	analog I/O		to be connected to external IFA feedback capacitor
13	FBC2	analog I/O		to be connected to external IFA feedback capacitor
14	VCC_IF	supply		positive supply for IFA, DEMOD
15	OUT_IFA	analog I/O		IFA output and MIX3 input (of DEMOD)
16	IN_DEM	analog input		DEMOD input, to MIX3 core
17	VCC_BIAS	supply		positive supply of general bias system and OA
18	OUT_OA	analog output		OA output, 40uA current drive capability
19	OAN	analog input		negative OA input, input voltage limited to approx. 0.7 V _{pp} between pins OAP and OAN
20	OAP	analog input		negative OA input, input voltage limited to approx. 0.7 V _{pp} between pins OAP and OAN

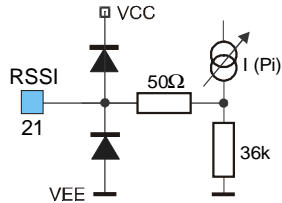
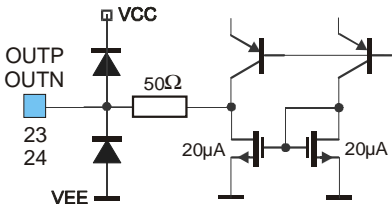
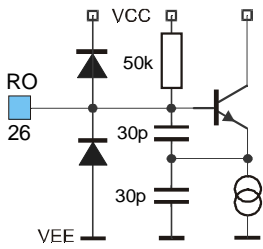
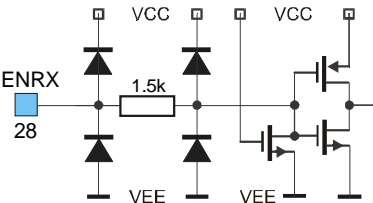
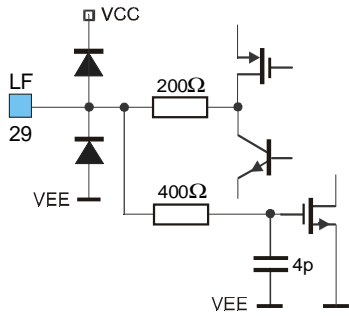
Pin No.	Name	I/O Type	Functional Schematic	Description
21	RSSI	analog output		RSSI output, for RSSI and ASK detection, approx. 36kΩ output impedance
22	VEE_BIAS	ground		ground for general bias system and OA
23	OUTP	analog output		FSK/FM positive output, output impedance of 100kΩ to 300kΩ
24	OUTN	analog		FSK/FM negative output, output impedance of 100kΩ to 300kΩ
25	VEE_RO	ground		ground of dividers, PFD and RO
26	RO	analog input		RO input, Colpitts type oscillator with internal feedback capacitors
27	VCC_PLL	supply		positive supply of RO, DIV, PFD and charge pump
28	ENRX	digital input		mode control input (CMOS Input)
29	LF	analog output		charge pump output and VCO1 control input
30	VEE_LNA	ground		LNA biasing ground
32	VCC_LNA	supply		positive supply of LNA biasing

Technical Data

Mode Configurations

ENRX	Mode	Description
0	SBY	standby mode
1	ON	entire chip active

Note: ENRX are pulled down internally

LNA Gain Control

V_{GAIN_LNA}	Mode	Description
< 0.8 V	HIGH GAIN	LNA set to high gain by voltage at GAIN_LNA
> 1.4 V	LOW GAIN	LNA set to low gain by voltage at GAIN_LNA

Note: hysteresis between gain modes to ensure stability

Absolute Maximum Ratings

Parameter	Symbol	Condition / Note	Min	Max	Unit
Supply voltage	V_{CC}		0	7.0	V
Input voltage	V_{IN}		- 0.3	$V_{CC}+0.3$	V
Input RF level	P_{imax}	no damage		10	dBm
Storage temperature	T_{STG}		-40	+125	°C
Electrostatic discharge	ESD	human body model, MIL STD 833D method 3015.7, all pins except OUT_IFA pin OUT_IFA	-500 -500	+500 +250	V V

Normal Operating Conditions

Parameter	Symbol	Condition	Min	Max	Unit
Supply voltage	V_{CC}		2.5	5.5	V
Operating temperature	T_a		-40	+85	°C
Input frequency	f_i		300	450	MHz
Frequency deviation	Δf	at FM or FSK	± 5	± 120	kHz
FSK data rate	R_{FSK}	NRZ		40	kbit/s
FM bandwidth	f_m			15	kHz
ASK data rate	R_{ASK}	NRZ		80	kbit/s

DC Characteristics

all parameters under normal operating conditions, unless otherwise stated;
typical values at $T_a = 23\text{ °C}$ and $V_{cc} = 3\text{ V}$

Parameter	Symbol	Condition	Min	Typ	Max	Unit
Standby current	I_{SBY}	ENRX=0			100	nA
Total supply current at low gain	$I_{cc, low}$	ENRX=1, LNA at LOW GAIN	5.0	6.5	8.0	mA
Total supply current at high gain	$I_{cc, high}$	ENRX=1, LNA at HIGH GAIN	6.5	8.2	10.0	mA
Opamp input offset voltage	V_{offs}		-20		20	mV
Opamp input offset current	I_{offs}	$I_{OAP} - I_{OAN}$	-50		50	nA
Opamp input bias current	I_{bias}	$0.5 * (I_{OAP} + I_{OAN})$	-100		100	nA
RSSI voltage at low input level	$V_{RSSI, low}$	$P_1 = -65\text{ dBm}$, LNA at LOW GAIN	0.5	1.0	1.5	V
RSSI voltage at high input level	$V_{RSSI, high}$	$P_1 = -35\text{ dBm}$, LNA at LOW GAIN	1.25	1.9	2.45	V

AC System Characteristics

all parameters under normal operating conditions, unless otherwise stated;
all parameters based on test circuits for FSK (Fig. 2), FM (Fig. 4) and ASK (Fig. 5), respectively;
typical values at $T_a = 23\text{ °C}$ and $V_{cc} = 3\text{ V}$, RF at 433.6 MHz, second IF at 10.7 MHz

Parameter	Symbol	Condition	Min	Typ	Max	Unit
start-up time – FSK/FM	T_{FSK}	ENRX from 0 to 1, valid data at output			0.9	ms
start-up time – ASK	T_{ASK}	depends on ASK detector time constant, valid data at output			$R3 \cdot C12$ + T_{FSK}	ms
input sensitivity – FSK (narrow band)	$P_{min, n}$	$B_{IF2} = 40\text{ kHz}$ $\Delta f = \pm 15\text{ kHz}$ (FSK/FM) $BER \leq 3 \cdot 10^{-3}$		-111		dBm
input sensitivity – FSK (wide band)	$P_{min, w}$	$B_{IF2} = 150\text{ kHz}$ $\Delta f = \pm 50\text{ kHz}$ (FSK/FM) $BER \leq 3 \cdot 10^{-3}$		-104		dBm
input sensitivity – ASK (narrow band)	$P_{minA, n}$	$B_{IF2} = 40\text{ kHz}$ $BER \leq 3 \cdot 10^{-3}$		-109		dBm
input sensitivity – ASK (wide band)	$P_{minA, w}$	$B_{IF2} = 150\text{ kHz}$ $BER \leq 3 \cdot 10^{-3}$		-106		dBm
maximum input signal – FSK/FM	$P_{max, FM}$	$BER \leq 3 \cdot 10^{-3}$ LNA at LOW GAIN		0		dBm
maximum input signal – ASK	$P_{max, ASK}$	$BER \leq 3 \cdot 10^{-3}$ LNA at LOW GAIN		-10		dBm
spurious emission	P_{spur}				-70	dBm
image rejection	ΔP_{imag}			65		dB
blocking immunity	ΔP_{block}	$\Delta f_{block} > \pm 2\text{ MHz}$, note 1		57		dB
VCO gain	K_{VCO}			250		MHz/V
Charge pump current	I_{CP}			60		μA

Notes: 1. desired signal with FSK/FM or ASK modulation, CW blocking signal

FSK test circuit component list to Fig. 2

Part	Size	Value / Type	Tolerance	Description
C1	0805	15 pF	±10%	crystal series capacitor
C3	0805	1 nF	±10%	loop filter capacitor
C4	0603	3.3 pF	±5%	capacitor to match to SAW filter input
C5	0603	3.3 pF	±5%	capacitor to match to SAW filter output
C6	0603	4.7 pF	±5%	LNA output tank capacitor
C7	0603	2.2 pF	±5%	MIX1 input matching capacitor
C8	0603	27 pF	±5%	IF1 tank capacitor
C9	0805	33 nF	±10%	IFA feedback capacitor
C10	0603	1 nF	±10%	IFA feedback capacitor
C11	0603	1 nF	±10%	IFA feedback capacitor
C12	0603	1.5 pF	±5%	DEMODO phase-shift capacitor
C13	0603	680 pF	±10%	DEMODO coupling capacitor
CP	0805	10 – 12 pF	±5%	CERRES parallel capacitor
C14	0805	10 – 47 pF	±5%	demodulator output low-pass capacitor, depending on data rate
C15	0805	10 – 47 pF	±5%	demodulator output low-pass capacitor, depending on data rate
C16	0603	330 pF	±10%	RSSI output low-pass capacitor
R1	0805	10 kΩ	±10%	loop filter resistor
L1	0603	33 nH	±5%	inductor to match SAW filter
L2	0603	33 nH	±5%	inductor to match SAW filter
L3	0603	15 nH	±5%	LNA output tank inductor
L4	0805	100 nH	±5%	IF1 tank inductor
L5	0805	100 nH	±5%	IF1 tank inductor
XTAL	HC49 SMD	23.49444 MHz @ RF = 433.6 MHz	±25ppm calibration ±30ppm temp.	fundamental-mode crystal, C _{load} = 10 pF to 15pF, C _{0, max} = 7 pF, R _{m, max} = 50 Ω
SAWFIL	QCC8C	B3555 @ RF = 433.6 MHz	B _{3dB} = 860 kHz ±100 kHz (f ₀ = 433.92 MHz)	low-loss SAW filter from EPCOS
CERFIL	leaded type	SFE10.7MFP @ B _{IF2} = 40 kHz	TBD	ceramic filter from Murata
	SMD type	SFECV10.7MJS-A @ B _{IF2} = 150 kHz	±40 kHz	
CERRES	SMD type	CDACV10.7MG18-A		ceramic demodulator tank from Murata

NIP – not in place, may be used optionally

FSK Circuit with AFC and Ceramic Resonator Tolerance Compensation

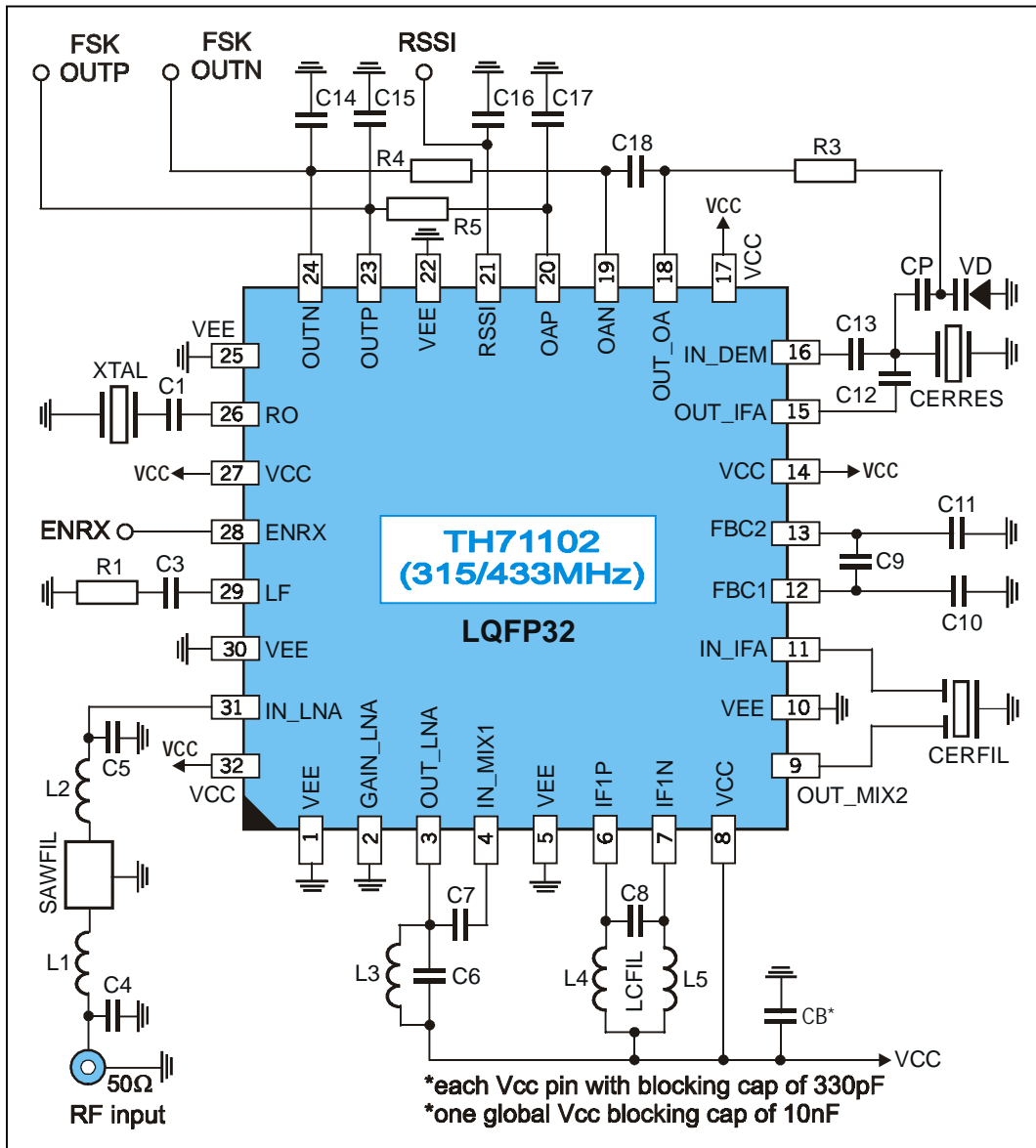

Fig. 3: Test circuit for FSK with AFC and resonator compensation

Circuit Feature

- Improves input frequency acceptance range up to $RF_{nom} \pm 50$ kHz
- Eliminates calibration tolerances of ceramic resonator
- Eliminates temperature tolerances of ceramic resonator
- Non-inverted and inverted CMOS-compatible outputs

FSK test circuit with AFC component list to Fig. 3

Part	Size	Value / Type	Tolerance	Description
C1	0805	15 pF	±10%	crystal series capacitor
C3	0805	1 nF	±10%	loop filter capacitor
C4	0603	3.3 pF	±5%	capacitor to match to SAW filter input
C5	0603	3.3 pF	±5%	capacitor to match to SAW filter output
C6	0603	4.7 pF	±5%	LNA output tank capacitor
C7	0603	2.2 pF	±5%	MIX1 input matching capacitor
C8	0603	27 pF	±5%	IF1 tank capacitor
C9	0805	33 nF	±10%	IFA feedback capacitor
C10	0603	1 nF	±10%	IFA feedback capacitor
C11	0603	1 nF	±10%	IFA feedback capacitor
C12	0603	1.5 pF	±5%	DEMOM phase-shift capacitor
C13	0603	680 pF	±10%	DEMOM coupling capacitor
CP	0805	27 pF	±5%	ceramic resonator loading capacitor
C14	0805	10 – 47 pF	±5%	demodulator output low-pass capacitor, depending on data rate
C15	0805	10 – 47 pF	±5%	demodulator output low-pass capacitor, depending on data rate
C16	0603	330 pF	±10%	RSSI output low-pass capacitor
C17		33 nF	±10%	integrator capacitor, fixed
C18	0805	33 nF	±10%	integrator capacitor, @ 0.5 to 2 kbit/s NRZ
		10 nF		integrator capacitor, @ 2 to 20 kbit/s NRZ
		1 nF		integrator capacitor, @ 20 to 40 kbit/s NRZ
R1	0805	10 kΩ	±10%	loop filter resistor
R3	0805	100 kΩ	±10%	varactor diode biasing resistor
R4	0805	680 kΩ	±10%	integrator resistor
R5	0805	680 kΩ	±10%	integrator resistor
L1	0603	33 nH	±5%	inductor to match SAW filter
L2	0603	33 nH	±5%	inductor to match SAW filter
L3	0603	15 nH	±5%	LNA output tank inductor
L4	0805	100 nH	±5%	IF1 tank inductor
L5	0805	100 nH	±5%	IF1 tank inductor
VD	SOD-323	BB535		varactor diode from Infineon
XTAL	HC49 SMD	23.49444 MHz @ RF = 433.6 MHz	±25ppm calibration ±30ppm temp.	fundamental-mode crystal, C _{load} = 10 pF to 15pF, C _{0, max} = 7 pF, R _{m, max} = 50 Ω
SAWFIL	QCC8C	B3555 @ RF = 433.6 MHz	B _{3dB} = 860 kHz ±100 kHz (f ₀ = 433.92 MHz)	low-loss SAW filter from EPCOS
CERFIL	leaded type	SFE10.7MFP @ B _{IF2} = 40 kHz	TBD	ceramic filter from Murata
	SMD type	SFECV10.7MJS-A @ B _{IF2} = 150 kHz	±40 kHz	
CERRES	SMD type	CDACV10.7MG18-A		ceramic demodulator tank from Murata

NIP – not in place, may be used optionally

FM Reception

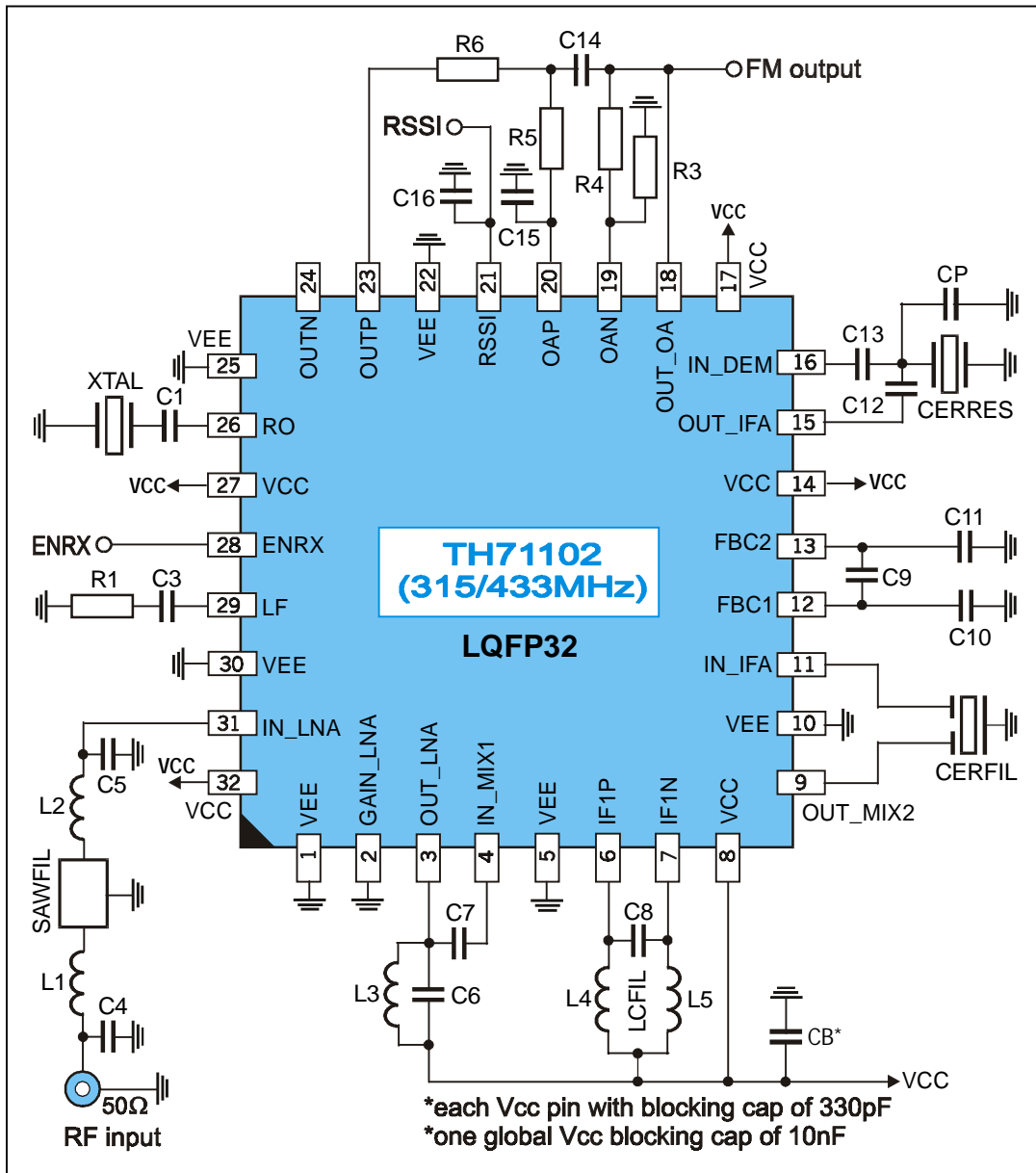

Fig. 4: Test circuit for FM reception

FM test circuit component list to Fig. 4

Part	Size	Value / Type	Tolerance	Description
C1	0805	15 pF	±10%	crystal series capacitor
C3	0805	1 nF	±10%	loop filter capacitor
C4	0603	3.3 pF	±5%	capacitor to match to SAW filter input
C5	0603	3.3 pF	±5%	capacitor to match to SAW filter output
C6	0603	4.7 pF	±5%	LNA output tank capacitor
C7	0603	2.2 pF	±5%	MIX1 input matching capacitor
C8	0603	27 pF	±5%	IF1 tank capacitor
C9	0805	33 nF	±10%	IFA feedback capacitor
C10	0603	1 nF	±10%	IFA feedback capacitor
C11	0603	1 nF	±10%	IFA feedback capacitor
C12	0603	1.5 pF	±5%	DEMODO phase-shift capacitor
C13	0603	680 pF	±10%	DEMODO coupling capacitor
CP	0805	10 – 12 pF	±5%	CERRES parallel capacitor
C14	0805	100 pF	±5%	sallen-Key low-pass filter capacitor, to set cut-off frequency
C15	0805	100 pF	±5%	sallen-Key low-pass filter capacitor, to set cut-off frequency
C16	0603	330 pF	±10%	RSSI output low-pass capacitor
R1	0805	10 kΩ	±10%	loop filter resistor
R3	0805	12 kΩ	±5%	sallen-Key filter resistor, to set desired filter characteristic
R4	0805	6.8 kΩ	±5%	sallen-Key filter resistor, to set desired filter characteristic
R5	0805	33 kΩ	±5%	sallen-Key filter resistor, to set cut-off frequency
R6	0805	33 kΩ	±5%	sallen-Key filter resistor, to set cut-off frequency
L1	0603	33 nH	±5%	inductor to match SAW filter
L2	0603	33 nH	±5%	inductor to match SAW filter
L3	0603	15 nH	±5%	LNA output tank inductor
L4	0603	100 nH	±5%	IF1 tank inductor
L5	0603	100 nH	±5%	IF1 tank inductor
XTAL	HC49 SMD	23.49444 MHz @ RF = 433.6 MHz	±25ppm calibration ±30ppm temp.	fundamental-mode crystal, C _{load} = 10 pF to 15pF, C _{0, max} = 7 pF, R _{m, max} = 50 Ω
SAWFIL	QCC8C	B3555 @ RF = 433.6 MHz	B _{3dB} = 860 kHz ±100 kHz (f ₀ = 433.92 MHz)	low-loss SAW filter from EPCOS
CERFIL	leaded type	SFE10.7MFP @ B _{IF2} = 40 kHz	TBD	ceramic filter from Murata
	SMD type	SFECV10.7MJS-A @ B _{IF2} = 150 kHz	±40 kHz	
CERRES	SMD type	CDACV10.7MG18-A		ceramic demodulator tank from Murata

NIP – not in place, may be used optionally

ASK Reception

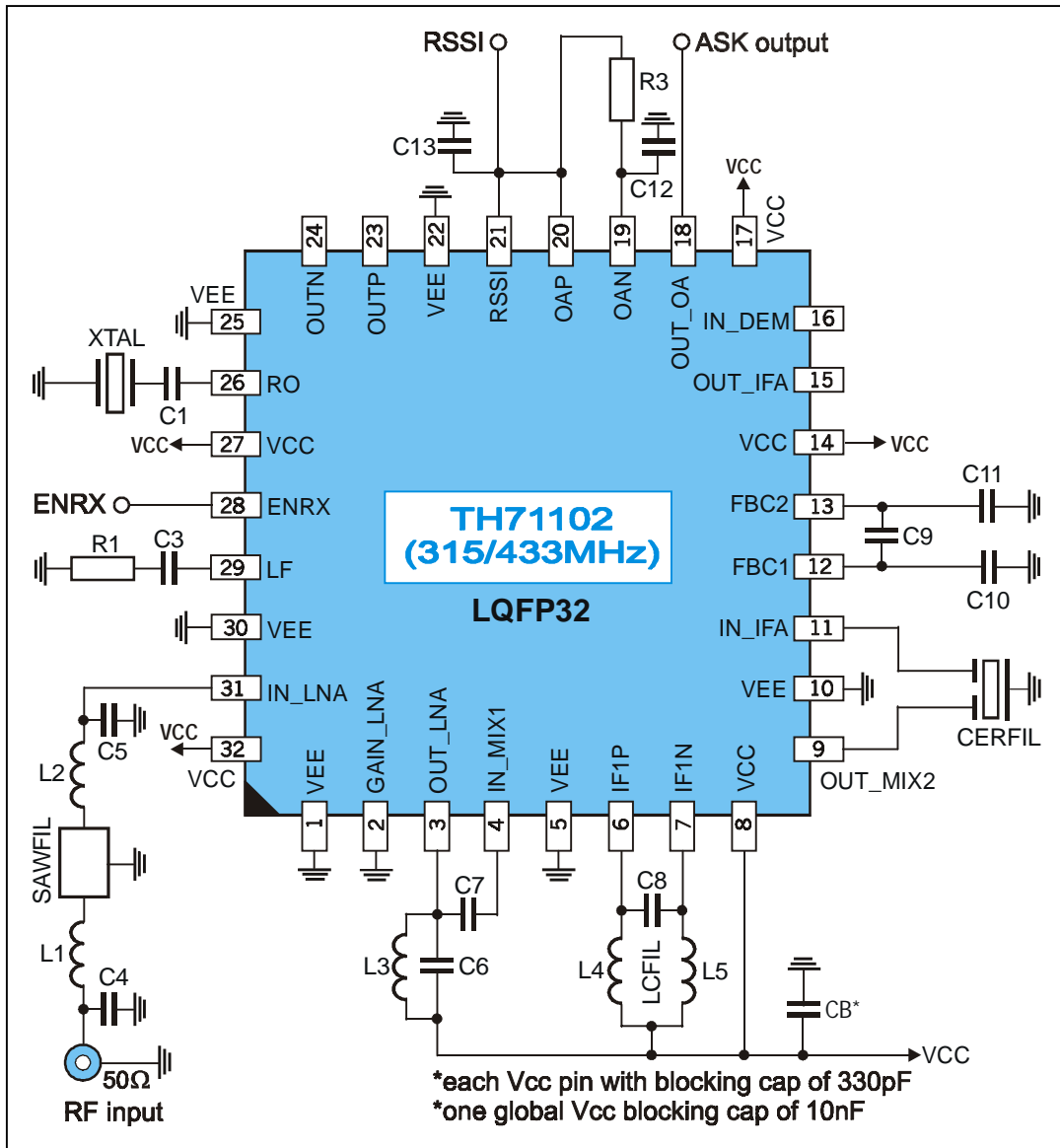

Fig. 5: Test circuit for ASK reception

ASK test circuit component list to Fig. 5

Part	Size	Value / Type	Tolerance	Description
C1	0805	15 pF	±10%	crystal series capacitor
C3	0805	1 nF	±10%	loop filter capacitor
C4	0603	3.3 pF	±5%	capacitor to match to SAW filter input
C5	0603	3.3 pF	±5%	capacitor to match to SAW filter output
C6	0603	4.7 pF	±5%	LNA output tank capacitor
C7	0603	2.2 pF	±5%	MIX1 input matching capacitor
C8	0805	27 pF	±5%	IF1 tank capacitor
C9	0805	33 nF	±10%	IFA feedback capacitor
C10	0603	1 nF	±10%	IFA feedback capacitor
C11	0603	1 nF	±10%	IFA feedback capacitor
C12	0805	1 nF to 10 nF	±10%	ASK data slicer capacitor, depending on data rate
C13	0603	330 pF	±10%	RSSI output low-pass capacitor
R1	0805	10 kΩ	±10%	loop filter resistor
R3	0603	100 kΩ	±5%	ASK data slicer resistor, depending on data rate
L1	0603	33 nH	±5%	inductor to match SAW filter
L2	0603	33 nH	±5%	inductor to match SAW filter
L3	0603	15 nH	±5%	LNA output tank inductor
L4	0603	100 nH	±5%	IF1 tank inductor
L5	0603	100 nH	±5%	IF1 tank inductor
XTAL	HC49 SMD	23.49444 MHz @ RF = 433.6 MHz	±25ppm calibration ±30ppm temp.	fundamental-mode crystal, C _{load} = 10 pF to 15pF, C _{0, max} = 7 pF, R _{m, max} = 50 Ω
SAWFIL	QCC8C	B3555 @ RF = 433.6 MHz	B _{3dB} = 860 kHz ±100 kHz (f ₀ = 433.92 MHz)	low-loss SAW filter from EPCOS
CERFIL	leaded type	SFE10.7MFP @ B _{IF2} = 40 kHz	TBD	ceramic filter from Murata
	SMD type	SFECV10.7MJS-A @ B _{IF2} = 150 kHz	±40 kHz	

NIP – not in place, may be used optionally

Package Dimensions

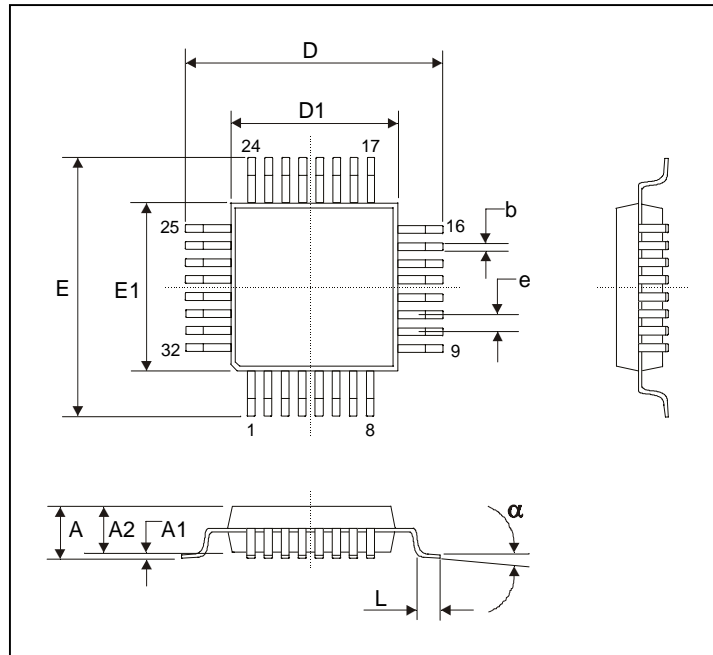

Fig. 6: LQFP32 (Low Quad Flat Package)

All Dimension in mm, coplanarity < 0.1mm									
	E1, D1	A	A1	A2	e	b	L	E, D	α
min			0.05	1.35		0.30	0.45		0°
max	7.00	1.60	0.15	1.45	0.8	0.45	0.75	9.00	7°
All Dimension in inch, coplanarity < 0.004"									
min			0.002	0.053		0.012	0.018		0°
max	0.276	0.630	0.006	0.057	0.031	0.018	0.030	0.354	7°

Your Notes

Your Notes

Important Notice

Devices sold by Melexis are covered by the warranty and patent indemnification provisions appearing in its Term of Sale. Melexis makes no warranty, express, statutory, implied, or by description regarding the information set forth herein or regarding the freedom of the described devices from patent infringement. Melexis reserves the right to change specifications and prices at any time and without notice. Therefore, prior to designing this product into a system, it is necessary to check with Melexis for current information. This product is intended for use in normal commercial applications. Applications requiring extended temperature range, unusual environmental requirements, or high reliability applications, such as military, medical life-support or life-sustaining equipment are specifically not recommended without additional processing by Melexis for each application.

The information furnished by Melexis is believed to be correct and accurate. However, Melexis shall not be liable to recipient or any third party for any damages, including but not limited to personal injury, property damage, loss of profits, loss of use, interrupt of business or indirect, special incidental or consequential damages, of any kind, in connection with or arising out of the furnishing, performance or use of the technical data herein. No obligation or liability to recipient or any third party shall arise or flow out of Melexis' rendering of technical or other services.

© 2000 Melexis GmbH. All rights reserved.

For the latest version of this document. Go to our website at
www.melexis.com

Or for additional information contact Melexis Direct:

Europe and Japan:
Phone: +32 1361 1631
E-mail: sales_europe@melexis.com

All other locations:
Phone: +1 603 223 2362
E-mail: sales_usa@melexis.com