

Features

- Pixel Size: 11 μm x 13 μm (13 μm Pitch)
- High Data Output Rate: 20 MHz
- High Responsivity and Resolution Over a Wide Spectral Range: from Blue (400 nm) up to Near Infrared (1,100 nm)
- Low Dark Signal and Improved Uniformity
- Low Temporal Noise and High Dynamic Range: Over 6000/1
- Ease and Flexibility of Operation:
 - Only Two External Basic Drive Clocks
 - Choice of Internal or External Sampling and Reset
- 28-lead DIL Package
- Available with Standard Window or Antireflective Window in the Bandwidth 450 to 750 nm

Pin Identification

Pin Number	Symbol	Designation
2	V _{OSA}	Video Output Signal A (Odd Channel)
3	Φ_{ECHA}	A Sample-and-hold Gate Input Channel
4	S Φ_{ECHA}	A Internal Sampling Clock Output Channel
5	Φ_{RA}	A External Reset Clock Input Channel
9	V _{DD}	Output Amplifier Drain And Internal Logic Supply
10	TP3	Test Point 3
11	TP2	Test Point 2
12	VT	Register and Photosensitive Zone DC Bias
13	TP1	Test Point 1
14, 15, 28	V _{SS}	Substrate Bias (Ground)
16	V _{INH}	Internal Sampling Clock Inhibiting Input (Dc Bias)
18	Φ_{P}	Transfer Clock
19	Φ_{T}	Register Transport Clock
20	V _{GS}	Output Gate DC Bias
21	Φ_{RB}	B External Reset Clock Output Channel
24	S Φ_{ECHB}	B Internal Sampling Clock Output Channel
25	Φ_{ECHB}	B Sample-and-hold Gate Input Channel
26	V _{OSB}	Video Output Signal B (Even Channel)
27	V _{DR}	Reset DC Bias
1, 6, 7, 8, 17, 22, 23	DNC	Do not Connect

DNC	1	28	VSS
VOSA	2	27	VDR
Φ_{ECHA}	3	26	VOSB
S Φ_{ECHA}	4	25	Φ_{ECHB}
Φ_{RA}	5	24	S Φ_{ECHB}
DNC	6	23	DNC
DNC	7	22	DNC
DNC	8	21	Φ_{RB}
VDD	9	20	VGS
TP3	10	19	Φ_{T}
TP2	11	18	Φ_{P}
VT	12	17	DNC
TP1	13	16	VINH
VSS	14	15	VSS



Linear CCD Image Sensor (2048 Pixels)

TH7841A



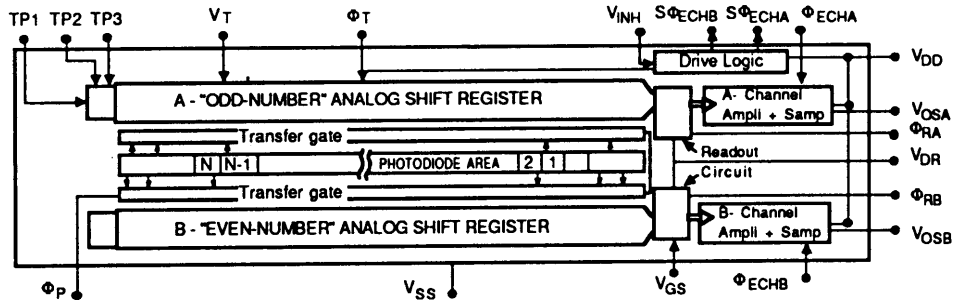

Absolute Maximum Ratings*

Storage Temperature	-55°C to +150°C
Operating Temperature	0°C to +70°C
Thermal Cycling	15°C/mn
Maximum Voltages:	
• Pins: 3, 5, 9, 10, 11, 13, 16, 19, 20, 21, 25, 27	-0.3V to +18V
• Pins: 12, 18	-0.3V to +16V
• Pins: 14, 15, 28	0V

*NOTICE: Stresses above those listed under ABSOLUTE MAXIMUM RATINGS may cause permanent device failure. Functionality at or above these limits is not implied. Exposure to absolute maximum ratings for extended periods may affect device reliability.

Operating Range

Operating range defines the temperature limits between which the functionality is guaranteed: 0°C to 70°C.

Operating Precautions

Shorting the video output to V_{SS} to V_{DD} , even temporarily, can permanently damage the output amplifier.

Operating Conditions (T = 25°C)

Table 1. DC Characteristics

Parameter	Symbol	Values			Unit	Note
		Min	Typ	Max		
Output Amplifier Drain Supply	V _{DD}	14	15	16	V	
Reset DC Bias	V _{DR}	12	13	14.5	V	(1)
Output Gate DC Bias	V _{GS}	5.5	6	6.5	V	
Photosensitive Zone and Register DC Bias	V _T	6	6.5	7	V	(2)
Substrate Bias	V _{SS}	0.0	0.0			
Test Point 1	TP1		V _{DD}		V	(3)
Test Points 2 and 3	TP2, TP3		V _{SS}		V	(3)

Notes: 1. It is recommended to maintain V_{DR} at V_{DD} - 2V.

2. V_T nominal =

$$\frac{(V\Phi_T)_{high} + (V\Phi_T)_{low}}{2} \pm 5\%$$

3. No use for operation – For testing purpose only.

Basic Internal Configuration

SΦ_{ECHA} and Φ_{RA} | internal to TH7841A
 SΦ_{ECHB} and Φ_{RB} |

Table 2. Selection of Nominal Mode

Option	Implementation	Note
Internal Sampling	V _{INH} (16) Connected to V _{SS} SΦ _{ECHA} (4) and Φ _{ECHA} (3) Strapped SΦ _{ECHB} (24) and Φ _{ECHB} (25) Strapped	(1)
Internal Reset	Φ _{RA} (5) and Φ _{RB} (21) Connected to VDD	

Note: 1. Make the straps as short as possible to avoid any parasitic coupling to these connections. The load capacitance introduced by the strap should not exceed 5 pF.

Figure 1. Timing Diagram — Clocks and Video Output Timing Diagram in Internal Sampling Mode

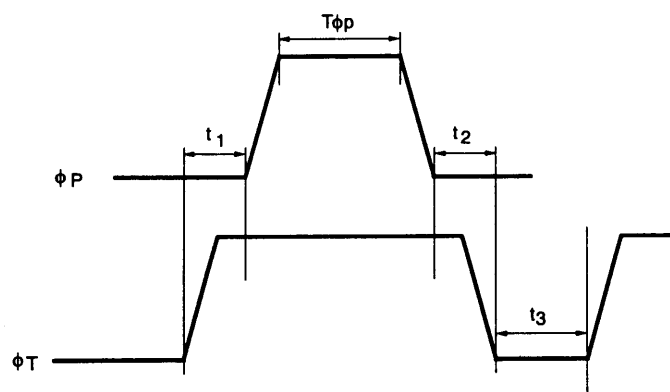
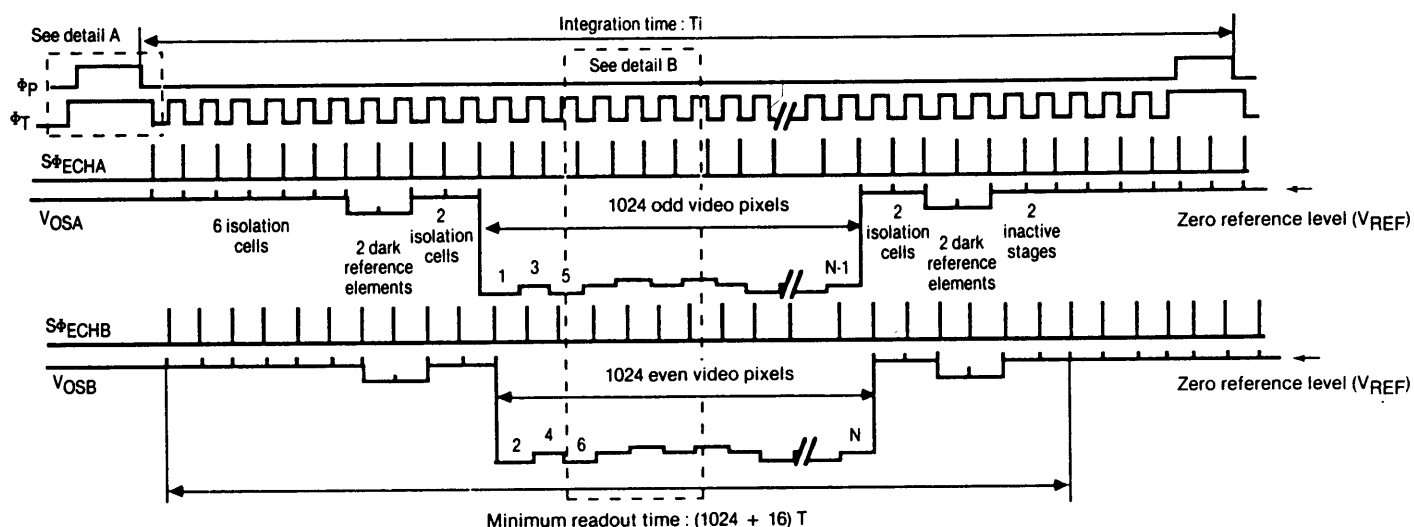

Detail A

$T_{\phi P}$: Minimum value : 100 ns
 Recommended 0.5 to 1 μ s
 t_1 and $t_3 > 0$ $t_2 >$ or < 0
 ϕ_P = pulse may end before or after ϕ_T returns to the low level

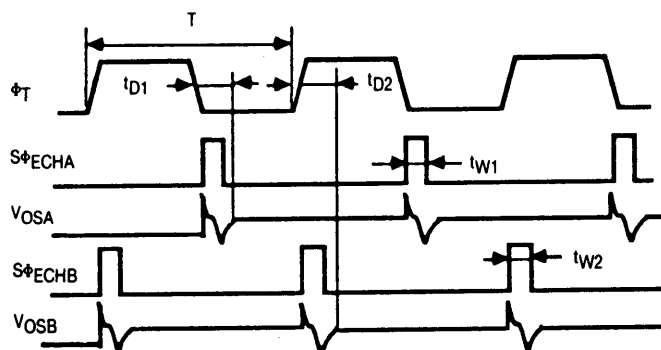

Detail B

ϕ_T : duty cycle : 50 \pm 10 %
 rise and fall time > 15 ns
 $t_{W1} = t_{W2} = 30$ ns typ.
 $t_{D1} = t_{D2} = 50$ ns typ.

Table 3. Drive Clock Characteristics (see Figure 1)

Parameter	Symbol	Logic	Values			Unit	Note
			Min	Typ	Max		
Transfer Clock	$\Phi_P \Phi_T$	High	12	13	14	V	(1)
Register Transport Clock		Low	0.0	0.4	0.6		
Register Transport Clock Capacitance	C_{Φ_T}			800	1200	pF	
Transfer Clock Capacitance	C_{Φ_P}			200	300	pF	

Note: 1. Transients under 0.0V in the clock pulses will lead to charge injection, causing a localized increase in the dark signal if such spurious negative transients are present, they can be suppressed by inserting a serial resistor of appropriate value (typically 20 to 100 Ω) in the corresponding driver output.

Table 4. Static and Dynamic Electrical Characteristics

Parameter	Symbol	Values			Unit	Note
		Min	Typ	Max		
DC Output Level	V_{REF}	8	10	12	V	
Output Impedance	Z_S		500		Ω	
Register Single-stage Transfer Efficiency	CTE	99.992	99.998		%	$V_{OS} = 1V^{(1)}$
Max. Data Output Frequency	F_S max.	12	20		MHz	⁽²⁾
Input Current on Pins: 3, 5, 10,11,12, 13, 18, 19, 20, 21, 25	I_e			2	μA	$V_e = 15V$ All other pins: 0V
Peak Current Sink on Φ_T Clock	$(I\Phi_T)_P$		500		mA	$t_{rise} = 15 ns$
Peak Current Sink on Φ_P Clock	$(I\Phi_P)_P$		125		mA	$t_{rise} = 15 ns$
Output Amplifier Drain Supply Current	I_{DD}		17		mA	$V_{INH} = 0V$ $V_{DD} = 15V$
Static Power Dissipation	P_D		255	300	mW	$V_{INH} = 0V$ $V_{DD} = 15V$

Notes: 1. V_{OS} = average video output voltage. Measurement excludes first and last pixels.
 2. $F_S = 2F\Phi_T$. The minimum clock frequency is limited by the increase in dark signal.

Electro-optical Performance

General measurement conditions: $T_C = 25^\circ C$; $T_i = 1 ms$; $F\Phi_T = 2.5 MHz$.

Light source: tungsten filament lamp (2854 K) + BG 38 filter (2 mm thick) + F/3.5 aperture. The filter limits the spectrum to 700 nm; in these conditions, $1 \mu J/cm^2$ corresponds to 3.5 lux.s.

Typical operating conditions; internal clock mode (see Table 2).

First and last pixels, as well as reference elements, are excluded from the specification.

Measurements taken on each output in succession.

Table 5. Electro-optical Performance

Parameter	Symbol	Values			Unit	Note
		Min	Typ	Max		
Saturation Output Voltage	V_{SAT}	1.3	1.8	2.2	V	(1)(2)
Saturation Exposure	E_{SAT}		0.33		$\mu\text{J}/\text{cm}^2$	
Responsivity	R	2.5	2.9		$\text{V}/\mu\text{J}/\text{cm}^2$	
Responsivity Unbalance	$\Delta R/R$		2	8	%	(3)
Photo-response No-uniformity Peak-to-peak	PRNU		± 5	± 10	% V_{OS}	$V_{OS} = 50 \text{ mV to } 1\text{V}$
Contrast Transfer Function at FN (38 l p/mm)	CTF		70		%	$V_{OS} = 0.75\text{V}$
Temporal Noise in Darkness			160		μVrms	(4)
Dynamic Range (Relative to rms Noise)	DR	3000	6000			
Average Dark Signal	V_{DS}		0.08	0.5	mV	(1)
Dark Signal Non-uniformity	DSNU		0.15	0.5	mV	

Notes: 1. Value measured with respect to zero reference level (see Figure 1).

2. Conversion factor is typically $1.1 \mu\text{V}/\text{e}^-$.

3. $\Delta R/R$ is defined as

$$\frac{200|RA - RB|}{RA + RB}$$

where RA is responsivity of video output A

RB is responsivity of video output B

4. Measured in Correlated Double Sampling (C.D.S.) mode.

Figure 2. Typical Spectral Response

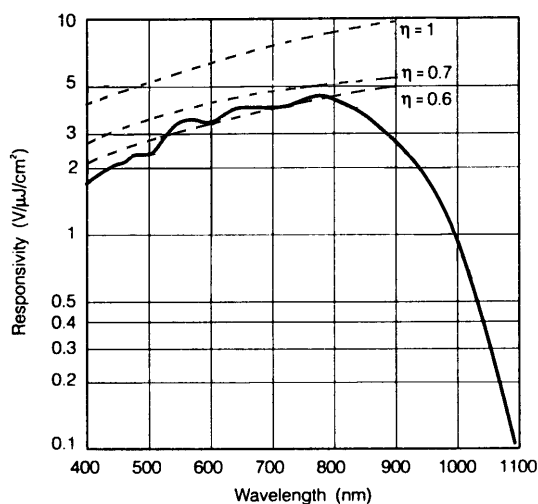
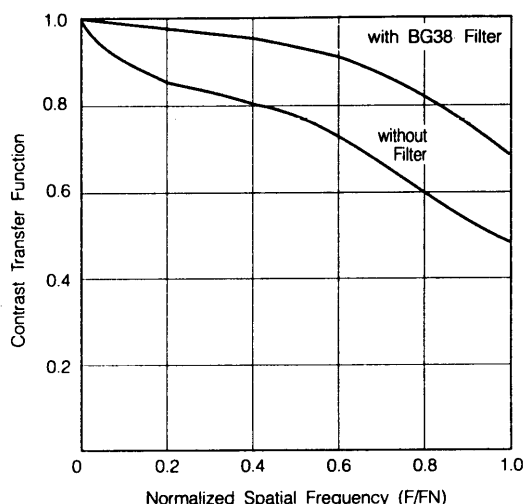

Figure 3. CTF Typical Curves (2854 K Source)



Electro-optical Performance Without Infrared Cut-off Filtering

The TH7841A special semiconductor process exploits the silicon’s high near infrared sensitivity while maintaining good imaging performance in terms of response uniformity and resolution. Typical changes in performance with and without IR filtering are summarized below.

	With IR Cut-off Filter	No IR Cut-off Filter
Average Video Signal Due To a Given Scene Illumination	V_{OS}	$V_{OS} \times 4$
PRNU (Single Defects Excluded)	$\pm 5\%$	$\pm 5\%$
CTF at Nyquist Frequency	70%	50%

Complementary Operating Modes

The TH7841A may be used in several configurations in regards to video output sampling and charge sensing reset.

1. Sampling options

Inhibition of internal sampling pulses allows two possibilities:

- a. no sampling: video output delivered in unsampled form,
- b. sampling by external clocks: external sampling pulses directly applied to Φ_{ECHA} , Φ_{ECHB} inputs.

If internal sampling clocks $S\Phi_{ECHA}$ and $S\Phi_{ECHB}$ are not used, it is recommended to unpower the corresponding clock drivers, as this will greatly reduce on-chip power consumption.

2. External reset position

The position and period of the charge reset clocks may be optimized by using external clocks on Φ_{RA} and Φ_{RB} inputs. This is especially interesting to optimize the video outputs for Correlated Double Sampling (in order to reduce noise and improve S/N Ratio).

Control signals to be applied in the different configurations are shown in Table 6.



Table 6. Selection of Operating Modes

Option	Implementation	Note
No Sampling	Φ_{ECHA} (3) and Φ_{ECHB} (25) Connected to VDD $S\Phi_{ECHA}$ (4) and $S\Phi_{ECHB}$ (24) Unconnected V_{INH} (16) Connected to V_{DD}	(1)
Sampling By External Clocks	Sampling Clocks Connected to Φ_{ECHA} - Φ_{ECHB} $S\Phi_{ECHA}$ and $S\Phi_{ECHB}$ Unconnected V_{INH} (16) Connected to V_{DD}	See Figure 4 for sampling clock timing ⁽¹⁾
Reset Control By External Clocks	Ext. Φ_{RA} on Φ_{RA} (5) Input Ext. Φ_{RB} on Φ_{RB} (21) Input	See Figure 4 for reset clock timing

Note: 1. Drain supply current I_{DD} decreases from 10 mA to 8 mA typically when internal sampling clock is disabled ($V_{INH} = V_{DD} = 15V$).

Table 7. External Φ_{RA} , Φ_{RB} , Φ_{ECHA} , Φ_{ECHB} Clocks Characteristics

Parameter	Symbol	Logic	Values			Unit
			Min	Typ	Max	
External Reset Clock Sampling Clock	$\Phi_{RA}, \Phi_{RB},$ Φ_{ECHA}, Φ_{ECHB}	High	12	13	14	V
		Low	0.0	0.4	0.6	V
Reset And Sampling Clock Capacitance	$C\Phi_{RA}$ $C\Phi_{RB}$ $C\Phi_{ECHA}$ $C\Phi_{ECHB}$			10	15	pF

Insertion of a serial resistor (typically 100 Ω) at the driver output avoids spurious negative transients.

Figure 4. Timing Diagram — Clocks and Video Output Timing Diagram With and Without On-chip Sampling

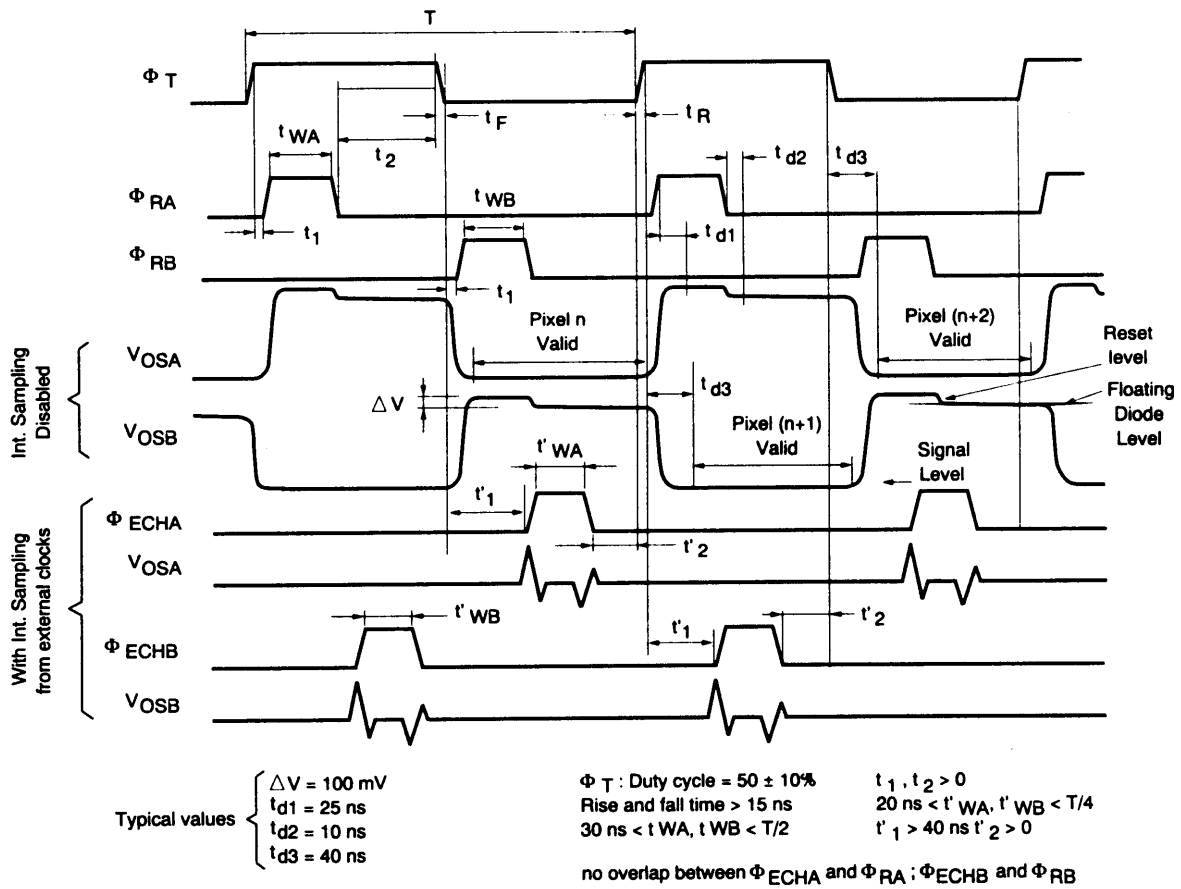

Table 8. Performance Improvement with External Φ_{RA} , Φ_{RB} Configuration⁽¹⁾⁽²⁾

Parameter	Symbol	Values	Unit
		(Typ)	
Saturation Output Voltage	V_{SAT}	2.0	V
Responsivity	R	5.0	$V/\mu\text{J}/\text{cm}^2$
Dynamic Range	DR	8,000	

- Notes: 1. Electro-optical performances obtained with complementary modes are not guaranteed for standard products.
 2. The Conversion factor is typically $1.8 \mu\text{V}/e^-$.

TH7841A With Antireflective Window

Improvements in the bandwidth 450-750 nm:

- 5% increase in responsivity (typical value: 3.0 V/μJ/cm²).
- limitation of the parasitic reflections.

Package Drawing

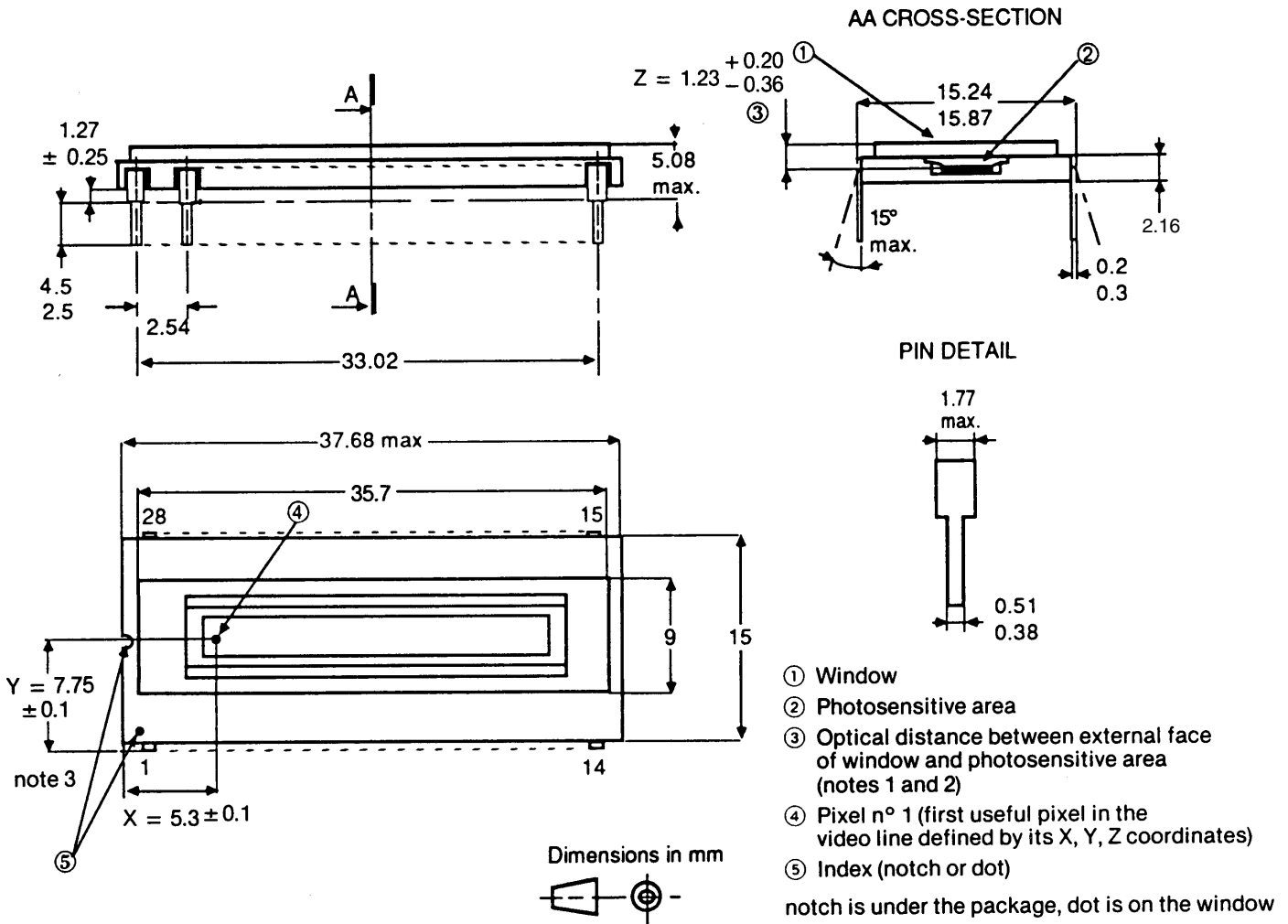

- Notes:
1. If an optical reference is needed, it is recommended to use the window face plane.
 2. Variation of Z (azimuth) on the photosensitive area of a device is ≤ 0.1 mm
 3. Variation of Y between the first and the last pixel of the linear area is $\leq \pm 130$ μm.

Ordering Code

The ordering code is: TH7841 ACC-R



Atmel Headquarters

Corporate Headquarters
2325 Orchard Parkway
San Jose, CA 95131
TEL 1(408) 441-0311
FAX 1(408) 487-2600

Europe

Atmel Sarl
Route des Arsenaux 41
Case Postale 80
CH-1705 Fribourg
Switzerland
TEL (41) 26-426-5555
FAX (41) 26-426-5500

Asia

Room 1219
Chinachem Golden Plaza
77 Mody Road Tsimhatsui
East Kowloon
Hong Kong
TEL (852) 2721-9778
FAX (852) 2722-1369

Japan

9F, Tonetsu Shinkawa Bldg.
1-24-8 Shinkawa
Chuo-ku, Tokyo 104-0033
Japan
TEL (81) 3-3523-3551
FAX (81) 3-3523-7581

Atmel Operations

Memory

2325 Orchard Parkway
San Jose, CA 95131
TEL 1(408) 441-0311
FAX 1(408) 436-4314

Microcontrollers

2325 Orchard Parkway
San Jose, CA 95131
TEL 1(408) 441-0311
FAX 1(408) 436-4314

La Chantrerie
BP 70602
44306 Nantes Cedex 3, France
TEL (33) 2-40-18-18-18
FAX (33) 2-40-18-19-60

ASIC/ASSP/Smart Cards

Zone Industrielle
13106 Rousset Cedex, France
TEL (33) 4-42-53-60-00
FAX (33) 4-42-53-60-01

1150 East Cheyenne Mtn. Blvd.
Colorado Springs, CO 80906
TEL 1(719) 576-3300
FAX 1(719) 540-1759

Scottish Enterprise Technology Park
Maxwell Building
East Kilbride G75 0QR, Scotland
TEL (44) 1355-803-000
FAX (44) 1355-242-743

RF/Automotive

Theresienstrasse 2
Postfach 3535
74025 Heilbronn, Germany
TEL (49) 71-31-67-0
FAX (49) 71-31-67-2340

1150 East Cheyenne Mtn. Blvd.
Colorado Springs, CO 80906
TEL 1(719) 576-3300
FAX 1(719) 540-1759

Biometrics/Imaging/Hi-Rel MPU/ High Speed Converters/RF Datacom

Avenue de Rochepleine
BP 123
38521 Saint-Egreve Cedex, France
TEL (33) 4-76-58-30-00
FAX (33) 4-76-58-34-80

e-mail

literature@atmel.com

Web Site

<http://www.atmel.com>

© Atmel Corporation 2002.

Atmel Corporation makes no warranty for the use of its products, other than those expressly contained in the Company's standard warranty which is detailed in Atmel's Terms and Conditions located on the Company's web site. The Company assumes no responsibility for any errors which may appear in this document, reserves the right to change devices or specifications detailed herein at any time without notice, and does not make any commitment to update the information contained herein. No licenses to patents or other intellectual property of Atmel are granted by the Company in connection with the sale of Atmel products, expressly or by implication. Atmel's products are not authorized for use as critical components in life support devices or systems.

ATMEL® is the registered trademark of Atmel.

Other terms and product names may be the trademarks of others.



Printed on recycled paper.