



# THD277HI

## HIGH VOLTAGE FAST-SWITCHING NPN POWER TRANSISTOR

- STMicroelectronics PREFERRED SALESTYPE
- HIGH VOLTAGE CAPABILITY
- U.L. RECOGNISED ISOWATT218 PACKAGE (U.L. FILE # E81734 (N)).

### APPLICATIONS

- HORIZONTAL DEFLECTION FOR COLOUR TV AND MONITORS
- SWITCH MODE POWER SUPPLIES

### DESCRIPTION

This device is manufactured using Multi-epitaxial Mesa technology for cost-effective high performance and uses a Hollow Emitter structure to enhance switching speeds.

The THD series are designed for use in horizontal deflection circuits in televisions and monitors.

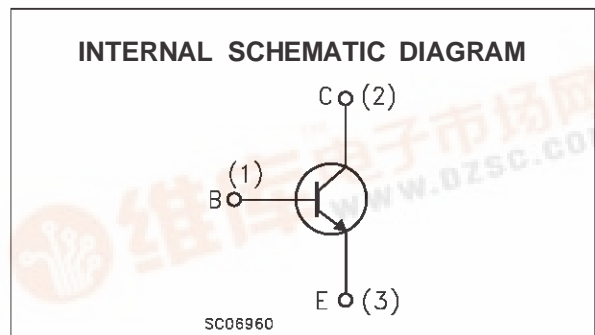
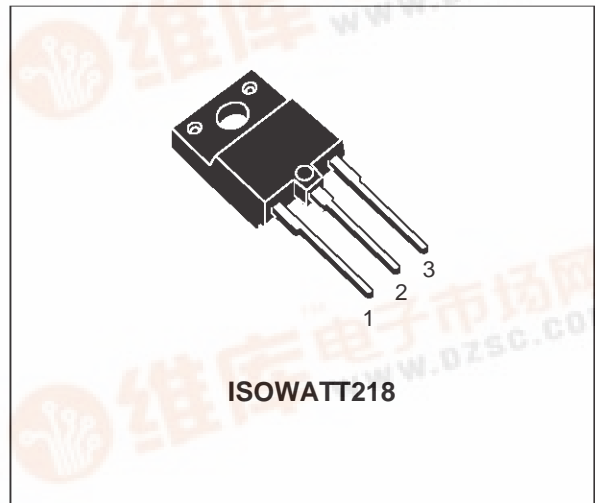

### ABSOLUTE MAXIMUM RATINGS

Symbol	Parameter	Value	Unit
$V_{CBO}$	Collector-Base Voltage ( $I_E = 0$ )	1500	V
$V_{CEO}$	Collector-Emitter Voltage ( $I_B = 0$ )	700	V
$V_{EBO}$	Emitter-Base Voltage ( $I_C = 0$ )	10	V
$I_C$	Collector Current	8	A
$I_{CM}$	Collector Peak Current ( $t_p < 5$ ms)	15	A
$I_B$	Base Current	5	A
$I_{BM}$	Base Peak Current ( $t_p < 5$ ms)	8	A
$P_{tot}$	Total Dissipation at $T_c = 25$ °C	50	W
$T_{stg}$	Storage Temperature	-65 to 150	°C
$T_j$	Max. Operating Junction Temperature	150	°C



# THD277HI

## THERMAL DATA

$R_{thj-case}$	Thermal Resistance Junction-case	Max	2.5	°C/W
----------------	----------------------------------	-----	-----	------

## ELECTRICAL CHARACTERISTICS ( $T_{case} = 25\text{ °C}$ unless otherwise specified)

Symbol	Parameter	Test Conditions	Min.	Typ.	Max.	Unit
$I_{CES}$	Collector Cut-off Current ( $V_{BE} = 0$ )	$V_{CE} = 1500\text{ V}$			200	$\mu\text{A}$
$I_{EBO}$	Emitter Cut-off Current ( $I_C = 0$ )	$V_{EB} = 5\text{ V}$			50	$\mu\text{A}$
$V_{EBO}$	Emitter-Base Voltage	$I_E = 10\text{ mA}$	10			V
$V_{CEO(sus)}^*$	Collector-Emitter Sustaining Voltage ( $I_B = 0$ )	$I_C = 100\text{ mA}$	700			V
$V_{CE(sat)}^*$	Collector-Emitter Saturation Voltage	$I_C = 4\text{ A}$ $I_B = 1\text{ A}$			0.9	V
$V_{BE(sat)}^*$	Base-Emitter Saturation Voltage	$I_C = 4\text{ A}$ $I_B = 1\text{ A}$			1.3	V
$h_{FE}^*$	DC Current Gain	$I_C = 4\text{ A}$ $V_{CE} = 5\text{ V}$ $I_C = 4\text{ A}$ $V_{CE} = 5\text{ V}$ $T_j = 100\text{ °C}$	6 4		13	
$t_s$ $t_f$	RESISTIVE LOAD Storage Time Fall Time	$V_{CC} = 400\text{ V}$ $I_C = 4\text{ A}$ $I_{B1} = 1\text{ A}$ $I_{B2} = -2\text{ A}$		2.1 140	3.2 210	$\mu\text{s}$ ns
$t_s$ $t_f$	INDUCTIVE LOAD Storage Time Fall Time	$I_C = 4\text{ A}$ $f = 15625\text{ Hz}$ $I_{B1} = 1\text{ A}$ $I_{B2} = -2\text{ A}$ $V_{ceflyback} = 1050 \sin\left(\frac{\pi}{10} 10^6\right) t \text{ V}$		4.3 370		$\mu\text{s}$ ns
$t_s$ $t_f$	INDUCTIVE LOAD Storage Time Fall Time	$I_C = 4\text{ A}$ $f = 31250\text{ Hz}$ $I_{B1} = 1\text{ A}$ $I_{B2} = -2\text{ A}$ $V_{ceflyback} = 1050 \sin\left(\frac{\pi}{10} 10^6\right) t \text{ V}$		4.3 330		$\mu\text{s}$ ns

\* Pulsed: Pulse duration = 300  $\mu\text{s}$ , duty cycle 1.5 %

## Safe Operating Area

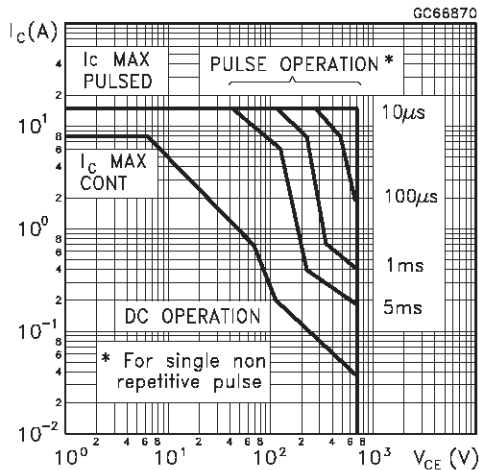

## Thermal Impedance

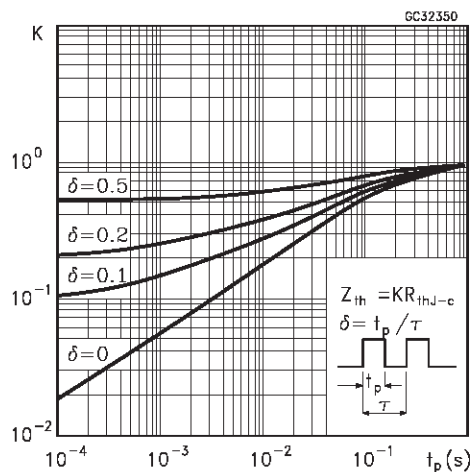

DC Current Gain

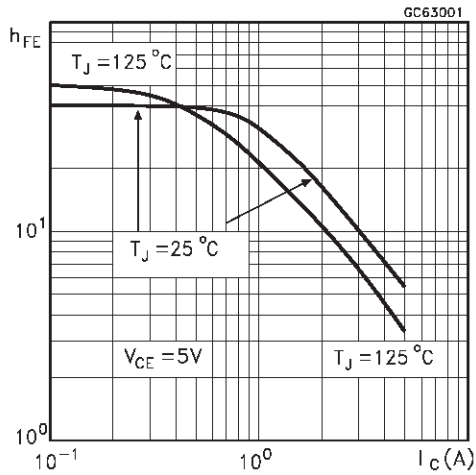

Collector Emitter Saturation Voltage

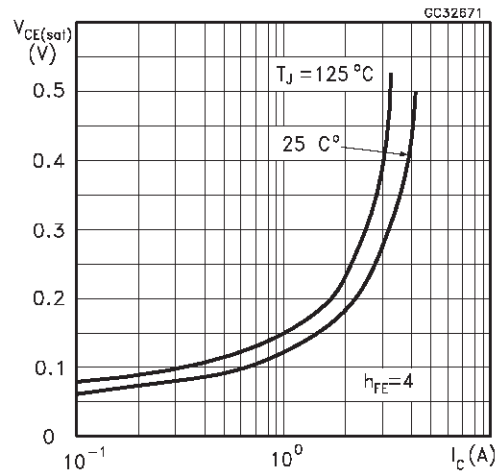

Base Emitter Saturation Voltage

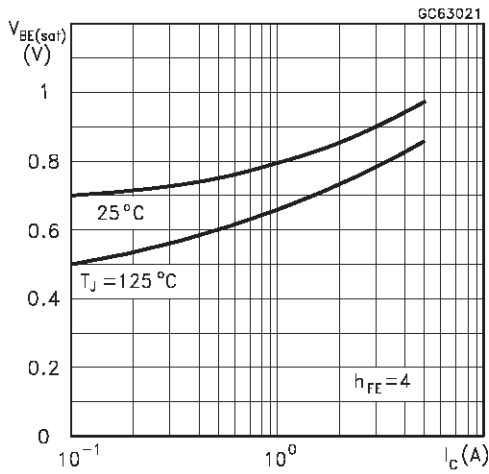

Switching Time Inductive Load

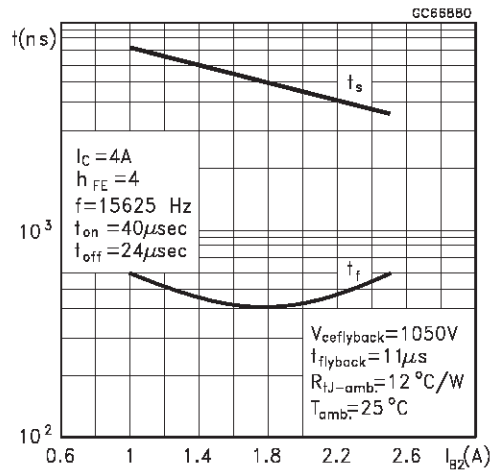

Switching Time Inductive Load

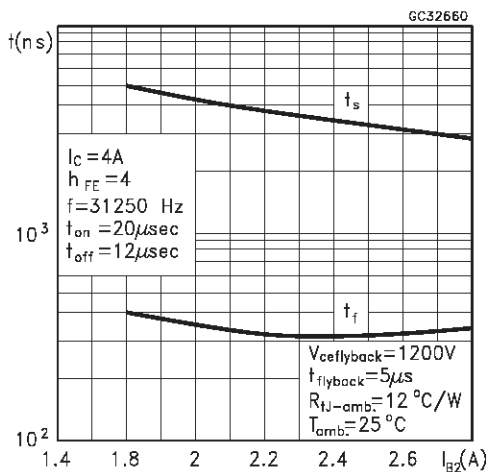

Reverse Biased SOA

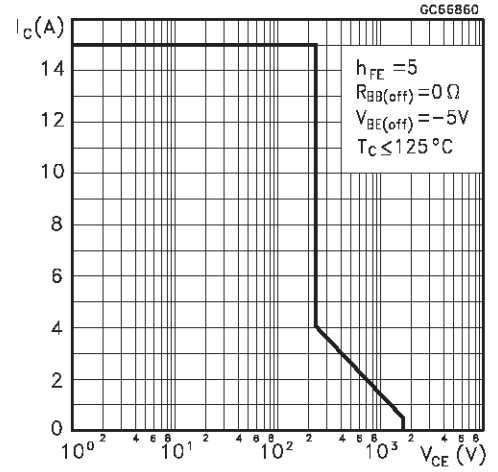

**ISOWATT218 MECHANICAL DATA**

DIM.	mm			inch		
	MIN.	TYP.	MAX.	MIN.	TYP.	MAX.
A	5.35		5.65	0.211		0.222
C	3.30		3.80	0.130		0.150
D	2.90		3.10	0.114		0.122
D1	1.88		2.08	0.074		0.082
E	0.75		0.95	0.030		0.037
F	1.05		1.25	0.041		0.049
F2	1.50		1.70	0.059		0.067
F3	1.90		2.10	0.075		0.083
G	10.80		11.20	0.425		0.441
H	15.80		16.20	0.622		0.638
L		9			0.354	
L1	20.80		21.20	0.819		0.835
L2	19.10		19.90	0.752		0.783
L3	22.80		23.60	0.898		0.929
L4	40.50		42.50	1.594		1.673
L5	4.85		5.25	0.191		0.207
L6	20.25		20.75	0.797		0.817
N	2.1		2.3	0.083		0.091
R		4.6			0.181	
DIA	3.5		3.7	0.138		0.146

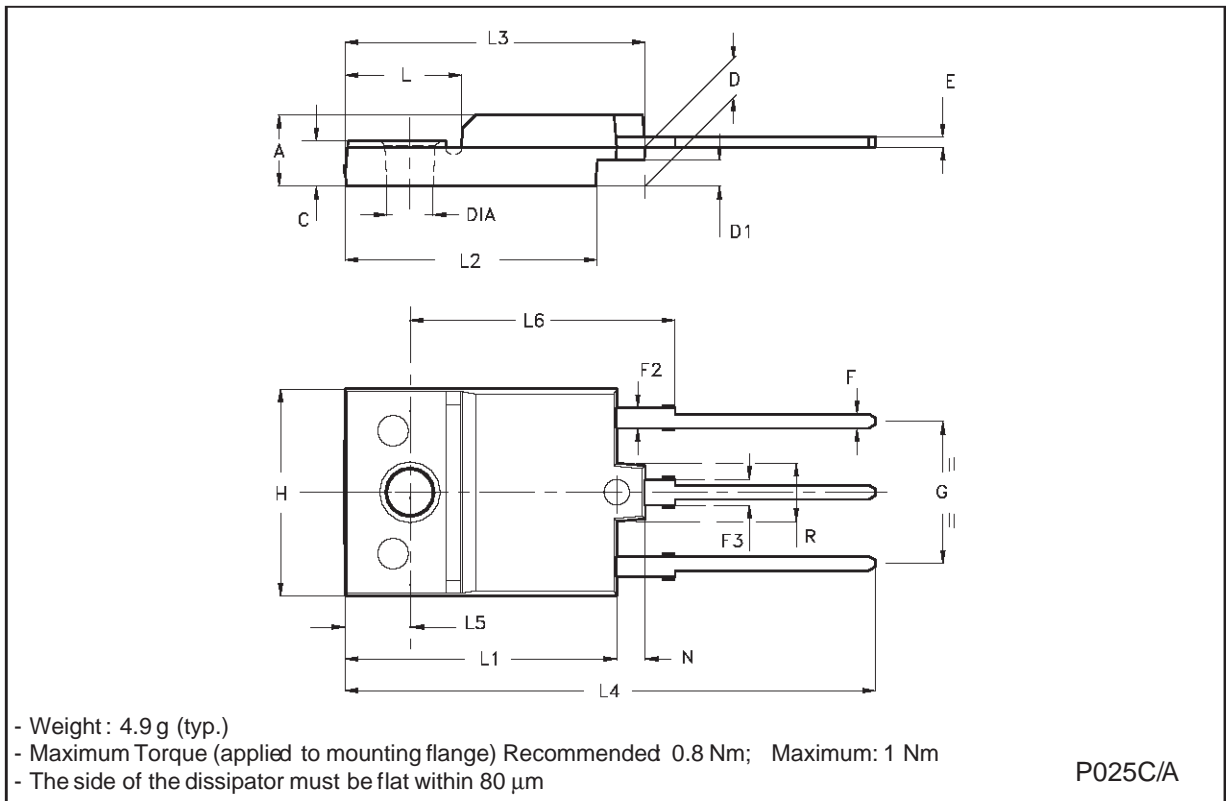

P025C/A

Information furnished is believed to be accurate and reliable. However, STMicroelectronics assumes no responsibility for the consequences of use of such information nor for any infringement of patents or other rights of third parties which may result from its use. No license is granted by implication or otherwise under any patent or patent rights of STMicroelectronics. Specification mentioned in this publication are subject to change without notice. This publication supersedes and replaces all information previously supplied. STMicroelectronics products are not authorized for use as critical components in life support devices or systems without express written approval of STMicroelectronics.

The ST logo is a trademark of STMicroelectronics

© 1999 STMicroelectronics – Printed in Italy – All Rights Reserved

STMicroelectronics GROUP OF COMPANIES

Australia - Brazil - China - Finland - France - Germany - Hong Kong - India - Italy - Japan - Malaysia - Malta - Morocco -  
Singapore - Spain - Sweden - Switzerland - United Kingdom - U.S.A.

<http://www.st.com>