

**NPN Planer RF TRANSISTOR**

**DESCRIPTION**

The THN6301S is a low Noise figure and good associated gain performance at UHF,VHF and Microwave frequencies  
It is suitable for a high density surface mount since transistor has been SOT23 package

**FEATURES**

- o Low Noise Figure  
N.F = 1.1dB TYP. @ f=1GHz, V<sub>CE</sub>=8V, I<sub>c</sub>=5mA
- o High Gain  
MAG = 16.5dB TYP. @ f=1GHz, V<sub>CE</sub>=8V, I<sub>c</sub>=15mA
- o High Transition Frequency  
f<sub>T</sub> = 10GHz TYP. @ f=1GHz, V<sub>CE</sub>=8V, I<sub>c</sub>=15mA

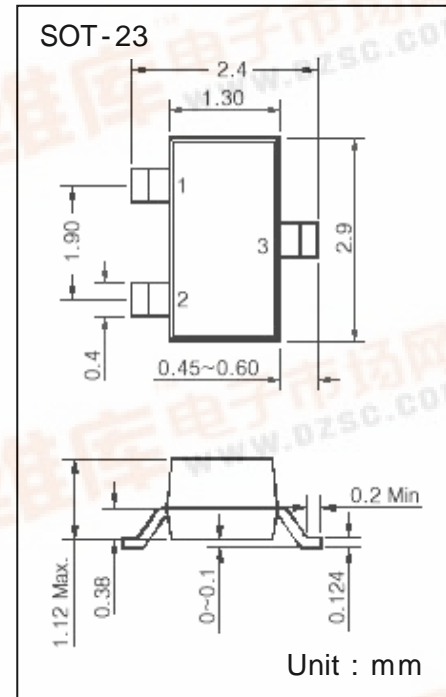

**PIN CONFIGURATION**

PIN NO	SYMBOL	DESCRIPTION
1	B	Base
2	E	Emitter
3	C	Collector

**MARKING : AA1**

**MAXIMUM RATINGS**

SYMBOL	PARAMETER	CONDITION	VALUE	Unit
V <sub>CB0</sub>	Collector-Base Voltage	Open Emitter	25	V
V <sub>CEO</sub>	Collector-Emitter Voltage	Open Base	12	V
V <sub>EBO</sub>	Emitter-Base Voltage	Open Collector	2.5	V
I <sub>c</sub>	Collector Current (DC)		65	mA
P <sub>T</sub>	Total Power Dissipation	T <sub>s</sub> = 60	150	mW
T <sub>STG</sub>	Storage Temperature		-65 ~ 150	
T <sub>J</sub>	Operating Junction Temperature		150	



**Electrical Characteristics (  $T_A = 25$  )**

SYMBOL	PARAMETER	CONDITION	VALUE			Unit
			min	typ	max	
V <sub>CB0</sub>	Collector-Base Voltage	I <sub>CE</sub> = 100uA, I <sub>E</sub> = 0	20	25		V
V <sub>CEO</sub>	Collector-Emitter Voltage	I <sub>CE</sub> = 100uA, I <sub>B</sub> = 0	12	14		V
I <sub>CB0</sub>	Collector-Cut-off current	V <sub>CB</sub> = 10V, I <sub>E</sub> = 0			100	n A
I <sub>EBO</sub>	Emitter-Cut-off current	V <sub>EB</sub> = 1V, I <sub>C</sub> = 0			100	n A
h <sub>fe</sub>	D.C Current Gain	V <sub>CE</sub> = 8V, I <sub>C</sub> = 15mA	100	200	300	
f <sub>T</sub>	Transition Frequency	V <sub>CE</sub> = 8V, I <sub>C</sub> = 15mA		10		GHz
C <sub>CB</sub>	Collector-Base Capacitance	V <sub>CB</sub> = 10V, f = 1MHz		0.60		pF

**Performance Characteristics**

SYMBOL	PARAMETER	CONDITION	VALUE			Unit
			min	typ	max	
[S <sub>21</sub> ] <sup>2</sup>	Insertion Power Gain	V <sub>CE</sub> =8V, I <sub>C</sub> =5mA, f=1GHz		11.5		dB
		V <sub>CE</sub> =8V, I <sub>C</sub> =15mA, f=1GHz		13.5		
MSG	Maximum Stable Gain	V <sub>CE</sub> =8V, I <sub>C</sub> =5mA, f=1GHz		15.5		dB
		V <sub>CE</sub> =8V, I <sub>C</sub> =15mA, f=1GHz		16.5		
NF <sub>min</sub>	Minimum Noise Figure	V <sub>CE</sub> =8V, I <sub>C</sub> =5mA, f=1GHz		1.1		dB
r <sub>n</sub>	Noise Resistance	V <sub>CE</sub> =8V, I <sub>C</sub> =5mA, f=1GHz		0.055		
G <sub>A</sub>	Associated Gain	V <sub>CE</sub> =8V, I <sub>C</sub> =5mA, f=1GHz		14.5		dB
		V <sub>CE</sub> =8V, I <sub>C</sub> =15mA, f=1GHz		15		
OIP <sub>3</sub>	Output 3rd Intercept	V <sub>CE</sub> =8V, I <sub>C</sub> =15mA, f=1GHz		27		dBm

**Total power dissipation**  $P_t = f(T_A)$   
 ( $T_A = 25^\circ\text{C}$ )

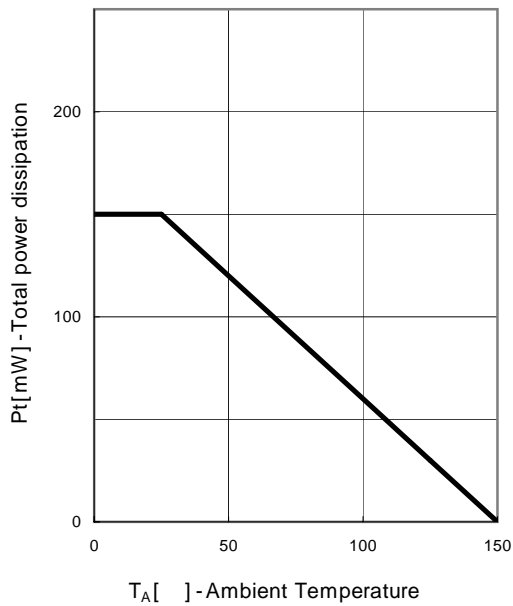

**Icc vs. VCE**

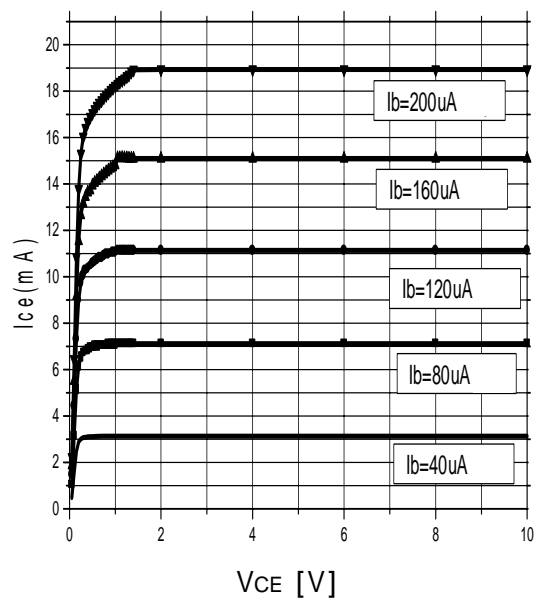

**Icc vs. VBE**

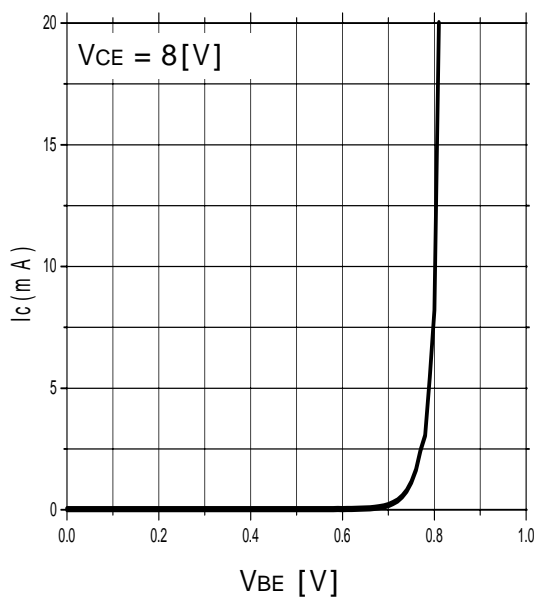

**hfe vs. Icc**

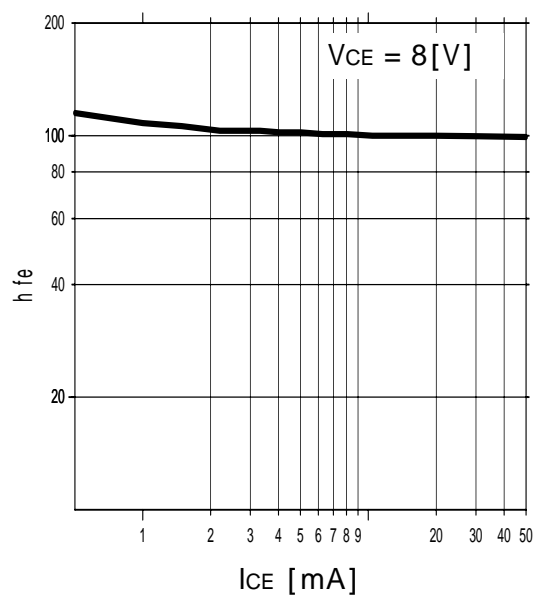

Power Gain : MSG vs. Frequency

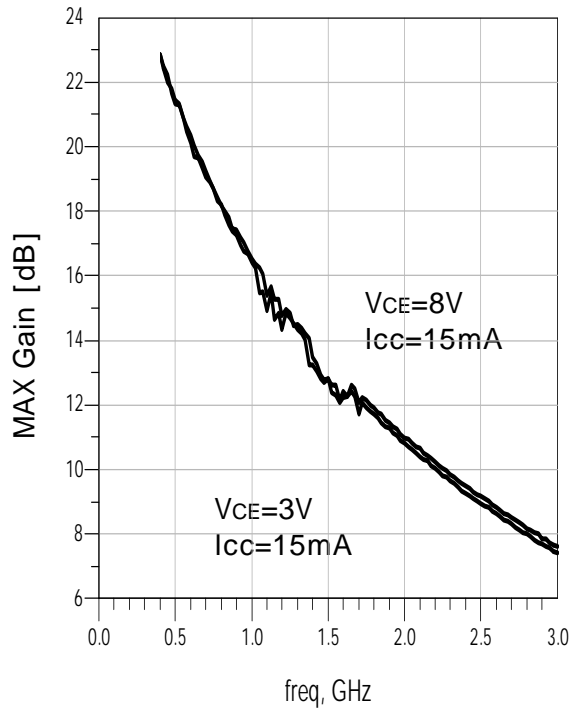

Power Gain :  $S_{21}$  vs. Frequency

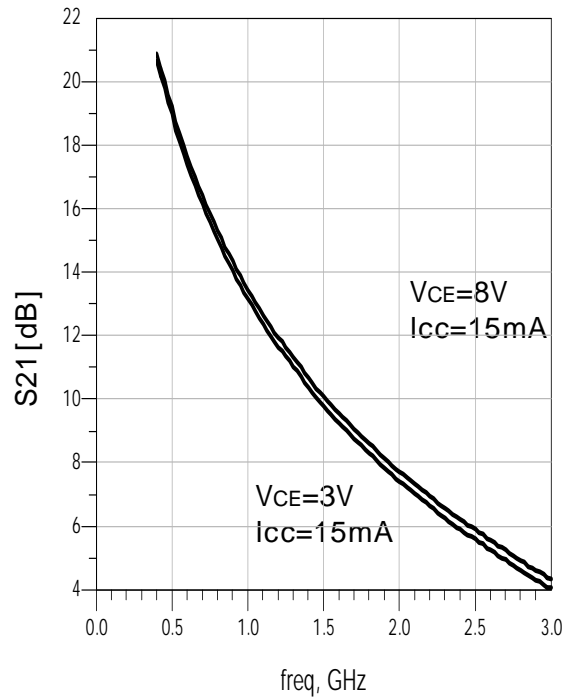

Transition Frequency :  $f_T$  vs.  $I_{CC}$

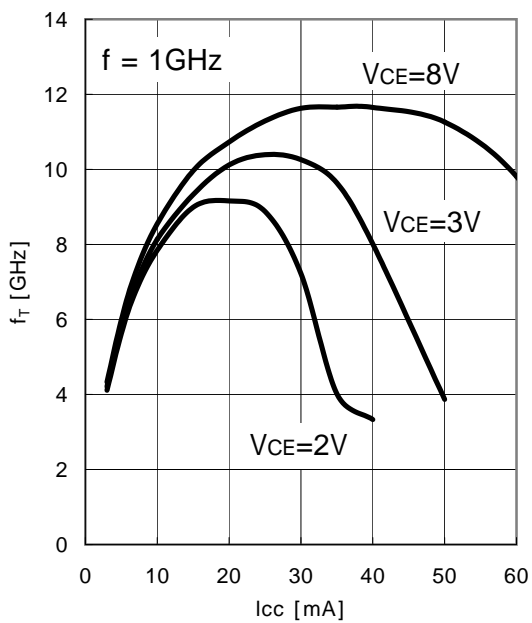

Power Gain : MSG vs.  $I_{CC}$

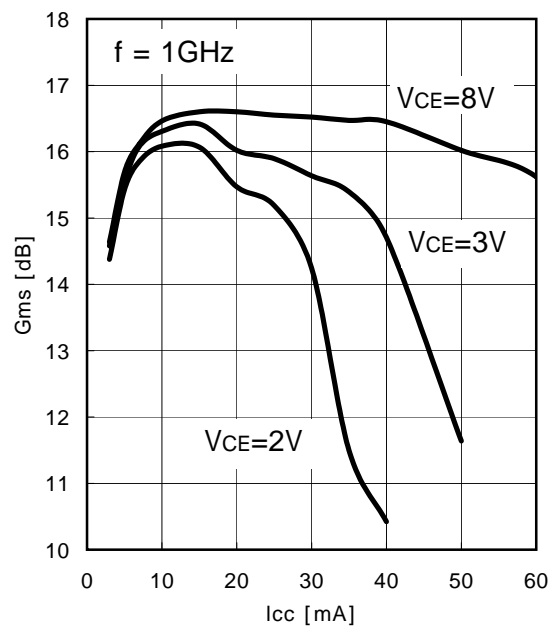

**Intermodulation Intercept Point  $IP_3=f(I_c)$**   
 ( $Z_S = Z_L = 50 \Omega$ )

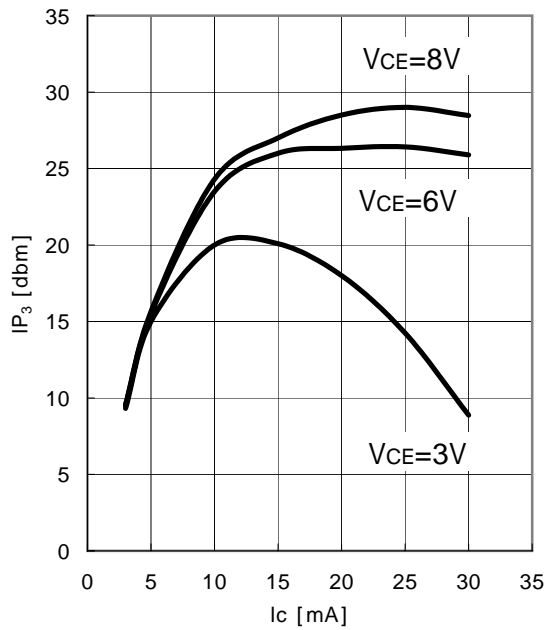

**CCB vs.  $V_{CB}$**

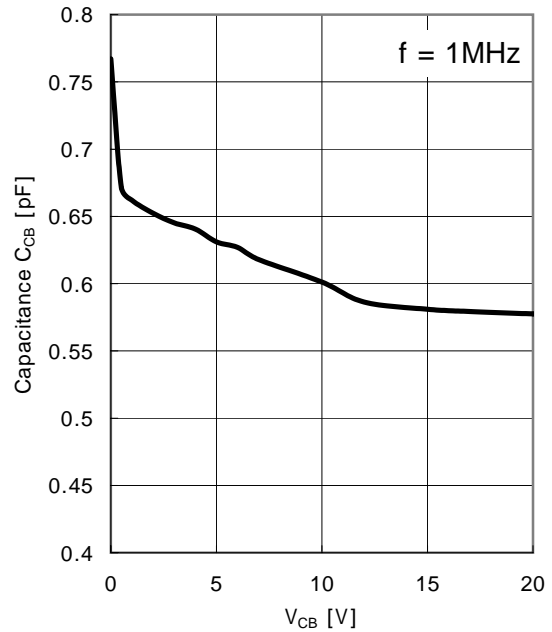

**Fmin vs.  $I_{cc}$**   
 $V_{CE} = 8V, I_{cc} = \text{parameter}, Z_s = Z_{opt}$

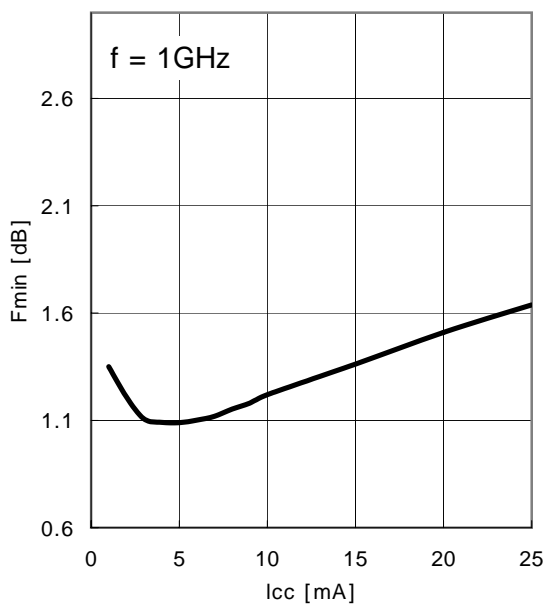

**Noise Figure Contours & Constant Gain**  
 $f = 1\text{GHz}, V_{CE} = 8V, I_{cc} = 5\text{mA}$

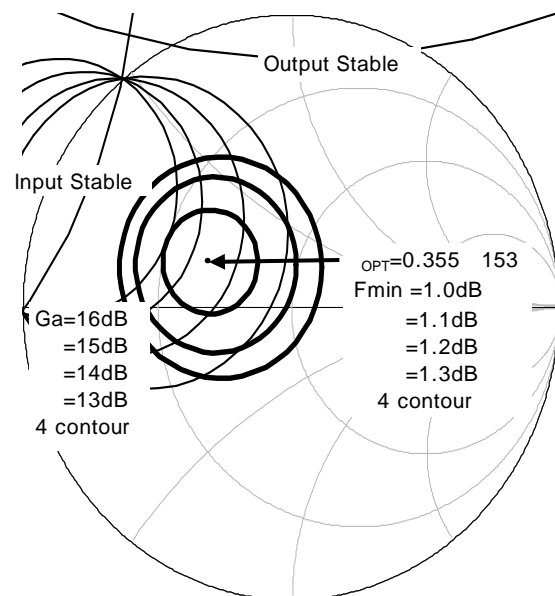

**Common Emitter S-Parameter Data**
**V<sub>CE</sub> = 3V, I<sub>CC</sub> = 3mA**

freq	S(1,1)	S(2,1)	S(1,2)	S(2,2)
400.0MHz	0.669 / -91.260	6.389 / 113.667	0.093 / 41.242	0.658 / -56.210
600.0MHz	0.591 / -116.551	4.795 / 97.539	0.106 / 34.002	0.554 / -69.347
800.0MHz	0.548 / -134.577	3.799 / 85.274	0.107 / 31.893	0.492 / -79.180
1.000GHz	0.530 / -148.770	3.121 / 75.149	0.109 / 34.373	0.461 / -88.098
1.200GHz	0.522 / -159.455	2.638 / 67.037	0.111 / 36.704	0.458 / -94.276
1.400GHz	0.524 / -169.504	2.291 / 58.719	0.117 / 40.679	0.462 / -103.617
1.600GHz	0.533 / -177.611	2.019 / 52.033	0.122 / 45.350	0.467 / -110.131
1.800GHz	0.543 / 174.468	1.804 / 45.454	0.135 / 49.642	0.483 / -116.174
2.000GHz	0.557 / 167.968	1.621 / 39.619	0.148 / 53.084	0.501 / -122.880
2.200GHz	0.569 / 161.134	1.478 / 34.016	0.166 / 55.353	0.518 / -129.476
2.400GHz	0.580 / 155.148	1.348 / 29.268	0.187 / 56.417	0.538 / -135.444
2.600GHz	0.596 / 149.582	1.244 / 24.067	0.210 / 56.426	0.559 / -142.351
2.800GHz	0.607 / 142.626	1.144 / 19.595	0.233 / 55.556	0.579 / -146.080
3.000GHz	0.614 / 137.215	1.059 / 16.254	0.255 / 54.303	0.605 / -152.161

**V<sub>CE</sub> = 3V, I<sub>CC</sub> = 5mA**

freq	S(1,1)	S(2,1)	S(1,2)	S(2,2)
400.0MHz	0.578 / -108.220	8.153 / 106.751	0.080 / 42.751	0.537 / -66.313
600.0MHz	0.524 / -131.976	5.878 / 92.628	0.090 / 40.339	0.440 / -78.796
800.0MHz	0.499 / -148.190	4.565 / 82.116	0.095 / 41.840	0.386 / -88.029
1.000GHz	0.489 / -160.975	3.713 / 73.353	0.104 / 43.842	0.366 / -96.568
1.200GHz	0.485 / -170.201	3.127 / 66.308	0.112 / 47.872	0.367 / -101.536
1.400GHz	0.491 / -179.049	2.708 / 58.910	0.124 / 49.734	0.376 / -110.217
1.600GHz	0.503 / 174.017	2.383 / 52.876	0.135 / 52.795	0.385 / -116.309
1.800GHz	0.513 / 167.188	2.133 / 46.876	0.150 / 54.802	0.401 / -121.481
2.000GHz	0.526 / 161.512	1.920 / 41.437	0.167 / 55.925	0.420 / -127.551
2.200GHz	0.539 / 155.297	1.754 / 36.122	0.187 / 56.242	0.437 / -133.592
2.400GHz	0.549 / 150.174	1.604 / 31.518	0.205 / 55.989	0.459 / -139.147
2.600GHz	0.567 / 145.239	1.483 / 26.473	0.227 / 55.156	0.482 / -145.317
2.800GHz	0.577 / 138.729	1.368 / 21.950	0.247 / 53.513	0.505 / -147.922
3.000GHz	0.582 / 133.719	1.274 / 18.402	0.267 / 52.001	0.533 / -153.890

**V<sub>CE</sub> = 3V, I<sub>CC</sub> = 10mA**

freq	S(1,1)	S(2,1)	S(1,2)	S(2,2)
400.0MHz	0.489 / -131.217	10.037 / 98.564	0.063 / 49.972	0.380 / -81.298
600.0MHz	0.465 / -151.502	6.988 / 87.307	0.076 / 50.120	0.311 / -92.732
800.0MHz	0.459 / -164.677	5.348 / 78.762	0.087 / 54.098	0.279 / -101.861
1.000GHz	0.459 / -174.570	4.315 / 71.431	0.101 / 55.498	0.273 / -110.245
1.200GHz	0.461 / 177.870	3.624 / 65.549	0.117 / 58.181	0.280 / -113.766
1.400GHz	0.470 / 170.614	3.133 / 59.011	0.133 / 59.002	0.293 / -121.839
1.600GHz	0.480 / 164.637	2.757 / 53.722	0.151 / 59.298	0.305 / -127.311
1.800GHz	0.490 / 159.080	2.470 / 48.339	0.169 / 58.336	0.323 / -130.964
2.000GHz	0.504 / 154.302	2.228 / 43.463	0.187 / 57.893	0.343 / -136.001
2.200GHz	0.515 / 148.888	2.039 / 38.506	0.206 / 56.544	0.360 / -141.355
2.400GHz	0.524 / 144.454	1.870 / 34.200	0.226 / 55.344	0.382 / -145.863
2.600GHz	0.540 / 139.868	1.737 / 29.435	0.244 / 53.624	0.404 / -151.178
2.800GHz	0.550 / 134.110	1.609 / 25.062	0.265 / 51.986	0.428 / -152.701
3.000GHz	0.557 / 129.455	1.504 / 21.416	0.281 / 49.802	0.457 / -157.936

**V<sub>CE</sub> = 3V, I<sub>CC</sub> = 15mA**

freq	S(1,1)	S(2,1)	S(1,2)	S(2,2)
400.0MHz	0.457 / -143.864	10.763 / 94.877	0.056 / 52.840	0.309 / -90.025
600.0MHz	0.450 / -160.675	7.407 / 84.972	0.072 / 57.561	0.261 / -102.139
800.0MHz	0.450 / -172.089	5.648 / 77.279	0.086 / 58.622	0.238 / -110.428
1.000GHz	0.455 / 179.229	4.543 / 70.572	0.104 / 59.409	0.238 / -119.619
1.200GHz	0.457 / 172.555	3.815 / 65.126	0.120 / 62.677	0.247 / -121.459
1.400GHz	0.464 / 166.085	3.297 / 58.952	0.140 / 61.046	0.266 / -129.382
1.600GHz	0.475 / 160.738	2.900 / 53.980	0.157 / 60.538	0.277 / -133.493
1.800GHz	0.484 / 155.274	2.599 / 48.822	0.175 / 59.746	0.296 / -136.613
2.000GHz	0.498 / 151.051	2.345 / 44.201	0.195 / 58.344	0.314 / -141.273
2.200GHz	0.509 / 145.763	2.150 / 39.453	0.213 / 56.759	0.335 / -145.798
2.400GHz	0.518 / 141.657	1.972 / 35.219	0.234 / 55.180	0.355 / -150.183
2.600GHz	0.532 / 137.359	1.834 / 30.634	0.252 / 53.317	0.377 / -155.051
2.800GHz	0.539 / 131.839	1.702 / 26.305	0.270 / 51.445	0.398 / -155.911
3.000GHz	0.548 / 127.407	1.594 / 22.787	0.289 / 49.058	0.428 / -160.790

V<sub>CE</sub> = 3V, I<sub>CC</sub> = 20mA

freq	S(1,1)	S(2,1)	S(1,2)	S(2,2)
400.0MHz	0.443 / -151.627	11.094 / 92.666	0.051 / 57.096	0.268 / -95.518
600.0MHz	0.446 / -166.399	7.595 / 83.555	0.069 / 60.370	0.235 / -107.809
800.0MHz	0.451 / -176.508	5.779 / 76.341	0.087 / 63.139	0.219 / -116.167
1.000GHz	0.455 / 175.854	4.642 / 69.948	0.105 / 64.020	0.223 / -125.295
1.200GHz	0.457 / 169.542	3.899 / 64.752	0.123 / 63.650	0.232 / -126.388
1.400GHz	0.468 / 163.338	3.367 / 58.803	0.143 / 62.762	0.250 / -133.833
1.600GHz	0.478 / 158.313	2.962 / 53.979	0.161 / 62.049	0.264 / -137.425
1.800GHz	0.486 / 153.251	2.654 / 48.961	0.181 / 60.463	0.283 / -140.012
2.000GHz	0.497 / 149.094	2.396 / 44.448	0.199 / 58.916	0.301 / -144.647
2.200GHz	0.511 / 144.034	2.197 / 39.748	0.217 / 57.239	0.321 / -148.938
2.400GHz	0.518 / 139.969	2.016 / 35.656	0.237 / 55.494	0.342 / -152.735
2.600GHz	0.533 / 136.025	1.875 / 31.126	0.257 / 53.154	0.365 / -157.310
2.800GHz	0.542 / 130.423	1.740 / 26.903	0.275 / 50.863	0.385 / -157.623
3.000GHz	0.548 / 126.076	1.632 / 23.498	0.294 / 49.074	0.415 / -162.833

V<sub>CE</sub> = 3V, I<sub>CC</sub> = 25mA

freq	S(1,1)	S(2,1)	S(1,2)	S(2,2)
400.0MHz	0.441 / -156.587	11.211 / 91.193	0.049 / 61.572	0.247 / -100.342
600.0MHz	0.448 / -170.345	7.647 / 82.577	0.067 / 63.159	0.216 / -111.761
800.0MHz	0.454 / -179.290	5.812 / 75.641	0.087 / 64.772	0.205 / -119.410
1.000GHz	0.461 / 173.579	4.665 / 69.420	0.106 / 66.203	0.213 / -128.166
1.200GHz	0.462 / 167.184	3.919 / 64.372	0.125 / 64.000	0.223 / -128.854
1.400GHz	0.472 / 161.220	3.383 / 58.517	0.144 / 64.286	0.244 / -135.882
1.600GHz	0.484 / 156.644	2.976 / 53.774	0.164 / 62.616	0.259 / -139.515
1.800GHz	0.492 / 151.586	2.667 / 48.816	0.183 / 61.190	0.276 / -142.023
2.000GHz	0.503 / 147.864	2.408 / 44.328	0.202 / 59.000	0.294 / -146.084
2.200GHz	0.514 / 142.927	2.207 / 39.695	0.221 / 57.139	0.314 / -150.402
2.400GHz	0.523 / 138.932	2.027 / 35.635	0.240 / 55.370	0.335 / -154.115
2.600GHz	0.536 / 135.003	1.883 / 31.127	0.260 / 53.130	0.358 / -158.456
2.800GHz	0.546 / 129.366	1.750 / 26.994	0.277 / 51.175	0.378 / -158.948
3.000GHz	0.550 / 125.160	1.641 / 23.527	0.296 / 48.748	0.408 / -163.880

V<sub>CE</sub> = 3V, I<sub>CC</sub> = 30mA

freq	S(1,1)	S(2,1)	S(1,2)	S(2,2)
400.0MHz	0.450 / -161.058	11.155 / 90.003	0.050 / 61.082	0.224 / -103.425
600.0MHz	0.455 / -173.438	7.595 / 81.705	0.066 / 65.309	0.203 / -114.073
800.0MHz	0.461 / 178.359	5.770 / 74.924	0.086 / 66.355	0.198 / -121.814
1.000GHz	0.467 / 171.557	4.630 / 68.853	0.106 / 66.465	0.205 / -130.277
1.200GHz	0.470 / 165.861	3.888 / 63.827	0.124 / 66.819	0.218 / -129.816
1.400GHz	0.480 / 160.230	3.355 / 58.021	0.146 / 65.371	0.240 / -136.905
1.600GHz	0.492 / 155.411	2.950 / 53.293	0.164 / 63.630	0.254 / -140.521
1.800GHz	0.500 / 150.705	2.644 / 48.374	0.184 / 61.439	0.274 / -142.896
2.000GHz	0.513 / 146.799	2.387 / 43.916	0.204 / 59.512	0.291 / -146.924
2.200GHz	0.523 / 141.832	2.188 / 39.308	0.224 / 57.805	0.313 / -151.119
2.400GHz	0.530 / 138.189	2.009 / 35.269	0.243 / 55.917	0.334 / -154.667
2.600GHz	0.544 / 134.038	1.869 / 30.749	0.262 / 53.494	0.356 / -159.331
2.800GHz	0.552 / 128.737	1.734 / 26.548	0.282 / 51.051	0.376 / -159.288
3.000GHz	0.559 / 124.653	1.628 / 23.197	0.299 / 48.932	0.406 / -164.152

V<sub>CE</sub> = 6V, I<sub>CC</sub> = 5mA

freq	S(1,1)	S(2,1)	S(1,2)	S(2,2)
400.0MHz	0.584 / -105.075	8.147 / 108.031	0.079 / 43.298	0.554 / -64.699
600.0MHz	0.525 / -128.648	5.907 / 93.728	0.090 / 38.912	0.452 / -77.605
800.0MHz	0.495 / -145.602	4.602 / 83.059	0.096 / 40.537	0.399 / -86.590
1.000GHz	0.484 / -158.406	3.747 / 74.141	0.103 / 44.831	0.375 / -95.746
1.200GHz	0.480 / -168.174	3.159 / 67.087	0.110 / 46.551	0.376 / -100.424
1.400GHz	0.487 / -177.058	2.735 / 59.615	0.125 / 49.200	0.381 / -109.211
1.600GHz	0.497 / 175.757	2.406 / 53.580	0.134 / 52.964	0.391 / -115.428
1.800GHz	0.505 / 168.565	2.152 / 47.548	0.148 / 54.362	0.406 / -120.582
2.000GHz	0.518 / 162.863	1.939 / 42.106	0.165 / 55.603	0.423 / -126.556
2.200GHz	0.531 / 156.643	1.772 / 36.735	0.183 / 55.667	0.442 / -132.646
2.400GHz	0.543 / 151.353	1.621 / 32.126	0.202 / 56.032	0.463 / -138.154
2.600GHz	0.559 / 146.064	1.501 / 27.080	0.225 / 55.144	0.484 / -144.276
2.800GHz	0.569 / 139.544	1.386 / 22.598	0.245 / 53.850	0.507 / -147.189
3.000GHz	0.577 / 134.805	1.289 / 18.936	0.265 / 52.408	0.534 / -153.141

V<sub>CE</sub> = 6V, I<sub>CC</sub> = 10mA

freq	S(1,1)	S(2,1)	S(1,2)	S(2,2)
400.0MHz	0.484 / -128.129	10.199 / 99.649	0.059 / 48.175	0.395 / -79.244
600.0MHz	0.458 / -148.684	7.124 / 88.199	0.075 / 50.721	0.322 / -91.926
800.0MHz	0.449 / -162.384	5.459 / 79.547	0.086 / 54.260	0.286 / -101.010
1.000GHz	0.448 / -172.733	4.406 / 72.194	0.101 / 56.618	0.279 / -109.994
1.200GHz	0.450 / 179.728	3.703 / 66.272	0.115 / 57.771	0.283 / -113.079
1.400GHz	0.456 / 171.900	3.202 / 59.779	0.132 / 58.551	0.296 / -121.351
1.600GHz	0.468 / 166.049	2.818 / 54.541	0.149 / 58.194	0.305 / -126.237
1.800GHz	0.477 / 160.067	2.524 / 49.099	0.167 / 57.941	0.324 / -130.058
2.000GHz	0.491 / 155.255	2.276 / 44.265	0.185 / 57.161	0.341 / -135.309
2.200GHz	0.502 / 149.723	2.085 / 39.286	0.204 / 56.386	0.360 / -140.569
2.400GHz	0.513 / 145.239	1.912 / 34.967	0.223 / 55.214	0.381 / -145.225
2.600GHz	0.529 / 140.794	1.773 / 30.181	0.244 / 53.669	0.403 / -150.523
2.800GHz	0.537 / 134.687	1.646 / 25.831	0.262 / 51.834	0.426 / -152.214
3.000GHz	0.543 / 130.299	1.539 / 22.248	0.281 / 49.856	0.454 / -157.446

V<sub>CE</sub> = 6V, I<sub>CC</sub> = 15mA

freq	S(1,1)	S(2,1)	S(1,2)	S(2,2)
400.0MHz	0.448 / -140.431	11.027 / 95.848	0.055 / 53.910	0.324 / -88.628
600.0MHz	0.436 / -158.389	7.605 / 85.804	0.070 / 57.644	0.271 / -100.251
800.0MHz	0.437 / -169.928	5.802 / 78.069	0.087 / 58.939	0.244 / -109.205
1.000GHz	0.439 / -178.735	4.672 / 71.353	0.104 / 60.665	0.243 / -118.670
1.200GHz	0.440 / 173.963	3.923 / 65.912	0.120 / 61.868	0.251 / -120.834
1.400GHz	0.451 / 167.177	3.388 / 59.808	0.138 / 61.751	0.265 / -128.613
1.600GHz	0.461 / 161.679	2.984 / 54.878	0.156 / 59.972	0.278 / -133.018
1.800GHz	0.470 / 156.178	2.672 / 49.730	0.175 / 59.465	0.296 / -136.060
2.000GHz	0.482 / 151.806	2.413 / 45.121	0.193 / 57.991	0.311 / -140.801
2.200GHz	0.494 / 146.554	2.212 / 40.362	0.213 / 56.325	0.330 / -145.617
2.400GHz	0.503 / 142.591	2.028 / 36.165	0.230 / 55.017	0.352 / -149.609
2.600GHz	0.517 / 138.177	1.886 / 31.584	0.249 / 53.126	0.374 / -154.480
2.800GHz	0.527 / 132.409	1.750 / 27.340	0.269 / 51.386	0.394 / -155.327
3.000GHz	0.534 / 128.081	1.640 / 23.881	0.286 / 49.425	0.423 / -160.384

V<sub>CE</sub> = 6V, I<sub>CC</sub> = 20mA

freq	S(1,1)	S(2,1)	S(1,2)	S(2,2)
400.0MHz	0.435 / -148.375	11.434 / 93.739	0.052 / 57.018	0.283 / -94.267
600.0MHz	0.428 / -163.826	7.843 / 84.468	0.070 / 59.803	0.244 / -106.390
800.0MHz	0.433 / -174.378	5.971 / 77.215	0.088 / 63.801	0.224 / -115.198
1.000GHz	0.437 / 177.307	4.802 / 70.858	0.106 / 64.222	0.226 / -123.723
1.200GHz	0.440 / 170.600	4.030 / 65.672	0.123 / 63.687	0.234 / -125.248
1.400GHz	0.448 / 164.771	3.482 / 59.726	0.140 / 62.517	0.253 / -132.832
1.600GHz	0.460 / 159.258	3.065 / 54.993	0.160 / 61.159	0.263 / -136.725
1.800GHz	0.467 / 154.029	2.746 / 49.978	0.180 / 60.043	0.281 / -139.651
2.000GHz	0.479 / 149.765	2.480 / 45.494	0.198 / 58.667	0.298 / -143.866
2.200GHz	0.492 / 144.741	2.273 / 40.850	0.217 / 56.867	0.317 / -148.580
2.400GHz	0.500 / 140.793	2.087 / 36.789	0.237 / 55.167	0.337 / -152.230
2.600GHz	0.512 / 136.698	1.940 / 32.208	0.255 / 53.092	0.359 / -156.696
2.800GHz	0.523 / 131.299	1.803 / 28.003	0.273 / 50.734	0.378 / -157.288
3.000GHz	0.530 / 126.694	1.689 / 24.579	0.290 / 48.655	0.407 / -162.249

V<sub>CE</sub> = 6V, I<sub>CC</sub> = 25mA

freq	S(1,1)	S(2,1)	S(1,2)	S(2,2)
400.0MHz	0.424 / -152.995	11.650 / 92.373	0.049 / 60.411	0.265 / -98.864
600.0MHz	0.426 / -167.503	7.963 / 83.649	0.068 / 62.815	0.225 / -109.762
800.0MHz	0.432 / -177.284	6.057 / 76.668	0.087 / 63.669	0.212 / -118.788
1.000GHz	0.437 / 175.123	4.866 / 70.508	0.106 / 65.483	0.216 / -127.075
1.200GHz	0.438 / 168.693	4.087 / 65.452	0.123 / 64.512	0.226 / -128.344
1.400GHz	0.448 / 162.832	3.527 / 59.635	0.144 / 63.814	0.244 / -135.269
1.600GHz	0.460 / 157.650	3.104 / 54.971	0.164 / 61.859	0.257 / -138.969
1.800GHz	0.469 / 152.729	2.783 / 50.052	0.182 / 60.773	0.275 / -141.893
2.000GHz	0.480 / 148.631	2.512 / 45.630	0.200 / 58.806	0.290 / -146.042
2.200GHz	0.491 / 143.675	2.304 / 41.016	0.220 / 56.944	0.310 / -150.091
2.400GHz	0.499 / 139.822	2.115 / 37.009	0.238 / 55.000	0.330 / -153.872
2.600GHz	0.514 / 135.498	1.968 / 32.513	0.259 / 53.021	0.350 / -158.209
2.800GHz	0.524 / 130.208	1.828 / 28.311	0.275 / 50.714	0.370 / -158.697
3.000GHz	0.529 / 125.835	1.715 / 24.929	0.291 / 48.466	0.399 / -163.195



V<sub>CE</sub> = 6V, I<sub>CC</sub> = 30mA

freq	S(1,1)	S(2,1)	S(1,2)	S(2,2)
400.0MHz	0.421 / -156.682	11.763 / 91.439	0.048 / 64.883	0.246 / -101.370
600.0MHz	0.427 / -170.180	8.026 / 83.016	0.070 / 64.603	0.214 / -112.828
800.0MHz	0.432 / -179.228	6.099 / 76.231	0.087 / 66.352	0.206 / -120.980
1.000GHz	0.437 / 173.532	4.899 / 70.181	0.106 / 65.850	0.212 / -129.300
1.200GHz	0.441 / 167.394	4.113 / 65.255	0.126 / 65.811	0.220 / -129.986
1.400GHz	0.450 / 161.533	3.551 / 59.503	0.145 / 63.904	0.240 / -136.730
1.600GHz	0.461 / 156.749	3.126 / 54.851	0.164 / 61.966	0.253 / -140.468
1.800GHz	0.470 / 151.705	2.801 / 50.015	0.184 / 60.899	0.268 / -143.137
2.000GHz	0.482 / 147.724	2.530 / 45.644	0.201 / 59.201	0.287 / -146.812
2.200GHz	0.493 / 142.776	2.318 / 41.097	0.222 / 57.112	0.305 / -151.264
2.400GHz	0.501 / 139.063	2.129 / 37.101	0.242 / 55.366	0.326 / -154.761
2.600GHz	0.514 / 134.989	1.982 / 32.641	0.260 / 53.237	0.348 / -159.167
2.800GHz	0.524 / 129.462	1.842 / 28.455	0.278 / 51.022	0.364 / -159.315
3.000GHz	0.530 / 125.297	1.728 / 25.111	0.294 / 48.601	0.395 / -163.945

V<sub>CE</sub> = 8V, I<sub>CC</sub> = 3mA

freq	S(1,1)	S(2,1)	S(1,2)	S(2,2)
400.0MHz	0.673 / -88.966	6.488 / 114.927	0.096 / 42.239	0.667 / -55.457
600.0MHz	0.596 / -113.638	4.902 / 98.721	0.105 / 36.029	0.566 / -68.579
800.0MHz	0.550 / -131.873	3.891 / 86.410	0.109 / 33.079	0.499 / -78.497
1.000GHz	0.527 / -146.478	3.204 / 76.266	0.110 / 33.218	0.467 / -87.422
1.200GHz	0.517 / -157.284	2.710 / 68.186	0.113 / 35.593	0.460 / -93.585
1.400GHz	0.520 / -167.659	2.358 / 59.850	0.117 / 40.147	0.463 / -102.425
1.600GHz	0.526 / -175.958	2.076 / 53.153	0.122 / 45.549	0.467 / -109.046
1.800GHz	0.537 / 176.060	1.858 / 46.581	0.133 / 49.168	0.481 / -115.067
2.000GHz	0.549 / 169.482	1.670 / 40.764	0.146 / 52.678	0.499 / -121.599
2.200GHz	0.560 / 162.421	1.523 / 35.107	0.165 / 54.804	0.514 / -128.361
2.400GHz	0.573 / 156.431	1.391 / 30.308	0.185 / 56.651	0.532 / -134.382
2.600GHz	0.588 / 150.764	1.281 / 25.128	0.206 / 56.582	0.553 / -141.198
2.800GHz	0.600 / 143.749	1.179 / 20.624	0.230 / 55.688	0.572 / -144.613
3.000GHz	0.607 / 138.133	1.094 / 17.198	0.252 / 54.440	0.600 / -150.958

V<sub>CE</sub> = 8V, I<sub>CC</sub> = 5mA

freq	S(1,1)	S(2,1)	S(1,2)	S(2,2)
400.0MHz	0.587 / -104.383	8.268 / 108.169	0.079 / 41.010	0.546 / -64.715
600.0MHz	0.523 / -128.558	5.994 / 93.909	0.090 / 38.684	0.448 / -77.605
800.0MHz	0.493 / -145.158	4.670 / 83.299	0.095 / 40.644	0.395 / -86.835
1.000GHz	0.481 / -158.010	3.801 / 74.428	0.103 / 43.416	0.375 / -95.834
1.200GHz	0.476 / -167.656	3.205 / 67.401	0.111 / 46.814	0.372 / -100.271
1.400GHz	0.482 / -176.935	2.778 / 59.940	0.124 / 49.424	0.377 / -109.142
1.600GHz	0.493 / 175.887	2.443 / 53.960	0.133 / 51.806	0.386 / -115.128
1.800GHz	0.501 / 168.820	2.188 / 47.913	0.150 / 54.189	0.402 / -120.486
2.000GHz	0.515 / 163.091	1.971 / 42.530	0.165 / 55.212	0.417 / -126.445
2.200GHz	0.527 / 156.753	1.801 / 37.168	0.183 / 55.606	0.436 / -132.466
2.400GHz	0.539 / 151.629	1.649 / 32.558	0.203 / 55.748	0.456 / -137.746
2.600GHz	0.555 / 146.498	1.523 / 27.499	0.224 / 54.896	0.477 / -144.079
2.800GHz	0.565 / 140.049	1.408 / 22.884	0.242 / 53.545	0.501 / -146.776
3.000GHz	0.572 / 134.882	1.312 / 19.321	0.264 / 52.174	0.527 / -152.562

V<sub>CE</sub> = 8V, I<sub>CC</sub> = 10mA

freq	S(1,1)	S(2,1)	S(1,2)	S(2,2)
400.0MHz	0.487 / -127.356	10.294 / 99.888	0.062 / 52.361	0.399 / -79.072
600.0MHz	0.455 / -148.065	7.196 / 88.392	0.077 / 51.185	0.323 / -92.252
800.0MHz	0.445 / -161.946	5.520 / 79.807	0.087 / 53.391	0.288 / -100.818
1.000GHz	0.443 / -172.275	4.456 / 72.461	0.101 / 54.514	0.278 / -109.767
1.200GHz	0.444 / 179.756	3.745 / 66.567	0.116 / 58.511	0.281 / -112.788
1.400GHz	0.452 / 172.294	3.239 / 60.064	0.134 / 58.350	0.293 / -121.242
1.600GHz	0.463 / 166.104	2.851 / 54.847	0.149 / 57.998	0.302 / -126.016
1.800GHz	0.473 / 160.132	2.553 / 49.446	0.167 / 58.028	0.320 / -130.036
2.000GHz	0.485 / 155.505	2.304 / 44.606	0.183 / 57.305	0.338 / -135.183
2.200GHz	0.496 / 149.819	2.110 / 39.629	0.202 / 56.310	0.355 / -140.406
2.400GHz	0.507 / 145.453	1.934 / 35.355	0.222 / 55.080	0.377 / -144.953
2.600GHz	0.523 / 141.058	1.796 / 30.589	0.239 / 53.724	0.398 / -150.373
2.800GHz	0.533 / 135.234	1.666 / 26.235	0.259 / 51.708	0.420 / -151.735
3.000GHz	0.539 / 130.357	1.558 / 22.611	0.278 / 49.919	0.448 / -157.017

V<sub>CE</sub> = 8V, I<sub>CC</sub> = 15mA

freq	S(1,1)	S(2,1)	S(1,2)	S(2,2)
400.0MHz	0.448 / -138.632	11.066 / 96.402	0.057 / 55.248	0.332 / -87.507
600.0MHz	0.435 / -156.751	7.644 / 86.220	0.071 / 57.290	0.275 / -99.732
800.0MHz	0.434 / -169.026	5.836 / 78.414	0.089 / 58.168	0.249 / -108.653
1.000GHz	0.433 / -177.810	4.699 / 71.641	0.104 / 60.383	0.243 / -117.329
1.200GHz	0.435 / 174.780	3.949 / 66.173	0.120 / 60.926	0.251 / -119.675
1.400GHz	0.446 / 167.826	3.411 / 60.075	0.138 / 60.617	0.266 / -127.718
1.600GHz	0.456 / 162.162	3.002 / 55.105	0.156 / 60.099	0.279 / -132.138
1.800GHz	0.465 / 156.661	2.691 / 49.975	0.174 / 59.047	0.296 / -135.428
2.000GHz	0.478 / 152.143	2.429 / 45.363	0.193 / 57.902	0.310 / -140.124
2.200GHz	0.489 / 146.938	2.227 / 40.607	0.211 / 56.374	0.330 / -144.828
2.400GHz	0.500 / 142.769	2.042 / 36.460	0.230 / 54.908	0.350 / -148.862
2.600GHz	0.512 / 138.517	1.899 / 31.807	0.248 / 53.412	0.372 / -153.815
2.800GHz	0.522 / 132.686	1.763 / 27.522	0.269 / 51.013	0.390 / -154.929
3.000GHz	0.528 / 128.194	1.651 / 24.071	0.286 / 48.900	0.421 / -159.921

V<sub>CE</sub> = 8V, I<sub>CC</sub> = 20mA

freq	S(1,1)	S(2,1)	S(1,2)	S(2,2)
400.0MHz	0.430 / -147.021	11.508 / 94.168	0.055 / 58.583	0.294 / -93.407
600.0MHz	0.425 / -162.893	7.900 / 84.828	0.073 / 61.326	0.248 / -105.520
800.0MHz	0.428 / -173.516	6.017 / 77.526	0.089 / 62.785	0.226 / -114.372
1.000GHz	0.432 / 178.041	4.837 / 71.117	0.104 / 62.201	0.228 / -123.576
1.200GHz	0.434 / 171.260	4.061 / 65.916	0.124 / 63.765	0.237 / -124.786
1.400GHz	0.443 / 164.956	3.511 / 60.000	0.141 / 62.553	0.252 / -132.071
1.600GHz	0.453 / 159.738	3.089 / 55.258	0.159 / 60.916	0.263 / -136.403
1.800GHz	0.463 / 154.311	2.770 / 50.254	0.179 / 59.841	0.279 / -138.592
2.000GHz	0.476 / 150.158	2.500 / 45.780	0.197 / 58.495	0.297 / -143.196
2.200GHz	0.486 / 144.964	2.292 / 41.167	0.216 / 56.496	0.315 / -148.038
2.400GHz	0.494 / 141.120	2.104 / 37.072	0.235 / 54.894	0.334 / -151.841
2.600GHz	0.508 / 136.954	1.958 / 32.486	0.254 / 53.022	0.357 / -156.330
2.800GHz	0.518 / 131.166	1.818 / 28.299	0.272 / 50.824	0.376 / -156.889
3.000GHz	0.523 / 126.816	1.706 / 24.851	0.287 / 48.868	0.406 / -161.698

V<sub>CE</sub> = 8V, I<sub>CC</sub> = 25mA

freq	S(1,1)	S(2,1)	S(1,2)	S(2,2)
400.0MHz	0.423 / -151.150	11.721 / 92.863	0.054 / 64.728	0.269 / -97.125
600.0MHz	0.421 / -166.628	8.024 / 83.980	0.069 / 63.276	0.233 / -108.723
800.0MHz	0.427 / -176.501	6.104 / 76.967	0.086 / 63.817	0.214 / -117.530
1.000GHz	0.432 / 175.834	4.905 / 70.766	0.106 / 64.543	0.217 / -126.252
1.200GHz	0.432 / 169.194	4.120 / 65.701	0.125 / 64.213	0.225 / -127.178
1.400GHz	0.444 / 163.190	3.557 / 59.885	0.144 / 63.037	0.243 / -134.788
1.600GHz	0.454 / 158.111	3.131 / 55.231	0.162 / 61.687	0.257 / -138.421
1.800GHz	0.462 / 153.184	2.808 / 50.324	0.181 / 60.660	0.273 / -141.027
2.000GHz	0.474 / 148.929	2.534 / 45.924	0.201 / 58.584	0.290 / -145.149
2.200GHz	0.485 / 143.958	2.324 / 41.346	0.219 / 56.867	0.306 / -149.515
2.400GHz	0.494 / 140.118	2.133 / 37.324	0.237 / 54.983	0.328 / -153.313
2.600GHz	0.508 / 135.985	1.986 / 32.750	0.256 / 53.041	0.348 / -157.957
2.800GHz	0.516 / 130.228	1.845 / 28.664	0.274 / 50.735	0.367 / -157.912
3.000GHz	0.523 / 126.127	1.733 / 25.250	0.291 / 48.498	0.398 / -162.802

V<sub>CE</sub> = 8V, I<sub>CC</sub> = 30mA

freq	S(1,1)	S(2,1)	S(1,2)	S(2,2)
400.0MHz	0.421 / -155.369	11.835 / 91.953	0.051 / 61.677	0.255 / -99.650
600.0MHz	0.420 / -169.141	8.086 / 83.398	0.068 / 63.447	0.221 / -111.126
800.0MHz	0.427 / -178.471	6.150 / 76.546	0.088 / 65.979	0.207 / -119.209
1.000GHz	0.431 / 174.110	4.939 / 70.480	0.106 / 66.256	0.211 / -128.193
1.200GHz	0.433 / 167.968	4.147 / 65.508	0.125 / 65.636	0.221 / -128.835
1.400GHz	0.444 / 162.097	3.580 / 59.776	0.144 / 64.234	0.240 / -136.506
1.600GHz	0.455 / 157.121	3.152 / 55.153	0.164 / 62.022	0.251 / -139.709
1.800GHz	0.462 / 152.087	2.826 / 50.309	0.183 / 60.777	0.268 / -141.887
2.000GHz	0.476 / 147.990	2.551 / 45.927	0.202 / 58.903	0.284 / -146.346
2.200GHz	0.487 / 143.234	2.338 / 41.379	0.220 / 56.962	0.303 / -150.476
2.400GHz	0.495 / 139.284	2.148 / 37.407	0.240 / 55.042	0.324 / -154.203
2.600GHz	0.508 / 135.299	1.999 / 32.937	0.258 / 53.054	0.345 / -158.480
2.800GHz	0.515 / 129.622	1.859 / 28.768	0.277 / 50.507	0.364 / -158.627
3.000GHz	0.523 / 125.413	1.744 / 25.362	0.293 / 48.447	0.393 / -163.494