

TISP4240LP
SYMMETRICAL TRANSIENT
VOLTAGE SUPPRESSORS

MARCH 1997 - REVISED SEPTEMBER 1997

Copyright © 1997, Power Innovations Limited, UK

TELECOMMUNICATION SYSTEM SECONDARY PROTECTION

- **Ion-Implanted Breakdown Region**
Precise and Stable Voltage
Low Voltage Overshoot under Surge

DEVICE	V _(Z) V	V _(BO) V
TISP4240LP	180	240

- **Planar Passivated Junctions**
Low Off-State Current < 10 µA
- **Rated for International Surge Wave Shapes**

WAVE SHAPE	STANDARD	I _{TSP} A
10/700 µs	CCITT IX K17	38

- **Package Options**

PACKAGE	PACKING	PART # SUFFIX
LP	Bulk	None
LP with formed leads	Tape and Reel	R

description

The TISP4240LP is designed specifically for telephone equipment protection against lightning and transients induced by a.c. power lines. These devices consist of a bidirectional suppressor element connecting the A and B terminals. They will suppress inter-wire voltage transients.

Transients are initially clipped by zener action until the voltage rises to the breakover level, which causes the device to crowbar. The high crowbar holding current prevents d.c. latchup as the transient subsides.

LP PACKAGE
(TOP VIEW)

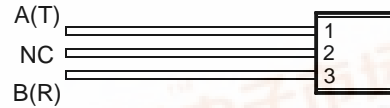

NC - No internal connection

MDTRAB

LP PACKAGE
WITH FORMED LEADS
(TOP VIEW)

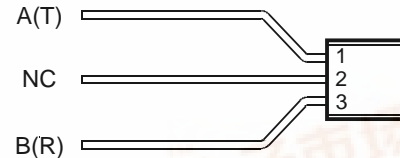

NC - No internal connection

MD4XAF

device symbol



These monolithic protection devices are fabricated in ion-implanted planar structures to ensure precise and matched breakover control and are virtually transparent to the system in normal operation.



PRODUCT INFORMATION

Information is current as of publication date. Products conform to specifications in accordance with the terms of Power Innovations standard warranty. Production processing does not necessarily include testing of all parameters.



TISP4240LP

SYMMETRICAL TRANSIENT VOLTAGE SUPPRESSORS

MARCH 1997 - REVISED SEPTEMBER 1997

absolute maximum ratings at 25°C case temperature (unless otherwise noted)

RATING	SYMBOL	VALUE	UNIT
Non-repetitive peak on-state pulse current (see Notes 1, 2 and 3) 5/310 μ s (CCITT IX K17, open-circuit voltage wave shape 1.5 kV, 10/700 μ s)	I_{TSP}	38	A
Non-repetitive peak on-state current, 50 Hz, 1 s (see Notes 1 and 2)	I_{TSM}	2.5	A rms
Initial rate of rise of on-state current, Linear current ramp, Maximum ramp value < 38 A	di_T/dt	250	A/ μ s
Junction temperature	T_J	150	°C
Operating free - air temperature range		0 to 70	°C
Storage temperature range	T_{stg}	-40 to +150	°C
Lead temperature 1.5 mm from case for 10 s	T_{lead}	260	°C

- NOTES: 1. Above 70°C, derate linearly to zero at 150°C case temperature
 2. This value applies when the initial case temperature is at (or below) 70°C. The surge may be repeated after the device has returned to thermal equilibrium.
 3. Most PTT's quote an unloaded voltage waveform. In operation the TISP essentially shorts the generator output. The resulting loaded current waveform is specified.

electrical characteristics, $T_J = 25^\circ\text{C}$

PARAMETER	TEST CONDITIONS	MIN	TYP	MAX	UNIT
V_Z Reference zener voltage	$I_Z = \pm 1\text{mA}$	± 180			V
αV_Z Temperature coefficient of reference voltage			0.1		%/°C
$V_{(BO)}$ Breakover voltage	(see Notes 4 and 5)			± 240	V
$I_{(BO)}$ Breakover current	(see Note 4)	± 0.15		± 0.6	A
V_{TM} Peak on-state voltage	$I_T = \pm 5\text{A}$ (see Notes 4 and 5)		± 2.2	± 3	V
I_H Holding current	(see Note 4)	± 150			mA
dv/dt Critical rate of rise of off-state voltage	(see Note 6)			± 5	kV/ μ s
I_D Off-state leakage current	$V_D = \pm 50\text{V}$			± 10	μ A
C_{off} Off-state capacitance	$V_D = 0$ $f = 1\text{kHz}$		70	150	pF

- NOTES: 4. These parameters must be measured using pulse techniques, $t_w = 100\ \mu\text{s}$, duty cycle $\leq 2\%$.
 5. These parameters are measured with voltage sensing contacts separate from the current carrying contacts located within 3.2 mm (0.125 inch) from the device body.
 6. Linear rate of rise, maximum voltage limited to 80 % V_Z (minimum).

thermal characteristics

PARAMETER	MIN	TYP	MAX	UNIT
$R_{\theta JA}$ Junction to free air thermal resistance			156	°C/W

PARAMETER MEASUREMENT INFORMATION

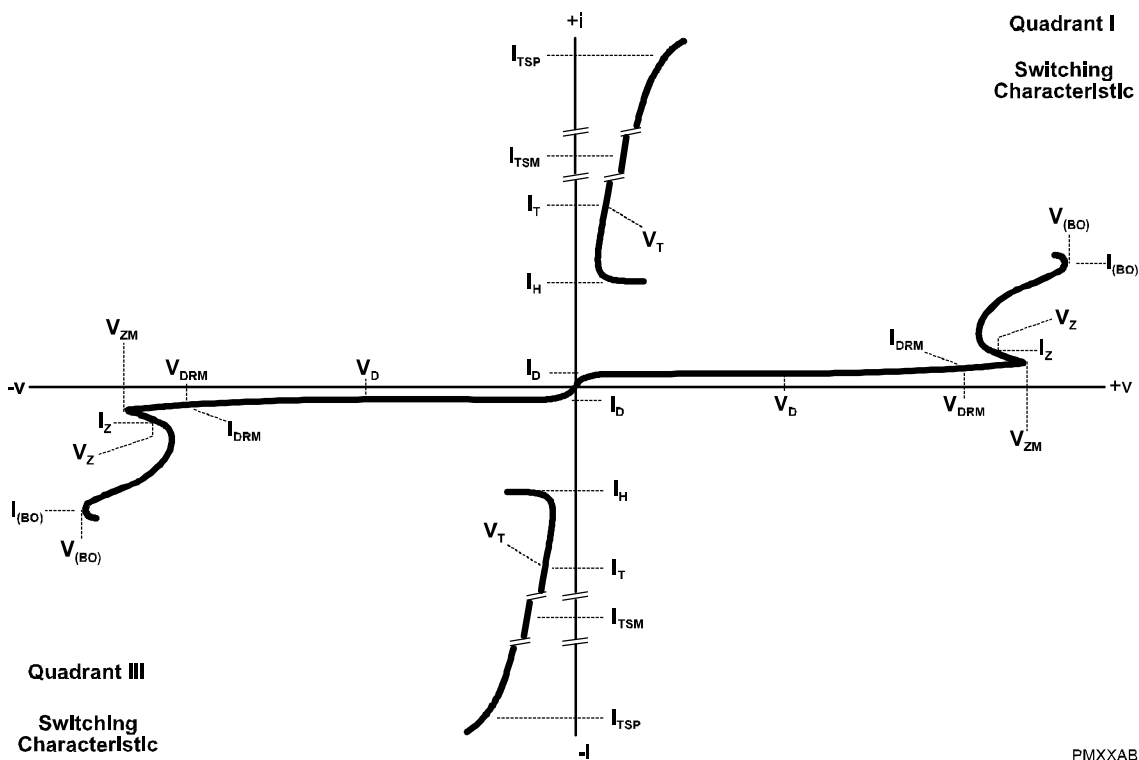

Figure 1. VOLTAGE-CURRENT CHARACTERISTICS FOR TERMINALS A AND B

PMXXAB

TISP4240LP
SYMMETRICAL TRANSIENT
VOLTAGE SUPPRESSORS

MARCH 1997 - REVISED SEPTEMBER 1997

MECHANICAL DATA

LP003 (TO-92)

3-pin cylindrical plastic package

This single-in-line package consists of a circuit mounted on a lead frame and encapsulated within a plastic compound. The compound will withstand soldering temperature with no deformation, and circuit performance characteristics will remain stable when operated in high humidity conditions. Leads require no additional cleaning or processing when used in soldered assembly.

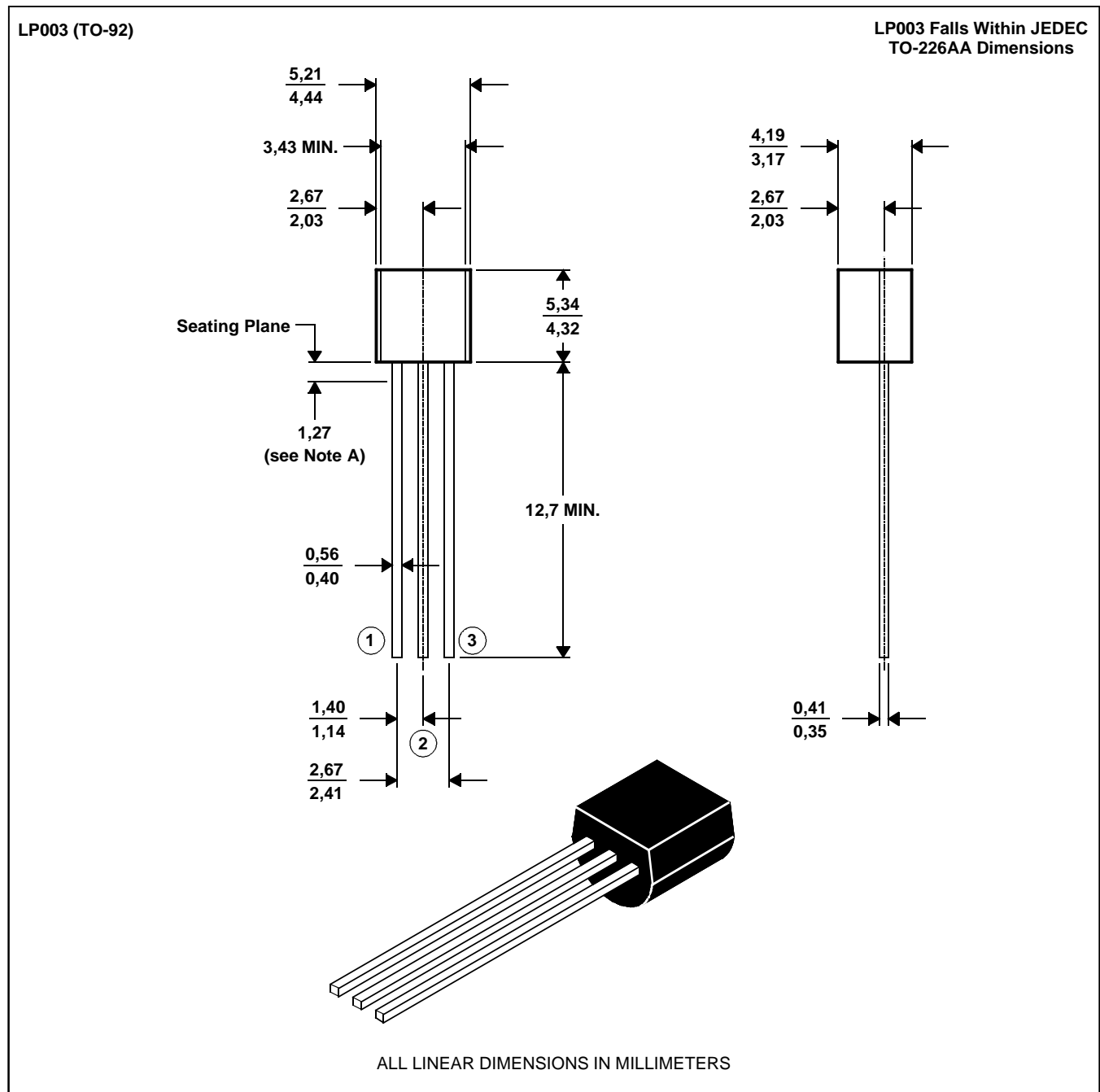

NOTE A: Lead dimensions are not controlled in this area.

MDXXAX

TISP4240LP
SYMMETRICAL TRANSIENT
VOLTAGE SUPPRESSORS
 MARCH 1997 - REVISED SEPTEMBER 1997

MECHANICAL DATA

LPR
tape dimensions

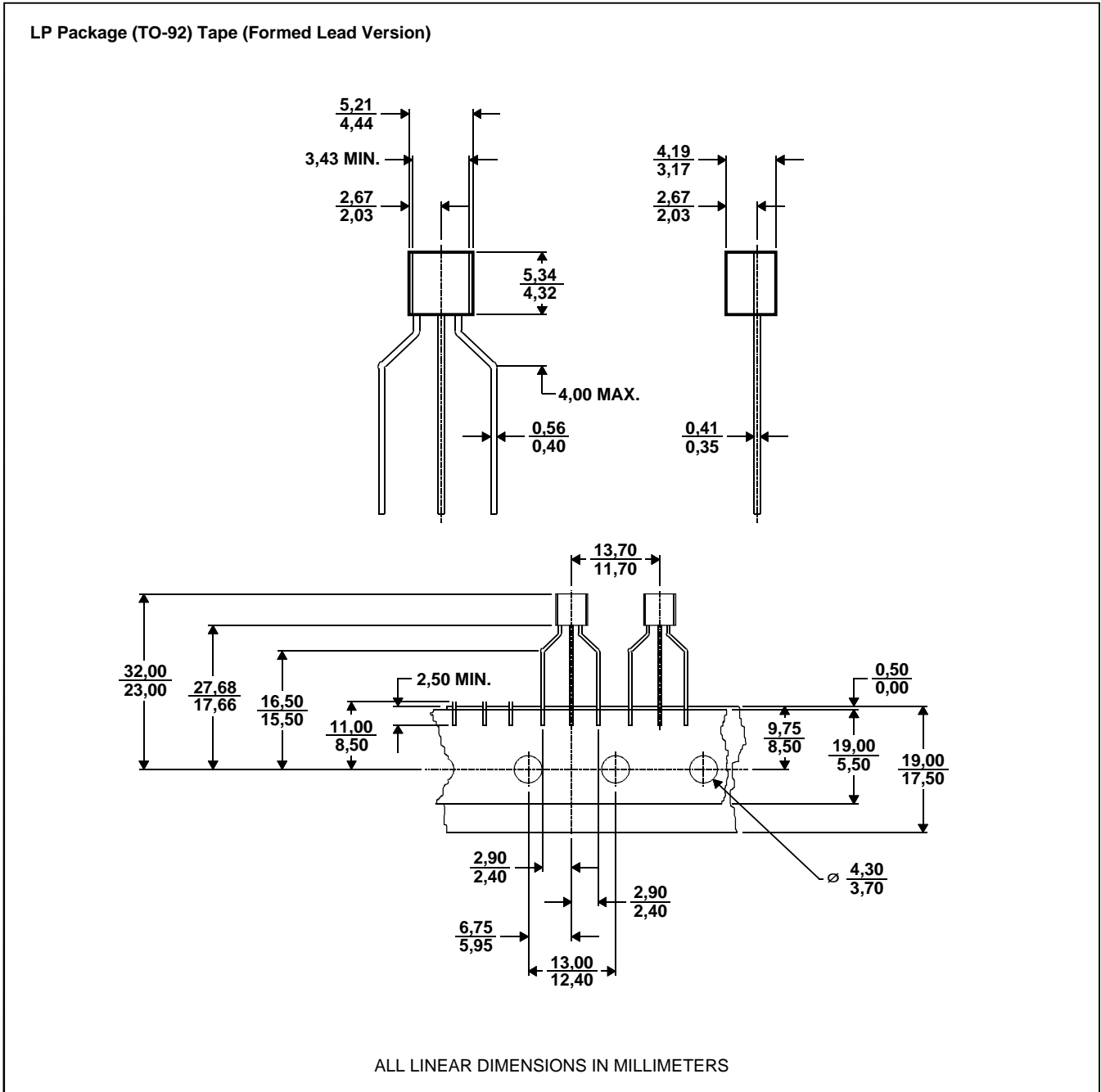

MDXXAS

IMPORTANT NOTICE

Power Innovations Limited (PI) reserves the right to make changes to its products or to discontinue any semiconductor product or service without notice, and advises its customers to verify, before placing orders, that the information being relied on is current.

PI warrants performance of its semiconductor products to the specifications applicable at the time of sale in accordance with PI's standard warranty. Testing and other quality control techniques are utilized to the extent PI deems necessary to support this warranty. Specific testing of all parameters of each device is not necessarily performed, except as mandated by government requirements.

PI accepts no liability for applications assistance, customer product design, software performance, or infringement of patents or services described herein. Nor is any license, either express or implied, granted under any patent right, copyright, design right, or other intellectual property right of PI covering or relating to any combination, machine, or process in which such semiconductor products or services might be or are used.

PI SEMICONDUCTOR PRODUCTS ARE NOT DESIGNED, INTENDED, AUTHORIZED, OR WARRANTED TO BE SUITABLE FOR USE IN LIFE-SUPPORT APPLICATIONS, DEVICES OR SYSTEMS.

Copyright © 1997, Power Innovations Limited