

Features

- 65 ms Cycle Time for Crypto Algorithm Programming
- Encryption Time < 10 ms, < 30 ms Optional
- Identification Transponder in Plastic Cube
- Contactless Read/Write Data Transmission
- High-security Crypto Algorithm Optional
- Inductive Coupled Power Supply at 125 kHz
- Basic Component R/W e5561 IDIC®
- Built-in Coil and Capacitor for Circuit Antenna
- Starts with Cyclical Data Read Out
- Self-adapting Resonance Frequency (Optional)
- 128-bit User-programmable EEPROM
- Typical < 50 ms to Write and Verify a Block
- Read/Write Protection by Lock Bits
- Options Set by EEPROM:
 - Bit Rate (Bit/s): Rf/32, Rf/64
 - Modulation: Manchester, Biphase

Application

- Car Immobilizers with Higher Security Level
- High-security Identification Systems

Description

The TK5561A-PP is a complete transponder integrating all important functions for immobilizer and identification systems. It consists of a plastic cube which accommodates the crypto IDIC e5561A and the antenna realized as tuned LC-circuit. The TK5561A-PP is a R/W crypto transponder for applications which demand higher security levels than those which standard R/W transponders can fulfil. For this reason, the TK5561A-PP has an additional encryption algorithm block which enables a base station to authenticate the transponder. Any attempt to fake the base station with a wrong transponder will be recognized immediately. For authentication, the base station transmits a challenge to the TK5561A-PP. This challenge is encrypted by both the IC and the base station. Both should possess the same secret key. Only then can the results be expected to be equal.

For detailed technical information about functions, configurations etc., please refer to the e5561 data sheet.



Read/Write Crypto Transponder for Short Cycle Time

TK5561A-PP

Figure 1. Transponder and Base Station

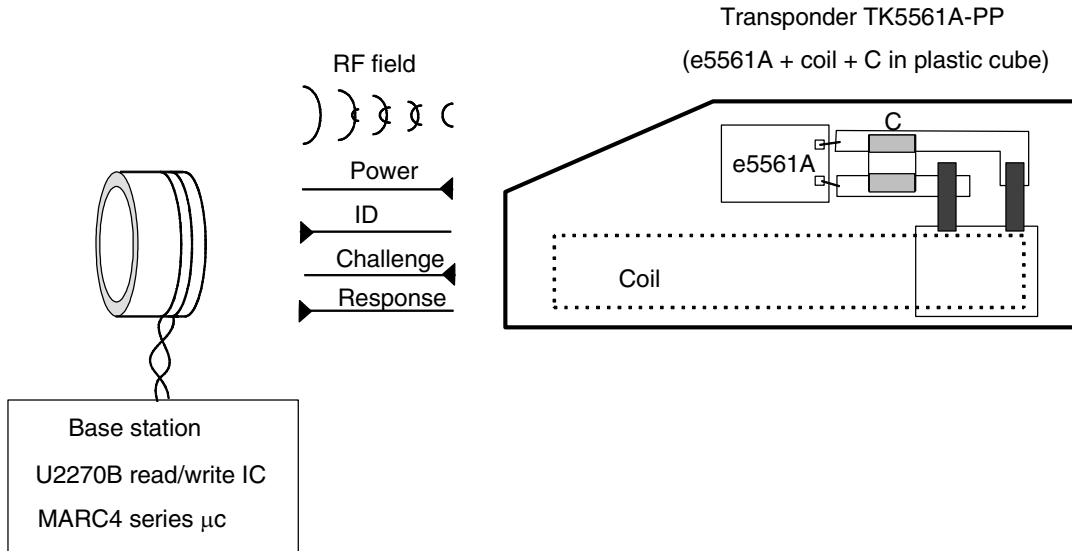
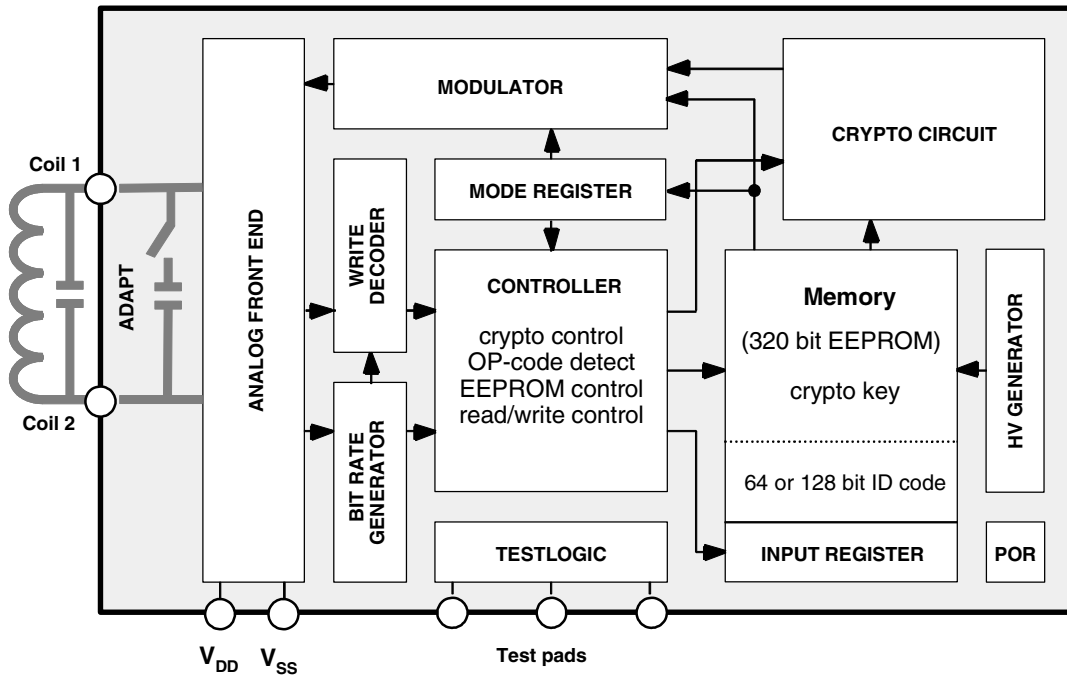

Figure 2. Block Diagram



General

The transponder is the mobile part of the closed coupled identification system (see Figure 1), whereas the read/write base station is based on the U2270B or on discrete solutions, and the read/write transponder is based on the e5561A IDIC.

The transponder is a plastic-cube device consisting of the following parts:

- The transponder antenna, with a tuned LC-circuit
- Read/write IDIC (e5561A) with EEPROM

Transponder Antenna

The antenna consists of a coil and a capacitor for tuning the circuit to the nominal carrier frequency of 125 kHz. The coil has a ferrite core to improve the read, write and programming operation distances.

Read/Write Crypto Identification

The e5561A is a member of the Atmel's contactless **IDentification IC** (IDIC) family, which are used in applications where information has to be transmitted without contacts. The IDIC is connected to a tuned LC circuit for power supply and bidirectional data communication (**Read/Write**) to a base station.

The on-chip non-volatile memory of the 320-bit EEPROM (10 blocks, 32 bits each) can be read and written blockwise by a read/write base station, e.g. based on the U2270B. Up to four blocks consisting of the user programmable ID code, the crypto key and configurations are stored in six blocks. The crypto key and the ID code can be individually protected against overwriting.

The typical operational frequency of the TK5561A-PP is 125 kHz. Two data bit rates are programmable: $R_f/32$ and $R_f/64$. During the reading operation the incoming RF field is dampened bit-wise by an on-chip load. This AM-modulation is detected by the field generating base station unit. Data transmission starts after power-up with the transmission of the ID code and continues as long as the TK5561A-PP is powered.

Writing is carried out by means of Atmel's patented writing method. To transmit data to the TK5561A-PP the read/write base station has to interrupt the RF field for a short time to create a field gap. The information is encoded in the number of clock cycles between two subsequent gaps.

See the e5561A data sheet for detailed information of the IDIC.



Absolute Maximum Ratings

Parameter	Symbol	Value	Unit
Operating temperature range	T_{amb}	-40 to +85	°C
Storage temperature range	T_{stg}	-40 to +125	°C
Maximum assembly temperature, $t < 5$ min	T_{ass}	170	°C
Magnetic field strength at 125 kHz	H_{pp}	1000	A/m

Operating Characteristics Transponder

$T_{amb} = 25^{\circ}\text{C}$, $f = 125$ kHz unless otherwise specified

Parameters	Test Conditions	Symbol	Min.	Typ.	Max.	Unit
Inductance		L		4.2		mH
LC circuit, $H_{pp} = 20$ A/m						
Resonance frequency	$T_{amb} = -40$ to $+85^{\circ}\text{C}$	f_r	121	125	129	kHz
Quality factor		Q_{LC}	5	8	11	
Magnetic Field Strength (H)						
Max. field strength where transponder does not modulate	No influence to other transponders in the field	$H_{pp\ not}$		5		A/m
Minimum Field Strength (H)						
Read mode	$T_{amb} = -40^{\circ}\text{C}$	$H_{pp\ -40}$			24	A/m
	$T_{amb} = 25^{\circ}\text{C}$	$H_{pp\ 25}$			18	A/m
	$T_{amb} = 85^{\circ}\text{C}$	$H_{pp\ 85}$			15	A/m
Programming mode	$T_{amb} = -40^{\circ}\text{C}$	$H_{pp\ -40}$			30	A/m
	$T_{amb} = 25^{\circ}\text{C}$	$H_{pp\ 25}$			35	A/m
	$T_{amb} = 85^{\circ}\text{C}$	$H_{pp\ 85}$			40	A/m
Lowest adapt frequency		f_{LA}	118	121	124.5	kHz
Highest adapt frequency		f_{HA}	125	128	131.5	kHz
Data retention EEPROM	$T = 25^{\circ}\text{C}$	$t_{retention}$	10			Years
Programming cycles EEPROM			100,000			
Programming time/block	RF = 125 kHz	t_p		16		ms
Maximum field strength		$H_{pp\ max}$			600	A/m

Figure 3. Typical Curve for Degree of Modulation

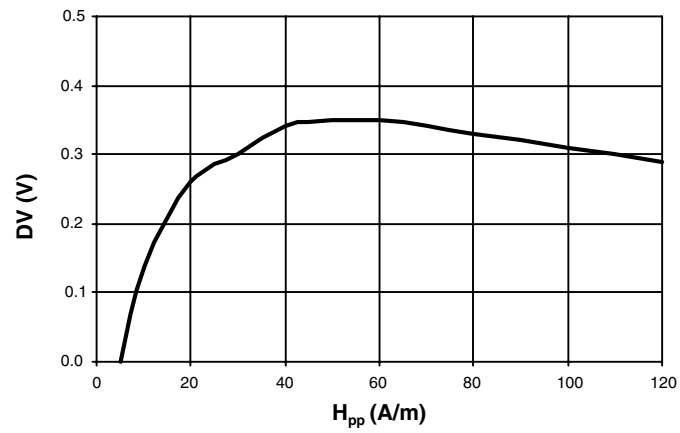
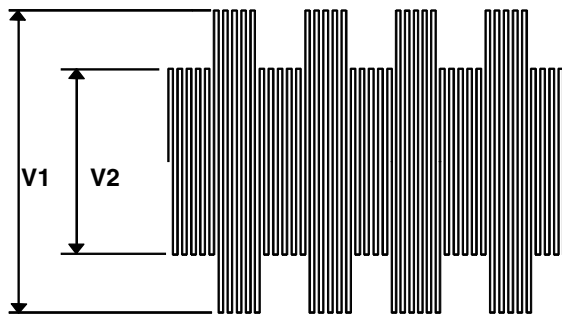

Figure 4. Measurement of the Degree of Modulation



$$m = \frac{V1 - V2}{V1 + V2}$$

Measurement Assembly

All parameters are measured in a Helmholtz-arrangement, which generates a homogeneous magnetic field (see Figure 5 and Figure 6). A function generator drives the field generating coils, so the magnetic field can be varied in frequency and field strength.

Figure 5. Testing Application

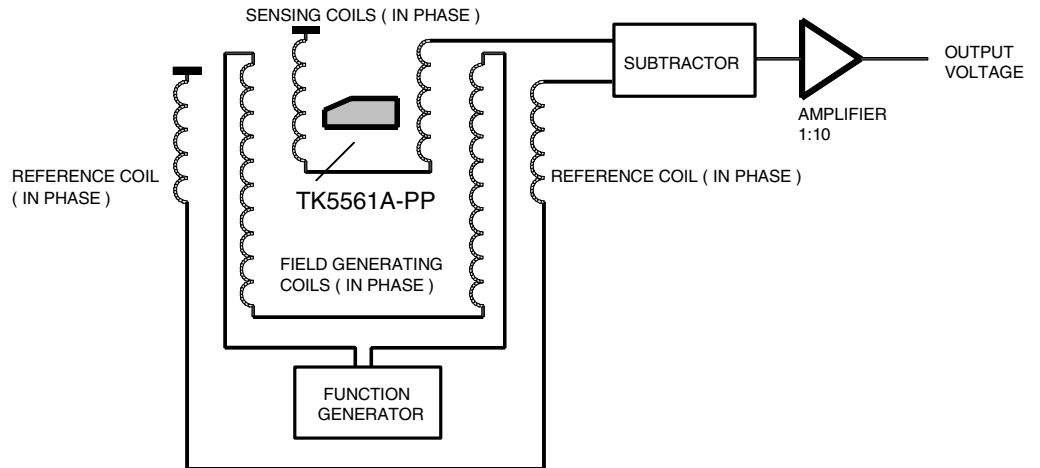
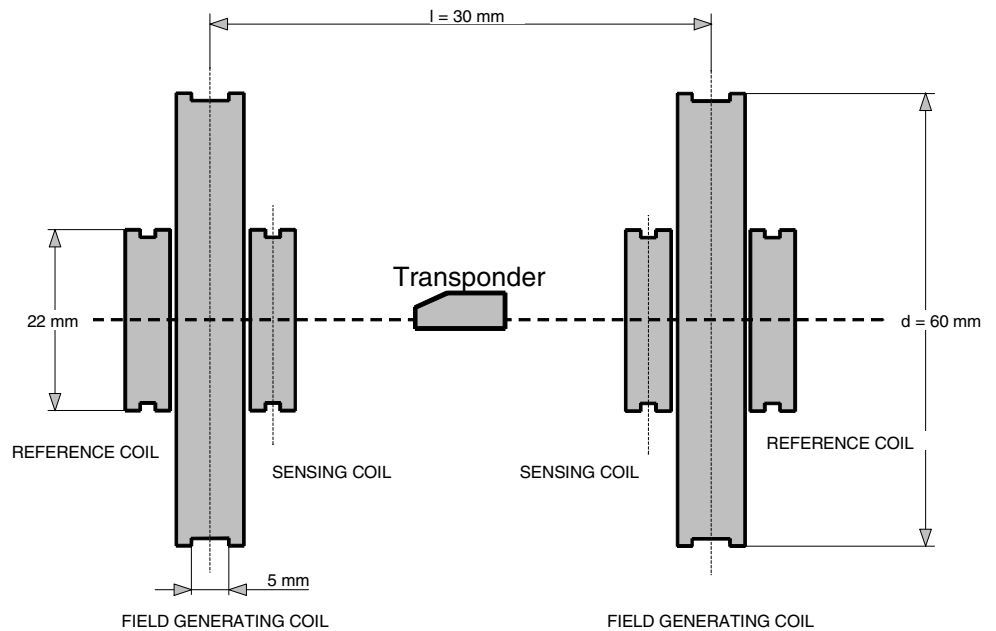

Figure 6. Testing Geometry



Writing Data into the TK5561A-PP

A write sequence of the TK5561A-PP is shown in Figure 7. Writing data into the transponder occurs by interrupting the RF field with short gaps. After the start gap the write op-code (10) is transmitted. The next 32 bits contain the actual data. The last 4 bits denote the destination block address. If the correct number of bits have been received, the actual data is programmed into the specified memory block.

Figure 7. Write Protocol to Program the EEPROM

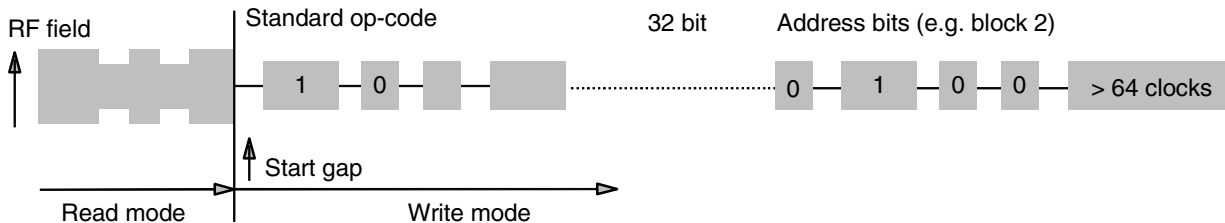

Writing Data Decoding

The time elapsing between two detected gaps is used to encode the information. As soon as a gap is detected, a counter starts counting the number of field clock cycles until the next gap is detected. Depending on how many field clocks elapse, the data is regarded as 0 or 1. The required number of field clocks is shown in Figure 8. A valid 0 is assumed if the number of counted clock periods is between 16 and 31, for a valid 1 it is 48 or 63 respectively. Any other value being detected results in an error and the device exits write mode and returns to read mode.

Figure 8. Write Data Decoding Scheme

Field clock cycles	1	16	32	48	64
Write data decoder	fail	0	fail	1	writing done

EOT

Actual Device Behavior

The TK5561A-PP detects a gap if the voltage across the coils decreases below a peak-to-peak value of about 800 mV. Until then, the clock pulses are counted. The number given for a valid 0 or 1 (see Figure 8) refers to the actual clock pulses counted by the device. However, there are always more clock pulses being counted than were applied by the base station. The reason for this is the fact that an RF field cannot be switched off immediately. The coil voltage decreases exponentially. So although the RF field coming from the base station is switched off, it takes some time until the voltage across the coils reaches the threshold peak-to-peak value of about 800 mV and the device detects the gap. Referring to the following diagram Figure 9, this means that the device uses the times t_0 internal and t_1 internal. The exact times for t_0 and t_1 are dependent on the application (e.g., field strength, etc.)

Typical time frames are:

- t_0 = 60 to 140 μ s
- t_1 = 300 to 400 μ s
- t_{gap} = 150 to 400 μ s

Antennas with a high Q-factor require longer times for t_{gap} and shorter time values for t_0 and t_1 .

Figure 9. Ideal and Actual Signal Behavior

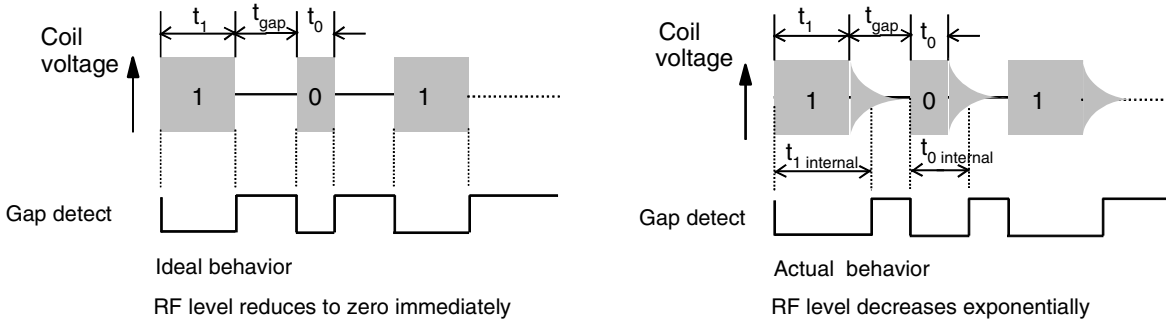

Operating Distance

The maximum distance between the base station and the TK5561A-PP depends mainly on the base station, the coil geometries and the chosen modulation options. Typical distances are 0 to 3 cm. A general maximum distance value cannot be given. A convenient way is to measure the TK5561A-PP within its environment. Rules for a correct base-station design can be provided upon request (see Antenna Design Guide).

Application

Figure 10. Complete Transponder System with the U2270B Read/Write IC

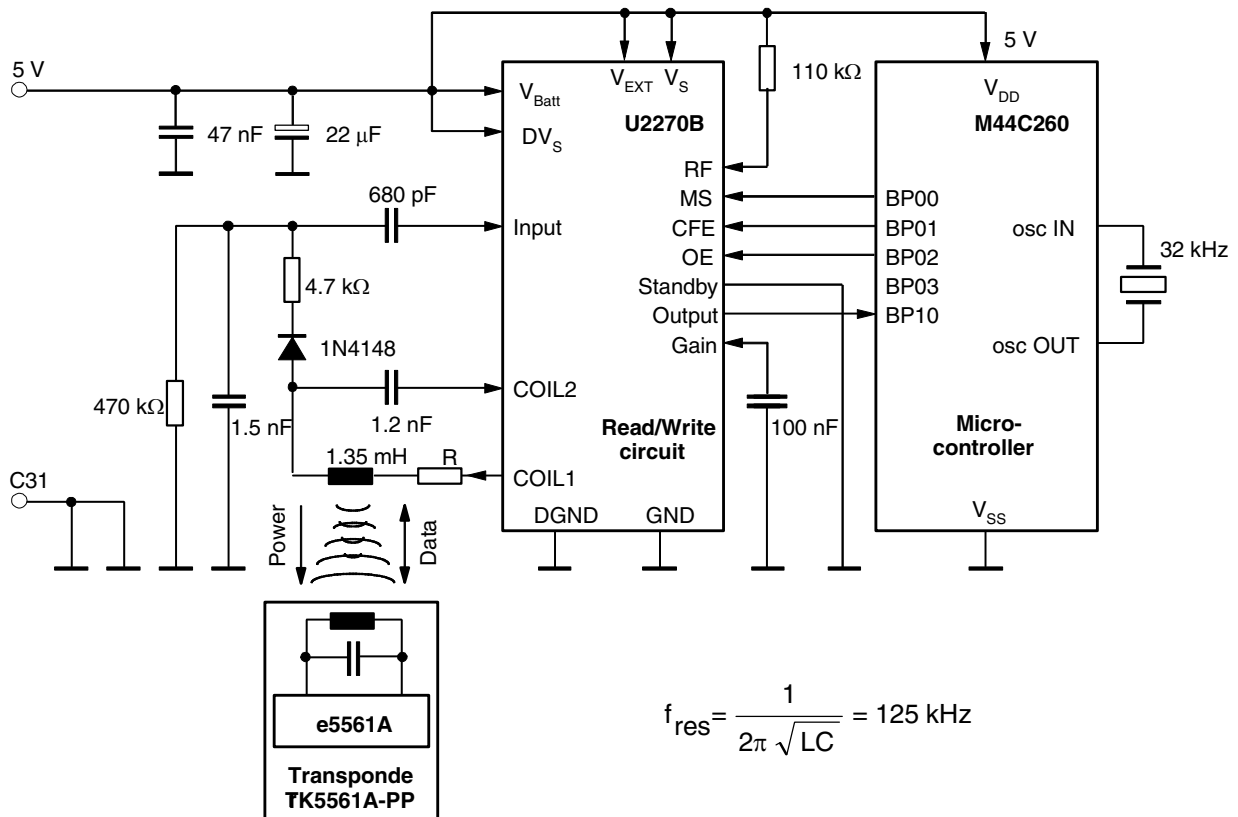

Mechanical Specification

Figure 11. Mechanical Drawing of Transponder

Dimensions in mm

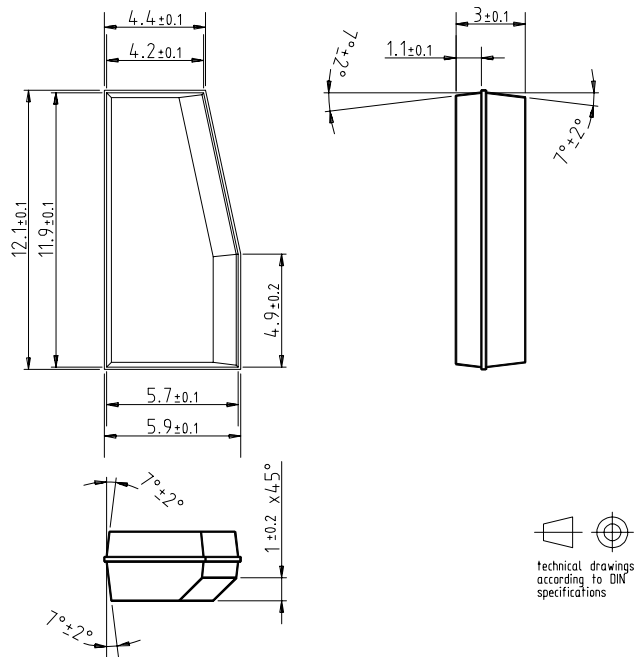

Ordering Information

Extended Type Number	Package	Remarks
TK5561A-PP	—	A = Version of e5561 IDIC



Atmel Headquarters

Corporate Headquarters

2325 Orchard Parkway
San Jose, CA 95131
TEL 1(408) 441-0311
FAX 1(408) 487-2600

Europe

Atmel Sarl
Route des Arsenaux 41
Case Postale 80
CH-1705 Fribourg
Switzerland
TEL (41) 26-426-5555
FAX (41) 26-426-5500

Asia

Room 1219
Chinachem Golden Plaza
77 Mody Road Tsimhatsui
East Kowloon
Hong Kong
TEL (852) 2721-9778
FAX (852) 2722-1369

Japan

9F, Tonetsu Shinkawa Bldg.
1-24-8 Shinkawa
Chuo-ku, Tokyo 104-0033
Japan
TEL (81) 3-3523-3551
FAX (81) 3-3523-7581

Atmel Operations

Memory

2325 Orchard Parkway
San Jose, CA 95131
TEL 1(408) 441-0311
FAX 1(408) 436-4314

Microcontrollers

2325 Orchard Parkway
San Jose, CA 95131
TEL 1(408) 441-0311
FAX 1(408) 436-4314

La Chantrerie
BP 70602
44306 Nantes Cedex 3, France
TEL (33) 2-40-18-18-18
FAX (33) 2-40-18-19-60

ASIC/ASSP/Smart Cards

Zone Industrielle
13106 Rousset Cedex, France
TEL (33) 4-42-53-60-00
FAX (33) 4-42-53-60-01

1150 East Cheyenne Mtn. Blvd.
Colorado Springs, CO 80906
TEL 1(719) 576-3300
FAX 1(719) 540-1759

Scottish Enterprise Technology Park
Maxwell Building
East Kilbride G75 0QR, Scotland
TEL (44) 1355-803-000
FAX (44) 1355-242-743

RF/Automotive

Theresienstrasse 2
Postfach 3535
74025 Heilbronn, Germany
TEL (49) 71-31-67-0
FAX (49) 71-31-67-2340

1150 East Cheyenne Mtn. Blvd.
Colorado Springs, CO 80906
TEL 1(719) 576-3300
FAX 1(719) 540-1759

Biometrics/Imaging/Hi-Rel MPU/ High Speed Converters/RF Datacom

Avenue de Rochepleine
BP 123
38521 Saint-Egreve Cedex, France
TEL (33) 4-76-58-30-00
FAX (33) 4-76-58-34-80

e-mail

literature@atmel.com

Web Site

<http://www.atmel.com>

© Atmel Corporation 2003.

Atmel Corporation makes no warranty for the use of its products, other than those expressly contained in the Company's standard warranty which is detailed in Atmel's Terms and Conditions located on the Company's web site. The Company assumes no responsibility for any errors which may appear in this document, reserves the right to change devices or specifications detailed herein at any time without notice, and does not make any commitment to update the information contained herein. No licenses to patents or other intellectual property of Atmel are granted by the Company in connection with the sale of Atmel products, expressly or by implication. Atmel's products are not authorized for use as critical components in life support devices or systems.

Atmel® is the registered trademark of Atmel.

IDIC® stands for IDentification Integrated Circuit and is a registered trademark of Atmel Germany GmbH.

Other terms and product names may be the trademarks of others.



Printed on recycled paper.