



TK610xx

ADVANCED INFORMATION

VOLTAGE DETECTOR

FEATURES

- Very Low Quiescent Current (1 μ A)
- No External Components
- Built In Hysteresis (5% typ.)
- ± 2 % Voltage Detection Accuracy
- Miniature Package (SOT23-5)

APPLICATIONS

- Battery Powered Systems
- Wireless Telephones
- Pagers
- Personal Communications Equipment
- Personal Digital Assistants

DESCRIPTION

The TK610xx family of voltage detectors is designed to provide accurate monitoring of the battery voltage. These low powered CMOS devices require no external components and are available in 0.1 V steps from 2.0 V to 5.0 V.

When the input voltage reaches the detection voltage, the output goes low. This detection voltage has a ± 2 % accuracy and is set at the factory. When the input voltage goes high, the output will stay low until the voltage reaches the detection voltage plus hysteresis (+3 to +7 %).

The TK610xx is available in a miniature SOT23-5 surface mount package.

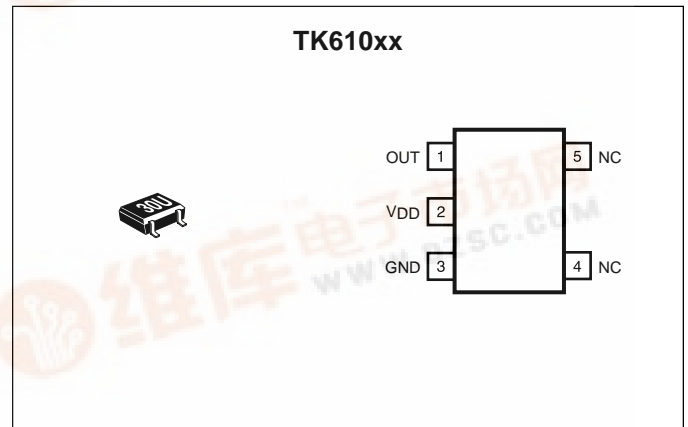

ORDERING INFORMATION

TK610□□S□□

Voltage Code Tape/Reel Code

VOLTAGE CODE *

23 = 2.3 V	36 = 3.6 V
25 = 2.5 V	40 = 4.0 V
27 = 2.7 V	41 = 4.1 V
30 = 3.0 V	42 = 4.2 V
33 = 3.3 V	45 = 4.5 V

TAPE/REEL CODE
TL: Tape Left

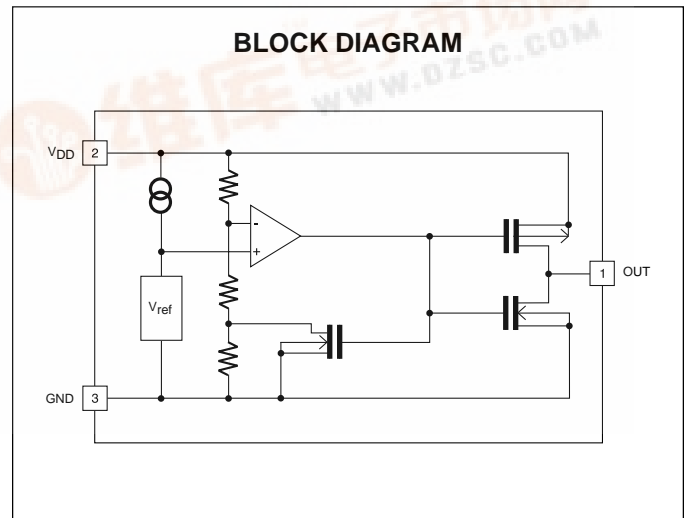

* Consult factory for availability of other voltages

TK610xx

ABSOLUTE MAXIMUM RATINGS

All Pins Except GND 11 V Operating Temperature Range -30 to +80 °C
 Power Dissipation (Note 4) 400 mW Junction Temperature 150 °C
 Storage Temperature Range -40 to +125 °C

TK610xx ELECTRICAL CHARACTERISTICS

T_A = 25 °C, unless otherwise specified.

SYMBOL	PARAMETER	TEST CONDITIONS	MIN	TYP	MAX	UNITS
V _{ERR}	Voltage Accuracy	Note 1	-2		+2	%
HYS	Hysteresis	Note 2	3	5	7	%
V _{DDH}	Maximum Operating Voltage		9			V
V _{DDL}	Lowest Operating Voltage				0.8	V
$\frac{\Delta V_{DET}}{V_{DET} * \Delta T}$	Detection Voltage Temperature Coefficient	-30 °C ≤ top ≤ 80 °C		±100		ppm/°C
t _{DR}	Rise Propagation Delay Time	Note 3		100		µsec
I _{SSL}	Supply Current (L)	V _{DD} = 1.0 V			1.0	µA
I _{SSM}	Supply Current (M)	V _{DD} = 5.0 V, 2.0 V ≤ Setting Voltage ≤ 5.0 V		1.0	2.0	µA
I _{SSH}	Supply Current (H)	V _{DD} = 7.0 V, 4.2 V ≤ Setting Voltage ≤ 5.0 V		1.5	3.0	µA
I _{ON1}	Output Current (N1) (Note 5)	V _{DS} = 0.05 V, V _{DD} = 0.8 V	0.01	0.05		mA
I _{ON2}	Output Current (N2) (Note 5)	V _{DS} = 0.5 V, V _{DD} = 1.5 V	2.0	4.0		mA
I _{OP1}	Output Current (P1) (Note 6)	V _{DS} = 2.1 V, V _{DD} = 4.5 V, 2.0 V ≤ Setting Voltage ≤ 4.1 V	2.0	4.0		mA
I _{OP1}	Output Current (P1) (Note 6)	V _{DS} = 2.1 V, V _{DD} = 7.0 V, 4.2 V ≤ Setting Voltage ≤ 5.0 V	6.0	8.0		mA

Note 1: V_{ERR} = 100 * (V_{DET} - Setting Voltage) / Setting Voltage expressed in %

Note 2: HYS = 100 * (V_{HYS} - V_{DET}) / V_{DET} expressed in %

Note 3: The applied voltage is a pulse of V_{LOW} = 0.8 V, V_{HIGH} = V_{DET} + 2 V

Note 4: Power dissipation is 400 mW when mounted as recommended. Derate at 3.2 mW/°C for operation above 25 °C.
 Power dissipation is 200 mW in Free Air. Derate at 1.6 mW/°C for operation above 25 °C.

Note 5: Output sink current.

Note 6: Output source current.

TEST CIRCUIT

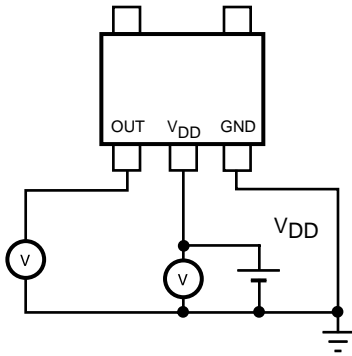

FIGURE 1: TEST CIRCUIT FOR V_{DET} , V_{HYS} , V_{DDH} ,
 V_{DDL} , t_{DR}

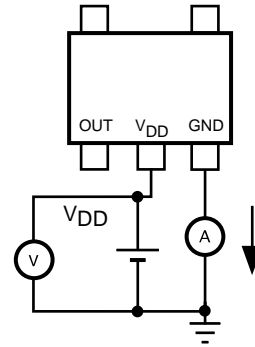

FIGURE 3: TEST CIRCUIT FOR I_{SS}

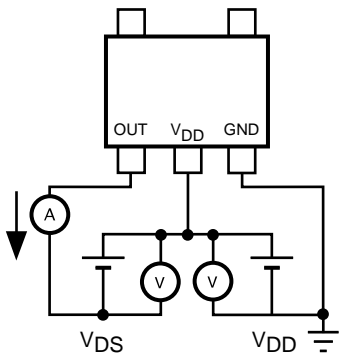

FIGURE 2: TEST CIRCUIT FOR I_{OP}

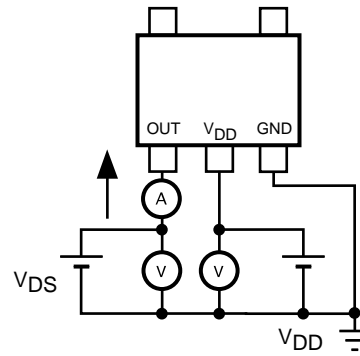
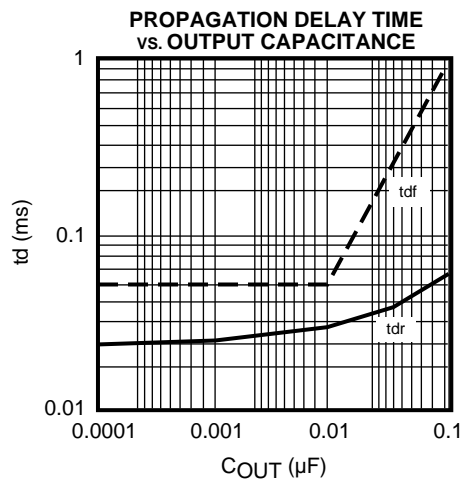
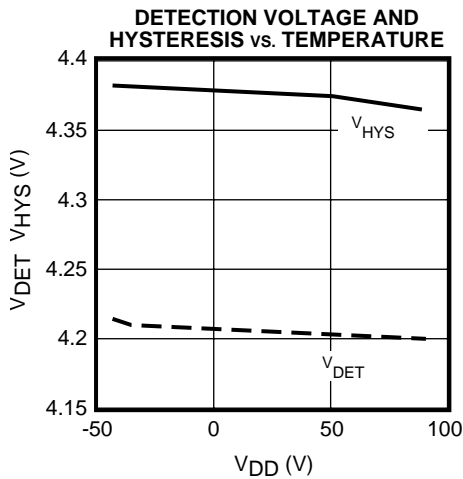
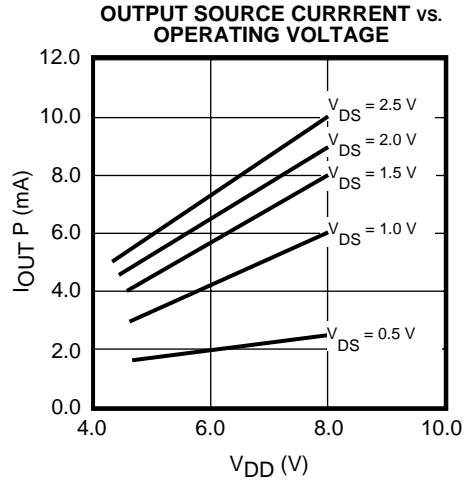
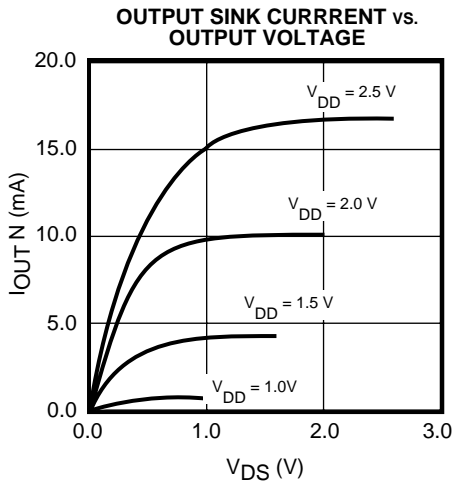
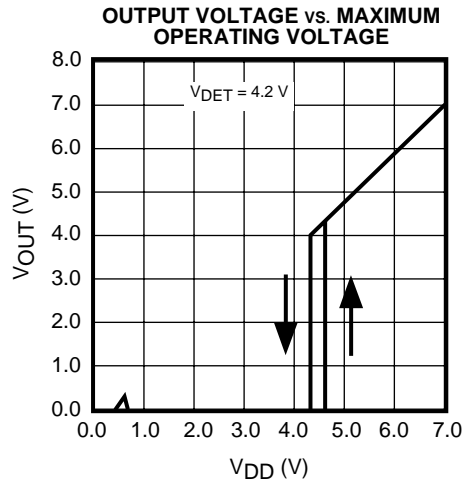
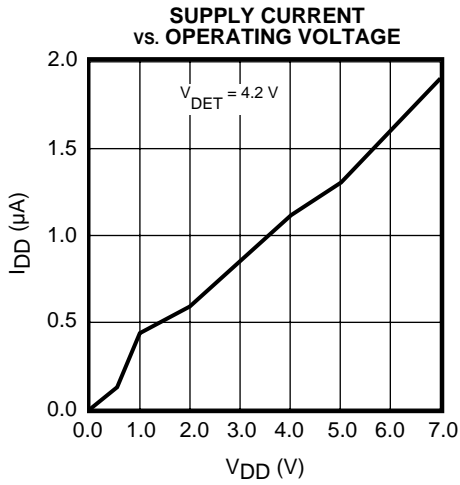

FIGURE 4: TEST CIRCUIT FOR I_{ON}

TYPICAL PERFORMANCE CHARACTERISTICS



DEFINITION AND EXPLANATION OF TECHNICAL TERMS

DETECTION VOLTAGE (V_{DET})

When V_{DD} goes below the detection voltage, the output goes low.

HYSTERESIS VOLTAGE (V_{HYS})

When V_{DD} goes above the sum of the detection voltage and the hysteresis voltage, the output goes high.

SUPPLY CURRENT (I_{SSL})

Supply current ($V_{DD} = 1\text{ V}$)

SUPPLY CURRENT (I_{SSM})

Supply current ($V_{DD} = 5\text{ V}$) $2.0\text{ V} \leq \text{setting voltage} \leq 4.1\text{ V}$

SUPPLY CURRENT (I_{SSH})

Supply current ($V_{DD} = 7\text{ V}$) $4.2 \leq \text{setting voltage} \leq 5.0\text{ V}$

OUTPUT CURRENT (I_{ON1})

Output sink current of output N channel FET
 $V_{DD} = 0.8\text{ V}$, $V_{DS} = 0.5\text{ V}$

OUTPUT CURRENT (I_{ON2})

Output sink current of output N channel FET
 $V_{DD} = 1.5\text{ V}$, $V_{DS} = 0.5\text{ V}$

OUTPUT CURRENT (I_{OP1})

Output source current of output P channel FET
 $V_{DD} = 4.5\text{ V}$, $V_{DS} = 2.1\text{ V}$, $2.0\text{ V} \leq \text{setting voltage} \leq 4.1\text{ V}$

VOLTAGE ACCURACY (V_{ERR})

Error ratio of set voltage
 $V_{ERR} = 100 * (V_{DET} - \text{Setting Voltage}) / \text{Setting Voltage}$
expressed in %

HYSTERESIS (HYS)

Ratio of hysteresis voltage to detection voltage
 $HYS = 100 * (V_{HYS} - V_{DET}) / V_{DET}$ expressed in %

MAXIMUM OPERATING VOLTAGE (V_{DDH})

The maximum operating voltage.

LOWEST OPERATING VOLTAGE (V_{DDL})

Voltage when V_{DD} is reduced and output goes up from 0 V to 100 mV.

DETECTION VOLTAGE TEMPERATURE COEFFICIENT ($\Delta V_{DET} / V_{DET} * \Delta T$)

Temperature coefficient of detection voltage.

$$\frac{\Delta V_{DET}}{V_{DET} * \Delta T} = \frac{1000000 * (V_{DET}(T) - V_{DET}(25\text{ }^\circ\text{C}))}{V_{DET}(25\text{ }^\circ\text{C}) * (T - 25\text{ }^\circ\text{C})}$$

RISE PROPAGATION DELAY TIME (t_{DR})

The delay time for the output to reach $(V_{DET} + 2.0\text{ V}) / 2$ when V_{DD} goes from $V_{LOW} = 0.8\text{ V}$ to $V_{HIGH} = V_{DET} + 2.0\text{ V}$

OUTPUT CHARACTERISTICS

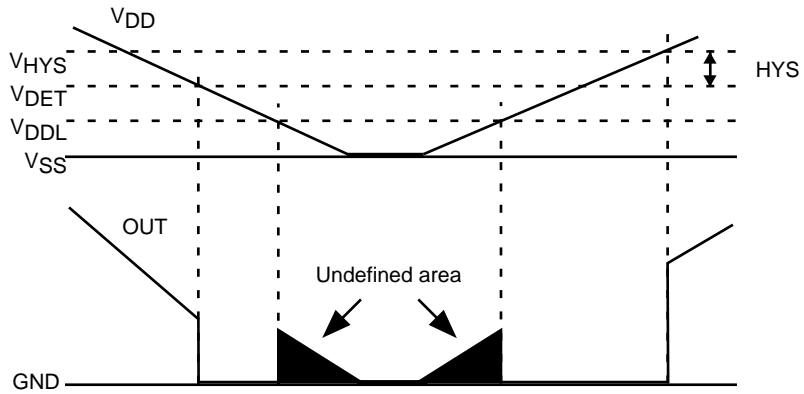

OUTPUT vs. SUPPLY VOLTAGE

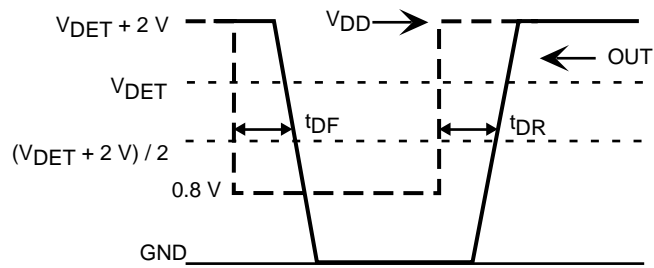

OUTPUT PROPAGATION DELAY

APPLICATION INFORMATION

CHANGING DETECTION VOLTAGE USING EXTERNAL RESISTORS

It is not recommended to set the detection voltage using external resistors (See figure below) as oscillations may occur.

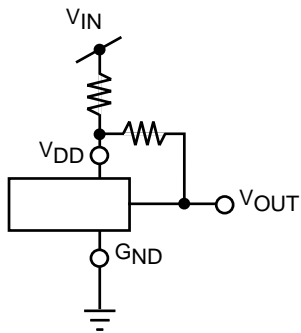

Note: For the TK610xx, there is an internal diode between GND and Output and another diode between Output and V_{DD} . Current will flow between these terminals if the diodes are forward biased. See the figure below for diode polarity.

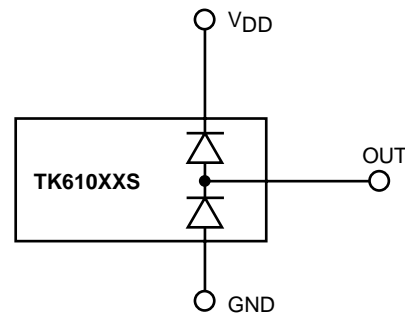

OUTPUT H CHARACTERISTICS FOR $V_{DD} < V_{DD1}$

The output voltage is not defined when $V_{DD} < V_{DDL}$.

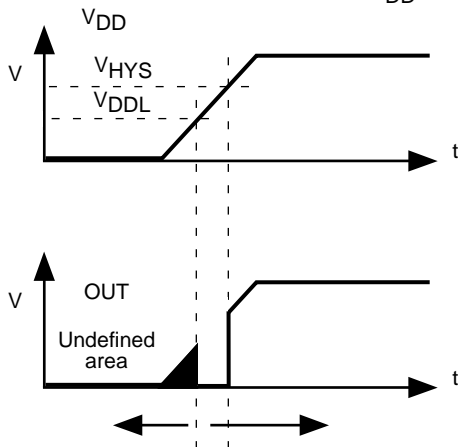

PACKAGE OUTLINE

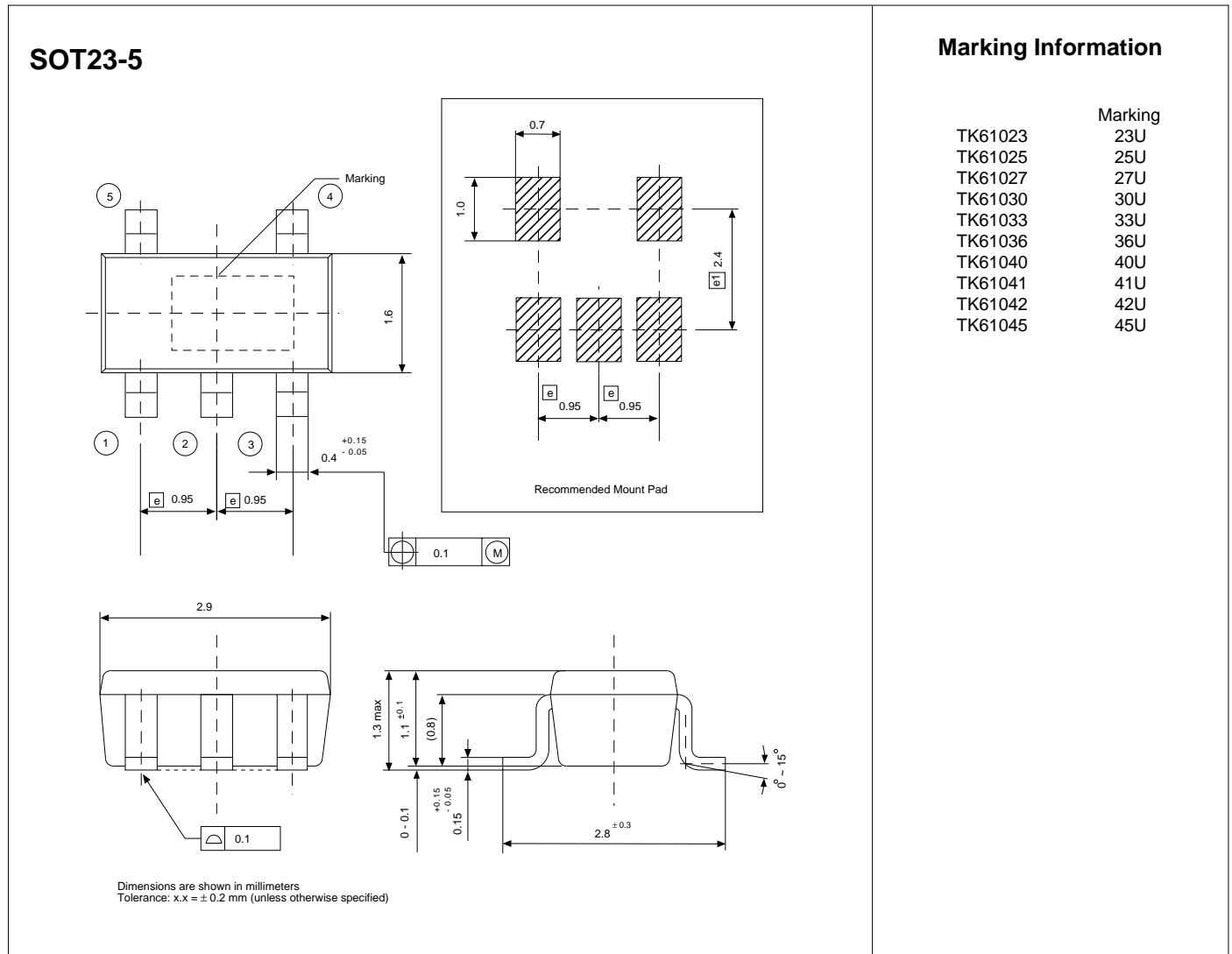

Toko America, Inc. Headquarters
 1250 Feehanville Drive, Mount Prospect, Illinois 60056
 Tel: (847) 297-0070 Fax: (847) 699-7864

TOKO AMERICA REGIONAL OFFICES

Midwest Regional Office
 Toko America, Inc.
 1250 Feehanville Drive
 Mount Prospect, IL 60056
 Tel: (847) 297-0070
 Fax: (847) 699-7864

Western Regional Office
 Toko America, Inc.
 2480 North First Street, Suite 260
 San Jose, CA 95131
 Tel: (408) 432-8281
 Fax: (408) 943-9790

Eastern Regional Office
 Toko America, Inc.
 107 Mill Plain Road
 Danbury, CT 06811
 Tel: (203) 748-6871
 Fax: (203) 797-1223

Semiconductor Technical Support
 Toko Design Center
 4755 Forge Road
 Colorado Springs, CO 80907
 Tel: (719) 528-2200
 Fax: (719) 528-2375

Visit our Internet site at <http://www.tokoam.com>

The information furnished by TOKO, Inc. is believed to be accurate and reliable. However, TOKO reserves the right to make changes or improvements in the design, specification or manufacture of its products without further notice. TOKO does not assume any liability arising from the application or use of any product or circuit described herein, nor for any infringements of patents or other rights of third parties which may result from the use of its products. No license is granted by implication or otherwise under any patent or patent rights of TOKO, Inc.