

TLGE18TP

Product Features -

- InGaAlP Technology
- 5mm Diameter T-1 $\frac{1}{4}$ Package
- High Luminous Intensity
- Water Clear Lens
- Excellent ON-OFF Contrast Ratio

MAXIMUM RATINGS (Ta = 25°C)

CHARACTERISTIC	SYMBOL	RATING	UNIT
Forward Current	I _F	50	mA
Reverse Voltage	V _R	4	V
Power Dissipation	P _D	120	mW
Operating Temperature	T _{opr}	-40 ~ 100	°C
Storage Temperature	T _{stg}	-40 ~ 120	°C

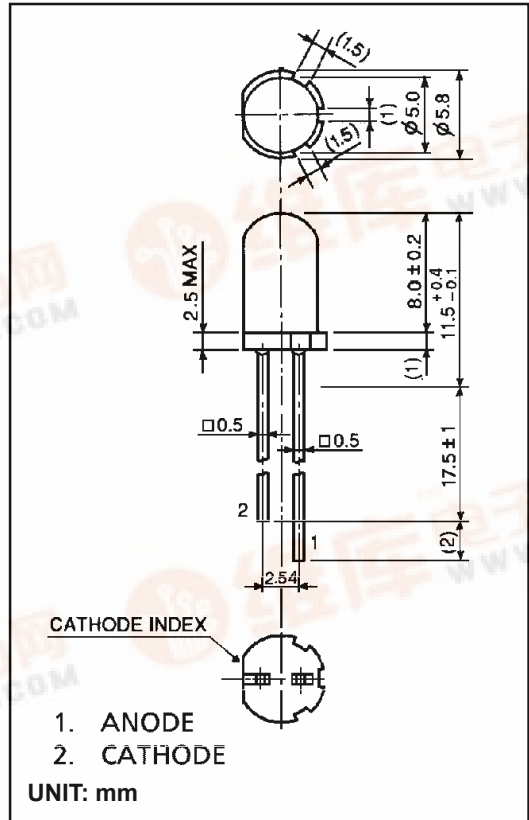

OPTO-ELECTRICAL CHARACTERISTICS (Ta = 25°C)

CHARACTERISTIC	SYMBOL	TEST CONDITION	MIN.	TYP.	MAX.	UNIT
Forward Voltage	V _F	IF = 20mA	—	2.0	2.4	V
Reverse Current	I _R	VR = 4V	—	—	50	μA
Luminous Intensity	I _v	IF = 20mA	272	700	—	mcd
Viewing Angle	2θ $\frac{1}{2}$	—	—	28	—	°
Peak Wavelength	λ _p	IF = 20mA	—	574	—	nm
Dominant Wavelength	λ _d	IF = 20mA	—	571	—	nm
Spectral Line Half Width	Δλ	IF = 20mA	—	17	—	nm



TLGE18TP Graphs -

