



Airflow and Temperature Sensor

TMP12*

FEATURES

- Temperature Sensor Includes 100 Ω Heater
- Heater Provides Power IC Emulation
- Accuracy $\pm 3^{\circ}\text{C}$ typ. from -40°C to $+100^{\circ}\text{C}$
- Operation to $+150^{\circ}\text{C}$
- 5 mV/ $^{\circ}\text{C}$ Internal Scale-Factor
- Resistor Programmable Temperature Setpoints
- 20 mA Open-Collector Setpoint Outputs
- Programmable Thermal Hysteresis
- Internal 2.5 V Reference
- Single 5 V Operation
- 400 μA Quiescent Current (Heater OFF)
- Minimal External Components

APPLICATIONS

- System Airflow Sensor
- Equipment Over-Temperature Sensor
- Over-Temperature Protection
- Power Supply Thermal Sensor
- Low-Cost Fan Controller

GENERAL DESCRIPTION

The TMP12 is a silicon-based airflow and temperature sensor designed to be placed in the same airstream as heat generating components that require cooling. Fan cooling may be required continuously, or during peak power demands, e.g. for a power supply, and if the cooling systems fails, system reliability and/or safety may be impaired. By monitoring temperature while emulating a power IC, the TMP12 can provide a warning of cooling system failure.

The TMP12 generates an internal voltage that is linearly proportional to Celsius (Centigrade) temperature, nominally $+5\text{ mV}/^{\circ}\text{C}$. The linearized output is compared with voltages from an external resistive divider connected to the TMP12's 2.5 V precision reference. The divider sets up one or two reference voltages, as required by the user, providing one or two temperature setpoints. Comparator outputs are open-collector transistors able to sink over 20 mA. There is an on-board hysteresis generator provided to speed up the temperature-setpoint output transitions, this also reduces erratic output transitions in noisy environments. Hysteresis is programmed by the external resistor chain and is determined by the total current drawn from the 2.5 V reference. The TMP12 airflow sensor also incorporates a precision, low temperature coefficient 100 Ω heater resistor that may be connected directly to an external 5 V supply. When the heater is activated it raises the die temperature in

FUNCTIONAL BLOCK DIAGRAM

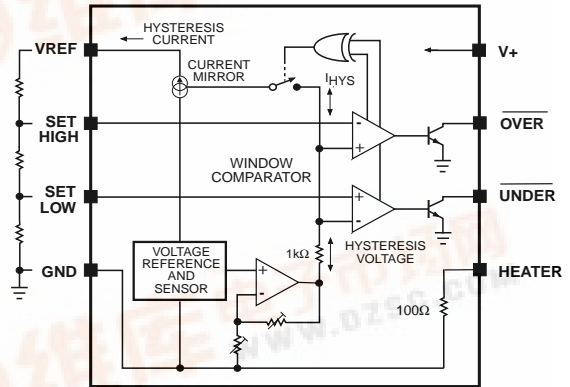

PINOUTS DIP And SO

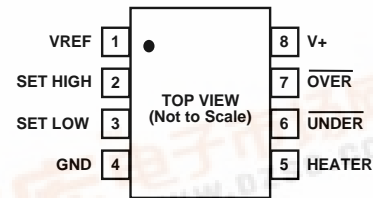

the DIP package approximately 20°C above ambient (in still air). The purpose of the heater in the TMP12 is to emulate a power IC, such as a regulator or Pentium CPU which has a high internal dissipation.

When subjected to a fast airflow, the package and die temperatures of the power device and the TMP12 (if located in the same airstream) will be reduced by an amount proportional to the rate of airflow. The internal temperature rise of the TMP12 may be reduced by placing a resistor in series with the heater, or reducing the heater voltage.

The TMP12 is intended for single 5 V supply operation, but will operate on a 12 V supply. The heater is designed to operate from 5 V only. Specified temperature range is from -40°C to $+125^{\circ}\text{C}$, operation extends to $+150^{\circ}\text{C}$ at 5 V with reduced accuracy.

The TMP12 is available in 8-pin plastic DIP and SO packages.

*Protected by U.S. Patent No. 5,195,827.



TMP12—SPECIFICATIONS (V_S = +5 V, -40°C ≤ T_A ≤ +125°C unless otherwise noted.)

Parameter	Symbol	Conditions	Min	Typ	Max	Units
ACCURACY						
Accuracy (High, Low Setpoints)		T _A = +25°C		±2	±3	°C
Accuracy (High, Low Setpoints)		T _A = -40°C to +100°C		±3	±5	°C
Internal Scale Factor		T _A = -40°C to +100°C	+4.9	+5	+5.1	mV/°C
Power Supply Rejection Ratio	PSRR	4.5 V ≤ +V _S ≤ 5.5 V		0.1	0.5	°C/V
Linearity		T _A = -40°C to +125°C		0.5		°C
Repeatability		T _A = -40°C to +125°C		0.3		°C
Long Term Stability		T _A = +125°C for 1 k Hrs		0.3		°C
SETPOINT INPUTS						
Offset Voltage	V _{OS}			0.25		mV
Output Voltage Drift	TCV _{OS}			3		μV/°C
Input Bias Current	I _B			25	100	nA
VREF OUTPUT						
Output Voltage	VREF	T _A = +25°C, No Load	2.49	2.50	2.51	V
Output Voltage	VREF	T _A = -40°C to +100°C, No Load		2.5 ±0.015		V
Output Drift	TCV _{VREF}			-10		ppm/°C
Output Current, Zero Hysteresis	I _{VREF}			7		μA
Hysteresis Current Scale Factor	SF _{HYS}			5		μA/°C
OPEN-COLLECTOR OUTPUTS						
Output Low Voltage	V _{OL}	I _{SINK} = 1.6 mA		0.25	0.4	V
Output Low Voltage	V _{OL}	I _{SINK} = 20 mA		0.6		V
Output Leakage Current	I _{OH}	V _S = 12 V		1	100	μA
Fall Time	t _{HL}	See Test Load		40		ns
HEATER						
Resistance	R _H	T _A = +25°C	97	100	103	Ω
Temperature Coefficient		T _A = -40°C to +125°C		100		ppm/°C
Maximum Continuous Current	I _H	See Note 1			60	mA
POWER SUPPLY						
Supply Range	+V _S		4.5		5.5	V
Supply Current	I _{SY}	Unloaded at +5 V		400	600	μA
	I _{SY}	Unloaded at +12 V ²		450		μA

NOTES

¹Guaranteed but not tested.

²TMP12 is specified for operation from a 5 V supply. However, operation is allowed up to a 12 V supply, but not tested at 12 V. Maximum heater supply is 6 V.

Specifications subject to change without notice.

TEST LOAD

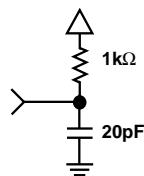

WAFER TEST LIMITS ($V_S = +5\text{ V}$, $GND = 0\text{ V}$, $T_A = +25^\circ\text{C}$, unless otherwise noted.)

Parameter	Symbol	Conditions	Min	Typ	Max	Units
ACCURACY Accuracy (High, Low Setpoints) Internal Scale Factor		$T_A = +25^\circ\text{C}$ $T_A = +25^\circ\text{C}$	+4.9	+5	± 3 +5.1	$^\circ\text{C}$ mV/ $^\circ\text{C}$
SETPOINT INPUTS Input Bias Current	I_B				100	nA
VREF OUTPUT Output Voltage	VREF	$T_A = +25^\circ\text{C}$, No Load	2.49		2.51	V
OPEN-COLLECTOR OUTPUTS Output Low Voltage Output Leakage Current	V_{OL} I_{OH}	$I_{SINK} = 1.6\text{ mA}$ $V_S = 12\text{ V}$			0.4 100	V μA
HEATER Resistance	R_H	$T_A = +25^\circ\text{C}$	97	100	103	Ω
POWER SUPPLY Supply Range Supply Current	$+V_S$ I_{SY}	Unloaded at +5 V	4.5		5.5 600	V μA

NOTE

Electrical tests are performed at wafer probe to the limits shown. Due to variations in assembly methods and normal yield loss, yield after packaging is not guaranteed for standard product dice. Consult factory to negotiate specifications based on dice lot qualification through sample lot assembly and testing.

DICE CHARACTERISTICS

Die Size 0.078×0.071 inch, 5,538 sq. mils

(1.98×1.80 mm, 3.57 sq. mm)

Transistor Count: 105

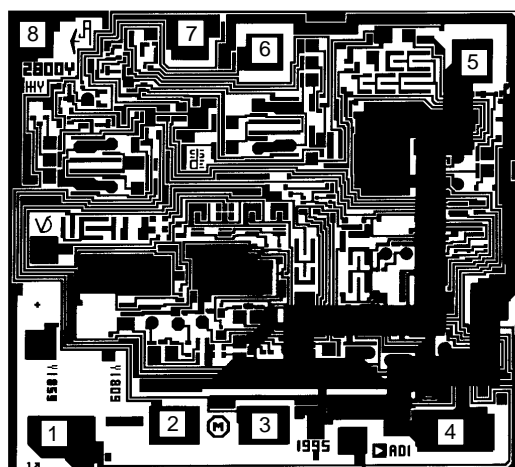

1. VREF
2. SET HIGH INPUT
3. SET LOW INPUT
4. GND
5. HEATER
6. UNDER OUTPUT
7. OVER OUTPUT
8. V+

For additional DICE ordering information, refer to databook.

CAUTION

ESD (electrostatic discharge) sensitive device. Electrostatic charges as high as 4000 V readily accumulate on the human body and test equipment and can discharge without detection. Although the TMP12 features proprietary ESD protection circuitry, permanent damage may occur on devices subjected to high energy electrostatic discharges. Therefore, proper ESD precautions are recommended to avoid performance degradation or loss of functionality.



TMP12

ABSOLUTE MAXIMUM RATINGS*

Supply Voltage	-0.3 V to +15 V
Heater Voltage	+6 V
Setpoint Input Voltage	-0.3 V to [(V+) +0.3 V]
Reference Output Current	2 mA
Open-Collector Output Current	50 mA
Open-Collector Output Voltage	+15 V
Operating Temperature Range	-55°C to +150°C
Dice Junction Temperature	+175°C
Storage Temperature Range	-65°C to +160°C
Lead Temperature(Soldering, 60 sec)	+300°C

Package Type	Θ_{JA}	Θ_{JC}	Units
8-Pin Plastic DIP (P)	103 ¹	43	°C/W
8-Lead SOIC (S)	158 ²	43	°C/W

NOTES

¹ Θ_{JA} is specified for device in socket (worst case conditions).

² Θ_{JA} is specified for device mounted on PCB.

CAUTION

- Stresses above those listed under “Absolute Maximum Ratings” may cause permanent damage to the device. This is a stress rating only and functional operation at or above this specification is not implied. Exposure to the above maximum rating conditions for extended periods may affect device reliability.
- Digital inputs and outputs are protected, however, permanent damage may occur on unprotected units from high-energy electrostatic fields. Keep units in conductive foam or packaging at all times until ready to use. Use proper antistatic handling procedures.
- Remove power before inserting or removing units from their sockets.

ORDERING GUIDE

Model/Grade	Temperature Range ¹	Package Description	Package Option
TMP12FP	XIND	Plastic DIP	N-8
TMP12FS	XIND	SOIC	SO-8
TMP12GBC	+25°C	Die	

NOTE

¹XIND = -40°C to +125°C

FUNCTIONAL DESCRIPTION

The TMP12 incorporates a heating element, temperature sensor, and two user-selectable setpoint comparators on a single substrate. By generating a known amount of heat, and using the setpoint comparators to monitor the resulting temperature rise, the TMP12 can indirectly monitor the performance of a system’s cooling fan.

The TMP12 temperature sensor section consists of a bandgap voltage reference which provides both a constant 2.5 V output and a voltage which is proportional to absolute temperature (VPTAT). The VPTAT has a precise temperature coefficient of 5 mV/K and is 1.49 V (nominal) at +25°C. The comparators compare VPTAT with the externally set temperature trip points and generate an open-collector output signal when one of their respective thresholds has been exceeded.

The heat source for the TMP12 is an on-chip 100 Ω low tempco thin-film resistor. When connected to a 5 V source, this resistor dissipates:

$$P_D = \frac{V^2}{R} = \frac{5^2 V}{100 \Omega} = 0.25 W,$$

which generates a temperature rise of about 32°C in still air for the SO packaged device. With an airflow of 450 feet per minute (FPM), the temperature rise is about 22°C. By selecting a temperature setpoint between these two values, the TMP12 can provide a logic-level indication of problems in the cooling system.

A proprietary, low tempco thin-film resistor process, in conjunction with production laser trimming, enables the TMP12 to provide a temperature accuracy of $\pm 3^\circ\text{C}$ (typ) over the rated temperature range. The open-collector outputs are capable of sinking 20 mA, allowing the TMP12 to drive small control relays directly. Operating from a single +5 V supply, the quiescent current is only 600 μA (max), without the heater resistor current.

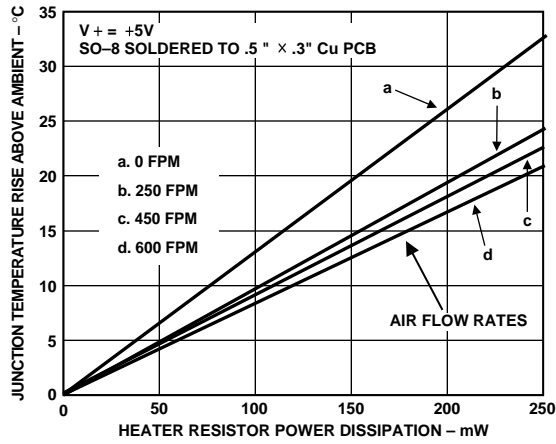

Figure 1. SOIC Junction Temperature Rise vs. Heater Dissipation

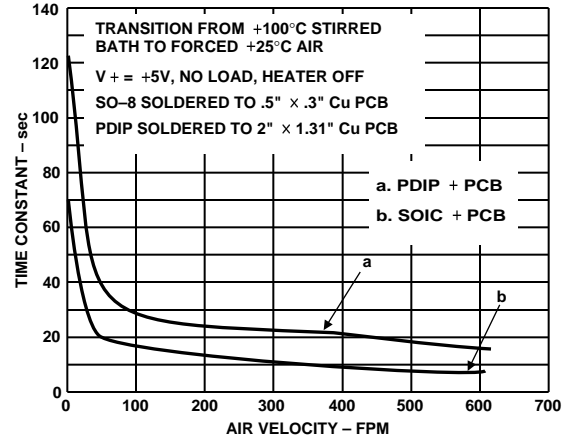

Figure 4. Package Thermal Time Constant in Forced Air

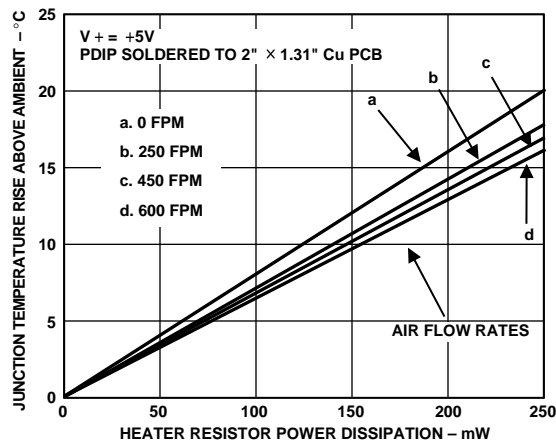

Figure 2. PDIP Junction Temperature Rise vs. Heater Dissipation

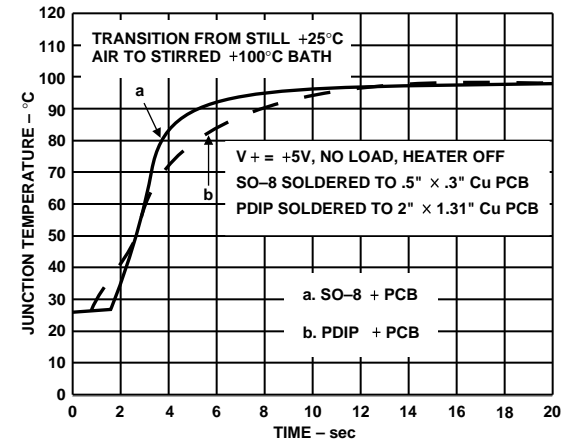

Figure 5. Thermal Response Time in Stirred Oil Bath

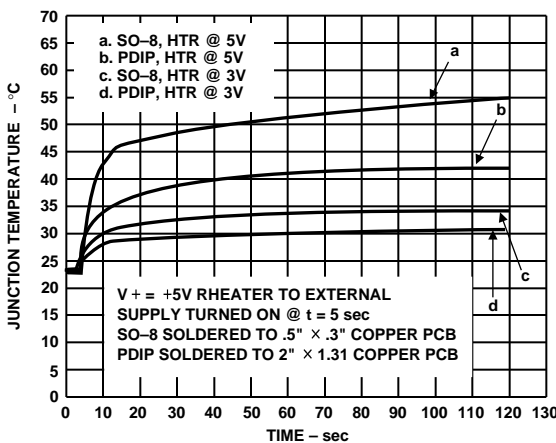

Figure 3. Junction Temperature Rise in Still Air

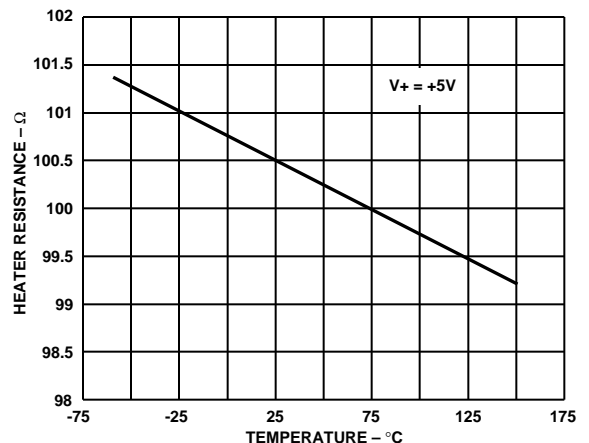

Figure 6. Heater Resistance vs. Temperature

TMP12

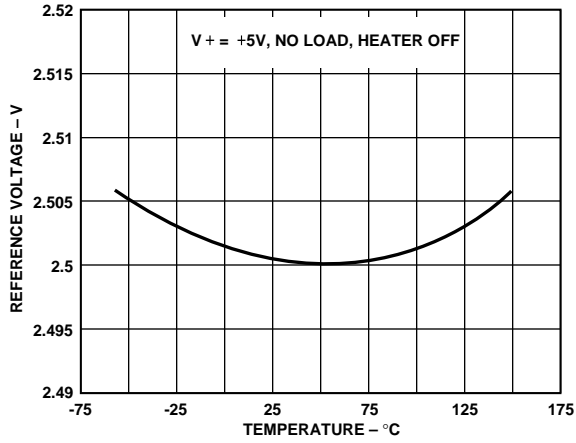

Figure 7. Reference Voltage vs. Temperature

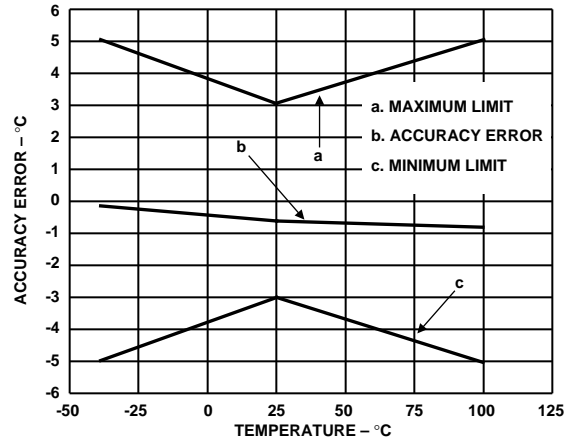

Figure 10. Accuracy Error vs. Temperature

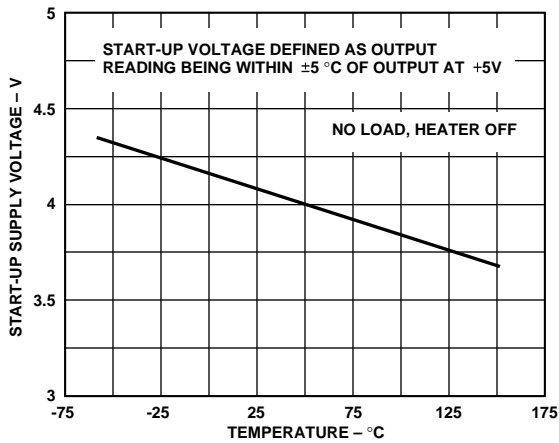

Figure 8. Start-up Voltage vs. Temperature

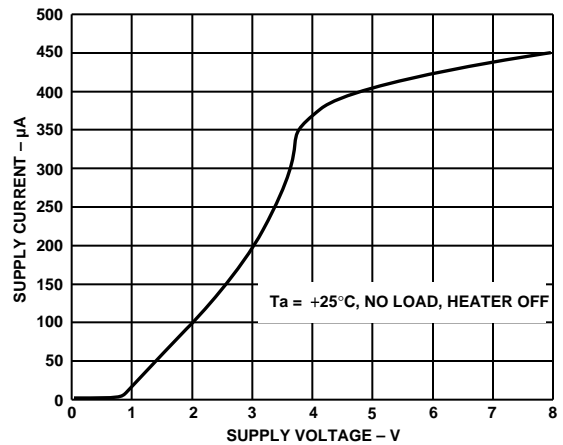

Figure 11. Supply Current vs. Supply Voltage

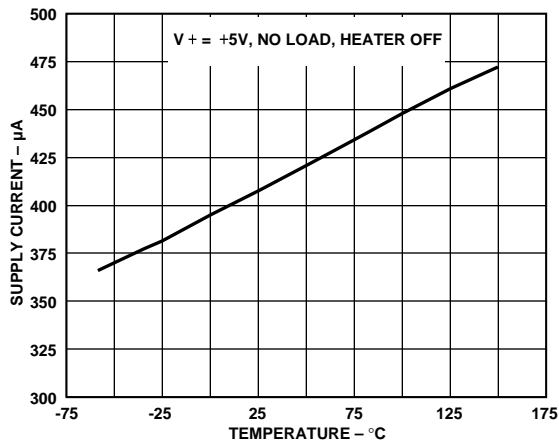

Figure 9. Supply Current vs. Temperature

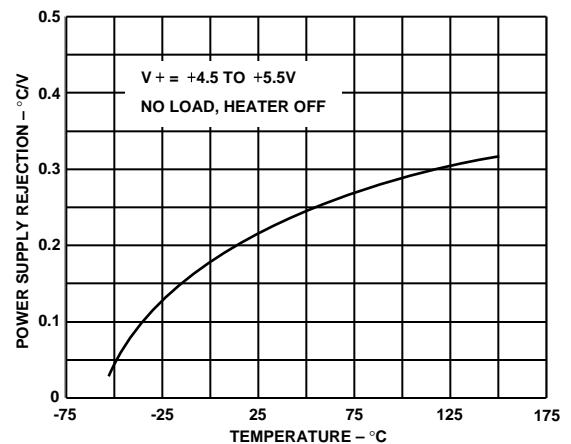

Figure 12. VPTAT Power Supply Rejection vs. Temperature

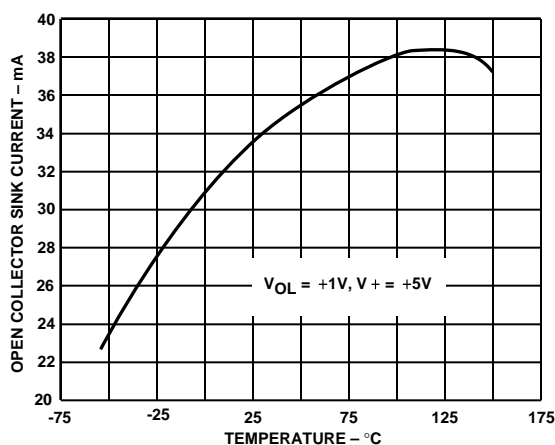

Figure 13. Open-Collector Output Sink Current vs. Temperature

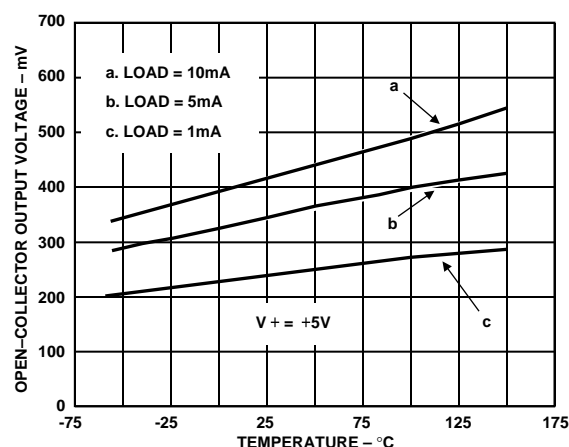

Figure 14. Open-Collector Voltage vs. Temperature

APPLICATIONS INFORMATION

A typical application for the TMP12 is shown in Figure 15. The TMP12 package is placed in the same cooling airflow as a high-power dissipation IC. The TMP12's internal resistor produces a temperature rise which is proportional to air flow, as shown in Figure 16. Any interruption in the airflow will produce an additional temperature rise. When the TMP12 chip temperature exceeds a user-defined setpoint limit, the system controller can take corrective action, such as: reducing clock frequency, shutting down unneeded peripherals, turning on additional fan cooling, or shutting down the system.

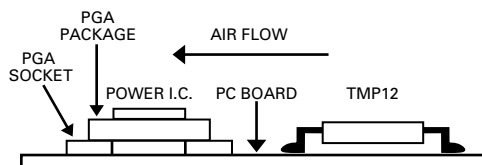

Figure 15. Typical Application

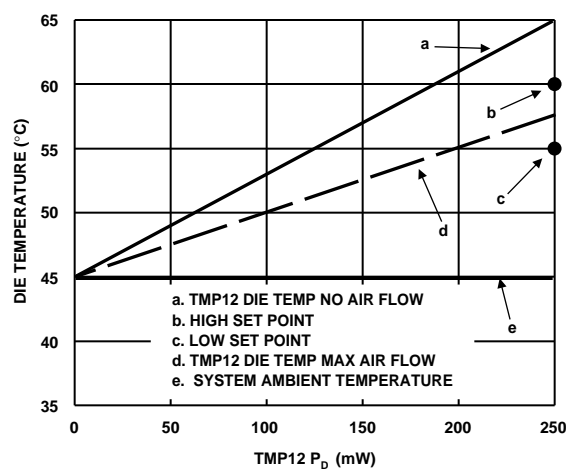

Figure 16. Choosing Temperature Setpoints

Temperature Hysteresis

The temperature hysteresis at each setpoint is the number of degrees beyond the original setpoint temperature that must be sensed by the TMP12 before the setpoint comparator will be reset and the output disabled. Hysteresis prevents “chatter” and “motorboating” in feedback control systems. For monitoring temperature in computer systems, hysteresis prevents multiple interrupts to the CPU which can reduce system performance.

Figure 17 shows the TMP12's hysteresis profile. The hysteresis is programmed, by the user, by setting a specific load current on the reference voltage output V_{REF} . This output current, I_{REF} , is also called the hysteresis current. I_{REF} is mirrored internally by the TMP12, as shown in the functional block diagram, and fed to a buffer with an analog switch.

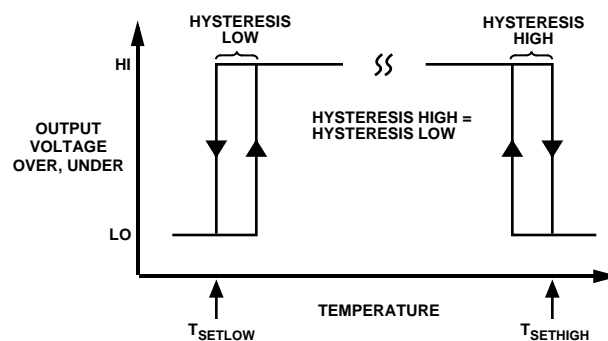

Figure 17. TMP12 Hysteresis Profile

After a temperature setpoint has been exceeded and a comparator tripped, the hysteresis buffer output is enabled. The result is a current of the appropriate polarity which generates a hysteresis offset voltage across an internal $1\text{ k}\Omega$ resistor at the comparator input. The comparator output remains “on” until the voltage at the comparator input, now equal to the temperature sensor voltage V_{PTAT} summed with the hysteresis effect, has returned to the programmed setpoint voltage. The comparator then returns

TMP12

LOW, deactivating the open-collector output and disabling the hysteresis current buffer output. The scale factor for the programmed hysteresis current is:

$$I = I_{VREF} = 5 \mu A/^{\circ}C + 7 \mu A$$

Thus, since $V_{REF} = 2.5 V$, a reference load resistance of $357 k\Omega$ or greater (output current of $7 \mu A$ or less) will produce a temperature setpoint hysteresis of zero degrees. For more details, see the temperature programming discussion below. Larger values of load resistance will only decrease the output current below $7 \mu A$, but will have no effect on the operation of the device. The amount of hysteresis is determined by selecting an appropriate value of load resistance for V_{REF} , as shown below.

Programming the TMP12

The basic thermal monitoring application only requires a simple three-resistor ladder voltage divider to set the high and low setpoints and the hysteresis. These resistors are programmed in the following sequence:

1. Select the desired hysteresis temperature.
2. Calculate the hysteresis current, I_{VREF}
3. Select the desired setpoint temperatures.
4. Calculate the individual resistor divider ladder values needed to develop the desired comparator setpoint voltages at the Set High and Set Low inputs.

The hysteresis current is readily calculated, as shown above. For example, to produce 2 degrees of hysteresis I_{VREF} should be set to $17 \mu A$. Next, the setpoint voltages $V_{SETHIGH}$ and V_{SETLOW} are determined using the VPTAT scale factor of $5 mV/K = 5 mV/^{\circ}C + 273.15$, which is $1.49 V$ for $+25^{\circ}C$. Finally, the divider resistors are calculated, based on the setpoint voltages.

The setpoint voltages are calculated from the equation:

$$V_{SET} = (T_{SET} + 273.15)(5 mV/^{\circ}C)$$

This equation is used to calculate both the $V_{SETHIGH}$ and the V_{SETLOW} values. A simple 3-resistor network, as shown in Figure 18, determines the setpoints and hysteresis value. The equations used to calculate the resistors are:

$$R1 (k\Omega) = (V_{REF} - V_{SETHIGH})/I_{VREF} = (2.5 V - V_{SETHIGH})/I_{VREF}$$

$$R2 (k\Omega) = (V_{SETHIGH} - V_{SETLOW})/I_{VREF}$$

$$R3 (k\Omega) = V_{SETLOW}/I_{VREF}$$

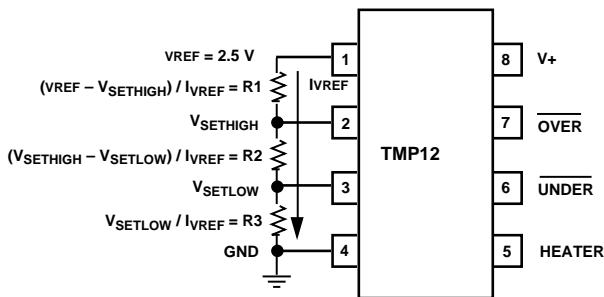

Figure 18. TMP12 Setpoint Programming

For example, setting the high setpoint for $+80^{\circ}C$, the low setpoint for $+55^{\circ}C$, and hysteresis for $3^{\circ}C$ produces the following values:

$$I_{HYS} = I_{VREF} = (3^{\circ}C \times 5 \mu A/^{\circ}C) + 7 \mu A = 15 \mu A + 7 \mu A = 22 \mu A$$

$$V_{SETHIGH} = (T_{SETHIGH} + 273.15)(5 mV/^{\circ}C) = (80^{\circ}C + 273.15)(5 mV/^{\circ}C) = 1.766 V$$

$$V_{SETLOW} = (T_{SETLOW} + 273.15)(5 mV/^{\circ}C) = (55^{\circ}C + 273.15)(5 mV/^{\circ}C) = 1.641 V$$

$$R1 (k\Omega) = (V_{REF} - V_{SETHIGH})/I_{VREF} = (2.5 V - 1.766 V)/22 \mu A = 33.36 k\Omega$$

$$R2 (k\Omega) = (V_{SETHIGH} - V_{SETLOW})/I_{VREF} = (1.766 V - 1.641 V)/22 \mu A = 5.682 k\Omega$$

$$R3 (k\Omega) = V_{SETLOW}/I_{VREF} = (1.641 V)/22 \mu A = 74.59 k\Omega$$

The total of $R1 + R2 + R3$ is equal to the load resistance needed to draw the desired hysteresis current from the reference, or I_{VREF} .

The nomograph of Figure 19 provides an easy method of determining the correct VPTAT voltage for any temperature. Simply locate the desired temperature on the appropriate scale (K, $^{\circ}C$ or $^{\circ}F$) and read the corresponding VPTAT value from the bottom scale.

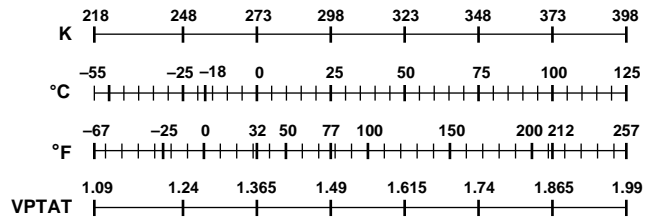

Figure 19. Temperature – VPTAT Scale

The formulas shown above are also helpful in understanding the calculations of temperature setpoint voltages in circuits other than the standard two-temperature thermal/airflow monitor. If a setpoint function is not needed, the appropriate comparator input should be disabled. SETHIGH can be disabled by tying it to $V+$ or V_{REF} , SETLOW by tying it to GND . Either output can be left disconnected.

Selecting Setpoints

Choosing the temperature setpoints for a given system is an empirical process, because of the wide variety of thermal issues in any practical design. The specific setpoints are dependent on such factors as airflow velocity in the system, adjacent component location and size, PCB thickness, location of copper ground planes, and thermal limits of the system.

The TMP12's temperature rise above ambient is proportional to airflow (Figures 1, 2 and 16). As a starting point, the low setpoint temperature could be set at the system ambient temperature (inside the enclosure) plus one half of the temperature rise above ambient (at the actual airflow in the system). With this setting, the low limit will provide a warning either if the fan output is reduced or if the ambient temperature rises (for example, if the fan's cool air intake is blocked). The high setpoint could then be set for the maximum system temperature to provide a final system shutdown control.

Measuring the TMP12 Internal Temperature

As previously mentioned, the TMP12's VPTAT generator represents the chip temperature with a slope of 5 mV/K. In some cases, selecting the setpoints is made easier if the TMP12's internal VPTAT voltage (and therefore the chip temperature) is known. For example, the case temperature of a high power microprocessor can be monitored with a thermistor, thermocouple, or other measurement method. The case temperature can then be correlated with the TMP12's temperature to select the setpoints.

The TMP12's VPTAT voltage is not available externally, so indirect methods must be used. Since the VPTAT voltage is applied to the internal comparators, measuring the voltage at which the digital output changes state will reflect the VPTAT voltage.

A simple method of measuring the TMP12 VPTAT is shown in Figure 20. To measure VPTAT, adjust potentiometer R1 until the LED turns ON. The voltage at Pin 2 of the TMP12 will then match the TMP12's internal VPTAT.

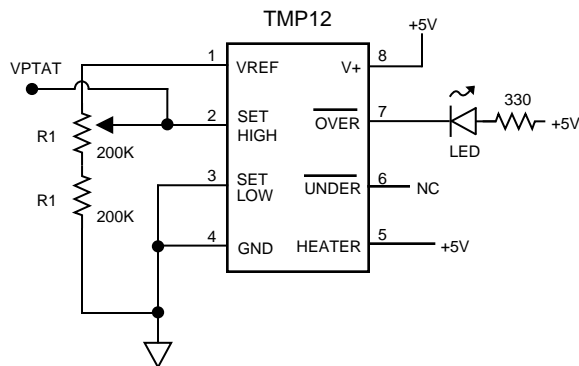

Figure 20. Measuring VPTAT with a Potentiometer

The method described in Figure 20 can be automated by replacing the discrete resistors with a digital potentiometer. The improved circuit, shown in Figure 21, permits the VPTAT voltage to be monitored with a microprocessor or other digital controller. The AD8402-100 provides two 100 kΩ potentiom-

eters which are adjusted to 8-bit resolution via a 3-wire serial interface. The controller simply sweeps the wiper of potentiometer 1 from the A1 terminal to the B1 terminal (digital value = 0), while monitoring the comparator output at Pin 7 of the TMP12. When Pin 7 goes low, the voltage at Pin 2 equals the VPTAT voltage. This circuit sweeps Pin 2's voltage from maximum to minimum, so that the TMP12's setpoint hysteresis will not affect the reading.

The circuit of Figure 21 provides approximately 1°C of resolution. The two potentiometers divide VREF by two, and the 8-bit potentiometer further divides VREF by 256, so the resolution is:

$$Resolution = \frac{\frac{VREF}{2}}{2^N} = \frac{\frac{2.5 V}{2}}{28} = 4.9 mV$$

where VREF is the voltage reference output (Pin 1 of the TMP12) and N is the resolution of the AD8402. Since the VPTAT has a slope of 5 mV/K, the AD8402 provides 1°C of resolution. The adjustment range of this circuit extends from VREF/2 (i.e. 1.25 V, or -23°C) to VREF - 1 LSB (i.e. 2.5 V - 4.9 mV, or 226°C). The VPTAT is therefore:

$$VPTAT = 1.25 V + (Digital Count \times 4.9 mV)$$

where Digital Count is the value sent to the AD8402 which caused the setpoint 1 output to go LOW.

A third way to measure the VPTAT voltage is to close a feedback loop around one of the TMP12's comparators. This causes the comparator to oscillate, and in turn forces the voltage at the comparator input to equal the VPTAT voltage. Figure 22 is a typical circuit for this measurement. An OP193 operational amplifier, operating as an integrator, provides additional loop-gain to ensure that the TMP12 comparator will oscillate.

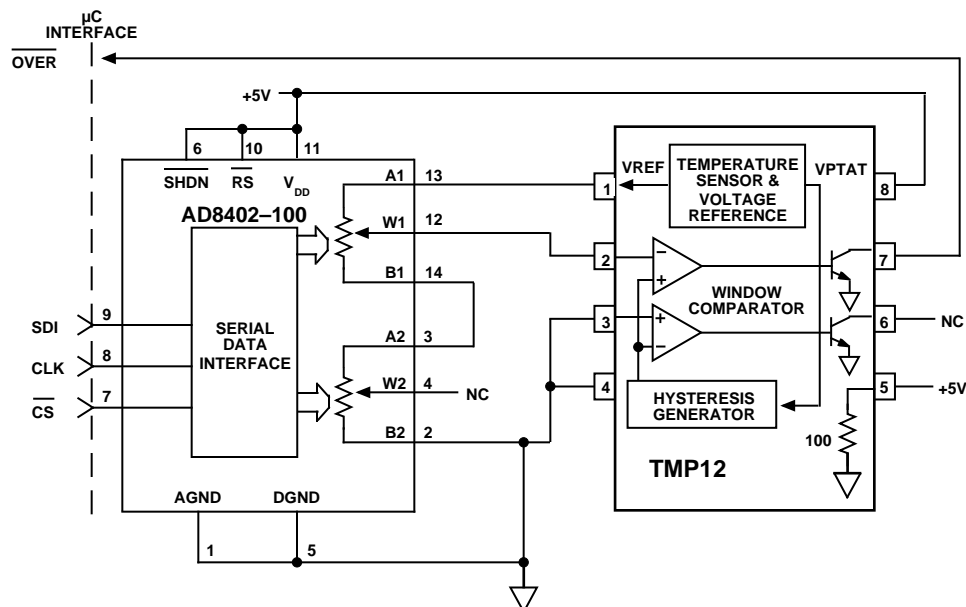

Figure 21. Measuring VPTAT with a Digital Potentiometer

TMP12

Understanding Error Sources

The accuracy of the VPTAT sensor output is well characterized and specified, however preserving this accuracy in a thermal monitoring control system requires some attention to minimizing the various potential error sources. The internal sources of setpoint programming error include the initial tolerances and temperature drifts of the reference voltage VREF, the setpoint comparator input offset voltage and bias current, and the hysteresis current scale factor. When evaluating setpoint programming errors, remember that any VREF error contribution at the comparator inputs is reduced by the resistor divider ratios. Each comparator's input bias current drops to less than 1 nA (typ) when the comparator is tripped. This change accounts for some setpoint voltage error, equal to the change in bias current multiplied by the effective setpoint divider ladder resistance to ground.

The thermal mass of the TMP12 package and the degree of thermal coupling to the surrounding circuitry are the largest factors in determining the rate of thermal settling, which ultimately determines the rate at which the desired temperature measurement accuracy may be reached (see graph in Figure 3). Thus, one must allow sufficient time for the device to reach the final temperature. The typical thermal time constant for the SOIC plastic package is approximately 70 seconds in still air. Therefore, to reach the final temperature accuracy within 1%, for a temperature change of 60 degrees, a settling time of 5 time constants, or 6 minutes, is necessary. Refer to Figure 4.

External error sources to consider are the accuracy of the external programming resistors, grounding error voltages, and thermal gradients. The accuracy of the external programming resistors directly impacts the resulting setpoint accuracy. Thus, in fixed-temperature applications the user should select resistor tolerances appropriate to the desired programming accuracy. Since setpoint resistors are typically located in the same air flow as the TMP12, resistor temperature drift must be taken into account also. This effect can be minimized by selecting good quality components, and by keeping all components in close thermal proximity. Careful circuit board layout and component placement are necessary to minimize common thermal error sources. Also, the user should take care to keep the bottom of the setpoint programming divider ladder as close to GND (Pin 4) as possible to minimize errors

due to IR voltage drops and coupling of external noise sources. In any case, a 0.1 μF capacitor for power supply bypassing is always recommended at the chip.

Safety Considerations in Heating and Cooling System Design

Designers should anticipate potential system fault conditions that may result in significant safety hazards which are outside the control of and cannot be corrected by the TMP12-based circuit. Governmental and Industrial regulations regarding safety requirements and standards for such designs should be observed where applicable.

Self-Heating Effects

In some applications the user should consider the effects of self-heating due to the power dissipated by the open-collector outputs, which are capable of sinking 20 mA continuously. Under full load, the TMP12 open-collector output device is dissipating:

$$P_{DISS} = 0.6 V \times 0.020 A = 12 mW$$

which in a surface-mount SO package accounts for a temperature increase due to self-heating of:

$$\Delta T = P_{DISS} \times \Theta_{JA} = 0.012 W \times 158^{\circ}\text{C}/W = 1.9^{\circ}\text{C}$$

This increase is for still air, of course, and will be reduced at high airflow levels. However, the user should still be aware that self-heating effects can directly affect the accuracy of the TMP12. For setpoint 2, self-heating will add to the setpoint temperature (that is, in the above example the TMP12 will switch the setpoint 2 output off 1.9 degrees early). Self-heating will not affect the temperature at which setpoint 1 turns on, but will add to the hysteresis. Several circuits for adding external driver transistors and other buffers are presented in following sections of this data sheet. These buffers will reduce self-heating and improve accuracy.

Buffering the Voltage Reference

The reference output VREF is used to generate the temperature setpoint programming voltages for the TMP12. Since the hysteresis is set by the reference current, external circuits which draw current from the reference will increase the hysteresis value.

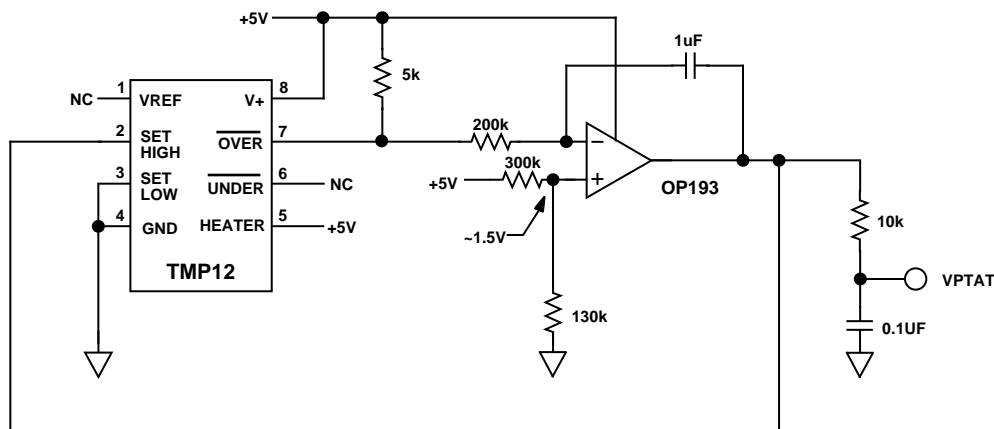

Figure 22. An Analog Measurement Circuit for VPTAT

The on-board VREF output buffer is typically capable of 500 μ A output drive into as much as 50 pF load (max). Exceeding this load will affect the accuracy of the reference voltage, could cause thermal sensing errors due to excess heat build-up, and may induce oscillations. External buffering of VREF with a low-drift voltage follower will ensure optimal reference accuracy. Amplifiers which offer low drift, low power consumption, and low cost appropriate to this application include the OP284, and members of the OP113 and OP193 families.

With excellent drift and noise characteristics, VREF offers a good voltage reference for data acquisition and transducer excitation applications as well. Output drift is typically better than -10 ppm/ $^{\circ}$ C, with 315 nV/Hz (typ) noise spectral density at 1 kHz.

Preserving Accuracy Over Wide Temperature Range Operation

The TMP12 is unique in offering both a wide-range temperature sensor and the associated detection circuitry needed to implement a complete thermostatic control function in one monolithic device. The voltage reference, setpoint comparators, and output buffer amplifiers have been carefully compensated to maintain accuracy over the specified temperature ranges in this application. Since the TMP12 is both sensor and control circuit, in many applications the external components used to program and interface the device are subjected to the same temperature extremes. Thus, it is necessary to place components in close thermal proximity minimizing large temperature differentials, and to account for thermal drift errors where appropriate, such as resistor matching temperature coefficients, amplifier error drift, and the like. Circuit design with the TMP12 requires a slightly different perspective regarding the thermal behavior of electronic components.

PC Board Layout Considerations

The TMP12 also requires a different perspective on PC board layout. In many applications, wide traces and generous ground planes are used to extract heat from components. The TMP12 is slightly different, in that ideal path for heat is via the cooling system air flow. Thus, heat paths through the PC traces should be minimized. This constraint implies that minimum pad sizes and trace widths should be specified in order to reduce heat conduction. At the same time, analog performance should not be compromised. In particular, the bottom of the setpoint resistor ladder should be located as close to GND as possible, as discussed in the Understanding Error Sources section of this data sheet.

Thermal Response Time

The time required for a temperature sensor to settle to a specified accuracy is a function of the thermal mass of the sensor, and the thermal conductivity between the sensor and the object being sensed. Thermal mass is often considered equivalent to capacitance. Thermal conductivity is commonly specified using the symbol Q , and is the inverse of thermal resistance. It is commonly specified in units of degrees per watt of power transferred across the thermal joint. Figures 3 and 5 illustrate the typical RC time constant response to a step change in ambient temperature. Thus, the time required for the TMP12 to settle to the desired accuracy is dependent on the package selected, the thermal contact established in the particular application, and the equivalent thermal conductivity of the heat source. For most applications, the settling-time is probably best determined empirically.

Switching Loads with the Open-Collector Outputs

In many temperature sensing and control applications some type of switching is required. Whether it be to turn on a heater when the temperature goes below a minimum value or to turn off a motor that is overheating, the open-collector outputs can be used. For the majority of applications, the switches used need to handle large currents on the order of 1 Amp and above. Because the TMP12 is accurately measuring temperature, the open-collector outputs should handle less than 20 mA of current to minimize self-heating. Clearly, the trip point outputs should not drive the equipment directly. Instead, an external switching device is required to handle the large currents. Some examples of these are relays, power MOSFETs, thyristors, IGBTs, and Darlington transistors.

This section shows a variety of circuits where the TMP12 controls a switch. The main consideration in these circuits, such as the relay in Figure 23, is the current required to activate the switch.

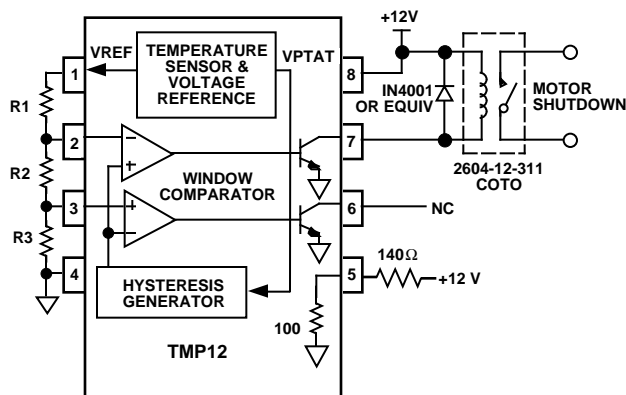
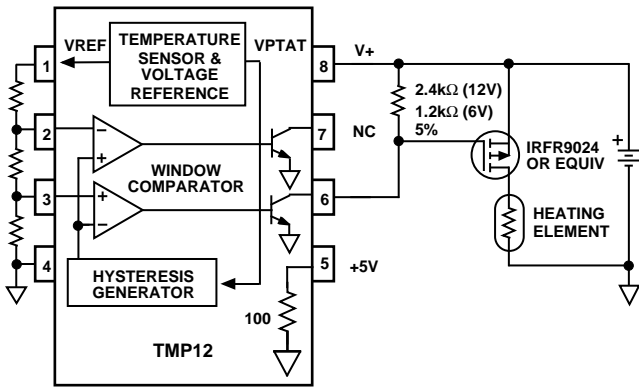

Figure 23. Reed Relay Drive

It is important to check the particular relay you choose to ensure that the current needed to activate the coil does not exceed the TMP12's recommended output current of 20 mA. This is easily determined by dividing the relay coil voltage by the specified coil resistance. Keep in mind that the inductance of the relay will create large voltage spikes that can damage the TMP12 output unless protected by a commutation diode across the coil, as shown. The relay shown has contact rating of 10 Watts maximum. If a relay capable of handling more power is desired, the larger contacts will probably require a commensurably larger coil, with lower coil resistance and thus higher trigger current. As the contact power handling capability increases, so does the current needed for the coil. In some cases an external driving transistor should be used to remove the current load on the TMP12 as explained in the next section.

TMP12

Power FETs are popular for handling a variety of high current dc loads. Figure 24 shows the TMP12 driving a P-channel MOSFET transistor for a simple heater circuit. When the output transistor turns on, the gate of the MOSFET is pulled down to approximately 0.6 V, turning it on. For most MOSFETs a gate-to-source voltage or V_{gs} on the order of -2 V to -5 V is sufficient to turn the device on. Figure 25 shows a similar circuit for turning on an N-channel MOSFET, except that now the gate to source voltage is positive. For this reason an external transistor must be used as an inverter so that the MOSFET will turn on when the trip point pulls down.



NC = NO CONNECT

Figure 24. Driving a P-Channel MOSFET

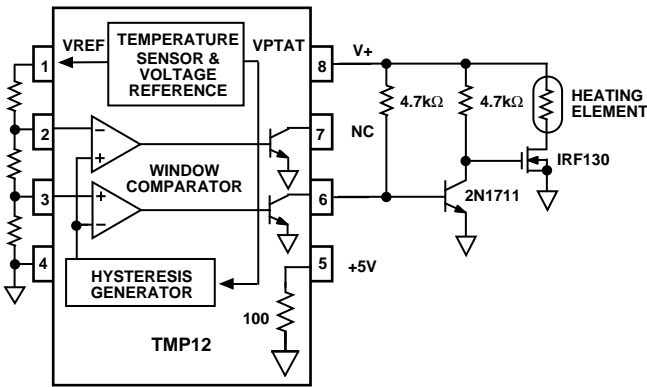

Figure 25. Driving an N-Channel MOSFET

Isolated Gate Bipolar Transistors (IGBTs) combine many of the benefits of power MOSFETs with bipolar transistors and are used for a variety of high power applications. Because IGBTs have a gate similar to MOSFETs, turning on and off the devices is relatively simple as shown in Figure 26. The turn on voltage for the IGBT shown (IRGB40S) is between 3.0 and 5.5 volts. This part has a continuous collector current rating of 50 A and a maximum collector to emitter voltage of 600 V, enabling it to work in very demanding applications.

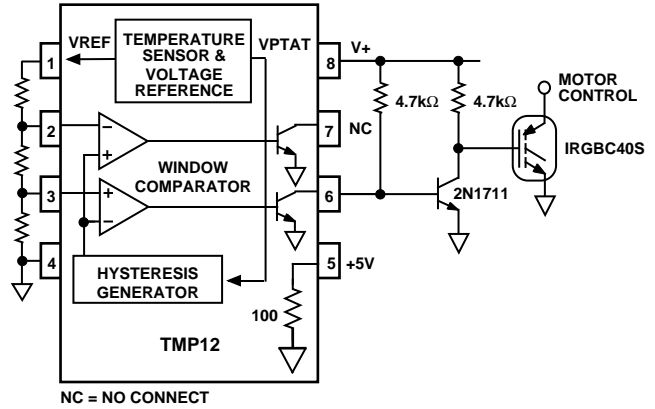

Figure 26. Driving an IGBT

The last class of high power devices discussed here are Thyristors, which include SCRs and Triacs. Triacs are a useful alternative to relays for switching ac line voltages. The 2N6073A shown in Figure 27 is rated to handle 4 A (rms). The opto-isolated MOC3011 Triac shown features excellent electrical isolation from the noisy ac line and complete control over the high power Triac with only a few additional components.

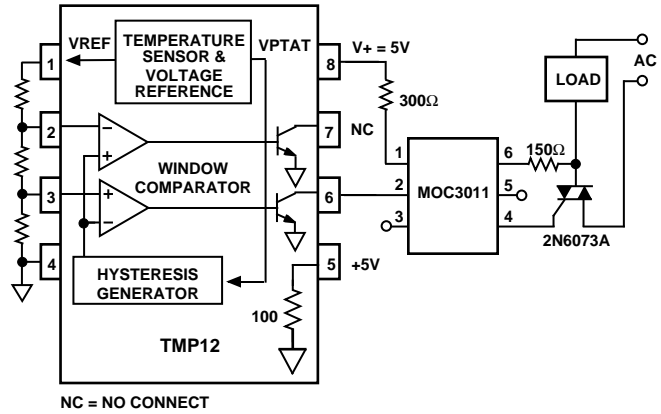

Figure 27. Controlling the 2N6073A Triac

High Current Switching

As mentioned earlier, internal dissipation due to large loads on the TMP12 outputs will cause some temperature error due to self-heating. External transistors buffer the load from the TMP12 so that virtually no power is dissipated in the internal transistors and minimal self-heating occurs. This section shows several examples using external transistors. The simplest case uses a single transistor on the output to invert the output signal is shown in Figure 28. When the open-collector of the TMP12 turns "ON" and pulls the output down, the external transistor Q1's base will be pulled low, turning off the transistor. Another transistor can be added to re-invert the signal as shown in Figure 29. Now, when the output of the TMP12 is pulled down, the first transistor, Q1, turns off and its collector goes high, which turns Q2 on, pulling its collector low. Thus, the output taken from the collector of Q2 is identical to the output of the TMP12. By picking a transistor that can accommodate large amounts of current, many high power devices can be switched.

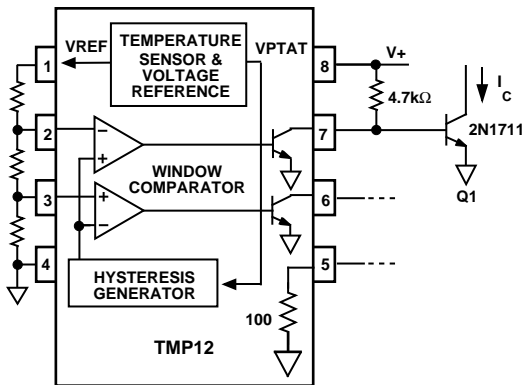

Figure 28. An External Transistor Minimizes Self-Heating

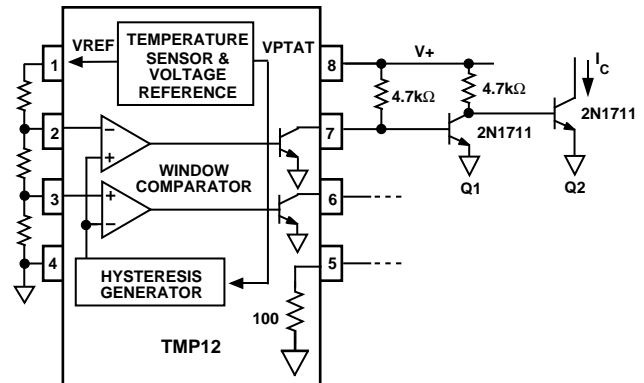

Figure 29. Second Transistor Maintains Polarity of TMP12 Output

An example of a higher power transistor is a standard Darlington configuration as shown in Figure 30. The part chosen, TIP-110, can handle 2 A continuous which is more than enough to control many high power relays. In fact the Darlington itself can be used as the switch, similar to MOSFETs and IGBTs.

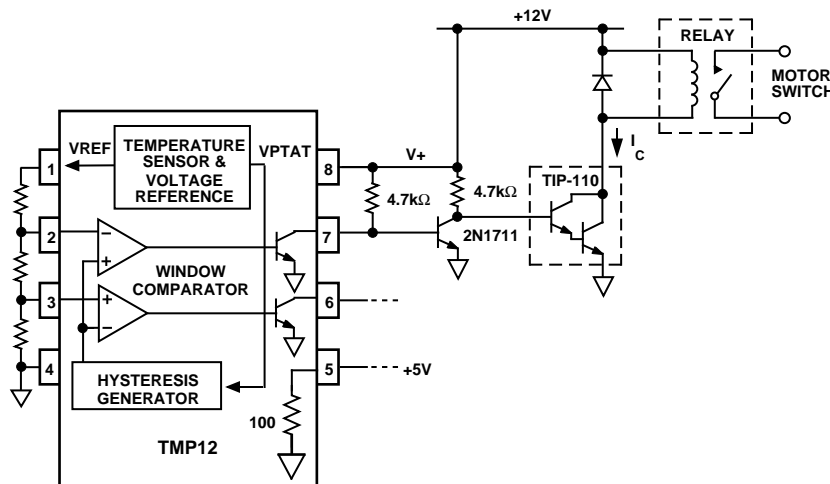

Figure 30. Darlington Transistor Can Handle Large Currents

