

**TMS27C040 524288 BY 8-BIT UV-ERASABLE**  
**TMS27PC040 524288 BY 8-BIT**  
**PROGRAMMABLE READ-ONLY MEMORY**  
 SMLS040F – NOVEMBER 1990 – REVISED SEPTEMBER 1997

- Organization . . . 524288 by 8 Bits
- Single 5-V Power Supply
- Industry Standard 32-Pin Dual In-Line Package and 32-Lead Plastic Leaded Chip Carrier
- All Inputs/Outputs Fully TTL Compatible
- Static Operation (No Clocks, No Refresh)
- Max Access/Min Cycle Time  
 $V_{CC} \pm 10\%$   
 '27C/PC040-10 100 ns  
 '27C/PC040-12 120 ns  
 '27C/PC040-15 150 ns
- 8-Bit Output For Use in Microprocessor-Based Systems
- Power-Saving CMOS Technology
- 3-State Output Buffers
- 400-mV Assured DC Noise Immunity With Standard TTL Loads
- Latchup Immunity of 250 mA on All Input and Output Pins
- No Pullup Resistors Required
- Low Power Dissipation ( $V_{CC} = 5.5\text{ V}$ )  
 – Active . . . 275 mW Worst Case  
 – Standby . . . 0.55 mW Worst Case  
 (CMOS-Input Levels)
- Temperature Range Options

**description**

The TMS27C040 devices are 524288 by 8-bit (4194304-bit), ultraviolet (UV) light erasable, electrically programmable read-only memories (EPROMs).

The TMS27PC040 devices are 524288 by 8-bit (4194304-bit), one-time programmable (OTP) electrically programmable read-only memories (PROMs).

These devices are fabricated using CMOS technology for high speed and simple interface with MOS and bipolar circuits. All inputs (including program data inputs) can be driven by the Series 74 TTL circuits. Each output can drive one Series 74 TTL circuit without external resistors.

**TMS27C040**  
**J PACKAGE**  
 (TOP VIEW)

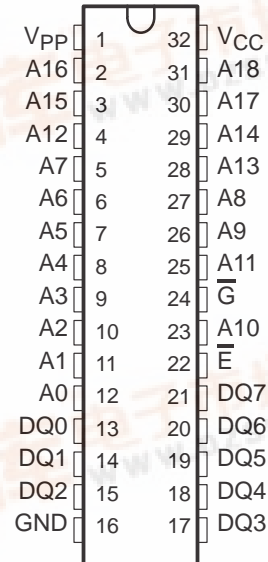

**TMS27PC040**  
**FM PACKAGE**  
 (TOP VIEW)

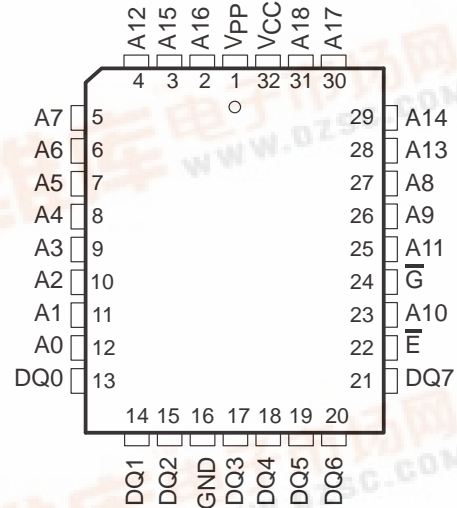

PIN NOMENCLATURE	
A0–A18	Address Inputs
DQ0–DQ7	Inputs (programming)/Outputs
$\bar{E}$	Chip Enable
$\bar{G}$	Output Enable
GND	Ground
VCC	5-V Supply
VPP	13-V Power Supply†

† Only in program mode.

Please be aware that an important notice concerning availability, standard warranty, and use in critical applications of Texas Instruments semiconductor products and disclaimers thereto appears at the end of this data sheet.

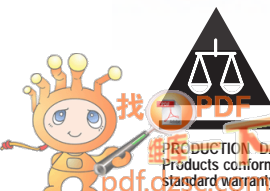

# TMS27C040 524288 BY 8-BIT UV ERASABLE TMS27PC040 524288 BY 8-BIT PROGRAMMABLE READ-ONLY MEMORY

SMLS040F – NOVEMBER 1990 – REVISED SEPTEMBER 1997

## description (continued)

The data outputs are 3-state for connecting multiple devices to a common bus

The TMS27C040 is offered in a 600-mil ceramic dual-in-line package (J suffix). The TMS27C040 is offered with two choices of temperature ranges of 0°C to 70°C (JL suffix) and –40°C to 85°C (JE suffix). (See Table 1.)

The TMS27PC040 is offered in a 32-lead plastic leaded chip carrier package (FM suffix). The TMS27PC040 is offered with two choices of temperature ranges of 0°C to 70°C (JL suffix) and –40°C to 85°C (JE suffix).

**Table 1. Temperature Range Suffixes**

FUNCTION	SUFFIX FOR OPERATING FREE-AIR TEMPERATURE RANGES	
	0°C to 70°C	–40°C to 85°C
TMS27C040-XXX	JL	JE
TMS27PC040-XXX	FML	FME

These EPROMs and PROMS operate from a single 5-V supply (in the read mode), and they are ideal for use in microprocessor-based systems. One other (13 V) supply is needed for programming. All programming signals are TTL level. For programming outside the system, existing EPROM programmers can be used.

## operation

The seven modes of operation are listed in Table 2. The read mode requires a single 5-V supply. All inputs are TTL level except for  $V_{PP}$  during programming (13 V), and  $V_H$  (12 V) on A9 for the signature mode.

**Table 2. Operation Modes**

MODE	FUNCTION†						
	$\bar{E}$	$\bar{G}$	$V_{PP}$	$V_{CC}$	A9	A0	DQ0–DQ7
Read	$V_{IL}$	$V_{IL}$	X	$V_{CC}$	X	X	Data Out
Output Disable	$V_{IL}$	$V_{IH}$	$V_{CC}$	$V_{CC}$	X	X	Hi-Z
Standby	$V_{IH}$	X	$V_{CC}$	$V_{CC}$	X	X	Hi-Z
Programming	$V_{IL}$	$V_{IH}$	$V_{PP}$	$V_{CC}$	X	X	Data In
Program Inhibit	$V_{IH}$	$V_{IH}$	$V_{PP}$	$V_{CC}$	X	X	Hi-Z
Verify	$V_{IH}$	$V_{IL}$	$V_{PP}$	$V_{CC}$	X	X	Data Out
Signature Mode	$V_{IL}$	$V_{IL}$	$V_{CC}$	$V_{CC}$	$V_H‡$	$V_{IL}$	MFG Code 97
						$V_{IH}$	Device Code 50

† X can be  $V_{IL}$  or  $V_{IH}$

‡  $V_H = 12 V \pm 0.5 V$

## read/output disable

When the outputs of two or more TMS27C040s or TMS27PC040s are connected in parallel on the same bus, the output of any particular device in the circuit can be read with no interference from competing outputs of the other devices. To read the output of a single device, a low level signal is applied to the  $\bar{E}$  and  $\bar{G}$  pins. All other devices in the circuit should have their outputs disabled by applying a high level signal to one of these pins.

## latchup immunity

Latchup immunity on the TMS27C040 and TMS27PC040 is a minimum of 250 mA on all inputs and outputs. This feature provides latchup immunity beyond any potential transients at the P.C. board level when the EPROM is interfaced to industry standard TTL or MOS logic devices. The input/output layout approach controls latchup without compromising performance or packing density.

**TMS27C040 524288 BY 8-BIT UV ERASABLE**  
**TMS27PC040 524288 BY 8-BIT**  
**PROGRAMMABLE READ-ONLY MEMORY**  
SMLS040F – NOVEMBER 1990 – REVISED SEPTEMBER 1997

**power down**

Active I<sub>CC</sub> supply current can be reduced from 50 mA to 1 mA by applying a high TTL input on  $\bar{E}$  and to 100  $\mu$ A by applying a high CMOS input on  $\bar{E}$ . In this mode all outputs are in the high-impedance state.

**erasure (TMS27C040)**

Before programming, the TMS27C040 EPROM is erased by exposing the chip through the transparent lid to a high intensity UV-light (wavelength 2537 Å). The recommended minimum exposure dose (UV intensity  $\times$  exposure time) is 15-W·s/cm<sup>2</sup>. A typical 12-mW/cm<sup>2</sup>, filterless UV lamp erases the device in 21 minutes. The lamp must be located about 2.5 cm above the chip during erasure. After erasure, all bits are in the high state. Normal ambient light contains the correct wavelength for erasure; therefore, when using the TMS27C040, the window must be covered with an opaque label. After erasure (all bits in logic high state), logic lows are programmed into the desired locations. A programmed low can be erased only by UV light.

**initializing (TMS27PC040)**

The OTP TMS27PC040 PROM is provided with all bits in logic high state, then logic lows are programmed into the desired locations. Logic lows programmed into an OTP PROM cannot be erased.

**SNAP! Pulse programming**

The TMS27C040 and TMS27PC040 are programmed by using the SNAP! Pulse programming algorithm. The programming sequence is shown in the SNAP! Pulse programming flow chart shown in Figure 1.

The initial setup is V<sub>PP</sub> = 13 V, V<sub>CC</sub> = 6.5 V,  $\bar{E} = V_{IH}$ , and  $\bar{G} = V_{IH}$ . Once the initial location is selected, the data is presented in parallel (eight bits) on pins DQ0 through DQ7. Once addresses and data are stable, the programming mode is achieved when  $\bar{E}$  is pulsed low (V<sub>IL</sub>) with a pulse duration of t<sub>w(PGM)</sub>. Every location is programmed only once before going to interactive mode.

In the interactive mode, the word is verified at V<sub>PP</sub> = 13 V, V<sub>CC</sub> = 6.5 V,  $\bar{E} = V_{IH}$ , and  $\bar{G} = V_{IL}$ . If the correct data is not read, the programming is performed by pulling  $\bar{E}$  low with a pulse duration of t<sub>w(PGM)</sub>. This sequence of verification and programming is performed up to a maximum of 10 times. When the device is fully programmed, all bytes are verified with V<sub>CC</sub> = V<sub>PP</sub> = 5 V  $\pm$  10%.

**program inhibit**

Programming can be inhibited by maintaining high level inputs on the  $\bar{E}$  and  $\bar{G}$  pins.

**program verify**

Programmed bits can be verified with V<sub>PP</sub> = 13 V when  $\bar{G} = V_{IL}$ , and  $\bar{E} = V_{IH}$ .

**signature mode**

The signature mode provides access to a binary code identifying the manufacturer and type. This mode is activated when A9 (pin 26) is forced to 12 V. Two identifier bytes are accessed by toggling A0. All other addresses must be held low. The signature code for the TMS27C040 is 9750. A0 low selects the manufacturer's code 97 (Hex), and A0 high selects the device code 50 (Hex), as shown in Table 3.

**Table 3. Signature Mode**

IDENTIFIERT	PINS									
	A0	DQ7	DQ6	DQ5	DQ4	DQ3	DQ2	DQ1	DQ0	HEX
MANUFACTURER CODE	V <sub>IL</sub>	1	0	0	1	0	1	1	1	97
DEVICE CODE	V <sub>IH</sub>	0	1	0	1	0	0	0	0	50

†  $\bar{E} = \bar{G} = V_{IL}$ , A1-A8 = V<sub>IL</sub>, A9 = V<sub>H</sub>, A10-A18 = V<sub>IL</sub>, V<sub>PP</sub> = V<sub>CC</sub>.

TMS27C040 524288 BY 8-BIT UV ERASABLE  
TMS27PC040 524288 BY 8-BIT  
PROGRAMMABLE READ-ONLY MEMORY  
SMLS040F – NOVEMBER 1990 – REVISED SEPTEMBER 1997

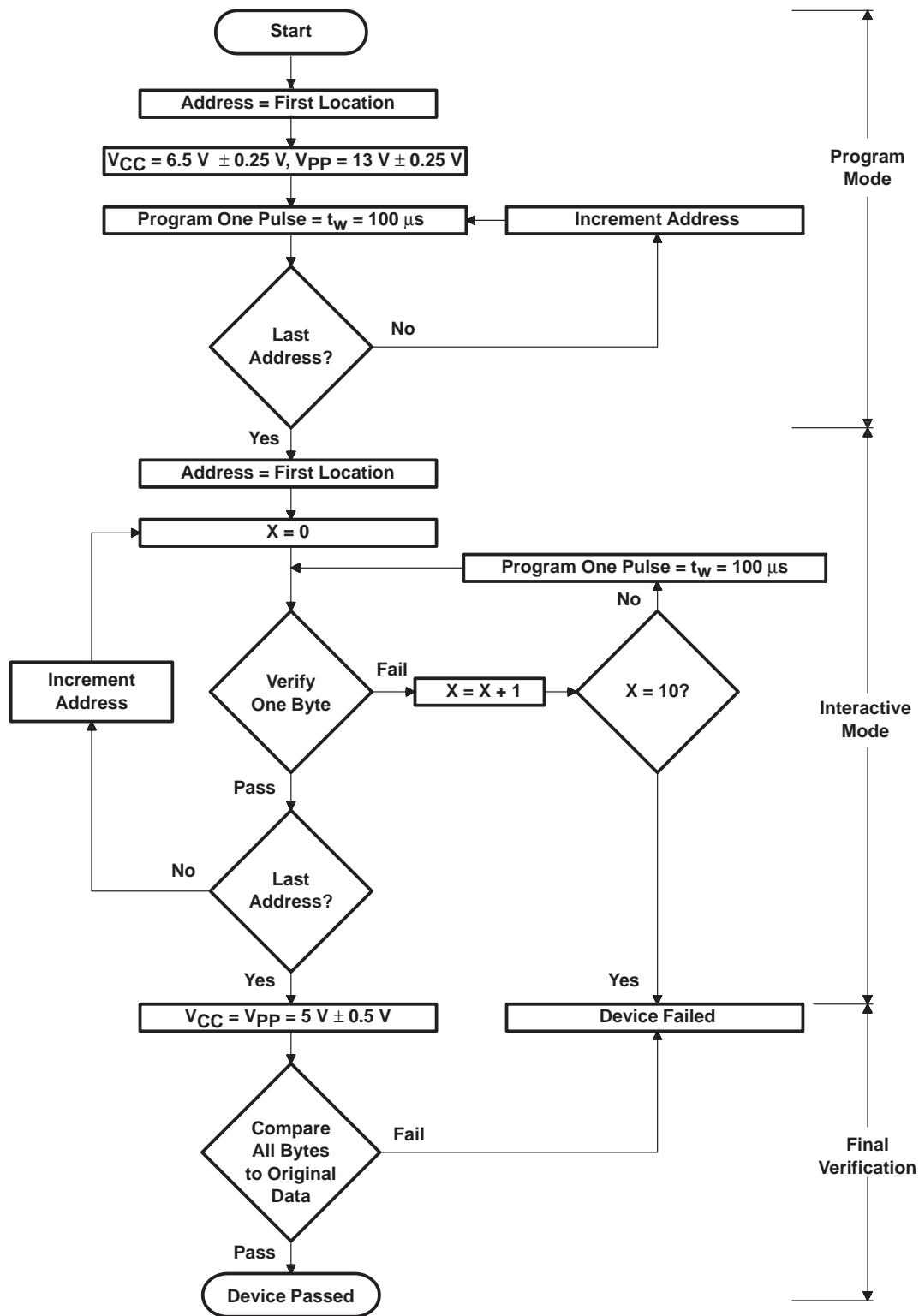

Figure 1. SNAP! Pulse Programming Flow Chart



**TMS27C040 524288 BY 8-BIT UV ERASABLE  
TMS27PC040 524288 BY 8-BIT  
PROGRAMMABLE READ-ONLY MEMORY**

SMLS040F – NOVEMBER 1990 – REVISED SEPTEMBER 1997

**recommended operating conditions**

		MIN	NOM	MAX	UNIT		
V <sub>CC</sub>	Supply voltage	Read mode (see Note 2)		4.5	5	5.5	V
		SNAP! Pulse programming algorithm		6.25	6.5	6.75	V
V <sub>PP</sub>	Supply voltage	Read mode		V <sub>CC</sub> - 0.6	V <sub>CC</sub> + 0.6		V
		SNAP! Pulse programming algorithm		12.75	13	13.25	V
V <sub>IH</sub>	High-level dc input voltage	TTL		2	V <sub>CC</sub> + 0.5		V
		CMOS		V <sub>CC</sub> - 0.2	V <sub>CC</sub> + 0.5		V
V <sub>IL</sub>	Low-level dc input voltage	TTL		-0.5	0.8		V
		CMOS		-0.5	0.2		V
T <sub>A</sub>	Operating free-air temperature	'27C040-__JL '27PC040-__FML		0	70		°C
T <sub>A</sub>	Operating free-air temperature	'27C040-__JE		-40	85		°C

NOTE 2: V<sub>CC</sub> must be applied before or at the same time as V<sub>PP</sub> and removed after or at the same time as V<sub>PP</sub>. The device must not be inserted into or removed from the board when V<sub>PP</sub> or V<sub>CC</sub> is applied.

**electrical characteristics over recommended ranges of supply voltage and operating free-air temperature**

PARAMETER		TEST CONDITIONS	MIN	MAX	UNIT	
V <sub>OH</sub>	High-level dc output voltage	I <sub>OH</sub> = -400 μA	2.4		V	
		I <sub>OH</sub> = -20 μA	V <sub>CC</sub> - 0.1			
V <sub>OL</sub>	Low-level dc output voltage	I <sub>OL</sub> = 2.1 mA	0.4		V	
		I <sub>OL</sub> = 20 μA	0.1			
I <sub>I</sub>	Input current (leakage)	V <sub>I</sub> = 0 V to 5.5 V	±1		μA	
I <sub>O</sub>	Output current (leakage)	V <sub>O</sub> = 0 V to V <sub>CC</sub>	±1		μA	
I <sub>PP1</sub>	V <sub>PP</sub> supply current	V <sub>PP</sub> = V <sub>CC</sub> = 5.5 V	10		μA	
I <sub>PP2</sub>	V <sub>PP</sub> supply current (during program pulse)	V <sub>PP</sub> = 12.75 V	50		mA	
I <sub>CC1</sub>	V <sub>CC</sub> supply current (standby)	TTL-Input level	V <sub>CC</sub> = 5.5 V, $\bar{E} = V_{IH}$		1	mA
		CMOS-Input level	V <sub>CC</sub> = 5.5 V, $\bar{E} = V_{CC}$		100	μA
I <sub>CC2</sub>	V <sub>CC</sub> supply current (active)	$\bar{E} = V_{IL}$ , V <sub>CC</sub> = 5.5 V t <sub>cycle</sub> = minimum cycle time, outputs open†	50		mA	

† Minimum cycle time = maximum access time.

**capacitance over recommended ranges of supply voltage and operating free-air temperature, f = 1 MHz‡**

PARAMETER		TEST CONDITIONS	MIN	TYP <sup>§</sup>	MAX	UNIT
C <sub>i</sub>	Input capacitance	V <sub>I</sub> = 0 V	4		8	pF
C <sub>o</sub>	Output capacitance	V <sub>O</sub> = 0 V	8		12	pF

‡ All typical values are at T<sub>A</sub> = 25°C and nominal voltages.

§ Capacitance measurements are made on sample basis only.

**TMS27C040 524288 BY 8-BIT UV ERASABLE  
TMS27PC040 524288 BY 8-BIT  
PROGRAMMABLE READ-ONLY MEMORY**  
SMLS040F – NOVEMBER 1990 – REVISED SEPTEMBER 1997

**switching characteristics over recommended ranges of operating conditions (see Notes 3 and 4)**

PARAMETER	TEST CONDITIONS	'27C040-10 '27PC040-10		'27C040-12 '27PC040-12		'27C040-15 '27PC040-15		UNIT	
		MIN	MAX	MIN	MAX	MIN	MAX		
$t_{a(A)}$ Access time from address	$C_L = 100$ pF, 1 Series 74 TTL load, Input $t_r \leq 20$ ns, Input $t_f \leq 20$ ns		100		120		150	ns	
$t_{a(E)}$ Access time from chip enable			100		120		150	ns	
$t_{en(G)}$ Output enable time from $\overline{G}$			50		50		50	ns	
$t_{dis}$ Output disable time from $\overline{G}$ or $\overline{E}$ , whichever occurs first			0	50	0	50	0	50	ns
$t_{v(A)}$ Output data valid time after change of address, $\overline{E}$ , or $\overline{G}$ , whichever occurs first†			0		0		0		ns

† Value calculated from 0.5-V delta to measured output level.

- NOTES: 3. For all switching characteristics the input pulse levels are 0.4 V to 2.4 V. Timing measurements are made at 2 V for logic high and 0.8 V for logic low. (See Figure 2)
4. Common test conditions apply for  $t_{dis}$  except during programming.

**switching characteristics for programming:  $V_{CC} = 6.5$  V and  $V_{PP} = 13$  V (SNAP! Pulse),  $T_A = 25^\circ\text{C}$  (see Note 3)**

PARAMETER	MIN	MAX	UNIT
$t_{dis(G)}$ Output disable time from $\overline{G}$	0	100	ns
$t_{en(G)}$ Output enable time from $\overline{G}$		150	ns

NOTE 3: For all switching characteristics the input pulse levels are 0.4 V to 2.4 V. Timing measurements are made at 2 V for logic high and 0.8 V for logic low. (See Figure 2)

**timing requirements for programming**

	MIN	NOM	MAX	UNIT		
$t_{w(PGM)}$ Pulse duration, program	SNAP! Pulse programming algorithm		95	100	105	$\mu\text{s}$
$t_{su(A)}$ Setup time, address	2			$\mu\text{s}$		
$t_{su(E)}$ Setup time, $\overline{E}$	2			$\mu\text{s}$		
$t_{su(G)}$ Setup time, $\overline{G}$	2			$\mu\text{s}$		
$t_{su(D)}$ Setup time, data	2			$\mu\text{s}$		
$t_{su(VPP)}$ Setup time, $V_{PP}$	2			$\mu\text{s}$		
$t_{su(VCC)}$ Setup time, $V_{CC}$	2			$\mu\text{s}$		
$t_h(A)$ Hold time, address	0			$\mu\text{s}$		
$t_h(D)$ Hold time, data	2			$\mu\text{s}$		

**TMS27C040 524288 BY 8-BIT UV ERASABLE  
TMS27PC040 524288 BY 8-BIT  
PROGRAMMABLE READ-ONLY MEMORY**  
SMLS040F – NOVEMBER 1990 – REVISED SEPTEMBER 1997

**PARAMETER MEASUREMENT INFORMATION**

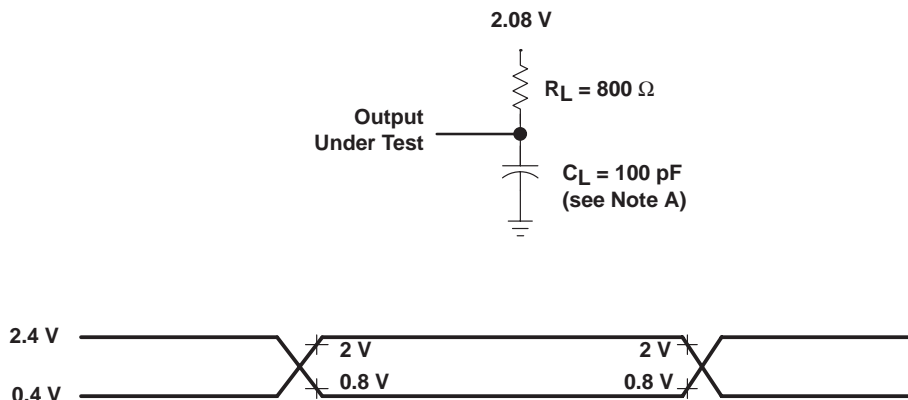

- NOTES: A.  $C_L$  includes probe and fixture capacitance.  
B. AC testing inputs are driven at 2.4 V for logic high and 0.4 V for logic low. Timing measurements are made at 2 V for logic high and 0.8 V for logic low for both inputs and outputs.

**Figure 2. AC Testing Output Load Circuit and Waveform**

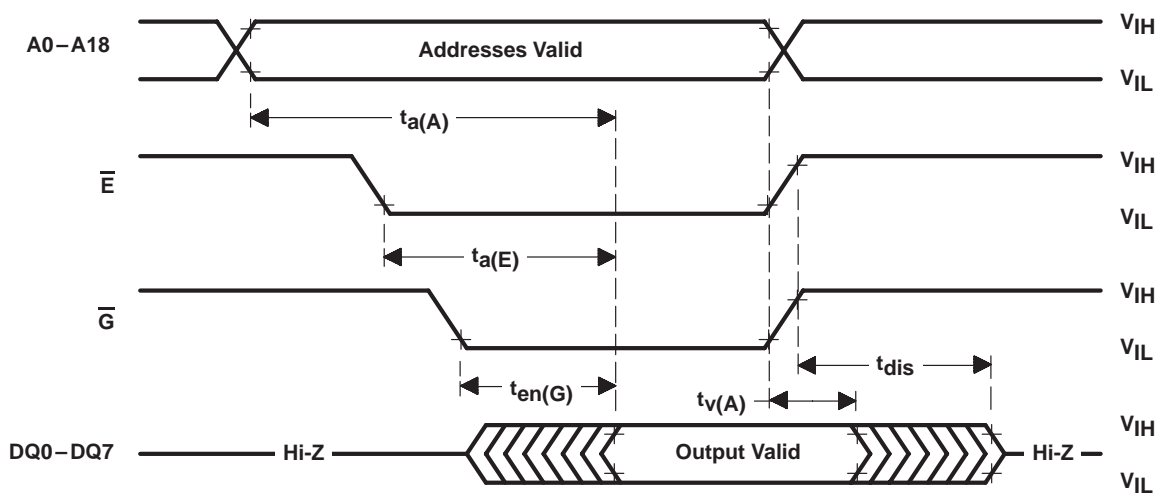
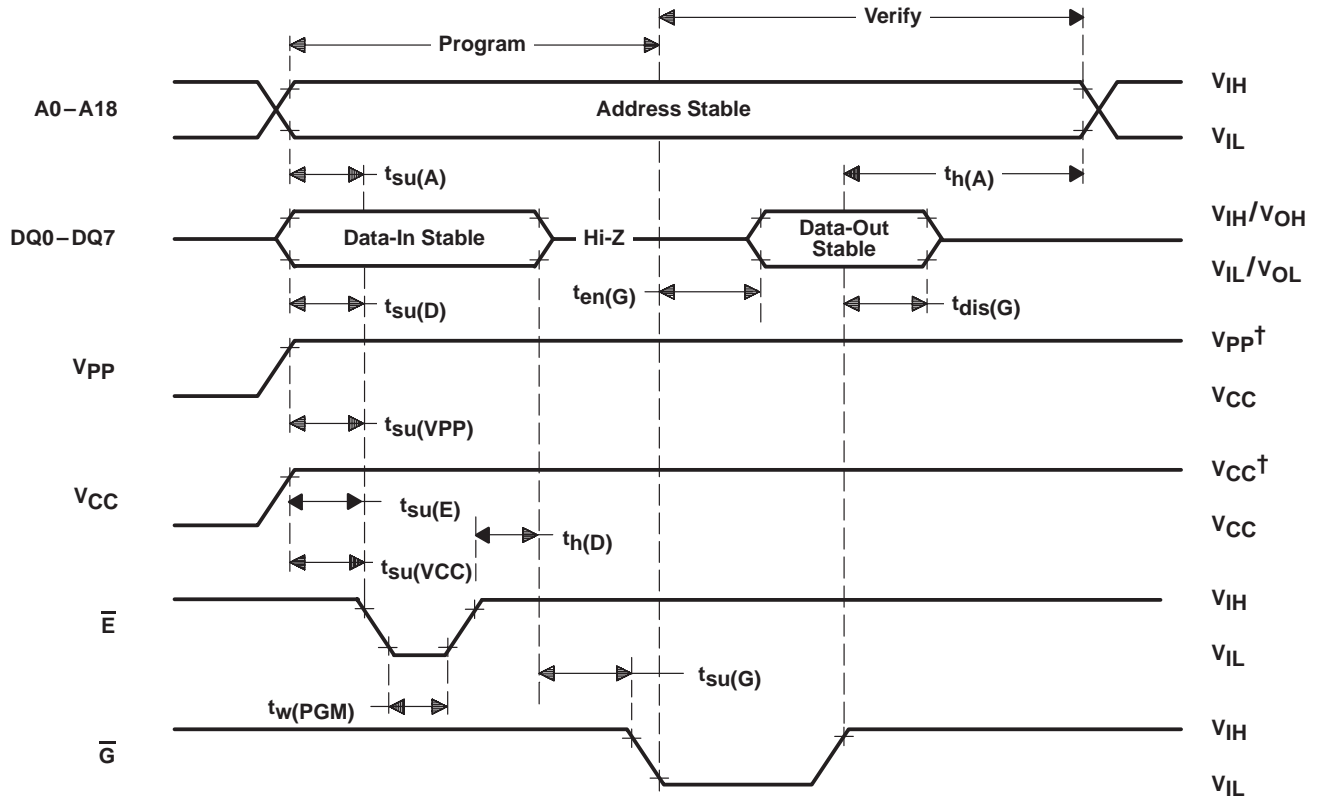

**Figure 3. Read-Cycle Timing**



TMS27C040 524288 BY 8-BIT UV ERASABLE  
TMS27PC040 524288 BY 8-BIT  
PROGRAMMABLE READ-ONLY MEMORY  
SMLS040F – NOVEMBER 1990 – REVISED SEPTEMBER 1997

PARAMETER MEASUREMENT INFORMATION



† 13-V  $V_{PP}$  and 6.5-V  $V_{CC}$  for SNAP! Pulse programming

Figure 4. Program-Cycle Timing (SNAP! Pulse Programming)

**TMS27C040 524288 BY 8-BIT UV ERASABLE  
TMS27PC040 524288 BY 8-BIT  
PROGRAMMABLE READ-ONLY MEMORY**

SMLS040F – NOVEMBER 1990 – REVISED SEPTEMBER 1997

FM (R-PQCC-J32)

PLASTIC J-LEADED CHIP CARRIER

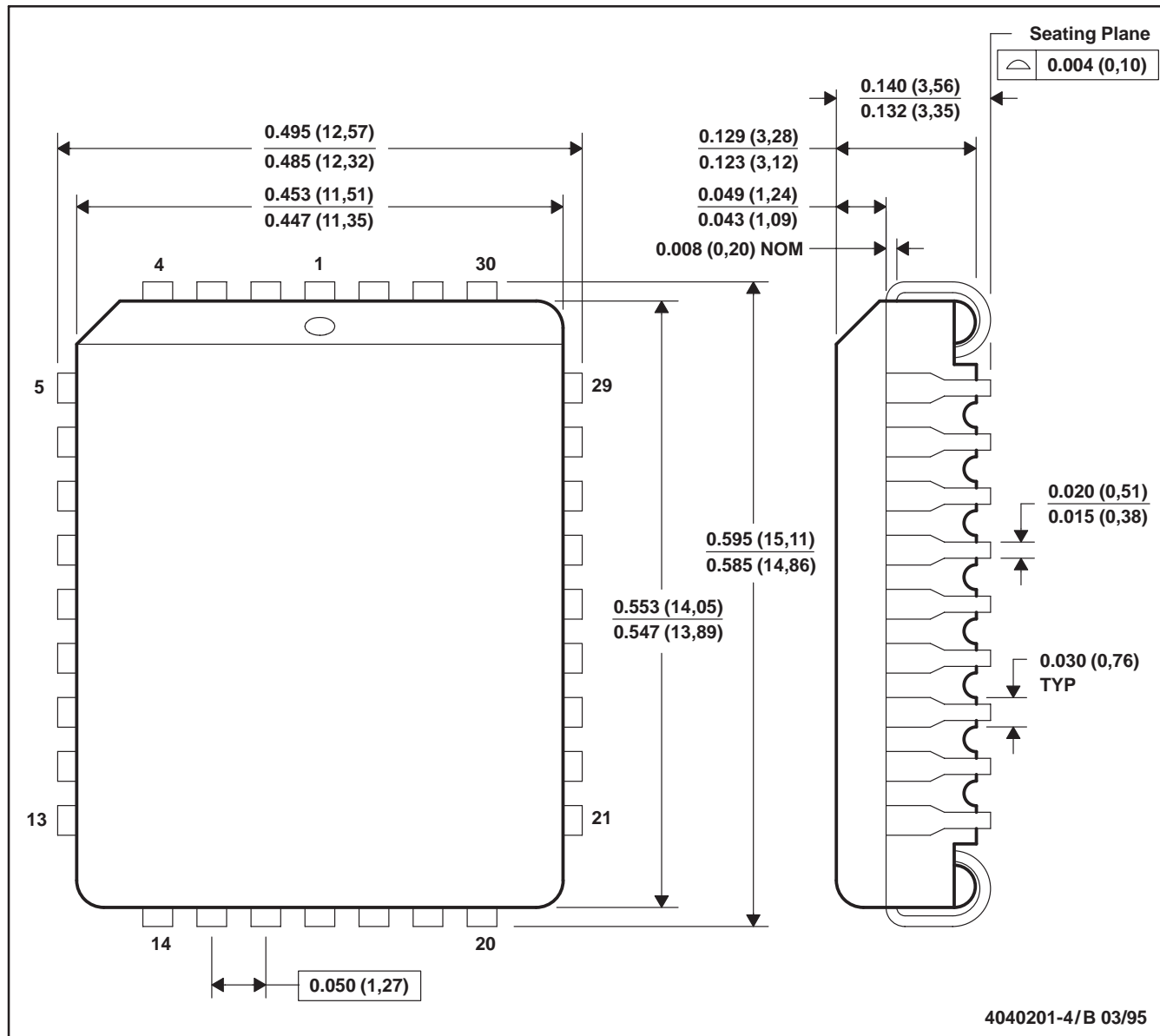

- NOTES: A. All linear dimensions are in inches (millimeters).  
B. This drawing is subject to change without notice.  
C. Falls within JEDEC MS-016

**TMS27C040 524288 BY 8-BIT UV ERASABLE  
TMS27PC040 524288 BY 8-BIT  
PROGRAMMABLE READ-ONLY MEMORY**  
SMLS040F – NOVEMBER 1990 – REVISED SEPTEMBER 1997

**J (R-CDIP-T\*\*)**

**CERAMIC SIDE-BRAZE DUAL-IN-LINE PACKAGE**

24 PIN SHOWN

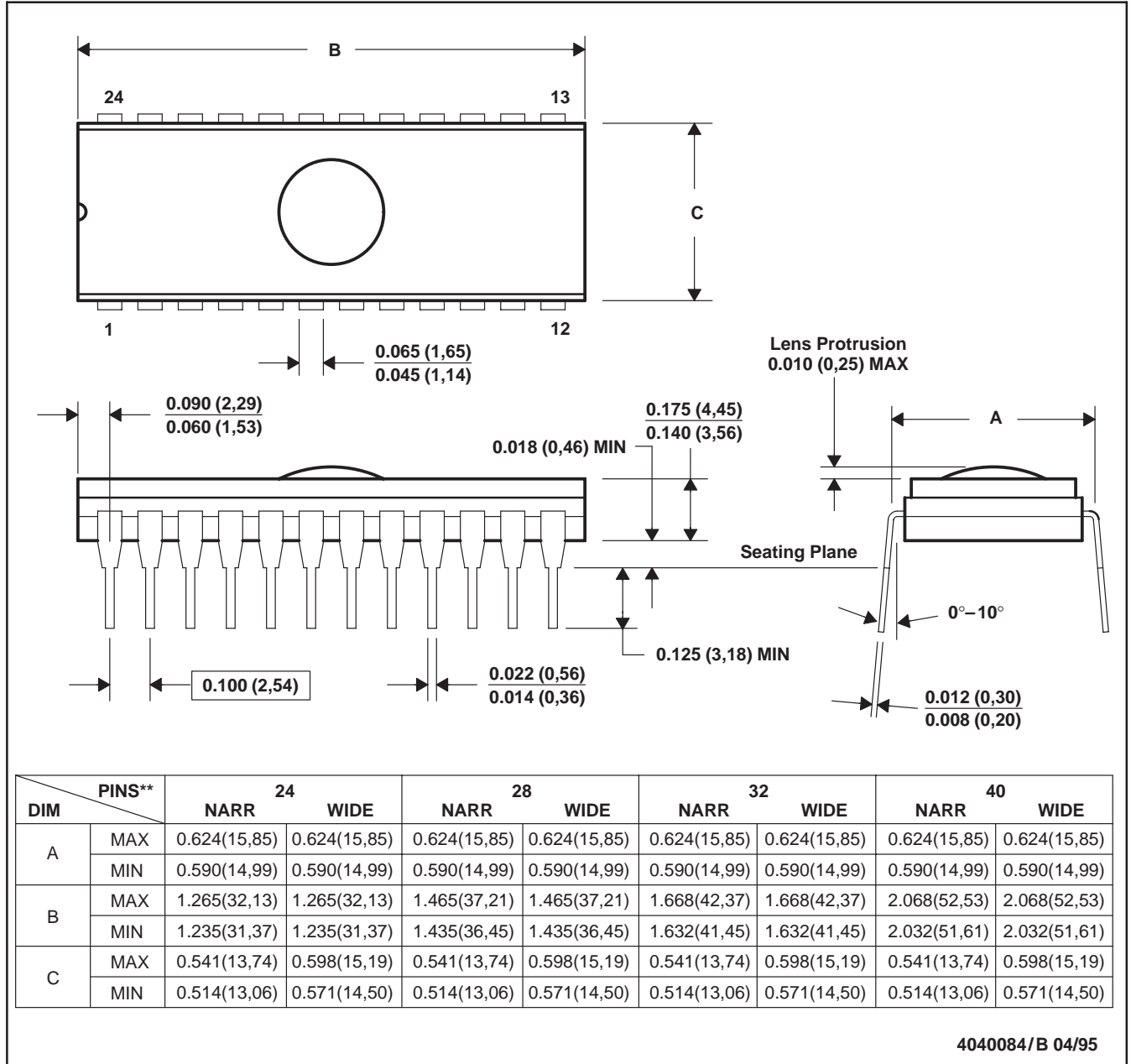

- NOTES: A. All linear dimensions are in inches (millimeters).  
 B. This drawing is subject to change without notice.  
 C. This package can be hermetically sealed with a ceramic lid using glass frit.  
 D. Index point is provided on cap for terminal identification only on press ceramic glass frit seal only.

## **IMPORTANT NOTICE**

Texas Instruments and its subsidiaries (TI) reserve the right to make changes to their products or to discontinue any product or service without notice, and advise customers to obtain the latest version of relevant information to verify, before placing orders, that information being relied on is current and complete. All products are sold subject to the terms and conditions of sale supplied at the time of order acknowledgement, including those pertaining to warranty, patent infringement, and limitation of liability.

TI warrants performance of its semiconductor products to the specifications applicable at the time of sale in accordance with TI's standard warranty. Testing and other quality control techniques are utilized to the extent TI deems necessary to support this warranty. Specific testing of all parameters of each device is not necessarily performed, except those mandated by government requirements.

CERTAIN APPLICATIONS USING SEMICONDUCTOR PRODUCTS MAY INVOLVE POTENTIAL RISKS OF DEATH, PERSONAL INJURY, OR SEVERE PROPERTY OR ENVIRONMENTAL DAMAGE ("CRITICAL APPLICATIONS"). TI SEMICONDUCTOR PRODUCTS ARE NOT DESIGNED, AUTHORIZED, OR WARRANTED TO BE SUITABLE FOR USE IN LIFE-SUPPORT DEVICES OR SYSTEMS OR OTHER CRITICAL APPLICATIONS. INCLUSION OF TI PRODUCTS IN SUCH APPLICATIONS IS UNDERSTOOD TO BE FULLY AT THE CUSTOMER'S RISK.

In order to minimize risks associated with the customer's applications, adequate design and operating safeguards must be provided by the customer to minimize inherent or procedural hazards.

TI assumes no liability for applications assistance or customer product design. TI does not warrant or represent that any license, either express or implied, is granted under any patent right, copyright, mask work right, or other intellectual property right of TI covering or relating to any combination, machine, or process in which such semiconductor products or services might be or are used. TI's publication of information regarding any third party's products or services does not constitute TI's approval, warranty or endorsement thereof.