

March 1997

TP11362A Quad Adaptive Differential PCM Processor

General Description

The TP11362A is a quad (4) channel Adaptive Differential Pulse Code Modulation (ADPCM) transcoder, fully compatible to ITU G.726 recommendation in 40 kbps, 32 kbps, 24 kbps, 16 kbps and ANSI 32 kbps modes. The TP11362A ADPCM processor can operate on up to 8 independent channels in an 8 kHz frame. Each channel is individually configured, supporting both full and half duplex operation. All input/output transfers occur on an interrupt basis using serial, double buffered data registers. Together with National's TP3054/57 COMBO® or TP3070/71 COMBO II devices, the TP11362A forms complete ADPCM channels with Codec/ filtering.

Features

- CCITT G.726 compatible at 40, 32, 24, 16 kbps
- ANSI T1.301 compatible at 32 kbps
- 8-channel half-duplex (encode or decode) or 4-channel full-duplex operation in 8 kHz frame
- Each channel individually configurable
- Selectable μ -law or A-law PCM coding
- Asynchronous 8 MHz master clock operation
- TTL and CMOS compatible inputs and outputs
- 28-pin PLCC or 24-pin DIP packages
- Power consumption of typ. 6 mW at +5V per full-duplex channel
- On-Chip Power-On-Reset
- -40°C to $+85^{\circ}\text{C}$ operating temperature range
- Single 5V supply

Block Diagram

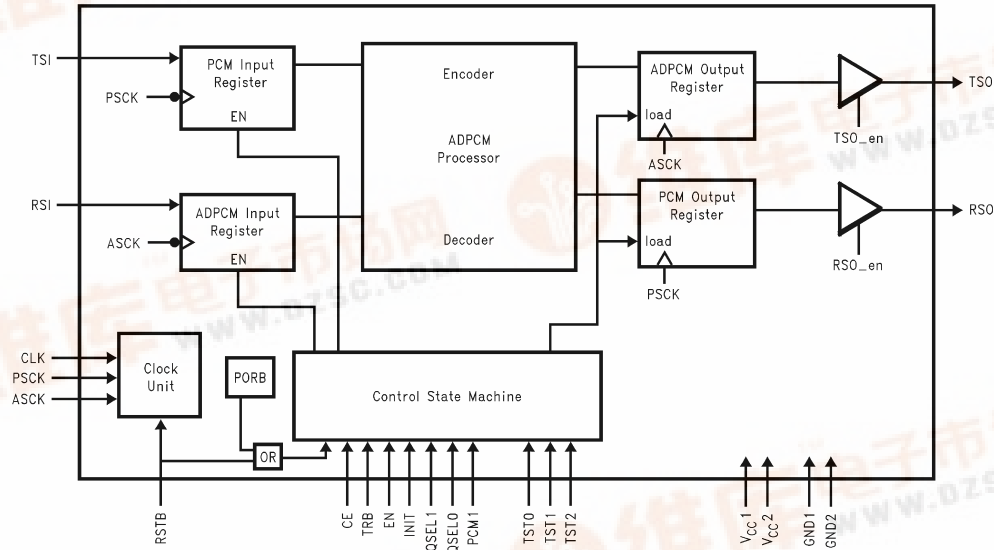

FIGURE 1. Block Diagram

DS012877-1

TRI-STATE® and COMBO® are registered trademarks of National Semiconductor Corporation.



Connection Diagrams

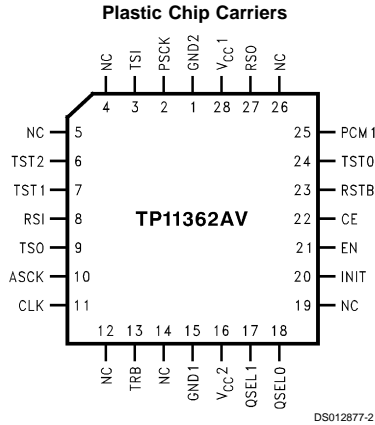

Top View
Order Number TP11362AV
See NS Package Number V28A

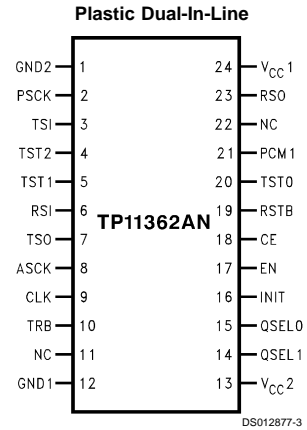

Top View
Order Number TP11362AN
See NS Package Number N24A

Pin Descriptions

TSI

Transmit PCM serial data input. TSI is an 8-bit PCM data stream and is shifted into an 8-bit serial-to-parallel register on the falling edges of PSCK while CE and TRB are high. The last 8 bits of TSI are latched and transferred to the core for processing at the falling edge of CE.

TSO

Transmit ADPCM TRI-STATE® serial data output. A serial data bit stream of 4- to 5-bit length is shifted out with the rising edge of ASCK when CE is high following the processing of a transmit channel. TSO is in TRI-STATE mode while CE is low or while RSO output is active.

RSI

Receive ADPCM serial data input. A serial data bit stream of 4- to 5-bit length is shifted in with the falling edges of ASCK while CE is high and TRB is low. The last 4 or 5 bits of RSI are latched and transferred to the core for processing at the falling edge of CE.

RSO

Receive PCM TRI-STATE serial data output. An 8-bit serial PCM data stream is shifted out with the rising edges of PSCK when CE is high following the processing of a receive channel. RSO is in TRI-STATE mode while CE is low or while TSO output is active.

PSCK

PCM serial clock input. PSCK is used to shift PCM data into TSI or out of RSO while CE is active (high). The transfer depends on the logic state of TRB.

ASCK

ADPCM serial clock input. ASCK is used to shift ADPCM data into RSI or out of TSO while CE is active (high). The transfer depends on the logic state of TRB.

CLK

Master clock input. CLK may be asynchronous to PSCK or ASCK.

CE

Chip enable input. When CE is high, it enables data transfer. The falling edge of CE latches and transfers the serial data TSI or RSI to the core for processing and strobes the control signals QSEL0, QSEL1, PCM1, EN and INIT. CE should change state only when PSCK and ASCK are high. CE, when low, sets the TSO and RSO outputs into TRI-STATE mode.

TRB

Transmitter or receiver select. A logic low at TRB selects the receiver of the channel processed. A logic high enables the transmitter of the channel processed. TRB determines which input register is enabled and which output register and output is enabled. TRB should be stable while CE is high.

EN

Channel enable input. EN is strobed in with the falling edge of CE. A logic high at the falling edge of CE indicates that the channel is active, and the ADPCM will process the data just clocked in.

INIT

Channel initialization input. INIT is read at the falling edge of CE. A logic high at the falling edge of CE causes the ADPCM processor to initialize the channel currently processing.

PCM1

PCM coding law select. A logic low at PCM1 selects 8-bit μ -law, while a logic high selects 8-bit A-law with even bit inversion.

Pin Descriptions (Continued)

QSEL0, QSEL1

ADPCM bit rate select inputs. The QSEL0 and QSEL1 signals are strobed in with the falling edge of CE. The QSEL0 and QSEL1 select the conversion bit rate of the PCM data just clocked in at the TSI input or the bit rate of the ADPCM data just clocked in at the RSI input. See *Table 1*.

RSTB

Chip reset input. A low to high transition at RSTB initiates the reset sequence which initializes the channel variables for all eight channels. A logic low applied to this pin sets the transcoder into a low power dissipation mode. RSTB should be pulled high for normal operation.

TST0, TST1, TST2

Test inputs for factory testing purposes. TST0–2 should be tied low for normal operation.

V_{CC1}, V_{CC2}

Positive power supply input pins. V_{CC} = 5V ±5%. A 0.1 μF ceramic bypass capacitor should be connected between V_{CC1} and GND1, and V_{CC2} and GND2.

GND1, GND2

Ground input pins.

NC

Not connected.

Functional Description

Adaptive Differential Pulse Code Modulation (ADPCM) is a transcoding algorithm for voice and voice band data transmission. The use of ADPCM reduces the channel bandwidth requirements from the standard 64 kbps PCM signal by a factor of two or more. It is used for converting a 64 kbps A-law or μ-law PCM channel to and from a 40, 32, 24 or 16 kbps channel. The 8-bit PCM signal is reduced to 2–5 bits ADPCM signal depending on the selected bit rate in the encoder.

The TP11362A meets the ITU (CCITT) G.726 recommendation for 40, 32, 24, and 16 kbps ADPCM, as well as ANSI T1.301 for 32 kbps. Each channel can be operated with an independently selectable bit rate determined by QSEL1 and QSEL0 (see *Table 1*).

TABLE 1. Bit Rate Selection

QSEL1	QSEL0	ADPCM Bit Rate
0	0	32 kbps
0	1	24 kbps
1	0	16 kbps
1	1	40 kbps

The ADPCM encoder converts the 64 kbps A-law or μ-law PCM input signal to a uniform PCM signal which is subtracted from an estimated signal obtained from an adaptive predictor. A 31-, 15-, 7-, or 4-level non-uniform quantizer is used to assign five, four, three or two binary digits, respectively, to the value of the difference signal for transmission. The ADPCM decoder reconstructs the original PCM signal by adding the received quantized signal to the signal estimation calculated by the predictor. A synchronous coding ad-

justment unit prevents cumulative distortion occurring on synchronous tandem codings (ADPCM-PCM-ADPCM) under certain conditions.

The adaptive predictor consists of two independent predictor structures. One uses a second order recursive filter which models the poles, and the other uses a sixth order non-recursive filter which models the zeros in the input signal. This dual structure enables effective handling of both speech and voice band data signals.

ADPCM PROCESSING

ADPCM to PCM Decoding Operation

When a logic “0” of TRB is latched in with the falling edge of CE, the ADPCM processor is set to the decoding mode. Data applied at the RSI input is sampled with the falling edge of ASCK into a 5-bit ADPCM serial register. Within the next cycle of CE, the decoder converts the ADPCM input data to an 8-bit companded PCM data after 123 master clocks (CLK). The 8-bit parallel PCM data is loaded into a parallel-to-serial shift register and shifted out at the RSO output with the rising edges of PSCK.

PCM to ADPCM Encoding Operation

A logic “1” of TRB at the falling edge of CE sets the ADPCM processor to the encoding mode. Data applied at the TSI input is sampled in an internal 8-bit PCM register with the falling edge of PSCK. During the next cycle of CE, the encoder converts the companded 8-bit PCM data into a 5-, 4-, 3- or 2-bit ADPCM data, which will be shifted out during the third cycle of CE at the TSO output with the rising edges of ASCK.

The TP11362A requires one master clock signal CLK. The master clock signal CLK is not required to be synchronous to the serial I/O clocks ASCK or PSCK. The serial interface uses the serial clocks ASCK and PSCK and chip enable CE for receiving and transmitting data. The data is internally synchronized to the master clock CLK. There is a lower limit of the clock frequency for CLK resulting from the number of clock cycles required for processing the data. *Table 2* shows the required clock cycles per channel depending on the selected mode.

TABLE 2. Processing Cycles

Mode of Operation	CLK Cycles Needed
Decoder	123
Encoder	123
Initialized Channel	45
Disabled Channel	4

The sampling period (usually 125 μs for 8 kHz frame) divided by the number of CLK cycles gives the required minimum CLK period. A slightly higher CLK frequency is used in order to allow for jitter and inaccuracies in the CLK rate. As an example, for a four channel ADPCM codec, CLK frequency is 8 MHz as shown in the following calculations:

$$t_{CLK} = 125 \mu s / (8 * 123) = 127.03 \text{ ns}$$

$$f_{CLKmin} = 1/t_{CLK} = 7.872 \text{ MHz}$$

$$f_{CLKnom} = 8.0 \text{ MHz}$$

The period of CE must be equal to or greater than the required number of CLK cycles times the period of CLK. CE must be low for more than 4 CLK cycles.

Functional Description (Continued)

The TP11362A is capable of processing eight independent channels (half duplex) or four full-duplex PCM channels within 125 μ s (8 kHz).

The logic state of TRB at the falling edge of CE determines which input register is active during that CE period and which output register will be active in the following third CE period.

The input data is processed (PCM data encoded or ADPCM data decoded) during the second cycle and shifted out in the third cycle of CE while CE is high.

SERIAL I/O

Input data is transferred into the TP11362A on the falling edge of the clock signal, while output data is transmitted on the rising edge of the clock signal. PCM data is transferred synchronously using PSCK, while ADPCM data is transferred synchronously using ASCK. The clock signals ASCK and PSCK should be high while CE changes. All serial data is transferred with MSB first. *Figure 2* and *Figure 3* show the serial input and output structures, respectively.

PCM Serial Input Register

The serial PCM data to be encoded is shifted into the 8-bit PCM input register with the falling edges of PSCK while CE and TRB are high. The falling edge of CE latches the state of

the input register and transfers the last 8 bits data prior to the CE transition to the core for processing. The 8-bit PCM input register is cleared asynchronously with RSTB going low.

ADPCM Serial Input Register

The ADPCM serial input register is a 5-bit shift register to store the 5-bit data in the 40 kbps ADPCM mode. Serial input data is latched in with the falling edges of ASCK while CE is high and TRB is low. A minimum number of five low going ASCK pulses must be available within the CE pulse when operating in the 40 kbps mode. For the 32, 24 and 16 kbps modes, ASCK must be pulsed low 4 times while CE is high to read in the RSI data. The falling edge of CE latches the last 5 bits data in the 40 kbps mode or the last 4 bits data in the 32, 24, and 16 kbps modes prior to the CE transition. See *Table 3* for the position of the ADPCM data in the 5-bit input register when 5 ASCK low going pulses occur while CE is high and TRB is low. Bit 1 in *Table 3* is the LSB which is the last bit in 32 and 40 kbps modes referenced to the negative edge of CE.

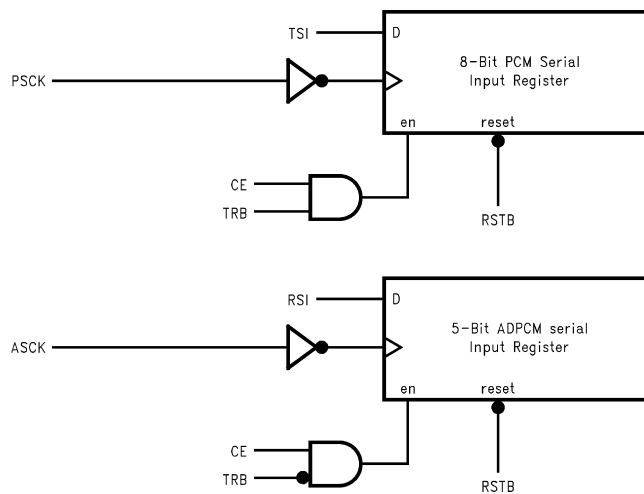

FIGURE 2. Serial Input Structure

DS012877-4

ADPCM Output Register

The internal encoded parallel ADPCM data is loaded into the 5-bit ADPCM output register with the falling edge of CE signal. The first MSB data is shifted out after the rising edge of CE, subsequent ADPCM serial data is shifted out with the rising edge of ASCK. *Table 4* shows the transfer order of the ADPCM output data. If more than 4 ASCK clocks are available while CE is high in the 32, 24, and 16 kbps modes, the ADPCM output data will recirculate starting with the MSB. In the case of the 40 kbps mode, the ADPCM output pattern will recirculate, starting with the MSB, with the fifth rising edge of ASCK while CE is high.

PCM Output Register

The decoded 8-bit parallel PCM data is loaded into an 8-bit parallel-to-serial output shift register with the falling edge of CE. The MSB data is shifted out with the leading edge of CE, and subsequent data are shifted out with the rising edges of PSCK while CE is high. The 8-bit PCM data at the RSO output will recirculate with the MSB first after the seventh rising edge of PSCK while CE is high.

Figure 4 shows the full duplex timing diagram for the 40 kbps mode. For the 32, 24 and 16 kbps modes only four ASCK low pulses are needed while CE is high.

TRB is alternate high and low in the full duplex mode at each falling edge of CE for a transmit (encoder) operation followed

Functional Description (Continued)

by a receive (decoder) operation. For the encoding operation, the PCM data is stored in the 8-bit shift register at the falling edge of CE while TRB is high. The TP11362A processes the data within 123 CLK periods during the following cycle of CE. The encoded ADPCM data is loaded into the 5-bit parallel-to-serial output register with the falling edge of CE. The MSB data is shifted out first with the leading edge of CE, and subsequent data is shifted out with the rising edge of ASCK. For the decoding operation, the ADPCM data is

latched and transferred to the core at the falling edge of CE while TRB is low. The data is processed within 123 CLK periods and the decoded 8-bit PCM data is shifted out with the MSB first.

PSCK and ASCK are the clocks for the PCM and ADPCM data streams, respectively. They must be high during the transition of CE. Note that PSCK and ASCK are shown as gated clocks as an option to conserve power. PSCK and ASCK need only be valid while CE is high.

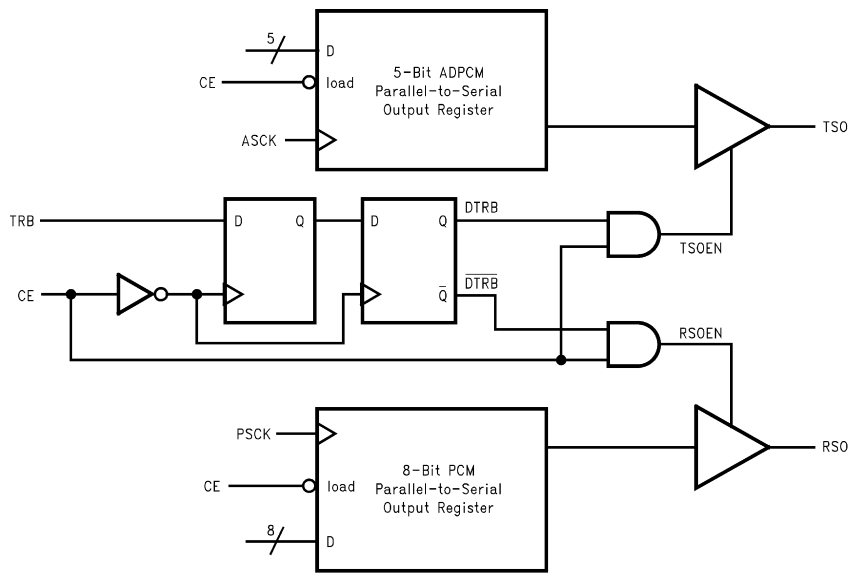

DS012877-5

FIGURE 3. Serial Output Structure

Functional Description (Continued)

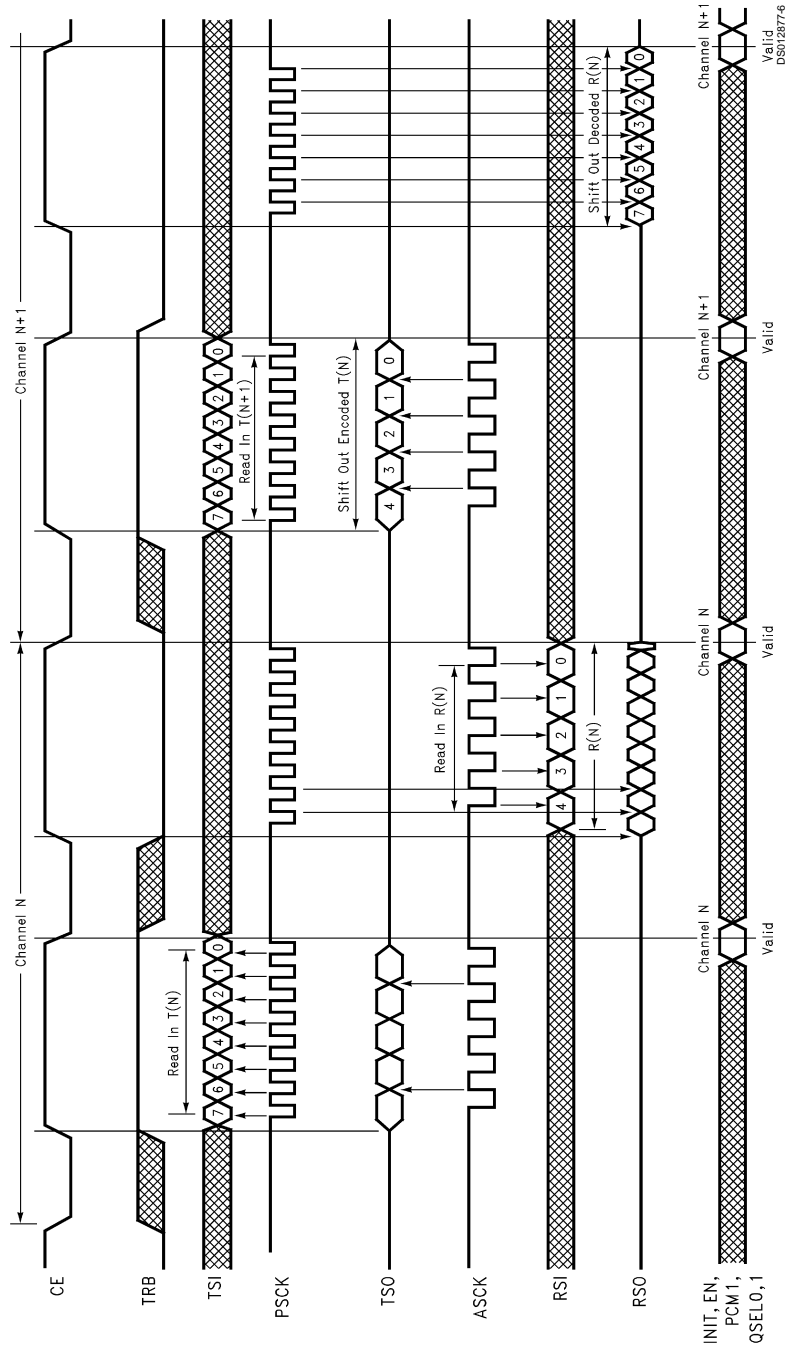

FIGURE 4. Full Duplex Timing Diagram (40 kbps ADPCM mode)

Valid
DS912877e

Functional Description (Continued)

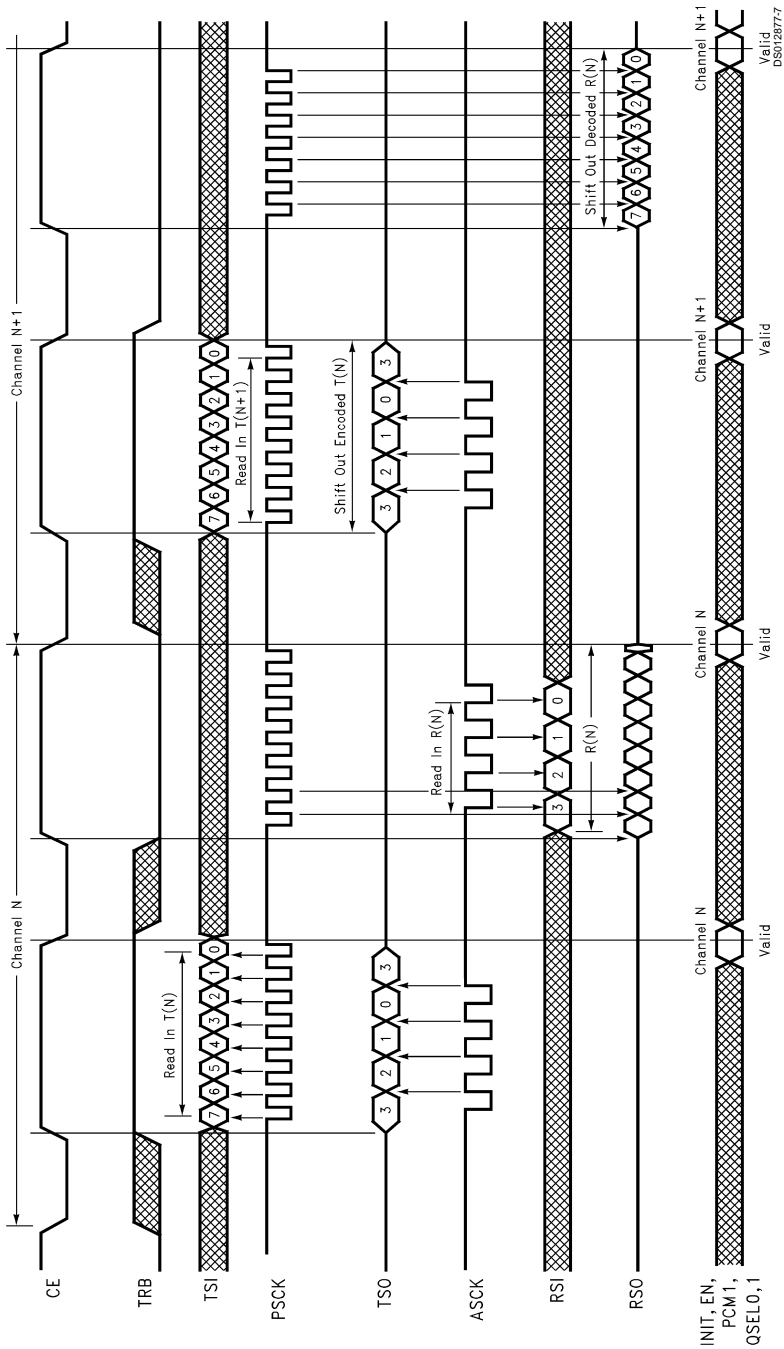

FIGURE 5. Full Duplex Timing Diagram (32 kbps ADPCM mode)

Table 3 shows the position of the ADPCM data in the 5-bit input register when five ASCK low going pulses are available while CE is high. Only the last four bits of the ADPCM input register prior to the falling edge of CE are latched in and

transferred to the core for processing in the 32, 24 and 16 kbps modes. In the 40 kbps mode, the last five bits prior

Functional Description (Continued)

to the falling edge of CE are latched in. In *Table 3*, the last input bit prior to the CE falling edge is the LSB of the ADPCM data word.

Note that the serial input data is referenced to the falling edge of CE while the serial output data is referenced to the rising edge of CE. TSI and RSI input data are clocked in with the false edge of PSCK and ASCK, respectively. The MSB of TSO and RSO output data are shifted out with the falling

edge of CE. Subsequent TSO and RSO data are shifted out with the rising edges of ASCK and PSCK respectively.

Table 4 shows the transfer order of the ADPCM output data. In the case where there are more ASCK clocks than the ADPCM data, the ADPCM output will recirculate.

For example, if the 32 kbps mode is selected, and eight low pulses of ASCK exist within the CE high pulse, the following ADPCM encoded data D3-D2-D1-D0-D3-D2-D1-D0 will appear at the TSO output (*Table 5*).

TABLE 3. Transfer Order of ADPCM Input Data (RSI). The Last Bit Prior to the Falling Edge of CE is the LSB of the ADPCM Data

QSEL1	QSEL0	Mode	Bit 5	Bit 4	Bit 3	Bit 2	Bit 1
0	0	32 kbps	x	D3	D2	D1	D0
0	1	24 kbps	x	D2	D1	D0	x
1	0	16 kbps	x	D1	D0	x	x
1	1	40 kbps	D4 (MSB)	D3	D2	D1	D0 (LSB)

Note 1: x = Don't Care state

TABLE 4. Transfer Order of ADPCM Output Data (TSO) with 4 ASCK Rising Edges while CE is High (the First Bit is the MSB Data Bit following the Rising Edge of CE)

QSEL1	QSEL0	Mode	Bit 5	Bit 4	Bit 3	Bit 2	Bit 1
0	0	32 kbps	D3	D2	D1	D0	D3
0	1	24 kbps	D2	D1	D0	x	D2
1	0	16 kbps	D1	D0	x	x	D1
1	1	40 kbps	D4 (MSB)	D3	D2	D1	D0 (LSB)

Note 2: x = unknown (but defined) state

TABLE 5. Transfer Order of ADPCM Output Data (TSO) with 7 ASCK Rising Edges (8 Low Pulses) of ASCK while CE is High

QSEL1	QSEL0	Mode	Bit 8	Bit 7	Bit 6	Bit 5	Bit 4	Bit 3	Bit 2	Bit 1
0	0	32 kbps	D3	D2	D1	D0	D3	D2	D1	D0
0	1	24 kbps	D2	D1	D0	x	D2	D1	D0	x
1	0	16 kbps	D1	D0	x	x	D1	D0	x	x
1	1	40 kbps	D4	D3	D2	D1	D0	D4	D3	D2

Note 3: x = unknown (but defined) state

SINGLE-CHANNEL INITIALIZATION AND ALL-CHANNEL RESET

The TP11362A ADPCM processor can be initialized on a per-channel basis via the use of INIT or on an all-channel basis via the use of RSTB. In both cases, the internal ADPCM variables are initialized to the default values as suggested by the ITU G.726 recommendation.

An individual channel can be initialized to the desired configuration by setting the corresponding data variables PCM1, EN, QSEL(0,1) and by asserting the INIT pin high. The configuration data and INIT signal are strobed at the falling edge of CE. For an initialization cycle, the period of CE must be 45 master clock (CLK) cycles. The transcoder is then ready to process the next channel.

The active low RSTB signal is used for a "warm" reset as well as for facilitating device testing. The initialization of the

internal memory takes 726 CLK cycles after the RSTB goes inactive (logic "1"). The first transition of CE is allowed six CLK cycles after RSTB goes inactive. It is recommended that CE be kept low during the initialization phase. The recommended values for ASCK and PSCK during initialization are logic "1", and that for TSI and RSI logic "0". Any data (TSI and RSI) applied during the initialization phase will be lost, however, they won't affect the proper initialization process. The minimum low time of RSTB is 2 CLK cycles.

The chip resumes operation on the first negative edge of CE after the completion of the initialization.

POWER-ON-RESET

The on-chip Power-On-Reset macro is activated when external power is first applied to the device. It has the same function as the external RSTB pin which initializes all channels to the default values defined in the ITU Recommendation

Functional Description (Continued)

G.726. At power up, the outputs TSO and RSO are in TRI-STATE mode. This “cold” reset process is asynchronous and takes approximately 2000 CLK cycles for the initialization. During the reset process, the outputs TSO and RSO are in TRI-STATE mode.

CHANNEL NOP

Each channel can be independently disabled. When EN is at logic low on the falling edge of CE, the ADPCM transcoder processing for that channel is disabled. The processor requires 4 CLK cycles for CE to maintain all channel variables. The data output ports are also placed in known states. After this the processor waits for the next interrupt. Power is conserved during this time by disabling the internal registers. TSO outputs the following data after a channel NOP:

TABLE 6. TSO at Channel NOP

QSEL1	QSEL0	Mode	TSO
0	0	32 kbps	0 0 0 0
0	1	24 kbps	0 0 0 0
1	0	16 kbps	0 0 0 0
1	1	40 kbps	0 0 0 0 0

The data pattern at TSO in *Table 6* are shown with 3 ASCK rising edges within the CE high pulse for the 32, 24, 16 kbps modes and 4 ASCK rising edges within the CE high pulse for the 40 kbps mode (the MSB is shifted out with the falling edge of CE). In the idle case (NOP) where EN is low at the falling edge of CE, the TSO output is low for the duration of the high CE pulse.

In the idle state (NOP), RSO outputs the following data (bit representation with the sign-bit on the left followed by the MSB, the sign-bit is the first bit after the rising edge of CE):

TABLE 7. RSO at Channel NOP

PCM1	Mode	RSO
0	8-Bit μ -Law	1 1 1 1 1 1 1 1
1	8-Bit A-Law	1 1 0 1 0 1 0 1

Absolute Maximum Ratings (Note *NO TGT: FNXref NS0465*)	Storage Temperature Range	-45°C to +125°C	
If Military/Aerospace specified devices are required, please contact the National Semiconductor Sales Office/ Distributors for availability and specifications.	Lead Temperature		
	(Soldering, 10 sec)	300°C	
	Latch-up Immunity on any Pin	±75 mA	
	θ_{JA} (28-pin PLCC)	79°C/W	
V_{CC} to GND	7V	θ_{JA} (24-pin DIP)	49°C/W
Voltage at Any Digital Inputs or Outputs	GND - 0.3V to V_{CC} + 0.3V		

DC Electrical Characteristics

Unless otherwise noted, limits printed in **bold** characters are guaranteed for $V_{CC} = 5.0V \pm 5\%$, $GND1 = GND2 = 0V$, $T_A = -40^\circ C$ to $+85^\circ C$ by correlation with 100% electrical testing at $T_A = 25^\circ C$. All other limits are assured by correlation with other production tests and/or product design and characterization. Typical values are specified at $V_{CC} = +5V$, $T_A = 25^\circ C$.

Symbol	Parameter	Conditions	Min	Typ	Max	Units
I_{CC0}	Supply Current (Power Down Mode)	CLK = 8.0 MHz, RSTB = Low			1.8	mA
I_{CC1}	Supply Current (Power Up Mode)	CLK = 8.0 MHz, RSTB = High		7	9	mA
P_D	Power Dissipation			35		mW
V_{IL}	Input Low Voltage	ASCK, PSCK, CE, TRB,			0.8	V
V_{IH}	Input High Voltage	CLK, RSTB	2.4			V
V_{IL}	Input Low Voltage	PCM1, RSI, TSI, QSEL0,			0.7	V
V_{IH}	Input High Voltage	QSEL1, INIT, EN	2.0			V
V_{OL}	Output Low Voltage	$I_L = 4$ mA			0.4	V
V_{OH}	Output High Voltage	$I_L = -4$ mA	2.4			V
		$I_L = -0.4$ mA; $V_{CC} = 4.75V$	$V_{CC} - 0.8$			V
I_{IL}	Input Low Current	$GND < V_{IN} < V_{IL}$, All Signal Inputs	-10			μA
I_{IH}	Input High Current	$V_{IH} < V_{IN} < V_{CC}$, All Signal Inputs			10	μA
		Test Inputs TST0, TST1, TST2 (Note 4)			150	μA
I_{OZ}	Output Current in High Impedance State	$GND < V_O < V_{CC}$, TSO and RS0	-10		10	μA
C_1	Input Capacitance				10	pF
C_O	Output Capacitance				10	pF
C_L	Capacitive Load				100	pF

Note 4: Test inputs have internal pull-down resistor.

Timing Specifications

Unless otherwise noted, limits printed in **bold** characters are guaranteed for $V_{CC} = 5.0V \pm 5\%$, $GND1 = GND2 = 0V$, $T_A = -40^\circ C$ to $+85^\circ C$ by correlation with 100% electrical testing at $T_A = 25^\circ C$. All other limits are assured by correlation with other production tests and/or product design and characterization. Typical values are specified at $V_{CC} = +5V$, $T_A = 25^\circ C$.

Symbol	Parameter	Conditions	Min	Typ	Max	Units
f_{CLK}	CLK Frequency (Note 5)	Assuming 50% Duty Cycle	7.9	8.0	16	MHz
t_{CLK}	CLK Duty-Cycle		40%	50%	60%	CLK Period
t_R	Rise Time (CLK, CE, ASCK, PSCK)				10	ns
t_F	Fall Time (CLK, CE, ASCK, PSCK)				10	ns
t_{CEP}	CE Period	Encode or Decode	123			CLK Cycles
		Initialization	45			
		Disable	9			
t_{CEL}	CE Pulse Width, Low		4			CLK Cycles

Timing Specifications (Continued)

Unless otherwise noted, limits printed in **bold** characters are guaranteed for $V_{CC} = 5.0V \pm 5\%$, $GND1 = GND2 = 0V$, $T_A = -40^\circ C$ to $+85^\circ C$ by correlation with 100% electrical testing at $T_A = 25^\circ C$. All other limits are assured by correlation with other production tests and/or product design and characterization. Typical values are specified at $V_{CC} = +5V$, $T_A = 25^\circ C$.

Symbol	Parameter	Conditions	Min	Typ	Max	Units
t_{HDCEL}	Hold Time, CE low after PSCK/ASCK High	From CE Low	15			ns
t_{SUCEH}	Setup Time, CE High Before PSCK/ASCK Low	From CE Low	15			ns
t_{TRBH}	TRB Hold Time	From CE Low	20			ns
t_{TRBS}	TRB Setup Time	From ASCK Low and PSCK Low	20			ns
t_{IS}	TSI, RSI Setup Time	From ASCK Low and PSCK Low	20			ns
t_{IH}	TSI, RSI Hold Time	From ASCK Low and PSCK Low	20			ns
$t_{PSCK/ASCK}$	PSCK/ASCK High and Low Times		55			ns
t_{ON}	TSO, RSO Turn On Time	From CE High			40	ns
t_{OD}	TSO, RSO Propagation Delay Time	From ASCK High or PSCK High			40	ns
t_{OFF}	TSO, RSO Turn Off Time (Valid Data to TRI-STATE)	From CE Low			20	ns
t_{CS}	Setup Time for Control Signals (INIT, EN, PCM1, QSEL1, QSEL0)	From CE Low	20			ns
t_{CH}	Hold Time for Control Signals (INIT, EN, PCM1, QSEL1, QSEL0)	From CE Low	20			ns
t_{RSTL}	RSTB Pulse Width Low		2			CLK Cycles
t_{RSTH}	RSTB High to the First CE High-Low Transition		6			CLK Cycles

Note 5: Values for 4 full-duplex (decoding and encoding) or 8 half-duplex (decoding or encoding) channels operation in a 125 μs period.

Timing Specifications (Continued)

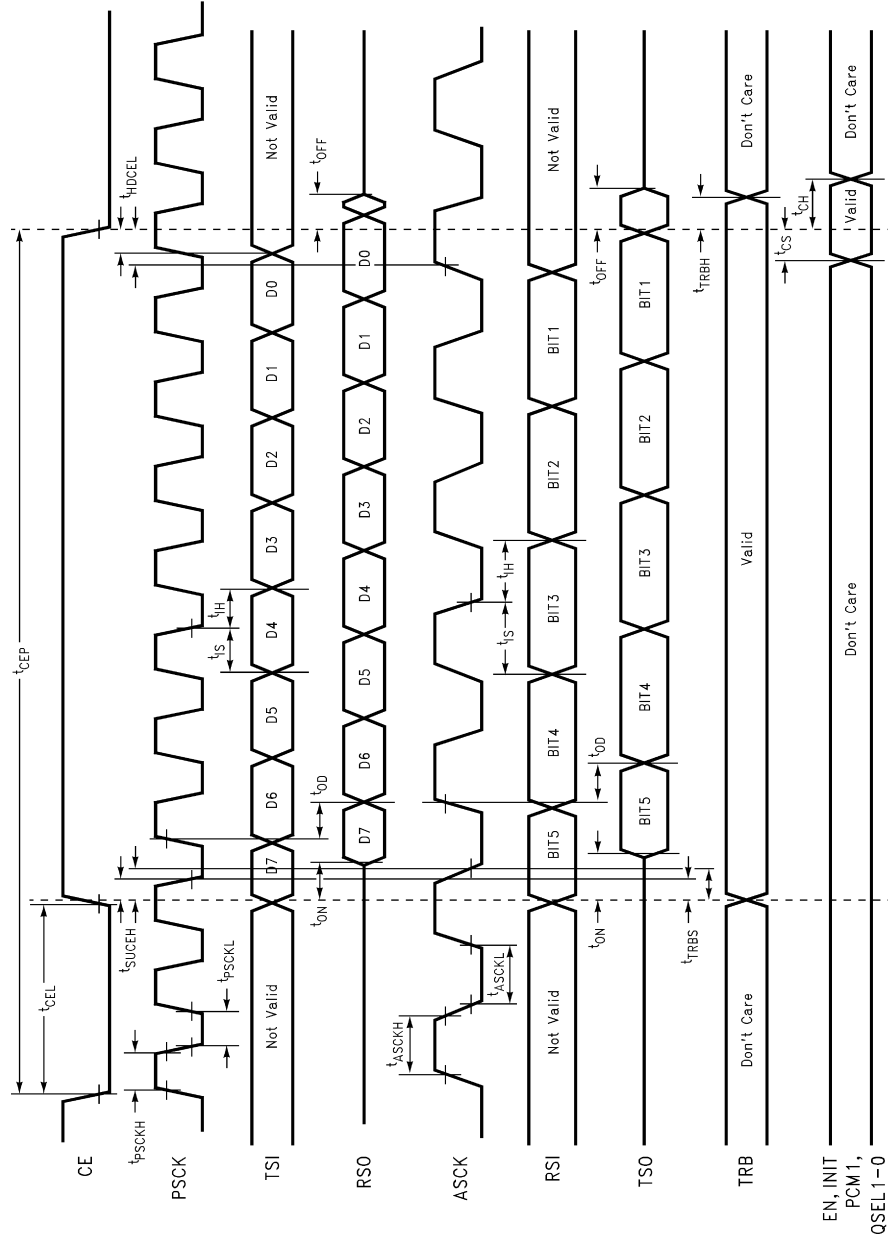

DS012877-9

FIGURE 6. ADPCM Timing

Applications Information

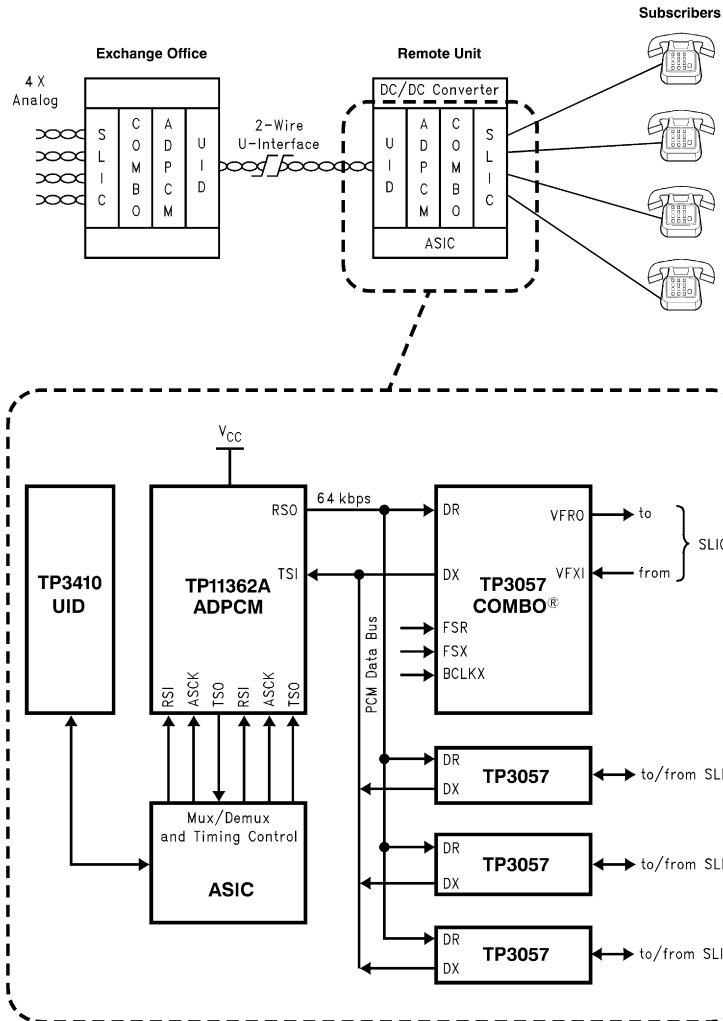
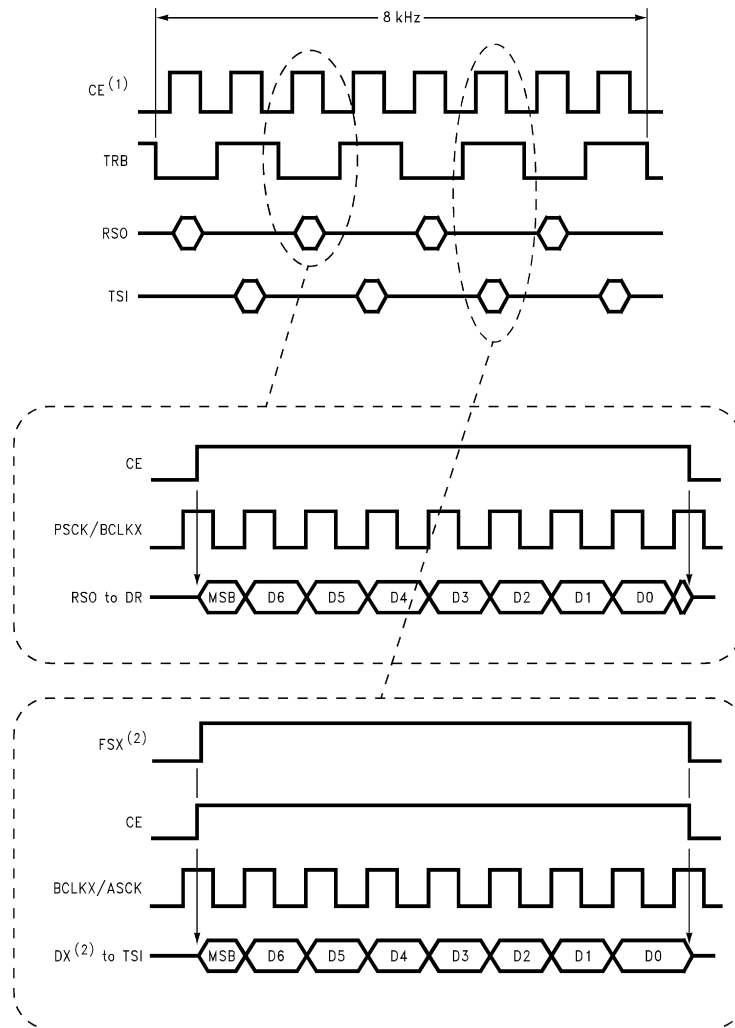

FIGURE 7. Typical Application in an ISDN Pair Gain System

DS012877-9

Applications Information (Continued)



DS012877-10

Note 6: The duty cycle of CE can be adjusted to adapt to different PCM data bit clocks of the COMBO.

Note 7: The DX data output is shown with the long frame sync mode (non-delayed data timing mode).

FIGURE 8. Example of a Timing Interface between an ADPCM and a COMBO

Physical Dimensions inches (millimeters) unless otherwise noted

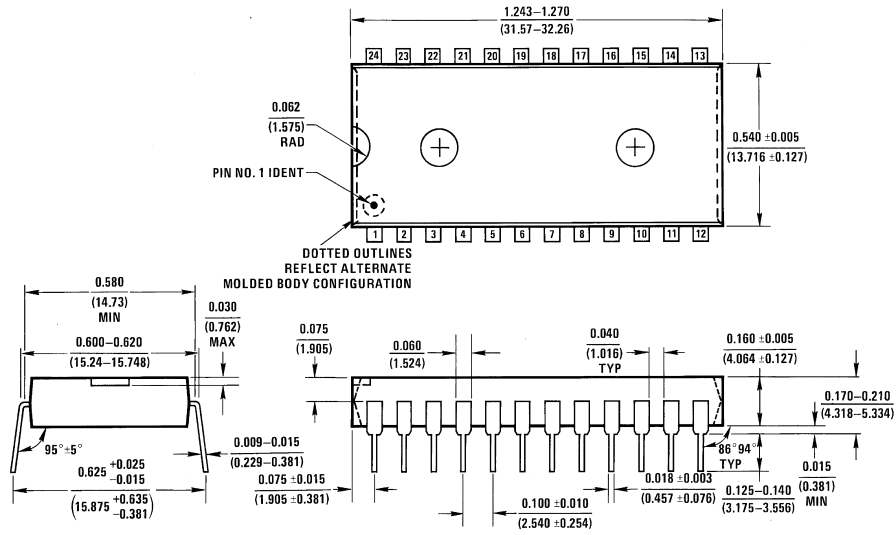

N24A (REV E)

24-Lead (0.600" Wide) Molded Dual-In-Line Package
Order Number TP11362AN
NS Package Number N24A

Physical Dimensions inches (millimeters) unless otherwise noted (Continued)

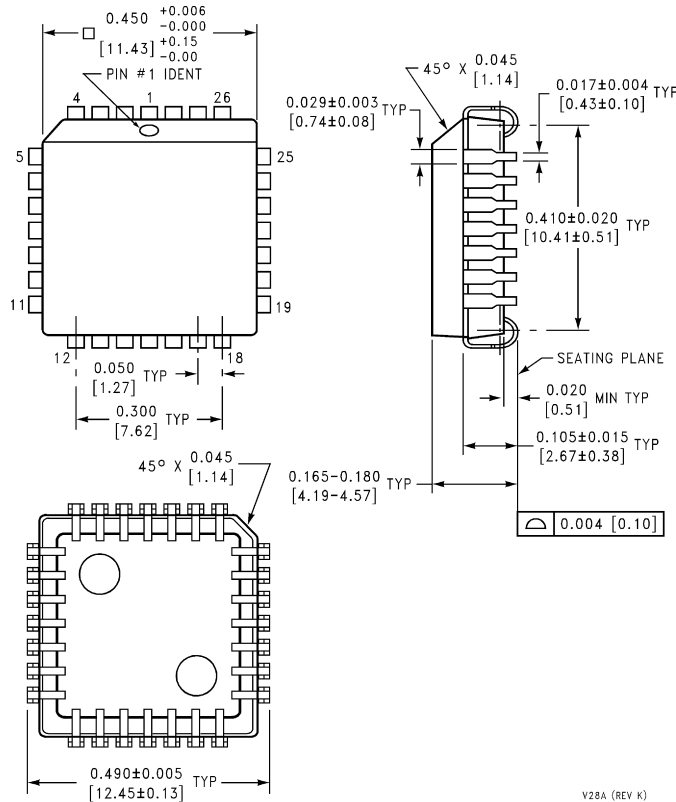

28-Lead Molded Plastic Leaded Chip Carrier
Order Number TP11362AV
NS Package Number V28A

LIFE SUPPORT POLICY

NATIONAL'S PRODUCTS ARE NOT AUTHORIZED FOR USE AS CRITICAL COMPONENTS IN LIFE SUPPORT DEVICES OR SYSTEMS WITHOUT THE EXPRESS WRITTEN APPROVAL OF THE PRESIDENT OF NATIONAL SEMICONDUCTOR CORPORATION. As used herein:

1. Life support devices or systems are devices or systems which, (a) are intended for surgical implant into the body, or (b) support or sustain life, and whose failure to perform when properly used in accordance with instructions for use provided in the labeling, can be reasonably expected to result in a significant injury to the user.
2. A critical component in any component of a life support device or system whose failure to perform can be reasonably expected to cause the failure of the life support device or system, or to affect its safety or effectiveness.



National Semiconductor Corporation
 Americas
 Tel: 1-800-272-9959
 Fax: 1-800-737-7018
 Email: support@nsc.com

www.national.com

National Semiconductor Europe
 Fax: +49 (0) 1 80-530 85 86
 Email: europe.support@nsc.com
 Deutsch Tel: +49 (0) 1 80-530 85 85
 English Tel: +49 (0) 1 80-532 78 32
 Français Tel: +49 (0) 1 80-532 93 58
 Italiano Tel: +49 (0) 1 80-534 16 80

National Semiconductor Hong Kong Ltd.
 13th Floor, Straight Block,
 Ocean Centre, 5 Canton Rd.
 Tsimshatsui, Kowloon
 Hong Kong
 Tel: (852) 2737-1600
 Fax: (852) 2736-9960

National Semiconductor Japan Ltd.
 Tel: 81-3-5620-6175
 Fax: 81-3-5620-6179