



October 1991

TP5088 DTMF Generator for Binary Data

General Description

This CMOS device provides low cost tone-dialing capability in microprocessor-controlled telephone applications. 4-bit binary data is decoded directly, without the need for conversion to simulated keyboard inputs required by standard DTMF generators. With the TONE ENABLE input low, the oscillator is inhibited and the device is in a low power idle mode. On the low-to-high transition of TONE ENABLE, data is latched into the device and the selected tone pair from the standard DTMF frequencies is generated. An open-drain N-channel transistor provides a MUTE output during tone generation.

Features

- Direct microprocessor interface
- Binary data inputs with latches
- Generates 16 standard tone pairs
- On-chip 3.579545 MHz crystal-controlled oscillator
- Better than 0.64% frequency accuracy
- High group pre-emphasis
- Low harmonic distortion
- MUTE output interfaces to speech network
- Low power idle mode
- 3.5V–8V operation

Block Diagram

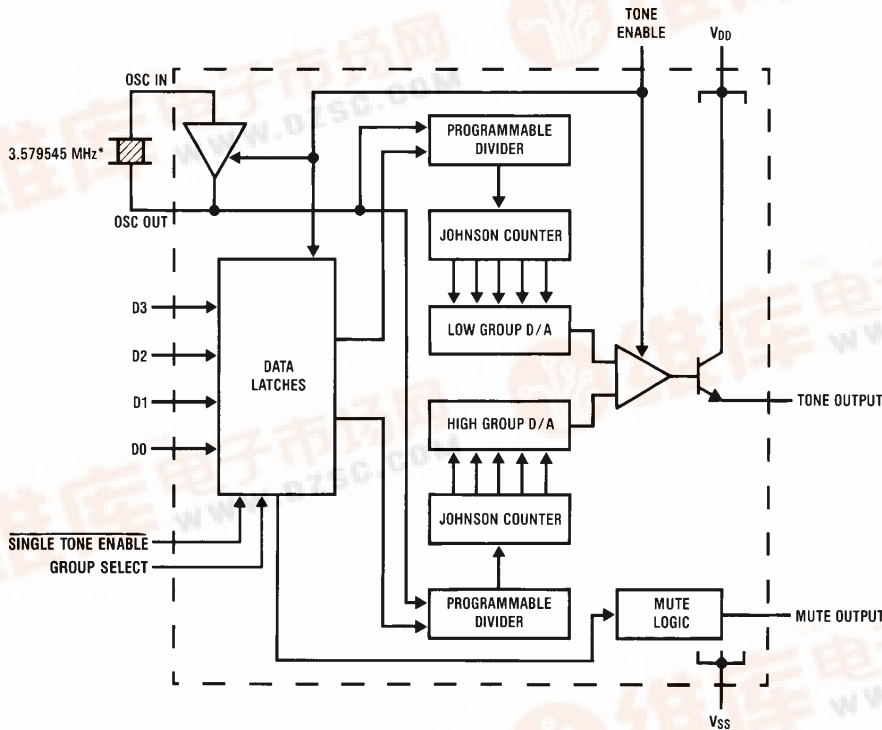

*Crystal Specification: Parallel Resonant 3.579545 MHz, $R_S \leq 150\Omega$, $L = 100\text{ mH}$, $C_0 = 5\text{ pF}$, $C_1 = 0.02\text{ pF}$.

TL/H/5004-1



Absolute Maximum Ratings

If Military/Aerospace specified devices are required, please contact the National Semiconductor Sales Office/Distributors for availability and specifications.

Supply Voltage ($V_{DD} - V_{SS}$)	12V
MUTE Voltage	12V
Maximum Voltage at Any Other Pin	$V_{DD} + 0.3V$ to $V_{SS} - 0.3V$

Operating Temperature, T_A	-30°C to +70°C
Storage Temperature	-55°C to +150°C
Maximum Power Dissipation	500 mW

Electrical Characteristics

Unless otherwise noted, limits printed in **BOLD** characters are guaranteed for $V_{DD} = 3.5V$ to $8V$, $T_A = 0^\circ C$ to $+70^\circ C$ by correlation with 100% electrical testing at $T_A = 25^\circ C$. All other limits are assured by correlation with other production tests and/or product design and characterization.

Parameter	Conditions	Min	Typ	Max	Units
Minimum Supply Voltage, V_{DD} (min)	Generating Tones	3.5			V
Minimum Supply Voltage for Data Input, TONE ENABLE and MUTE Logic Functions		2			V
Operating Current Idle	$R_L = \infty$, D0-D3 Open		55	350	μA
Generating Tones	$V_{DD} = 3.5V$, Mute Open		1.5	2.5	mA
Input Pull-Up Resistance D0-D3			100		k Ω
TONE ENABLE			50		k Ω
Input Low Level TONE ENABLE, D0-D3				0.2 V_{DD}	V
Input High Level TONE ENABLE, D0-D3		0.8 V_{DD}			V
MUTE OUT Sink Current (TONE ENABLE LOW)	$V_{DD} = 3.5V$ $V_o = 0.5V$	0.4			mA
MUTE OUT Leakage Current (TONE ENABLE HIGH)	$V_{DD} = 3.5V$ $V_o = V_{DD}$		1		μA
Output Amplitudes Low Group	$R_L = 240 \Omega$ $V_{DD} = 3.5V$	130	170	220	mVrms
High Group	$T_A = 25^\circ C$	180	230	310	mVrms
Mean Output DC Offset	$V_{DD} = 3.5V$ $V_{DD} = 8V$		1.2 3.6		V V
High Group Pre-Emphasis		2.2	2.7	3.2	dB
Dual Tone/Total Harmonic Distortion Ratio	1 MHz Bandwidth, $V_{DD} = 5V$ $R_L = 240\Omega$	-20			dB
Start-Up Time (to 90% Amplitude), t_{OSC}			4		ms
Data Set-Up Time, t_S (Figure 2)	$V_{DD} = 5V$	100			ns
Data Hold Time, t_H	$V_{DD} = 5V$	280			ns
Data Duration t_W	$V_{DD} = 5V$	600			ns

Note 1: R_L is the external load resistor connected from TONE OUT to V_{SS} .

Connection Diagram

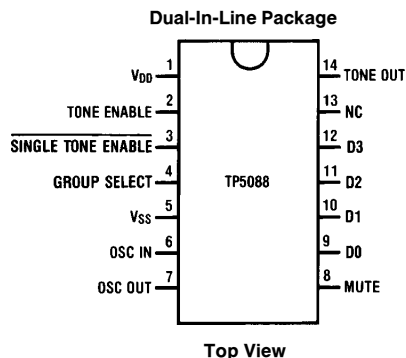

TL/H/5004-2

Order Number TP5088WM or TP5088N
See NS Package M14B or N14A

Functional Description

With the TONE ENABLE pin pulled low, the device is in a low power idle mode, with the oscillator inhibited and the output transistor turned off. Data on inputs D0–D3 is ignored until a rising transition on TONE ENABLE. Data meeting the timing specifications is latched in, the oscillator and output stage are enabled, and tone generation begins. The decoded data sets the high group and low group programmable counters to the appropriate divide ratios. These counters sequence two ratioed-capacitor D/A converters through a series of 28 equal duration steps per sine wave cycle. On-chip regulators ensure good stability of tone amplitudes with variations in supply voltage and temperature. The two tones are summed by a mixer amplifier, with pre-emphasis applied to the high group tone. The output is an NPN emitter-follower requiring the addition of an external load resistor to V_{SS} .

Table I shows the accuracies of the tone output frequencies and Table II is the Functional Truth Table.

TABLE I. Output Frequency Accuracy

Tone Group	Standard DTMF (Hz)	Tone Output Frequency	% Deviation from Standard	
Low Group	697	694.8	-0.32	
	770	770.1	+0.02	
	f_L	852	852.4	+0.03
	941	940.0	-0.11	
High Group	1209	1206.0	-0.24	
	1336	1331.7	-0.32	
	f_H	1477	1486.5	+0.64
	1633	1639.0	+0.37	

Pin Descriptions

V_{DD} (Pin 1): This is the positive supply to the device, referenced to V_{SS} . The collector of the TONE OUT transistor is also connected to this pin.

V_{SS} (Pin 5): This is the negative voltage supply. All voltages are referenced to this pin.

OSC IN, OSC OUT (Pins 6 and 7): All tone generation timing is derived from the on-chip oscillator circuit. A low-cost

3.579545 MHz A-cut crystal (NTSC TV color-burst) is needed between pins 6 and 7. Load capacitors and a feedback resistor are included on-chip for good start-up and stability. The oscillator is stopped when the TONE ENABLE input is pulled to logic low.

TONE ENABLE Input (Pin 2): This input has an internal pull-up resistor. When TONE ENABLE is pulled to logic low, the oscillator is inhibited and the tone generators and output transistor are turned off. A low to high transition on TONE ENABLE latches in data from D0–D3. The oscillator starts, and tone generation continues until TONE ENABLE is pulled low again.

MUTE (Pin 8): This output is an open-drain N-channel device that sinks current to V_{SS} when TONE ENABLE is low and no tones are being generated. The device turns off when TONE ENABLE is high.

D0, D1, D2, D3 (Pins 9, 10, 11, 12): These are the inputs for binary-coded data, which is latched in on the rising edge of TONE ENABLE. Data must meet the timing specifications of Figure 2. At all other times these inputs are ignored and may be multiplexed with other system functions.

TONE OUT (Pin 14): This output is the open emitter of an NPN transistor, the collector of which is connected internally to V_{DD} . When an external load resistor is connected from TONE OUT to V_{SS} , the output voltage on this pin is the sum of the high and low group tones superimposed on a DC offset. When not generating tones, this output transistor is turned off to minimize the device idle current.

SINGLE TONE ENABLE (Pin 3): This input has an internal pull-up resistor. When pulled to V_{SS} , the device is in single tone mode and only a single tone will be generated at pin 14 (for testing purposes). For normal operation, leave this pin open-circuit or pull to V_{DD} .

GROUP SELECT (Pin 4): This pin is used to select the high group or low group frequency when the device is in single tone mode. It has an internal pull-up resistor. Leaving this pin open-circuit or pulling it to V_{DD} will generate the high group, while pulling to V_{SS} will generate the low group frequency at the TONE OUT pin.

TABLE II. Functional Truth Table

Keyboard Equivalent	Data Inputs				TONE ENABLE	TONES OUT		MUTE
	D3	D2	D1	D0		f _L (Hz)	f _H (Hz)	
X	X	X	X	X	0	0V	0V	0V
1	0	0	0	1	↗	697	1209	O/C
2	0	0	1	0	↗	697	1336	O/C
3	0	0	1	1	↗	697	1477	O/C
4	0	1	0	0	↗	770	1209	O/C
5	0	1	0	1	↗	770	1336	O/C
6	0	1	1	0	↗	770	1477	O/C
7	0	1	1	1	↗	852	1209	O/C
8	1	0	0	0	↗	852	1336	O/C
9	1	0	0	1	↗	852	1477	O/C
0	1	0	1	0	↗	941	1336	O/C
*	1	0	1	1	↗	941	1209	O/C
#	1	1	0	0	↗	941	1477	O/C
A	1	1	0	1	↗	697	1633	O/C
B	1	1	1	0	↗	770	1633	O/C
C	1	1	1	1	↗	852	1633	O/C
D	0	0	0	0	↗	941	1633	O/C

Timing Diagram

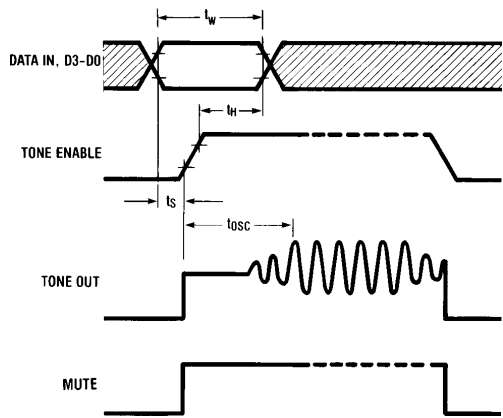
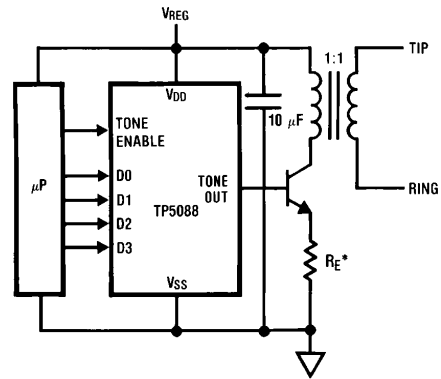

FIGURE 2

TL/H/5004-3

Typical Application



*Adjust R_E for desired tone amplitude.

FIGURE 3

TL/H/5004-4

Physical Dimensions inches (millimeters)

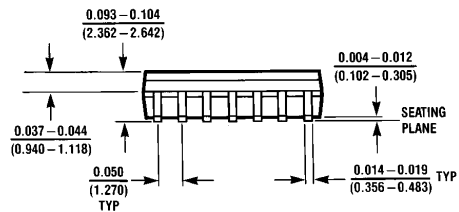
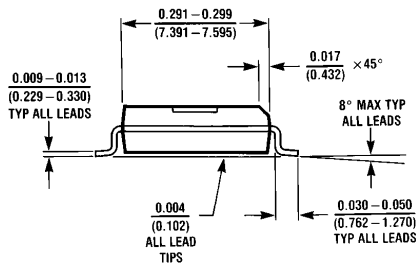
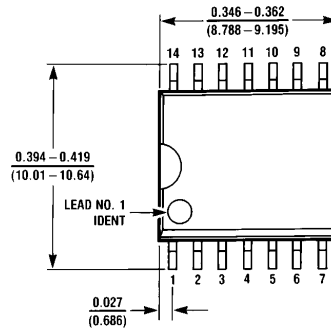

M14B (REV D)

Order Number TP5088WM
NS Package Number M14B

Physical Dimensions inches (millimeters) (Continued)

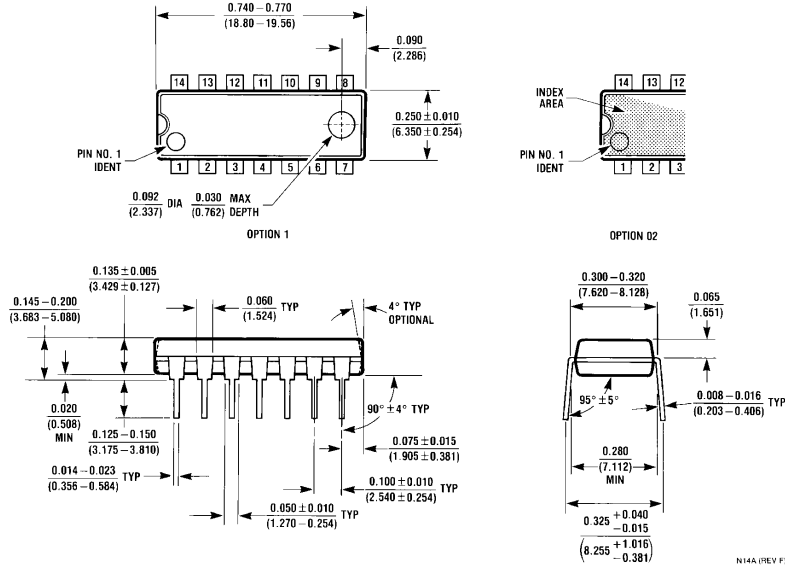

Molded Dual-In-Line (N)
Order Number TP5088N
NS Package Number N14A

LIFE SUPPORT POLICY

NATIONAL'S PRODUCTS ARE NOT AUTHORIZED FOR USE AS CRITICAL COMPONENTS IN LIFE SUPPORT DEVICES OR SYSTEMS WITHOUT THE EXPRESS WRITTEN APPROVAL OF THE PRESIDENT OF NATIONAL SEMICONDUCTOR CORPORATION. As used herein:

1. Life support devices or systems are devices or systems which, (a) are intended for surgical implant into the body, or (b) support or sustain life, and whose failure to perform, when properly used in accordance with instructions for use provided in the labeling, can be reasonably expected to result in a significant injury to the user.
2. A critical component is any component of a life support device or system whose failure to perform can be reasonably expected to cause the failure of the life support device or system, or to affect its safety or effectiveness.



National Semiconductor Corporation
 1111 West Bardin Road
 Arlington, TX 76017
 Tel: 1(800) 272-9959
 Fax: 1(800) 737-7018

National Semiconductor Europe
 Fax: (+49) 0-180-530 85 86
 Email: cnjwge@tevm2.nsc.com
 Deutsch Tel: (+49) 0-180-530 85 85
 English Tel: (+49) 0-180-532 78 32
 Français Tel: (+49) 0-180-532 93 58
 Italiano Tel: (+49) 0-180-534 16 80

National Semiconductor Hong Kong Ltd.
 13th Floor, Straight Block,
 Ocean Centre, 5 Canton Rd.
 Tsimshatsui, Kowloon
 Hong Kong
 Tel: (852) 2737-1600
 Fax: (852) 2736-9960

National Semiconductor Japan Ltd.
 Tel: 81-043-299-2309
 Fax: 81-043-299-2408

National does not assume any responsibility for use of any circuitry described, no circuit patent licenses are implied and National reserves the right at any time without notice to change said circuitry and specifications.