

- **Low  $r_{DS(on)}$  . . . 5  $\Omega$  Typical**
- **Eight Power DMOS Transistor Outputs of 100-mA Continuous Current**
- **210-mA Current Limit Capability**
- **Drain Output ESD Protection . . . 3000 V**
- **Output Clamp Voltage . . . 40 V**

### description

The TPIC2810 device is a monolithic, medium-voltage, low-current, 8-bit shift register design to drive low-side switched resistive loads such as LEDs. The device is not recommended for switching inductive loads.

This device contains an 8-bit, serial-in, parallel-out shift register that feeds an 8-bit D-type storage register. Data transfers through the shift register via an I<sup>2</sup>C bus interface. Data is transferred into the data shift register only after the group ID and device address have been verified. The subaddress directs the I<sup>2</sup>C bus interface to read or write data to the device or transfer data to the output. When output enable ( $\overline{G}$ ) is held high, all drain outputs are off. When  $\overline{G}$  is held low, data from the output storage register is transparent to the output buffers. When data in the output buffers is low, the DMOS transistor outputs are off. When data is high, the DMOS transistor outputs have sink-current capability.

The TPIC2810 device has an internal power-up clear to initialize all registers to an off state when power is applied to the device. It also has a thermal sensor to monitor the die temperature and shut the drain outputs off, if an over current condition occurs.

Outputs are low-side, open-drain DMOS transistors with output ratings of 40 V and 100 mA continuous sink-current capability. Each output provides a 210-mA maximum current limit at  $T_C = 25^\circ\text{C}$ . The current limit decreases as the junction temperature increases for additional device protection. The device also provides up to 3000 V of ESD protection on output terminals and 2000 V of ESD protection on input terminals when tested using the human-body model.

The TPIC2810 device is characterized for operation over the operating case temperature range of  $-40^\circ\text{C}$  to  $125^\circ\text{C}$ .

**D PACKAGE  
(TOP VIEW)**

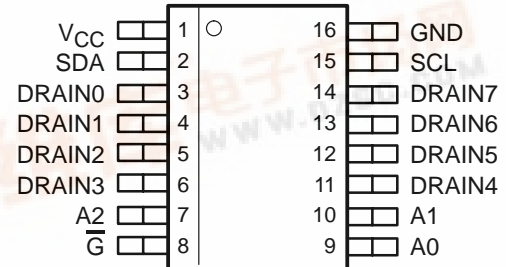

Please be aware that an important notice concerning availability, standard warranty, and use in critical applications of Texas Instruments semiconductor products and disclaimers thereto appears at the end of this data sheet.

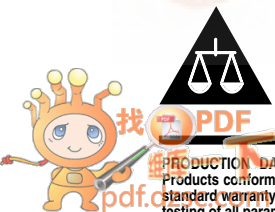

# TPIC2810

## 8-BIT LED DRIVER WITH I<sup>2</sup>C INTERFACE

SLIS109A – DECEMBER 2001 – REVISED SEPTEMBER 2002

### functional block diagram

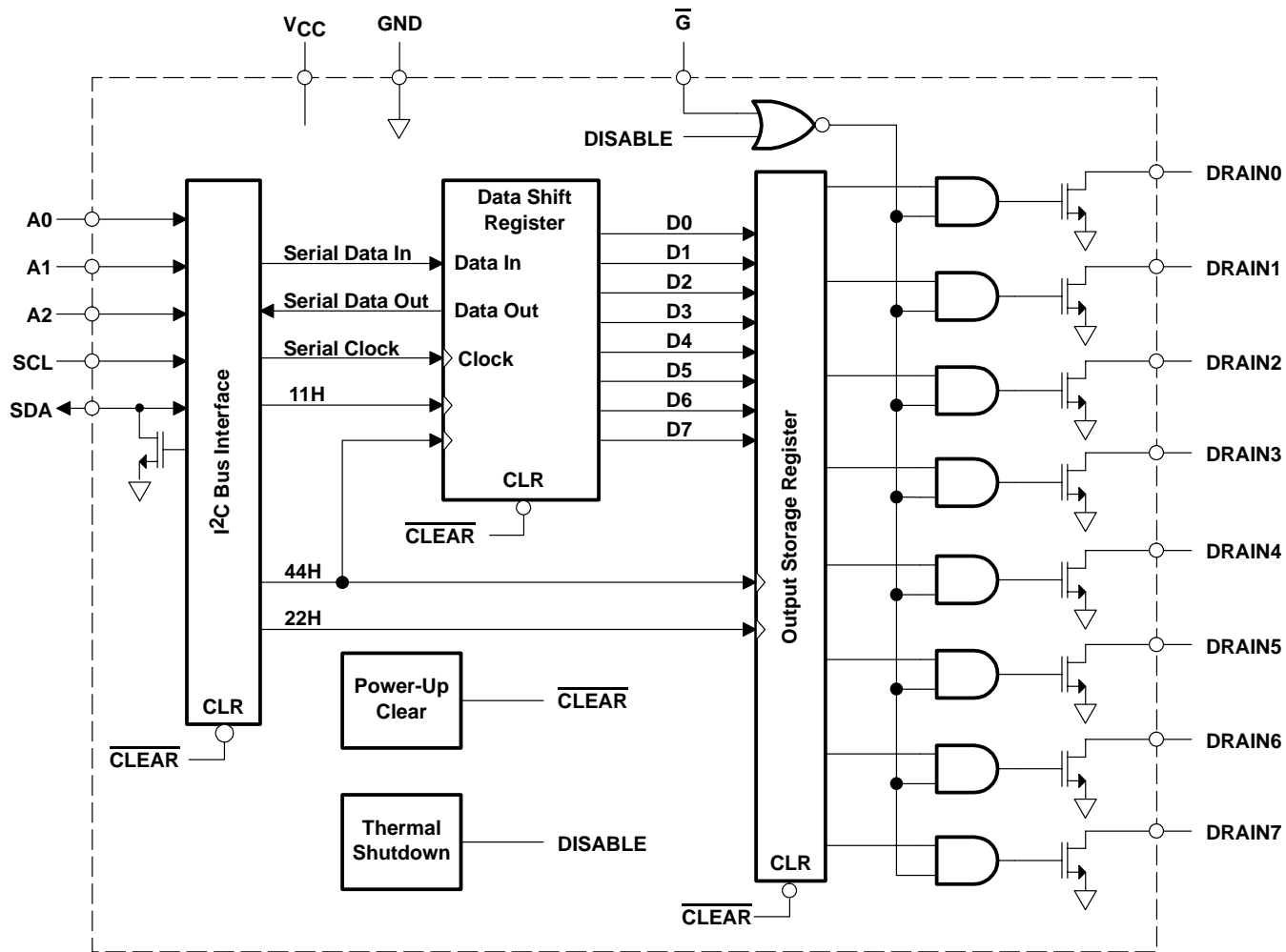

See the *TPIC2810 subaddress and I<sup>2</sup>C protocol definition* section of this data sheet for definition of the 11H, 22H, and 44H control signals.

# TPIC2810 8-BIT LED DRIVER WITH I<sup>2</sup>C INTERFACE

SLIS109A – DECEMBER 2001 – REVISED SEPTEMBER 2002

## Terminal Functions

TERMINAL NAME	NO.	I/O	DESCRIPTION
A0	9	I	Address input 0
A1	10	I	Address input 1
A2	7	I	Address input 2
DRAIN0	3	O	FET drain outputs. The DRAIN terminals are low-side switches for resistive loads.
DRAIN1	4		
DRAIN2	5		
DRAIN3	6		
DRAIN4	11		
DRAIN5	12		
DRAIN6	13		
DRAIN7	14		
$\overline{G}$	8	I	Output enable. Active low input enables output FETs when low and disables output FETs when high.
GND	16	O	Ground
SCL	15	I	Serial clock
SDA	2	I/O	Open drain, bidirectional serial data terminal
V <sub>CC</sub>	1	I	Supply voltage input

### schematic of inputs and outputs

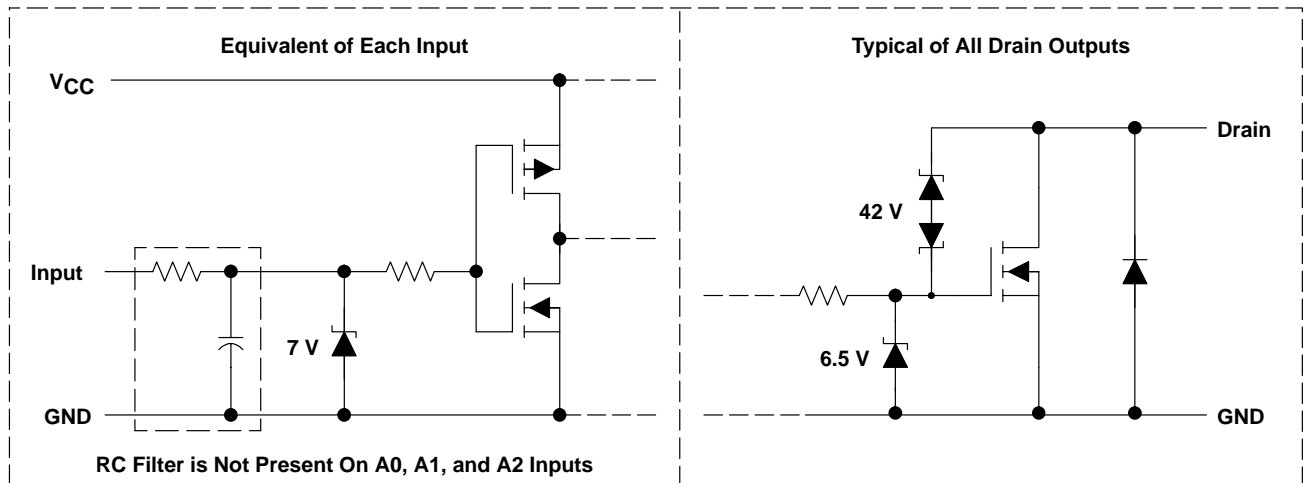

# TPIC2810

## 8-BIT LED DRIVER WITH I<sup>2</sup>C INTERFACE

SLIS109A – DECEMBER 2001 – REVISED SEPTEMBER 2002

### absolute maximum ratings over the recommended operating case temperature range (unless otherwise noted)†

Logic supply voltage range, $V_{CC}$ (see Note 1)	7 V
Logic input voltage range, $V_I$	-0.3 V to 7 V
Power DMOS drain-to-source voltage, $V_{DS}$ (see Note 2)	40 V
Continuous source-to-drain diode anode current	210 mA
Pulsed source-to-drain diode anode current (see Note 3)	420 mA
Pulsed drain current, each output, all outputs on, $I_D$ , $T_C = 25^\circ\text{C}$ (see Note 3)	210 mA
Peak drain current, single output, $I_{DM}$ , $T_C = 25^\circ\text{C}$ (see Note 3)	210 mA
Continuous total dissipation	See Dissipation Rating Table
Operating virtual junction temperature range, $T_J$	-40°C to 150°C
Operating case temperature range, $T_C$	-40°C to 125°C
Storage temperature range, $T_{stg}$	-65°C to 150°C

† Stresses beyond those listed under “absolute maximum ratings” may cause permanent damage to the device. These are stress ratings only, and functional operation of the device at these or any other conditions beyond those indicated under “recommended operating conditions” is not implied. Exposure to absolute-maximum-rated conditions for extended periods may affect device reliability.

- NOTES:
1. All voltage values are with respect to GND.
  2. Each power DMOS source is internally connected to GND.
  3. Pulse duration  $\leq 100 \mu\text{s}$  and duty cycle  $\leq 2\%$ .

DISSIPATION RATING TABLE

PACKAGE	$T_C = 25^\circ\text{C}$ POWER RATING	DERATING FACTOR ABOVE $T_C = 25^\circ\text{C}$	$T_C = 125^\circ\text{C}$ POWER RATING
D	1087 mW	8.7 mW/°C	217 mW

### recommended operating conditions

	MIN	MAX	UNIT
Logic supply voltage, $V_{CC}$	3.0	5.5	V
High-level input voltage, $V_{IH}$	$0.7V_{CC}$		V
Low-level input voltage, $V_{IL}$	$0.3V_{CC}$		V
Pulse drain output current, $T_C = 25^\circ\text{C}$ , $V_{CC} = 5 \text{ V}$ , all outputs on (see Notes 3 and 4 and Figure 8)	210		mA
Operating case temperature, $T_C$	-40	125	°C

- NOTES:
3. Pulse duration  $\leq 100 \mu\text{s}$  and duty cycle  $\leq 2\%$ .
  4. Technique must limit  $T_J - T_C$  to 10°C maximum.

# TPIC2810

## 8-BIT LED DRIVER WITH I<sup>2</sup>C INTERFACE

SLIS109A – DECEMBER 2001 – REVISED SEPTEMBER 2002

### electrical characteristics, $V_{CC} = 5\text{ V}$ , $T_C = 25^\circ\text{C}$ (unless otherwise noted)

PARAMETER		TEST CONDITIONS		MIN	TYP	MAX	UNIT
$V_{CC}$	Logic supply voltage			3		5.5	V
$V_{(BR)DSX}$	Drain-to-source breakdown voltage	$I_D = 1\text{ mA}$		40			V
$V_{SD}$	Source-to-drain diode forward voltage	$I_F = 100\text{ mA}$			0.85	1.2	V
$V_{PUC}$	Power-up clear voltage	$V_{CC}$ rising no load,	See Note 5			2.84	V
$I_{IH}$	High-level input current	$V_{CC} = 5.5\text{ V}$ ,	$V_I = V_{CC}$			1	$\mu\text{A}$
$I_{IL}$	Low-level input current	$V_{CC} = 5.5\text{ V}$ ,	$V_I = 0$			-1	$\mu\text{A}$
$V_{HYS}$	Digital input hysteresis				1.1		V
$I_{CC}$	Logic supply current	$V_{CC} = 5.5\text{ V}$	All outputs off		0.62	1	mA
			All outputs on		0.7	1	
$I_{CC}(\text{FRQ})$	Logic supply current at frequency	$f_{SCL} = 100\text{ kHz}$ , All outputs off,	$C_L = 30\text{ pF}$ , See Figure 3		0.74	1	mA
$I_{OL}$	Low level output current; SDA	$V_{OL} = 0.4\text{ V}$			13		mA
$I_L$	Leakage current; SDA	$V_I = V_{CC}$		-1		1	$\mu\text{A}$
$I_N$	Nominal current	$V_{DS(\text{on})} = 0.5\text{ V}$ , $T_C = 85^\circ\text{C}$ ,	$I_N = I_D$ , See Notes 4, 6, 7		75		mA
$I_{DSX}$	Off-state drain current	$V_{DS} = 30\text{ V}$	$V_{CC} = 5.5\text{ V}$		0.3	0.6	$\mu\text{A}$
		$V_{DS} = 30\text{ V}$ , $T_C = 125^\circ\text{C}$			0.3	0.6	
$T_{TSD}$	Thermal shutdown set points			160			$^\circ\text{C}$
$T_{HYS}$	Thermal shutdown hysteresis			10	20	30	$^\circ\text{C}$
$r_{DS(\text{on})}$	Static drain-source on-state resistance	$I_D = 100\text{ mA}$ , $V_{CC} = 3\text{ V}$	See Notes 4 and 6 and Figures 4 and 5		8.0	10.8	$\Omega$
		$I_D = 100\text{ mA}$ , $V_{CC} = 4.5\text{ V}$			5.1	6.9	
		$I_D = 100\text{ mA}$ , $V_{CC} = 3.0\text{ V}$ , $T_C = 125^\circ\text{C}$			13.0	18.2	
		$I_D = 100\text{ mA}$ , $V_{CC} = 4.5\text{ V}$ , $T_C = 125^\circ\text{C}$			8.0	11.2	

- NOTES: 4. Technique must limit  $T_J - T_C$  to  $10^\circ\text{C}$  maximum  
5. The power-up clear resets the I<sup>2</sup>C interface and clears all outputs.  
6. These parameters are measured with voltage-sensing contacts separate from the current-carrying contacts.  
7. Nominal current is defined for a consistent comparison between devices from different sources. It is the current that produces a voltage of 0.5 V at  $T_C = 85^\circ\text{C}$ .

# TPIC2810

## 8-BIT LED DRIVER WITH I<sup>2</sup>C INTERFACE

SLIS109A – DECEMBER 2001 – REVISED SEPTEMBER 2002

**switching characteristics, V<sub>CC</sub> = 5 V, T<sub>C</sub> = 25°C, C<sub>L</sub> = 100 pF (unless otherwise noted)**

PARAMETER		TEST CONDITIONS	MIN	TYP	MAX	UNIT
t <sub>PLH</sub>	Propagation delay time, low-to-high-level output from $\overline{G}$	C <sub>L</sub> = 30 pF, I <sub>D</sub> = 75 mA, See Figures 1, 2, and 6		1.15		μs
t <sub>PHL</sub>	Propagation delay time, high-to-low-level output from G			0.64		
t <sub>r(OUT)</sub>	Rise time, drain output			1.05		
t <sub>f(OUT)</sub>	Fall time, drain output			0.89		
f(SCL)	Serial clock frequency			100		kHz
				400		
					2	
t(BUF)	Bus free time between stop and start condition	SCL = 100 kHz	4.7			μs
		SCL = 400 kHz	1.3			
t(SP)	Tolerable spike width on bus			50		ns
t <sub>pd(ACK)</sub>	SCL low to data out valid (acknowledge)			120		ns
t <sub>LOW</sub>	SCL low time	SCL = 100 kHz	4.7			μs
		SCL = 400 kHz	1.3			
		SCL = 2 MHz	250			ns
t <sub>HIGH</sub>	SCL high time	SCL = 100 kHz	4.0			μs
		SCL = 400 kHz	600			
		SCL = 2 MHz	200			ns
t <sub>su(DAT)</sub>	SDA → SCL setup time	SCL = 100 kHz	250			ns
		SCL = 400 kHz	100			
		SCL = 2 MHz	10			
t <sub>su(STA)</sub>	Start condition setup time	SCL = 100 kHz	4.7			μs
		SCL = 400 kHz	600			
		SCL = 2 MHz	300			ns
t <sub>su(STO)</sub>	Stop condition setup time	SCL = 100 kHz	4			μs
		SCL = 400 kHz	600			
		SCL = 2 MHz	140			ns
t <sub>h(DAT)</sub>	SDA → SCL hold time		50			ns
t <sub>h(STA)</sub>	Start condition hold time	SCL = 100 kHz	4			μs
		SCL = 400 kHz	600			
		SCL = 2 MHz	160			ns
t <sub>r(SCL)</sub>	Rise time of SCL signal	SCL = 100 kHz		1000		ns
		SCL = 400 kHz		300		
		SCL = 2 MHz		70		
t <sub>f(SCL)</sub>	Fall time of SCL signal	SCL = 100 kHz		300		ns
		SCL = 400 kHz		300		
		SCL = 2 MHz		70		
t <sub>r(SDA)</sub>	Rise time of SDA signal	SCL = 100 kHz		1000		ns
		SCL = 400 kHz		300		
		SCL = 2 MHz		70		
t <sub>f(SDA)</sub>	Fall time of SDA signal	SCL = 100 kHz		300		ns
		SCL = 400 kHz		300		
		SCL = 2 MHz		140		

# TPIC2810 8-BIT LED DRIVER WITH I<sup>2</sup>C INTERFACE

SLIS109A – DECEMBER 2001 – REVISED SEPTEMBER 2002

## thermal resistance

PARAMETER		TEST CONDITIONS	MIN	MAX	UNIT
R <sub>θJA</sub>	Junction-to-ambient thermal resistance	All 8 outputs with equal power		115	°C/W

## PARAMETER MEASUREMENT INFORMATION

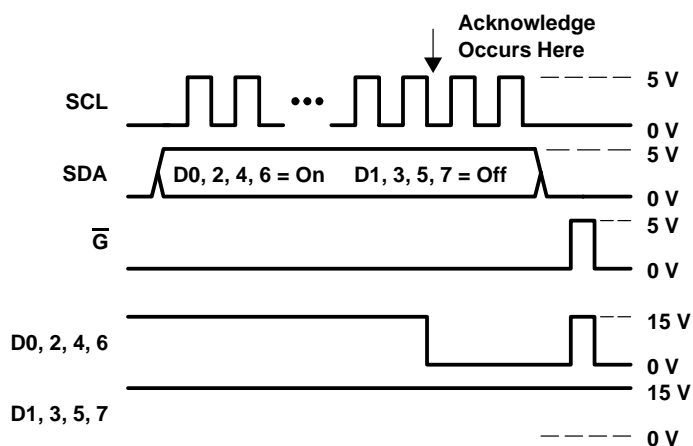
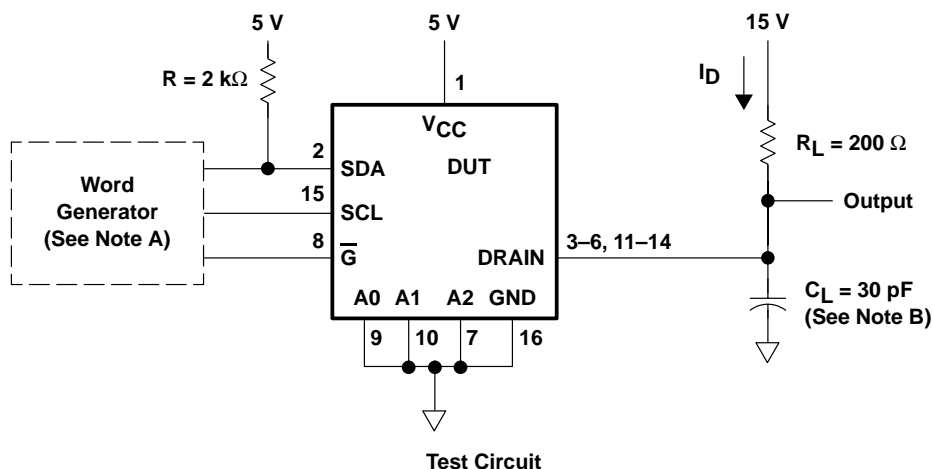

- NOTES: A. The word generator has the following characteristics:  $t_r \leq 30$  ns,  $t_f \leq 30$  ns, pulsed repetition rate (PRR) = 400 kHz,  $Z_O = 50$   $\Omega$ .  
 B.  $C_L$  includes probe and jig capacitance.

**Figure 1. Resistive-Load Test Circuit and Voltage Waveforms**

# TPIC2810 8-BIT LED DRIVER WITH I<sup>2</sup>C INTERFACE

SLIS109A – DECEMBER 2001 – REVISED SEPTEMBER 2002

## PARAMETER MEASUREMENT INFORMATION

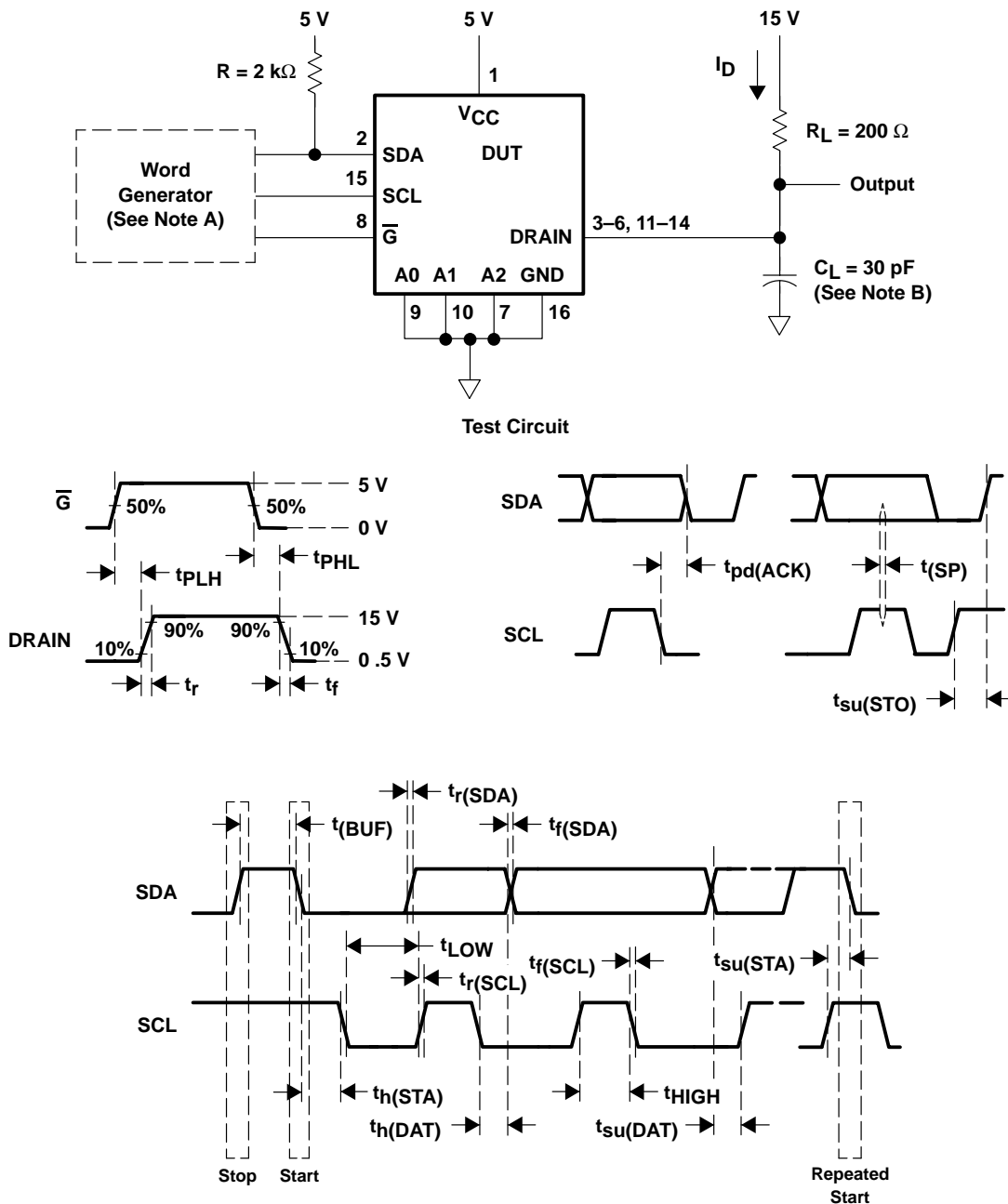

- NOTES: A. The word generator has the following characteristics: t<sub>r</sub> ≤ 30 ns, t<sub>f</sub> ≤ 30 ns, pulsed repetition rate (PRR) = 400 kHz, Z<sub>O</sub> = 50 Ω.  
B. C<sub>L</sub> includes probe and jig capacitance.

Figure 2. Test Circuit, Switching Times and Voltage Waveforms



TYPICAL CHARACTERISTICS

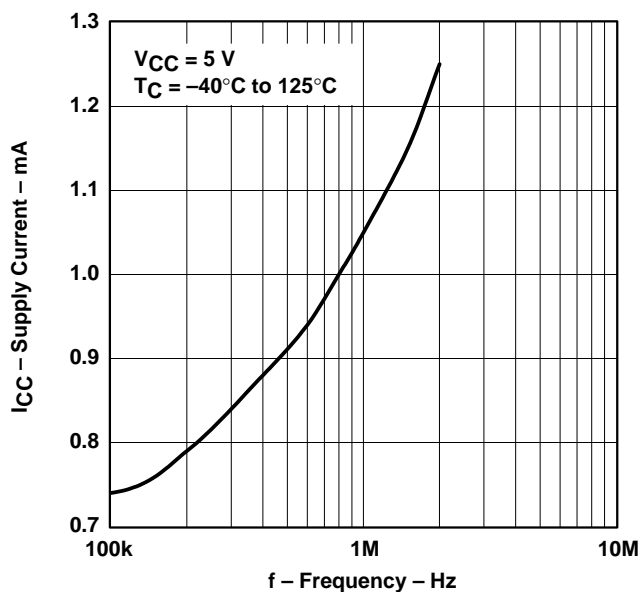

Figure 3. Supply Current vs Frequency

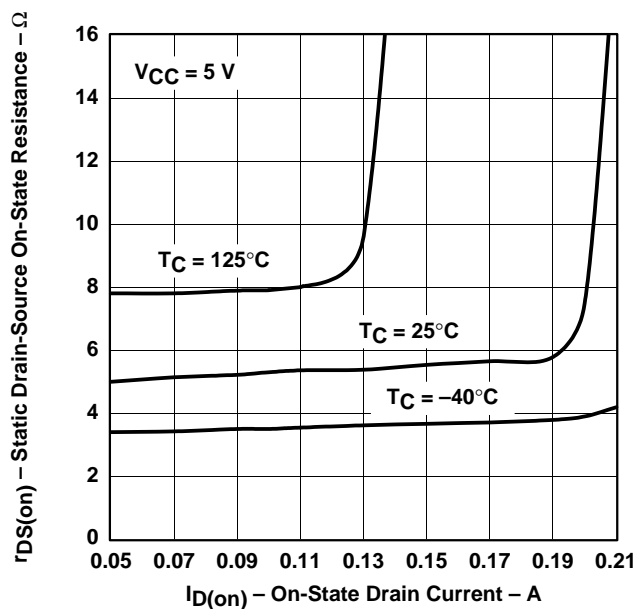

Figure 4. Static Drain-Source On-State Resistance vs On-State Drain Current

# TPIC2810 8-BIT LED DRIVER WITH I<sup>2</sup>C INTERFACE

SLIS109A – DECEMBER 2001 – REVISED SEPTEMBER 2002

## TYPICAL CHARACTERISTICS

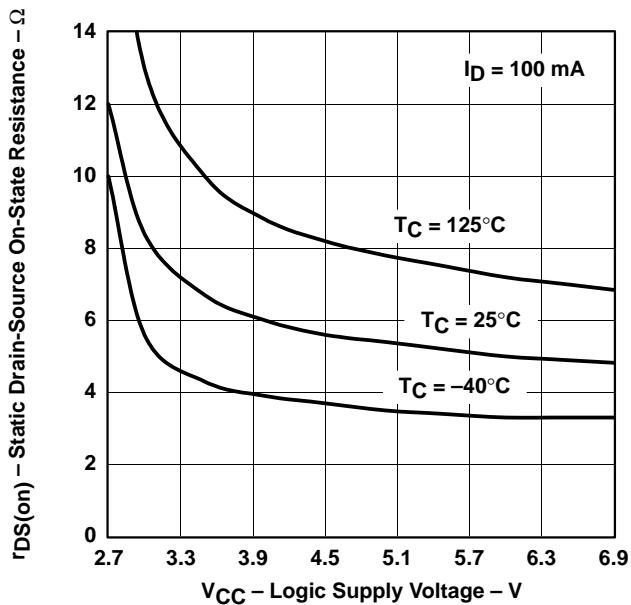

Figure 5. Static Drain-Source On-State Resistance vs Logic Supply Voltage

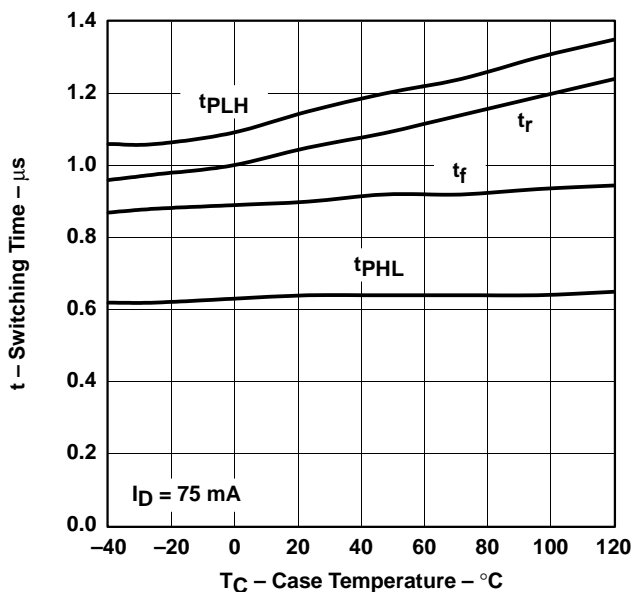

Figure 6. Switching Time vs Case Temperature

TYPICAL CHARACTERISTICS

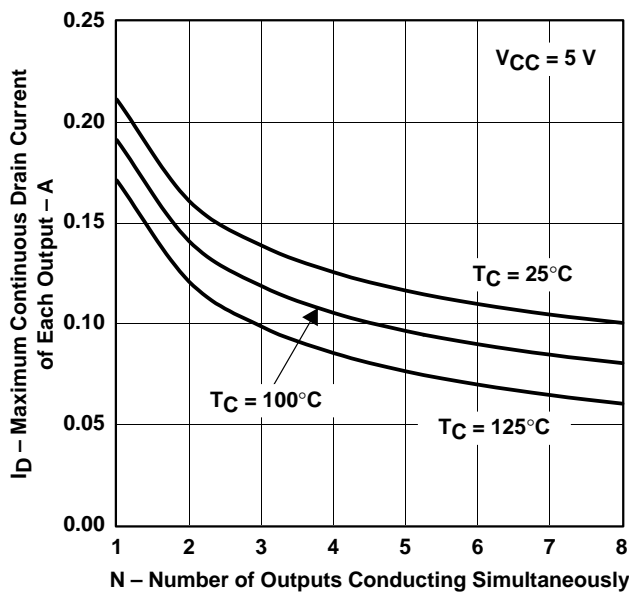

Figure 7. Maximum Continuous Drain Current Of Each Output vs Number Of Outputs Conducting Simultaneously

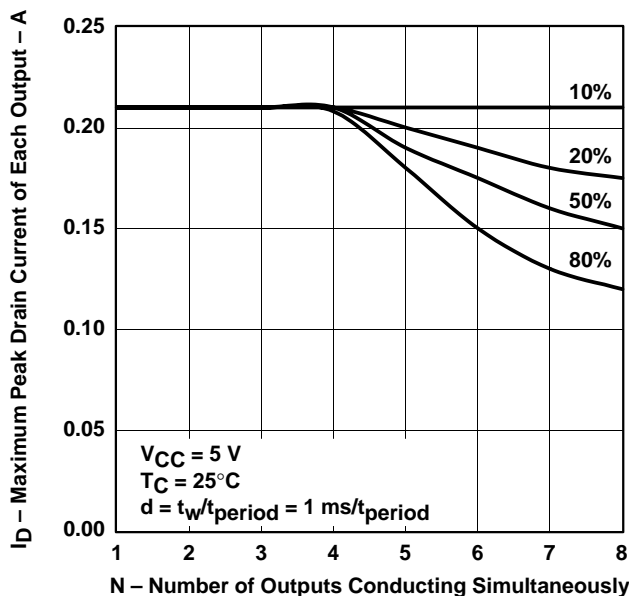

Figure 8. Maximum Peak Drain Current Of Each Output vs Number Of Outputs Conducting Simultaneously

# TPIC2810 8-BIT LED DRIVER WITH I<sup>2</sup>C INTERFACE

SLIS109A – DECEMBER 2001 – REVISED SEPTEMBER 2002

## THERMAL INFORMATION

### D PACKAGE†

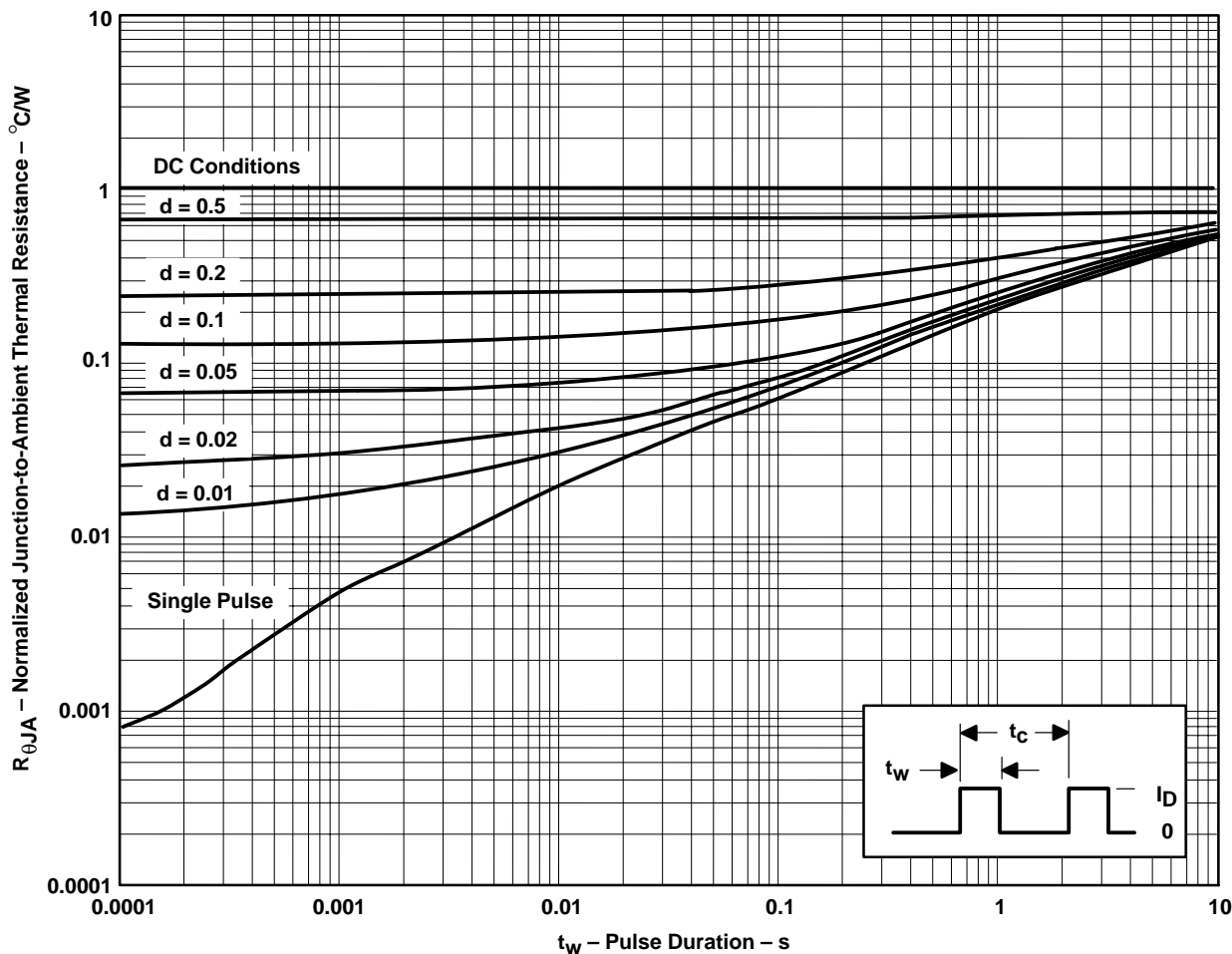

† Device mounted on FR4 printed-circuit board with no heat sink

- NOTES:  $Z_{\theta A}(t) = r(t) R_{\theta JA}$   
 $t_w$  = pulse duration  
 $t_c$  = cycle time  
 $d$  = duty cycle =  $t_w/t_c$

**Figure 9. Normalized Junction-to-Ambient Thermal Resistance vs Pulse Duration**

# TPIC2810 8-BIT LED DRIVER WITH I<sup>2</sup>C INTERFACE

SLIS109A – DECEMBER 2001 – REVISED SEPTEMBER 2002

## PRINCIPLES OF OPERATION

### TPIC2810 subaddress and I<sup>2</sup>C protocol definition

#### subaddress definition:

##### Summary:

HEX Value	R/W Bit	Function
11H	1	Read data from the input register
11H	0	Write data to the data shift register, do not transfer to output register
22H	0	Command to transfer data from the data shift register to the output storage register
44H	0	Write data to the data shift register and transfer it to the output storage register immediately (extra load 22H command not needed)
Other	x	No action on undefined subaddresses

All other undefined subaddress values are not acknowledged.

#### register definition:

- The data shift register receives serial data from the I<sup>2</sup>C interface.
- The data shift register receives data from the input interface and holds it until it is transferred to the output storage register.
- The output storage register controls whether the FET is on or off.

### TPIC2810 I<sup>2</sup>C input interface protocol definition

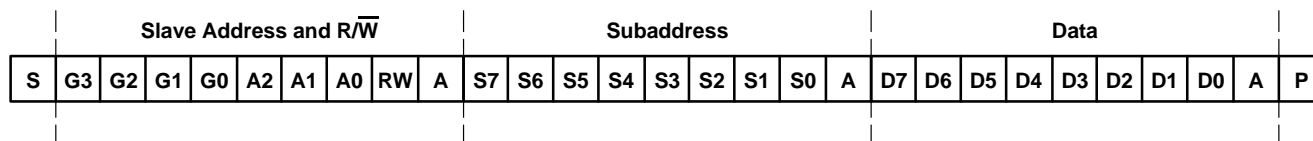

<b>S</b>	<b>Start Condition</b>
<b>G</b>	<b>Group ID: Defined as 1100</b>
<b>A(0:2)</b>	<b>Device Address Selectable Via Input Terminals</b>
<b>RW</b>	<b>Read/Write Select Bit</b>
<b>A</b>	<b>Acknowledge</b>
<b>Subaddress</b>	<b>Defined Per Subaddress Table</b>
<b>Data</b>	<b>Data to Be Loaded Into the Shift and Output Registers</b>
<b>P</b>	<b>Stop Condition</b>

# TPIC2810

## 8-BIT LED DRIVER WITH I<sup>2</sup>C INTERFACE

SLIS109A – DECEMBER 2001 – REVISED SEPTEMBER 2002

### PRINCIPLES OF OPERATION

#### Case 1: Read/Write serial data, but do not load output register

This case loads the data shift register with data via the I<sup>2</sup>C interface. Data is not transferred to the output storage register.

#### write operation:

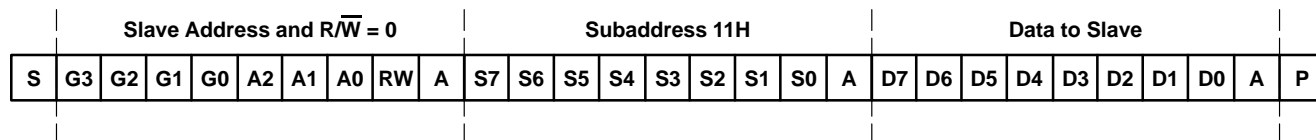

- G[3:0]: Fixed at 1100
- A[2:0]: Selectable Via Input Terminals
- RW: 0 = Write Shift Register
- Subaddress: 11H (0001 0001)
- Data: Output Data to the TPIC2810 Device
- Acknowledge: Occurs After Valid Address Byte, After the Subaddress Byte, and After the Data Byte

#### read operation:

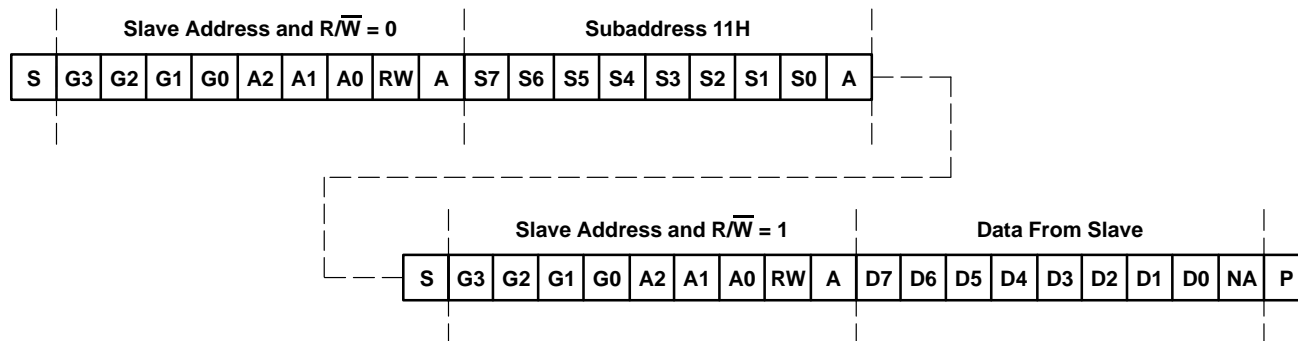

- G[3:0]: Fixed at 1100
- A[2:0]: Selectable Via Input Terminals
- RW: 1 = Read Shift Register (Note the Slave Address RW Bit = 0)
- Subaddress: 11H (0001 0001)
- Data: Input Data From the TPIC2810 Device
- Acknowledge: Occurs After Valid Address Byte and After the Subaddress Byte

# TPIC2810 8-BIT LED DRIVER WITH I<sup>2</sup>C INTERFACE

SLIS109A – DECEMBER 2001 – REVISED SEPTEMBER 2002

## PRINCIPLES OF OPERATION

### Case 2: Transfer serial data to output storage register

This case transfers data from the data shift register to the output storage register. The transfer must occur during the subaddress acknowledge bit and the data byte is ignored.

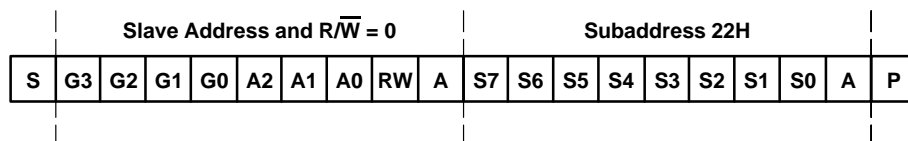

**G[3:0]:** Fixed at 1100  
**A[2:0]:** Selectable Via Input Terminals  
**RW:** 0 = Write Shift Register  
**Subaddress:** 22H (0010 0010)  
**Data:** Output Data to the TPIC2810 Device  
**Acknowledge:** Occurs After Valid Address Byte and After the Subaddress Byte

### Case 3: Read serial data and load output storage register

This case loads the data shift register with data via the I<sup>2</sup>C interface and transfers the data to output storage register, if  $R/\overline{W} = 0$ . The transfer occurs during the acknowledge bit following the data byte. Data byte and transfer to the output register is ignored if  $R/\overline{W} = 1$ .

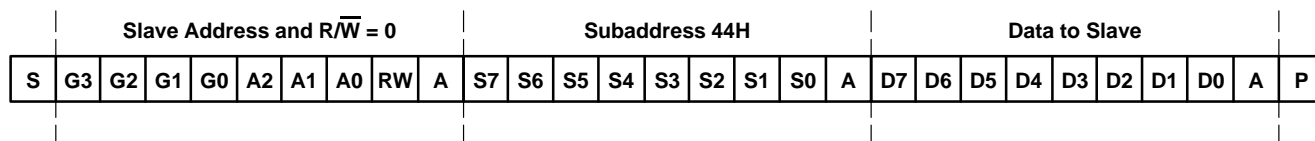

**G[3:0]:** Fixed at 1100  
**A[2:0]:** Selectable Via Input Terminals  
**RW:** 0 = Write Shift Register  
**Subaddress:** 44H (0100 0100)  
**Data:** Output Data to the TPIC2810 Device  
**Acknowledge:** Occurs After Valid Address Byte, After the Subaddress Byte and After the Data Byte

### Case 4: Undefined subaddress values

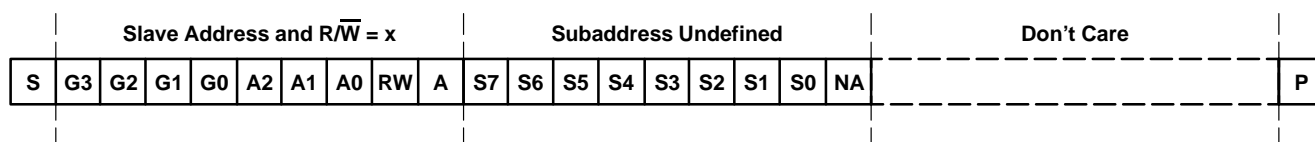

**G[3:0]:** Fixed at 1100  
**A[2:0]:** Selectable Via Input Terminals  
**RW:** Don't Care  
**Subaddress:** All Bit Combinations Except 11H, 22H, and 44H  
**Data:** Don't Care; Data Is Ignored  
**Acknowledge:** Occurs After Valid Address Byte, But Is Not Issued After an Undefined Subaddress Byte or After the Data Byte Following an Undefined Subaddress Byte

# TPIC2810

## 8-BIT LED DRIVER WITH I<sup>2</sup>C INTERFACE

SLIS109A – DECEMBER 2001 – REVISED SEPTEMBER 2002

### PRINCIPLES OF OPERATION

#### I<sup>2</sup>C bus operation

The I<sup>2</sup>C bus is a communications link between a controller and a series of slave terminals. The link is established using a two-wire bus consisting of a serial clock signal (SCL) and a serial data signal (SDA). The serial clock is sourced from the controller in all cases where the serial data signal is bidirectional for data communication between the controller and the slave terminals. Each device has an open drain output to transmit data on the serial data line. An external pullup resistor must be placed on the serial data signal to provide the high level portion of the data transmission.

Data transmission is initiated with a start bit from the controller as shown in Figure 10. Both the SCL and SDA signals must remain in a logic high state when the controller is not communicating with the slave devices. A start condition is recognized by the slave devices when the SDA line transitions from high to low during the high portion of the SCL signal. Upon reception of a start bit, the TPIC2810 device receives serial data on the SDA input and check for valid address and control information. If the appropriate group and address bits are set for the device, then the device issues an acknowledge pulse and prepares the receive subaddress data. The group ID for the TPIC2810 device is hard coded to be 1100. The slave address bits are set to correspond to the A(0:2) inputs for the device. Up to eight TPIC2810 devices can be placed on the bus. Subaddress data is decoded and responded to as per the *TPIC2810 subaddress and I<sup>2</sup>C protocol definition* section of this data sheet. Data transmission is complete by either the reception of a stop condition or the reception of the data word sent to the device. A stop condition is recognized as a low-to-high transition of the SDA input during the high portion of the SCL signal. All other transitions of the SDA line must occur during the low portion of the SCL signal.

An acknowledge is issued by the TPIC2810 device after the reception of valid address, subaddress and data words as per the *TPIC2810B subaddress and I<sup>2</sup>C protocol definition* section of this document. Reference Figure 10. The device acknowledges each byte of data that it receives from the controller.

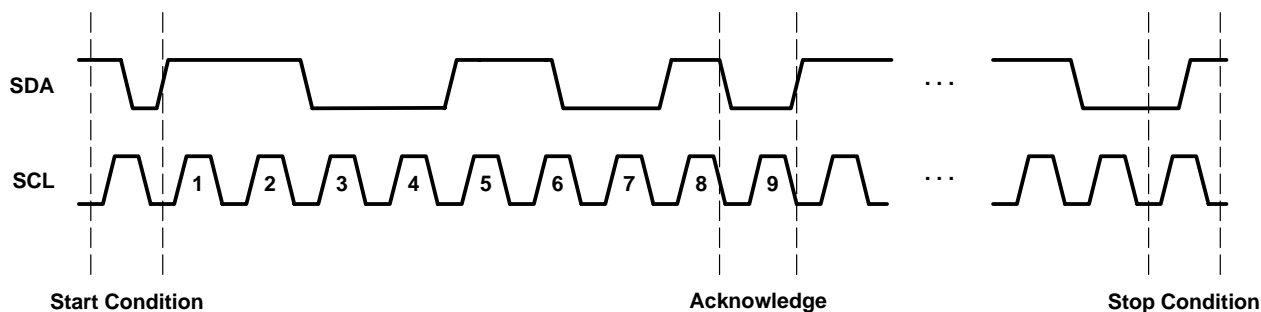

Figure 10. Start/Stop/Acknowledge Protocol



# TPIC2810 8-BIT LED DRIVER WITH I<sup>2</sup>C INTERFACE

SLIS109A – DECEMBER 2001 – REVISED SEPTEMBER 2002

## MECHANICAL DATA

**D (R-PDSO-G\*\*)**

**PLASTIC SMALL-OUTLINE PACKAGE**

8 PINS SHOWN

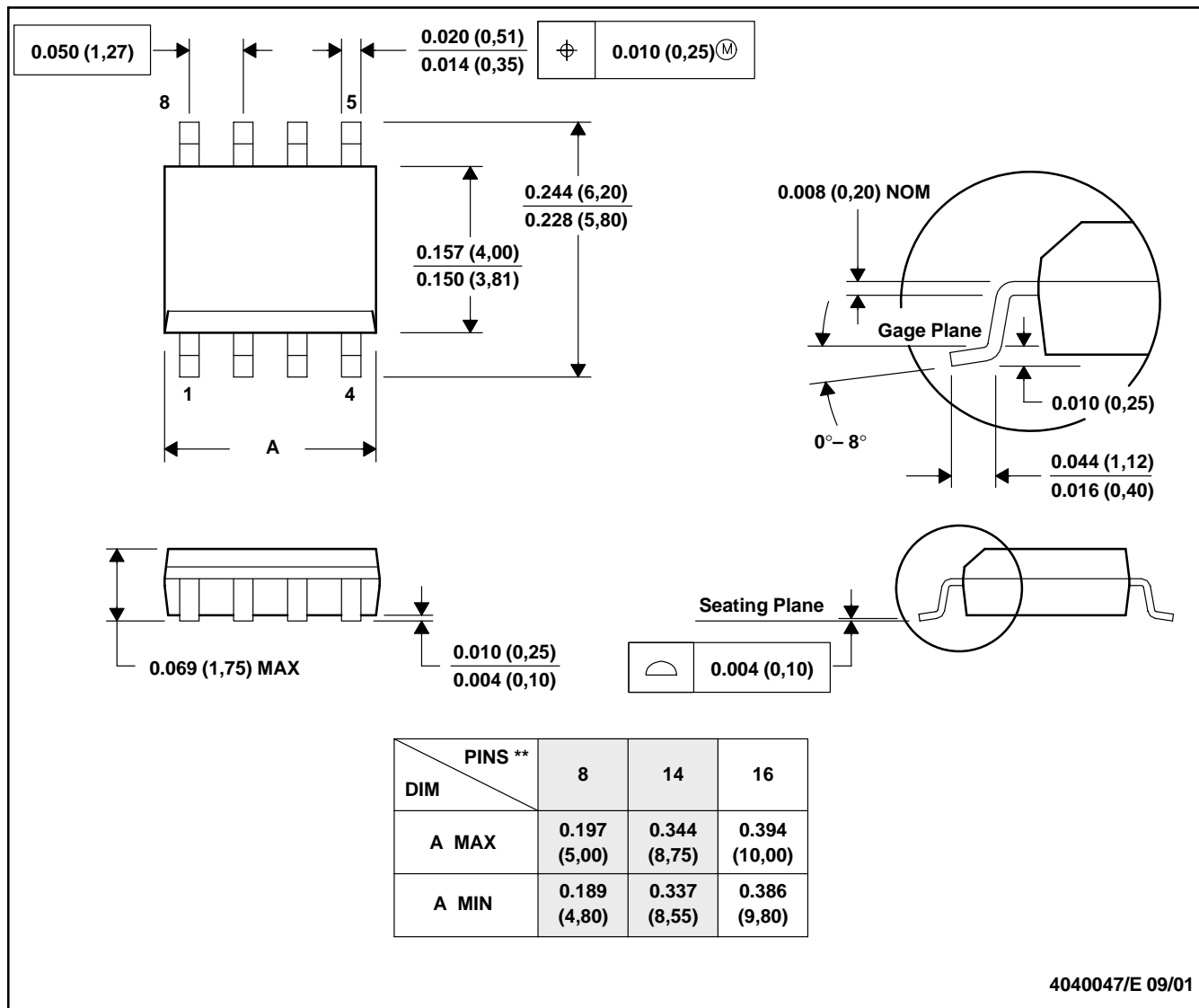

- NOTES: A. All linear dimensions are in inches (millimeters).  
 B. This drawing is subject to change without notice.  
 C. Body dimensions do not include mold flash or protrusion, not to exceed 0.006 (0,15).  
 D. Falls within JEDEC MS-012

## **IMPORTANT NOTICE**

Texas Instruments Incorporated and its subsidiaries (TI) reserve the right to make corrections, modifications, enhancements, improvements, and other changes to its products and services at any time and to discontinue any product or service without notice. Customers should obtain the latest relevant information before placing orders and should verify that such information is current and complete. All products are sold subject to TI's terms and conditions of sale supplied at the time of order acknowledgment.

TI warrants performance of its hardware products to the specifications applicable at the time of sale in accordance with TI's standard warranty. Testing and other quality control techniques are used to the extent TI deems necessary to support this warranty. Except where mandated by government requirements, testing of all parameters of each product is not necessarily performed.

TI assumes no liability for applications assistance or customer product design. Customers are responsible for their products and applications using TI components. To minimize the risks associated with customer products and applications, customers should provide adequate design and operating safeguards.

TI does not warrant or represent that any license, either express or implied, is granted under any TI patent right, copyright, mask work right, or other TI intellectual property right relating to any combination, machine, or process in which TI products or services are used. Information published by TI regarding third-party products or services does not constitute a license from TI to use such products or services or a warranty or endorsement thereof. Use of such information may require a license from a third party under the patents or other intellectual property of the third party, or a license from TI under the patents or other intellectual property of TI.

Reproduction of information in TI data books or data sheets is permissible only if reproduction is without alteration and is accompanied by all associated warranties, conditions, limitations, and notices. Reproduction of this information with alteration is an unfair and deceptive business practice. TI is not responsible or liable for such altered documentation.

Resale of TI products or services with statements different from or beyond the parameters stated by TI for that product or service voids all express and any implied warranties for the associated TI product or service and is an unfair and deceptive business practice. TI is not responsible or liable for any such statements.

### **Mailing Address:**

Texas Instruments  
Post Office Box 655303  
Dallas, Texas 75265