



# SILICON N-CHANNEL RF POWER MOSFET

## DESCRIPTION:

The **TPV596** is Designed for Common Source Push Pull RF Power Applications up to 400 MHz.

## FEATURES:

- $P_G = 12$  dB min. at 0.5 W/ 860 MHz
- Common Emitter
- **Omnigold™** Metallization System

## MAXIMUM RATINGS

$I_C$	0.7 A
$V_{CE}$	24 V
$T_J$	-65 °C to +200 °C
$T_{STG}$	-65 °C to +150 °C
$P_{DISS}$	8.75 W @ $T_C = 25$ °C

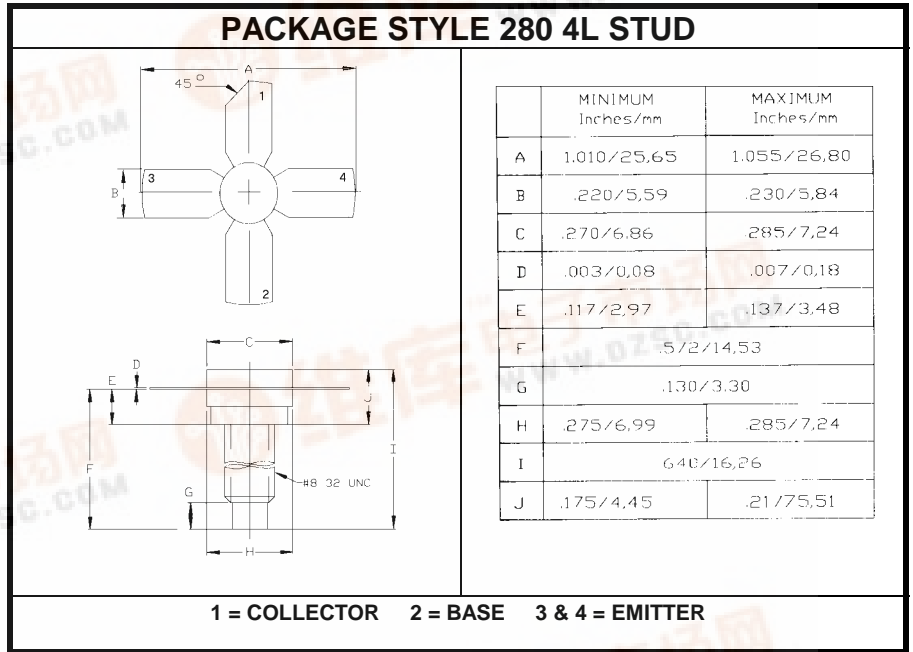

## CHARACTERISTICS $T_C = 25$ °C

SYMBOL	TEST CONDITIONS	MINIMUM	TYPICAL	MAXIMUM	UNITS
$BV_{CEO}$	$I_C = 20$ mA	24			V
$BV_{CBO}$	$I_C = 1.0$ mA	45			V
$BV_{CER}$	$I_C = 20$ mA $R_{BE} = 10$ Ω	50			V
$BV_{EBO}$	$I_E = 0.25$ mA	3.5			V
$I_{CBO}$	$V_{CB} = 28$ V			0.45	mA
$h_{FE}$	$I_C = 100$ mA $V_{CE} = 5.0$ V	15		120	---
$C_{OB}$	$V_{CB} = 28$ V $f = 1.0$ MHz			5.0	pF
$P_G$	$V_{CE} = 20$ V $I_E = 0.22$ A $f = 860$ MHz	11.5	12		dB

