



TS321

LOW POWER SINGLE OPERATIONAL AMPLIFIER

- LARGE OUTPUT VOLTAGE SWING :
0 to 3.5V min. (@V_{CC} = 5V)
- LOW SUPPLY CURRENT : 300µA
- LOW INPUT BIAS CURRENT : 20nA
- LOW INPUT OFFSET VOLTAGE : 2mV max.
- WIDE POWER SUPPLY RANGE :
SINGLE SUPPLY : +3V TO +30V
DUAL SUPPLIES : ±1.5V TO ±15V
- STABLE WITH HIGH CAPACITIVE LOADS

DESCRIPTION

The TS321 is intended for cost sensitive applications where space saving is of great importance. This bipolar Op-Amp offers the benefits of a reduced component size (SOT23-5 package), with specifications that match (or better) industry standard devices (like the popular LM358A, LM324, etc.). The TS321 has an input common mode range (Vicm) that includes ground, therefore can be employed in single supply applications.

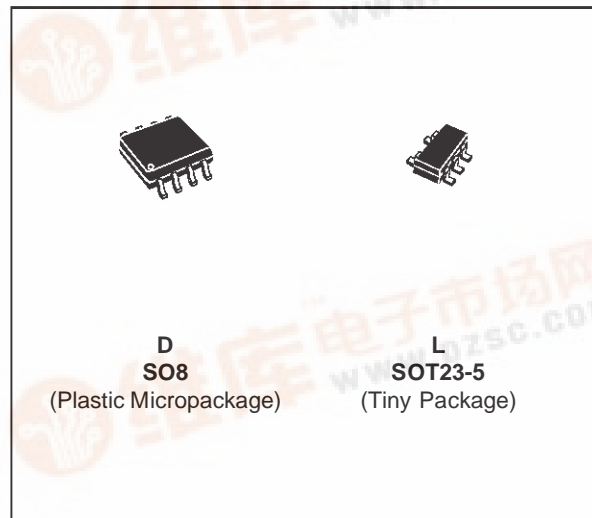

D
SO8
(Plastic Micropackage)

L
SOT23-5
(Tiny Package)

ORDER CODES

Part Number	Temperature Range	Package		SOT Marking
		D	L	
TS321I	-40°C, +125°C	•	•	K401
TS321AI		•	•	K402

PIN CONNECTIONS (top view)

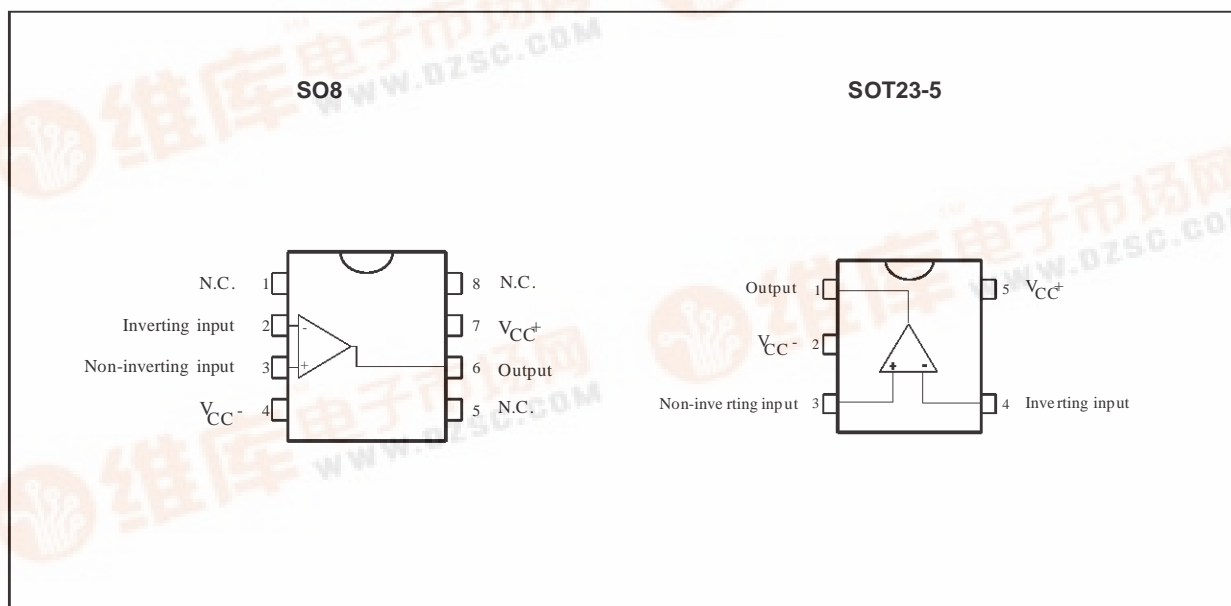

SCHEMATIC DIAGRAM

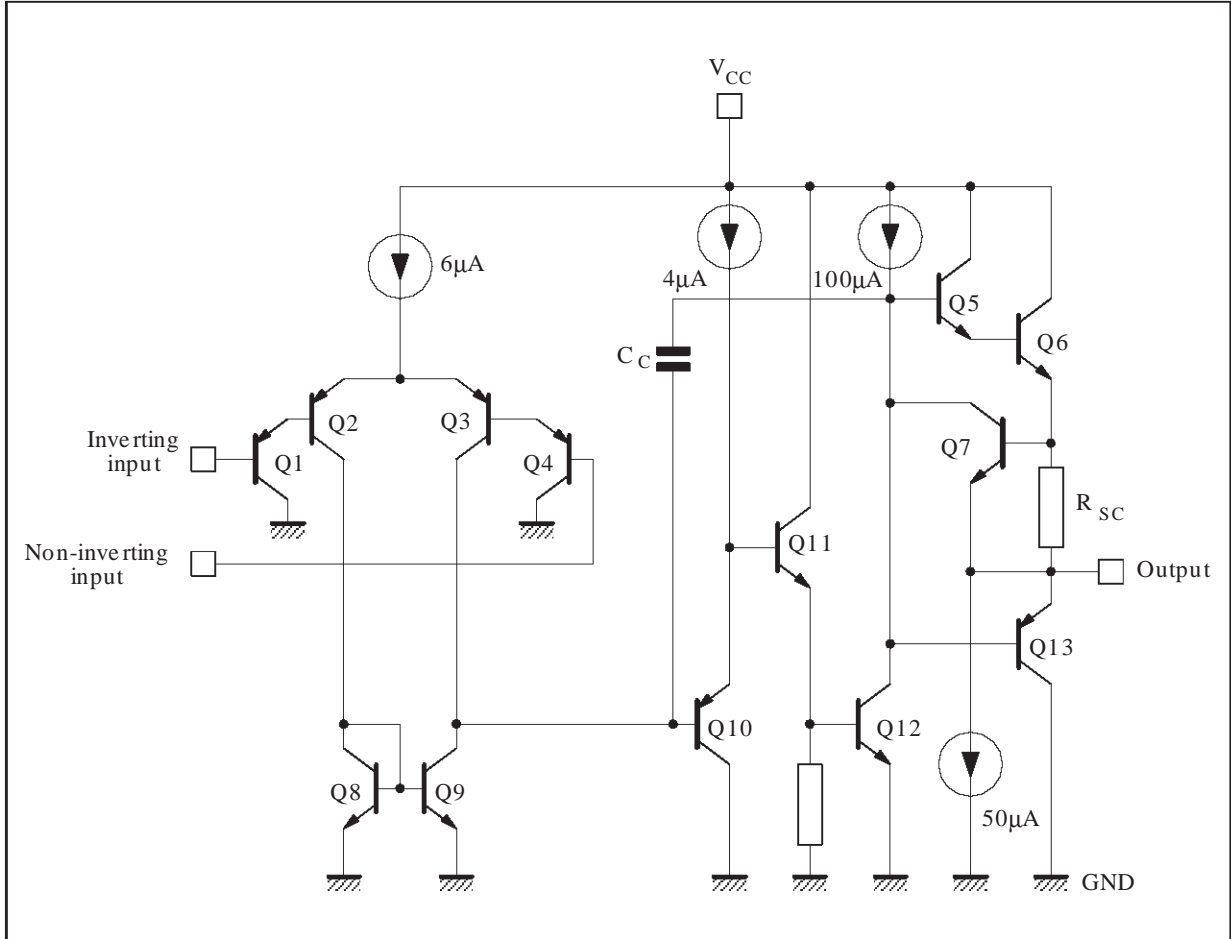

ABSOLUTE MAXIMUM RATINGS

Symbol	Parameter	Value	Unit
V_{cc}	Supply Voltage	± 16 or 32	V
V_i	Input Voltage	-0.3 to +32	V
V_{id}	Differential Input Voltage	+32	V
-	Output Short-circuit Duration - (note 1)	Infinite	
I_{in}	Input Current - (note 5)	50	mA
T_{oper}	Operating Free Air Temperature Range	-40 to +125	$^{\circ}C$
T_{stg}	Storage Temperature Range	-65 to +150	$^{\circ}C$

ELECTRICAL CHARACTERISTICS
 $V_{CC}^+ = +5V$, $V_{CC}^- = \text{Ground}$, $V_O = 1.4V$, $T_{amb} = +25^\circ C$ (unless otherwise specified)

Symbol	Parameter	Min.	Typ.	Max.	Unit
V_{io}	Input Offset Voltage (note 3) $T_{amb} = +25^\circ C$ $T_{min.} \leq T_{amb} \leq T_{max.}$ TS321A TS321A		0.5	4 2 5 3	mV
I_{io}	Input Offset Current $T_{amb} = +25^\circ C$ $T_{min.} \leq T_{amb} \leq T_{max.}$		2	30 50	nA
I_{ib}	Input Bias Current (note 2) $T_{amb} = +25^\circ C$ $T_{min.} \leq T_{amb} \leq T_{max.}$		20	150 200	nA
A_{vd}	Large Signal Voltage Gain ($V_{CC}^+ = +15V$, $R_L = 2k\Omega$, $V_O = 1.4V$ to $11.4V$) $T_{amb} = +25^\circ C$ $T_{min.} \leq T_{amb} \leq T_{max.}$	50 25	100		V/mV
SVR	Supply Voltage Rejection Ratio ($R_S \leq 10k\Omega$) ($V_{CC}^+ = 5V$ to $30V$) $T_{amb} = +25^\circ C$	65	110		dB
I_{CC}	Supply Current, no load $T_{amb} = +25^\circ C$ $T_{min.} \leq T_{amb} \leq T_{max.}$ $V_{CC} = +5V$ $V_{CC} = +30V$ $V_{CC} = +5V$ $V_{CC} = +30V$		300 400 350	600 800 800 1000	μA
V_{icm}	Input Common Mode Voltage Range ($V_{CC} = +30V$) - (note 4) $T_{amb} = +25^\circ C$ $T_{min.} \leq T_{amb} \leq T_{max.}$	0 0		$V_{CC} - 1.5$ $V_{CC} - 2$	V
CMR	Common-mode Rejection Ratio ($R_S \leq 10k\Omega$) $T_{amb} = +25^\circ C$	65	85		dB
I_{source}	Output Current Source ($V_{id} = +1V$) $V_{CC} = +15V$, $V_O = +2V$	20	40		mA
I_{sink}	Output Sink Current ($V_{id} = -1V$) $V_{CC} = +15V$, $V_O = +2V$ $V_{CC} = +15V$, $V_O = +0.2V$	10 12	20 50		mA μA
I_o	Short Circuit to Ground $V_{CC} = +15V$		40	60	mA

ELECTRICAL CHARACTERISTICS

$V_{CC}^+ = +5V$, $V_{CC}^- = \text{Ground}$, $V_o = 1.4V$, $T_{amb} = +25^\circ C$ (unless otherwise specified)

Symbol	Parameter	Min.	Typ.	Max.	Unit
V_{OH}	High Level Output Voltage ($V_{CC} = +30V$)				V
	$T_{amb} = +25^\circ C$ $R_L = 2k\Omega$	26	27		
	$T_{min.} \leq T_{amb} \leq T_{max.}$	25.5			
	$T_{amb} = +25^\circ C$ $R_L = 10k\Omega$	27	28		
$T_{min.} \leq T_{amb} \leq T_{max.}$ ($V_{CC} = +5V, R_L = 2k\Omega$)	26.5				
	$T_{amb} = +25^\circ C$	3.5			
	$T_{min.} \leq T_{amb} \leq T_{max.}$	3			
V_{OL}	Low Level Output Voltage ($R_L = 10k\Omega$) $T_{amb} = +25^\circ C$ $T_{min.} \leq T_{amb} \leq T_{max.}$		5	15 20	mV
SR	Slew Rate $V_{CC} = 15V, V_I = 0.5$ to $3V, R_L = 2k\Omega,$ $C_L = 100pF, T_{amb} = +25^\circ C, \text{unity gain}$		0.4		V/ μs
GBP	Gain Bandwidth Product $V_{CC} = 30V, f = 100kHz,$ $T_{amb} = +25^\circ C, V_{in} = 10mV, R_L = 2k\Omega, C_L = 100pF$		0.8		MHz
ϕ_m	Phase Margin		60		Degrees
THD	Total Harmonic Distortion $f = 1kHz, A_V = 20dB, R_L = 2k\Omega,$ $V_o = 2V_{pp}, C_L = 100pF, T_{amb} = +25^\circ C, V_{CC} = 30V$		0.015		%
e_n	Equivalent Input Noise Voltage $f = 1kHz, R_s = 100\Omega, V_{CC} = 30V$		40		$\frac{nV}{\sqrt{Hz}}$

- Notes :**
1. Short-circuits from the output to V_{CC} can cause excessive heating if $V_{CC} > 15V$. The maximum output current is approximately 40mA independent of the magnitude of V_{CC} .
 2. The direction of the input current is out of the IC. This current is essentially constant, independent of the state of the output so no loading change exists on the input lines.
 3. $V_o = 1.4V, R_s = 0\Omega, 5V < V_{CC}^+ < 30V, 0 < V_{ic} < V_{CC}^+ - 1.5V$.
 4. The input common-mode voltage of either input signal voltage should not be allowed to go negative by more than 0.3V. The upper end of the common-mode voltage range is $V_{CC}^+ - 1.5V$, but either or both inputs can go to +32V without damage.
 5. This input current only exists when the voltage at any of the input leads is driven negative. It is due to the collector-base junction of the input PNP transistor becoming forward biased and thereby acting as input diodes clamps. In addition to this diode action, there is also NPN parasitic action on the IC chip. this transistor action can cause the output voltages of the Op-amps to go to the V_{CC} voltage level (or to ground for a large overdrive) for the time duration than an input is driven negative. This is not destructive and normal output will set up again for input voltage higher than -0.3V.

TYPICAL SINGLE - SUPPLY APPLICATIONS

AC COUPLED INVERTING AMPLIFIER

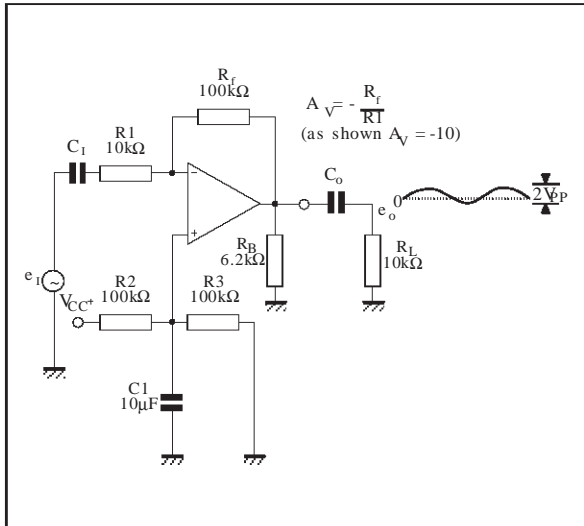

AC COUPLED NON-INVERTING AMPLIFIER

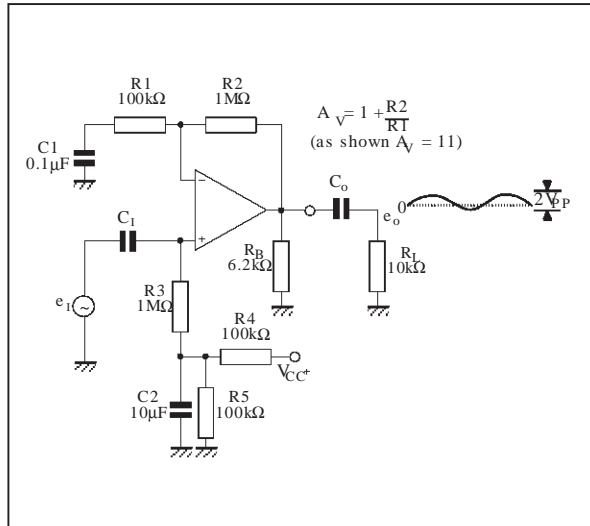

NON-INVERTING DC GAIN

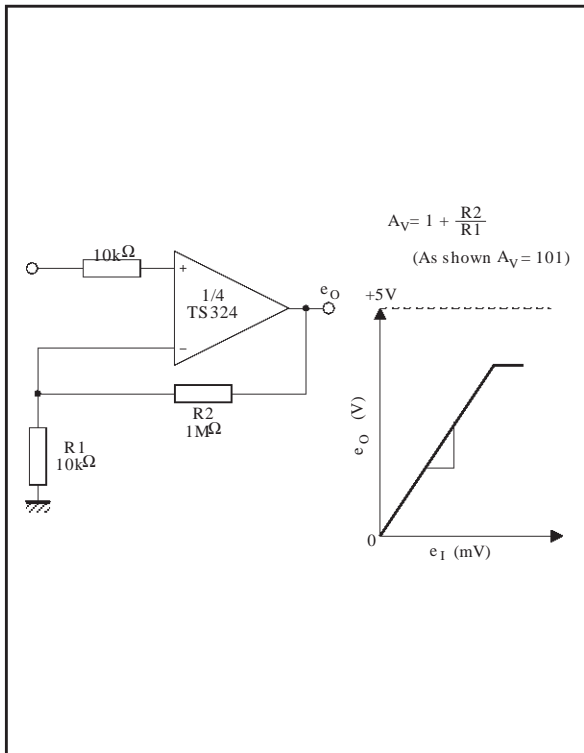

DC SUMMING AMPLIFIER

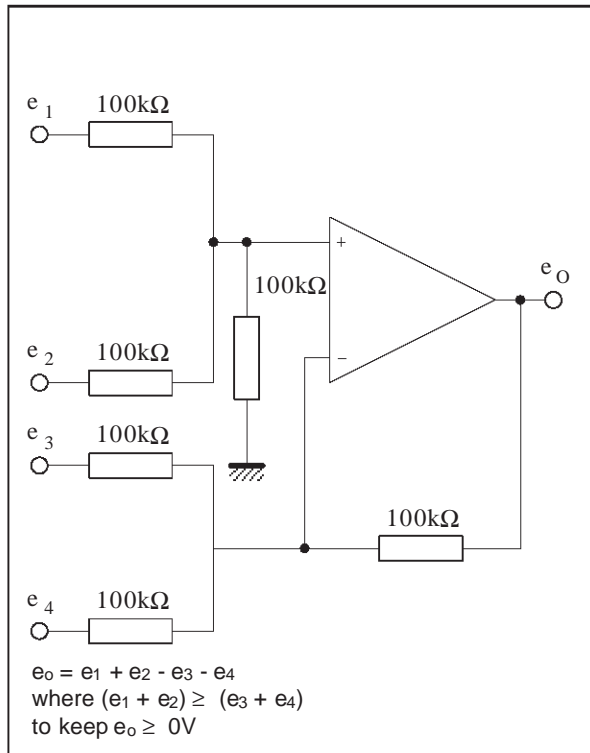

TS321

MACROMODEL

** Standard Linear Ics Macromodels, 1998.

** CONNECTIONS :

* 1 INVERTING INPUT

* 2 NON-INVERTING INPUT

* 3 OUTPUT

* 4 POSITIVE POWER SUPPLY

* 5 NEGATIVE POWER SUPPLY

.SUBCKT TS321 1 3 2 4 5 (analog)

.MODEL MDTH D IS=1E-8 KF=3.104131E-15 CJO=10F

* INPUT STAGE

CIP 2 5 1.000000E-12

CIN 1 5 1.000000E-12

EIP 10 5 2 5 1

EIN 16 5 1 5 1

RIP 10 11 2.600000E+01

RIN 15 16 2.600000E+01

RIS 11 15 2.003862E+02

DIP 11 12 MDTH 400E-12

DIN 15 14 MDTH 400E-12

VOFP 12 13 DC 0

VOFN 13 14 DC 0

IPOL 13 5 1.000000E-05

CPS 11 15 3.783376E-09

DINN 17 13 MDTH 400E-12

VIN 17 5 0.000000E+00

DINR 15 18 MDTH 400E-12

VIP 4 18 2.000000E+00

FCP 4 5 VOFP 3.400000E+01

FCN 5 4 VOFN 3.400000E+01

FIBP 2 5 VOFN 2.000000E-03

FIBN 5 1 VOFP 2.000000E-03

* AMPLIFYING STAGE

FIP 5 19 VOFP 3.600000E+02

FIN 5 19 VOFN 3.600000E+02

RG1 19 5 3.652997E+06

RG2 19 4 3.652997E+06

CC 19 5 6.000000E-09

DOPM 19 22 MDTH 400E-12

DONM 21 19 MDTH 400E-12

HOPM 22 28 VOUT 7.500000E+03

VIPM 28 4 1.500000E+02

HONM 21 27 VOUT 7.500000E+03

VINM 5 27 1.500000E+02

EOUT 26 23 19 5 1

VOUT 23 5 0

ROUT 26 3 20

COUT 3 5 1.000000E-12

DOP 19 25 MDTH 400E-12

VOP 4 25 2.242230E+00

DON 24 19 MDTH 400E-12

VON 24 5 7.922301E-01

.ENDS

ELECTRICAL CHARACTERISTICS

$V_{CC}^+ = +5V$, $V_{CC}^- = 0V$, $T_{amb} = 25^\circ C$ (unless otherwise specified)

Symbol	Conditions	Value	Unit
V_{io}		0	mV
A_{vd}	$R_L = 2k\Omega$	100	V/mV
I_{CC}	No load, per operator	300	μA
V_{icm}		0 to +3.5	V
V_{OH}	$R_L = 2k\Omega$	+3.5	V
V_{OL}	$R_L = 2k\Omega$	5	mV
I_{OS}	$V_O = 0V$	40	mA
GBP	$R_L = 2k\Omega$, $C_L = 100pF$	0.8	MHz
SR	$R_L = 2k\Omega$, $C_L = 100pF$	0.4	V/ μs
$\varnothing m$	$R_L = 2k\Omega$, $C_L = 100pF$	60	Degrees

PACKAGE MECHANICAL DATA
8 PINS - PLASTIC MICROPACKAGE (SO)

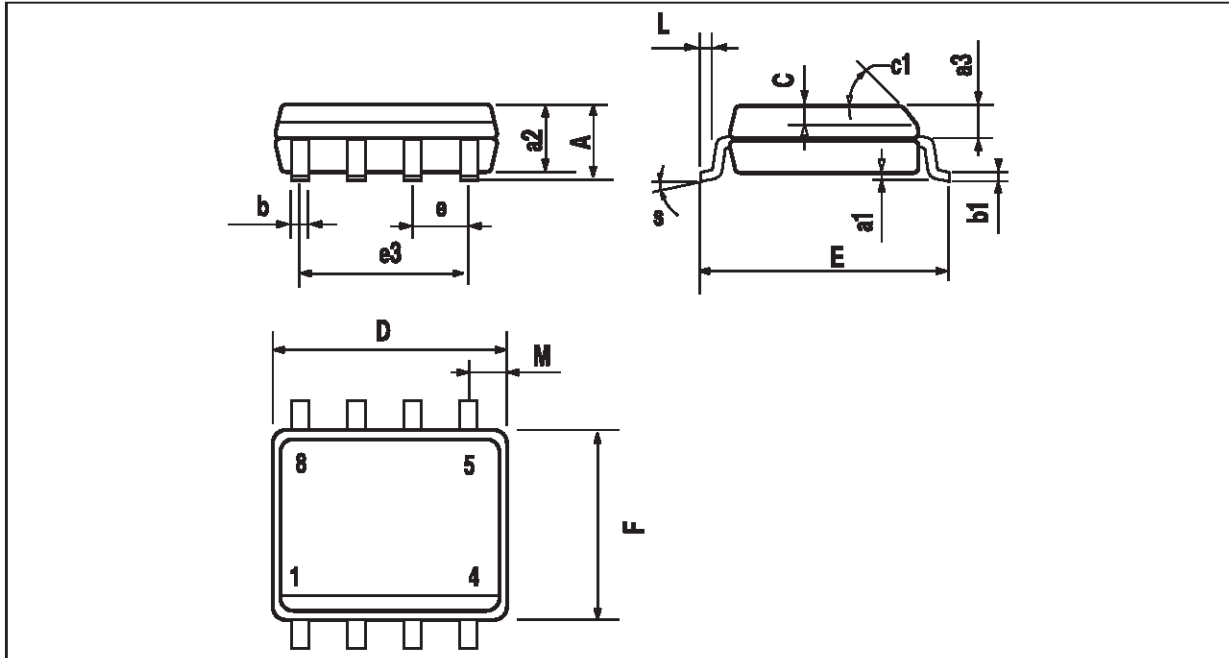

Dim.	Millimeters			Inches		
	Min.	Typ.	Max.	Min.	Typ.	Max.
A			1.75			0.069
a1	0.1		0.25	0.004		0.010
a2			1.65			0.065
a3	0.65		0.85	0.026		0.033
b	0.35		0.48	0.014		0.019
b1	0.19		0.25	0.007		0.010
C	0.25		0.5	0.010		0.020
c1	45° (typ.)					
D	4.8		5.0	0.189		0.197
E	5.8		6.2	0.228		0.244
e		1.27			0.050	
e3		3.81			0.150	
F	3.8		4.0	0.150		0.157
L	0.4		1.27	0.016		0.050
M			0.6			0.024
S	8° (max.)					

TS321

PACKAGE MECHANICAL DATA 5 PINS - TINY PACKAGE (SOT23)

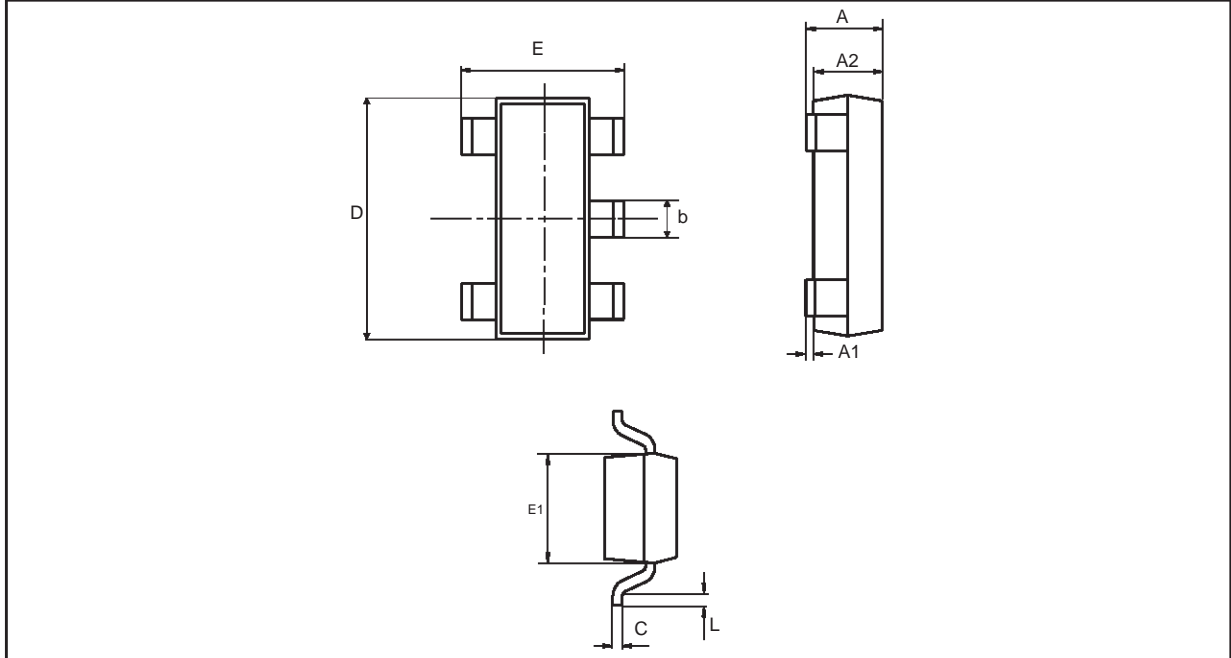

Dim.	Millimeters		Inches	
	Min.	Max.	Min.	Max.
A	0.90	1.45	0.034	0.057
A1	0	0.15		0.006
A2	0.90	1.30	0.034	0.051
b	0.35	0.50	0.013	0.020
C	0.09	0.20	0.003	0.008
D	2.80	3.00	0.110	0.118
E	2.60	3.00	0.102	0.118
E1	1.50	1.75	0.059	0.069
L	0.10	0.60	0.003	0.024

Information furnished is believed to be accurate and reliable. However, STMicroelectronics assumes no responsibility for the consequences of use of such information nor for any infringement of patents or other rights of third parties which may result from its use. No license is granted by implication or otherwise under any patent or patent rights of STMicroelectronics. Specifications mentioned in this publication are subject to change without notice. This publication supersedes and replaces all information previously supplied. STMicroelectronics products are not authorized for use as critical components in life support devices or systems without express written approval of STMicroelectronics.

© The ST logo is a trademark of STMicroelectronics

© 1998 STMicroelectronics – Printed in Italy – All Rights Reserved

STMicroelectronics GROUP OF COMPANIES

Australia - Brazil - Canada - China - France - Germany - Italy - Japan - Korea - Malaysia - Malta - Mexico - Morocco
The Netherlands - Singapore - Spain - Sweden - Switzerland - Taiwan - Thailand - United Kingdom - U.S.A.

© <http://www.st.com>