

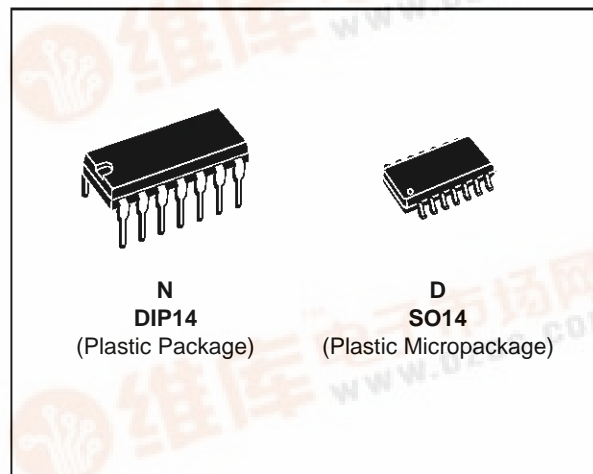

TS556C,I,M

LOW POWER DUAL CMOS TIMERS

- VERY LOW POWER CONSUMPTION :
 - 100µA typ at V_{CC} = 5V
- HIGH MAXIMUM ASTABLE FREQUENCY 2.7MHz
- PIN-TO-PIN AND FUNCTIONALLY COMPATIBLE WITH BIPOLAR NE555
- VOLTAGE RANGE : +2V to +18V
- HIGH OUTPUT CURRENT CAPABILITY
- SUPPLY CURRENT SPIKES REDUCED DURING OUTPUT TRANSITIONS
- HIGH INPUT IMPEDANCE : 10¹² Ω
- OUTPUT COMPATIBLE WITH TTL,CMOS AND LOGIC MOS



ORDER CODES

Part Number	Temperature Range	Package	
		N	D
TS556C	0°C, +70°C	●	●
TS556I	-40, +125°C	●	●
TS556M	-55, +125°C	●	●

Examples : TS556CD , TS556IN

DESCRIPTION

The TS556 is a dual CMOS timer which offers very low consumption (I_{CC(TYP)} TS556 = 200µA I_{CC(TYP)} NE556 = 6mA) and high frequency (f_(max.) TS556 = 2.7MHz - f_(max.) NE556 = 0.1 MHz) Thus, either in Monostable or Astable mode, timing remains very accurate.

The TS556 provides reduced supply current spikes during output transitions, which enables the use of lower decoupling capacitors compared to those required by bipolar NE556.

Timing capacitors can also be minimized due to high input impedance (10¹² Ω).

PIN CONNECTIONS (top view)

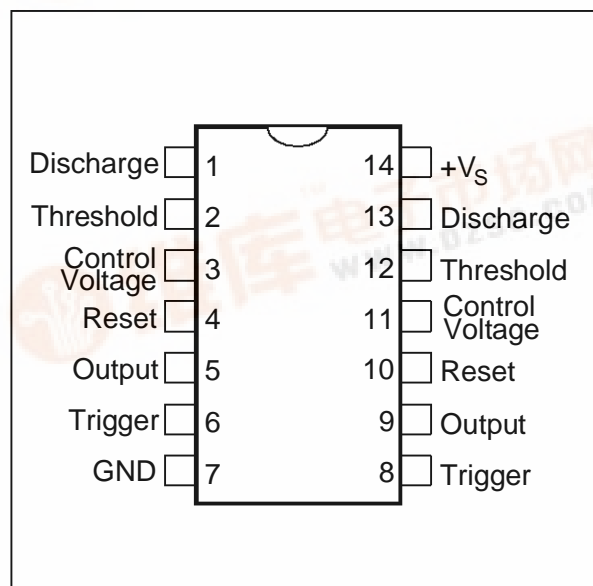

TS556C,I,M

BLOCK DIAGRAM

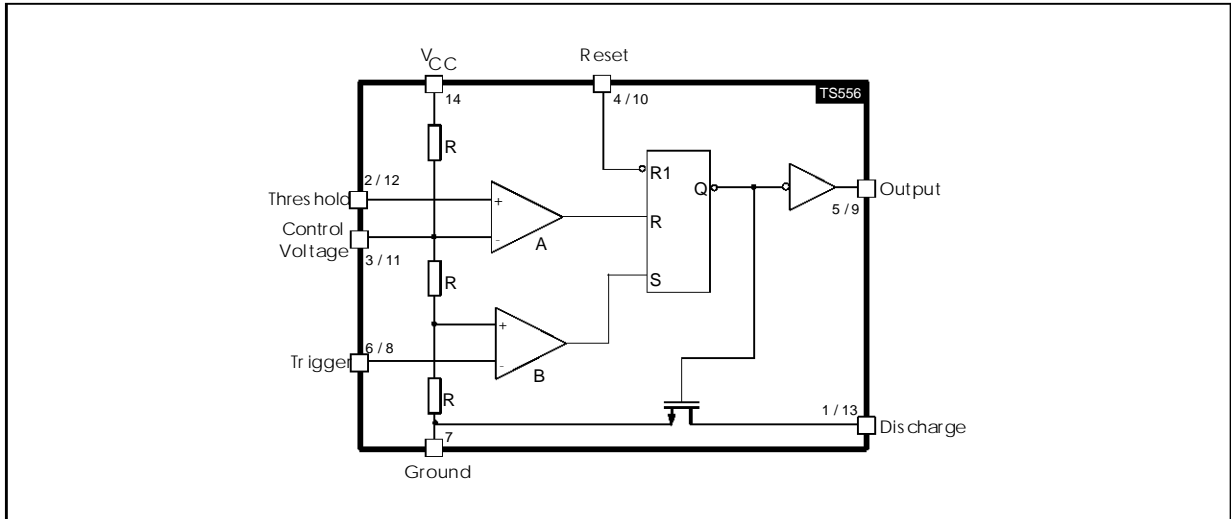

RESET	TRIGGER	THRESHOLD	OUTPUT
Low	x	x	Low
High	Low	x	High
High	High	High	Low
High	High	Low	Previous State

- LOW** ↔ Level Voltage \leq Min voltage specified
HIGH ↔ Level Voltage \geq Max voltage specified
X ↔ Irrelevant

ABSOLUTE MAXIMUM RATINGS

Symbol	Parameter	Value	Unit
V _{CC}	Supply Voltage	+18	V
T _J	Junction Temperature	+150	°C

THERMAL CHARACTERISTICS

Symbol	Parameter	Value	Unit
T _{OPER}	Operating Temperature Range TS556C TS556I TS556M	0 to +70 -40 to +125 -55 to +125	°C
T _{STG}	Storage Temperature Range	-65 to +150	°C

SCHEMATIC DIAGRAM (1/2 TS556)

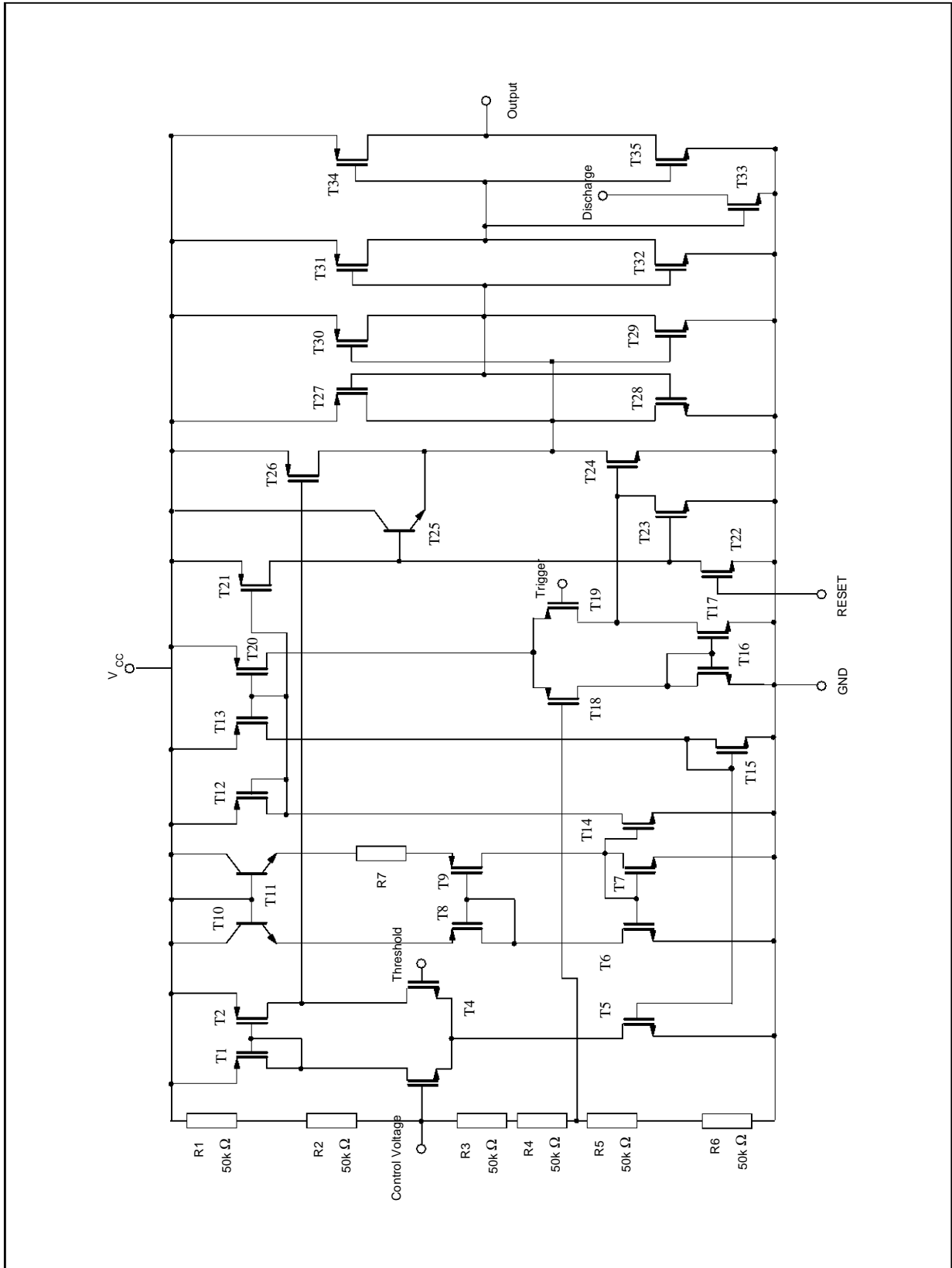

TS556C,I,M

OPERATING CONDITIONS

Symbol	Parameter	Value	Unit
V _{CC}	Supply Voltage	+2 to +16	V

STATIC ELECTRICAL CHARACTERISTICS

V_{CC} = +2V, T_{amb} = +25°C, Reset to V_{CC} (unless otherwise specified)

Symbol	Parameter	TS556C-TS556I-TS556M			Unit
		Min.	Typ	Max.	
I _{CC}	Supply Current (no load, High and Low States) T _{amb} = +25°C T _{min.} ≤ T _{amb} ≤ T _{max.}		130	400 400	μA
V _{CL}	Control Voltage T _{amb} = +25°C T _{min.} ≤ T _{amb} ≤ T _{max.}	1.2 1.1	1.3	1.4 1.5	V
V _{dis}	Discharge Saturation Voltage (I _{dis} = 1mA) T _{amb} = +25°C T _{min.} ≤ T _{amb} ≤ T _{max.}		0.05	0.2 0.25	V
V _{OL}	Low Level Output Voltage (I _{sink} = 1mA) T _{amb} = +25°C T _{min.} ≤ T _{amb} ≤ T _{max.}		0.1	0.3 0.35	V
V _{OH}	High Level Output Voltage (I _{source} = -0.3mA) T _{amb} = +25°C T _{min.} ≤ T _{amb} ≤ T _{max.}	1.5 1.5	1.9		V
V _{trig}	Trigger Voltage T _{amb} = +25°C T _{min.} ≤ T _{amb} ≤ T _{max.}	0.4 0.3	0.67	0.95 1.05	V
I _{trig}	Trigger Current		10		pA
I _{TH}	Threshold Current		10		pA
V _{reset}	Reset Voltage T _{amb} = +25°C T _{min.} ≤ T _{amb} ≤ T _{max.}	0.4 0.3	1.1	1.5 2.0	V
I _{reset}	Reset Current		10		pA
I _{dis}	Discharge Pin Leakage Current		1	100	nA

STATIC ELECTRICAL CHARACTERISTICS (continued)V_{CC} = +5V, T_{amb} = +25°C, Reset to V_{CC} (unless otherwise specified)

Symbol	Parameter	TS556C-TS556I-TS556M			Unit
		Min.	Typ	Max.	
I _{CC}	Supply Current (no load, High and Low States) T _{amb} = +25°C T _{min.} ≤ T _{amb} ≤ T _{max.}		220	500 500	μA
V _{CL}	Control Voltage T _{amb} = +25°C T _{min.} ≤ T _{amb} ≤ T _{max.}	2.9 2.8	3.3	3.8 3.9	V
V _{dis}	Discharge Saturation Voltage (I _{dis} = 10mA) T _{amb} = +25°C T _{min.} ≤ T _{amb} ≤ T _{max.}		0.2	0.3 0.35	V
V _{OL}	Low Level Output Voltage (I _{sink} = 8mA) T _{amb} = +25°C T _{min.} ≤ T _{amb} ≤ T _{max.}		0.3	0.6 0.8	V
V _{OH}	High Level Output Voltage (I _{source} = -2mA) T _{amb} = +25°C T _{min.} ≤ T _{amb} ≤ T _{max.}	4.4 4.4	4.6		V
V _{trig}	Trigger Voltage T _{amb} = +25°C T _{min.} ≤ T _{amb} ≤ T _{max.}	1.36 1.26	1.67	1.96 2.06	V
I _{trig}	Trigger Current		10		pA
I _{TH}	Threshold Current		10		pA
V _{reset}	Reset Voltage T _{amb} = +25°C T _{min.} ≤ T _{amb} ≤ T _{max.}	0.4 0.3	1.1	1.5 2.0	V
I _{reset}	Reset Current		10		pA
I _{dis}	Discharge Pin Leakage Current		1	100	nA

TS556C,I,M

STATIC ELECTRICAL CHARACTERISTICS (continued)

V_{CC} = +12V, T_{amb} = +25°C, Reset to V_{CC} (unless otherwise specified)

Symbol	Parameter	TS556C-TS556I-TS556M			Unit
		Min.	Typ	Max.	
I _{CC}	Supply Current (no load, High and Low States) T _{amb} = +25°C T _{min.} ≤ T _{amb} ≤ T _{max.}		340	800 800	μA
V _{CL}	Control Voltage T _{amb} = +25°C T _{min.} ≤ T _{amb} ≤ T _{max.}	7.4 7.3	8	8.6 8.7	V
V _{dis}	Discharge Saturation Voltage (I _{dis} = 80mA) T _{amb} = +25°C T _{min.} ≤ T _{amb} ≤ T _{max.}		0.09	1.6 2.0	V
V _{OL}	Low Level Output Voltage (I _{sink} = 50mA) T _{amb} = +25°C T _{min.} ≤ T _{amb} ≤ T _{max.}		1.2	2 2.8	V
V _{OH}	High Level Output Voltage (I _{source} = -10mA) T _{amb} = +25°C T _{min.} ≤ T _{amb} ≤ T _{max.}	10.5 10.5	11		V
V _{trig}	Trigger Voltage T _{amb} = +25°C T _{min.} ≤ T _{amb} ≤ T _{max.}	3.2 3.1	4	4.8 4.9	V
I _{trig}	Trigger Current		10		pA
I _{TH}	Threshold Current		10		pA
V _{reset}	Reset Voltage T _{amb} = +25°C T _{min.} ≤ T _{amb} ≤ T _{max.}	0.4 0.3	1.1	1.5 2.0	V
I _{reset}	Reset Current		10		pA
I _{dis}	Discharge Pin Leakage Current		1	100	nA

DYNAMIC ELECTRICAL CHARACTERISTICST_{amb} = +25°C, Reset to V_{CC} (unless otherwise specified)

Symbol	Parameter	TS556C-TS556I-TS556M			Unit
		Min	Typ	Max	
	Timing Accuracy (Monostable) - (note 1) R = 10kΩ, C = 0.1μF V _{CC} = +2V V _{CC} = +5V V _{CC} = +12V		1 2 4		%
	Timing Shift with supply voltage variations (Monostable) R = 10kΩ, C = 0.1μF, V _{CC} = +5V +/-1V		0.38		%/V
	Timing Shift with temperature T _{min.} ≤ T _{amb} ≤ T _{max.} , V _{CC} = +5V		75		ppm/°C
f _{max}	Maximum astable frequency R _A = 470Ω, R _B = 200Ω, C = 200pF, V _{CC} = +5V		2.7		MHz
	Astable frequency accuracy - (note 2) R _A = R _B = 1kΩ to 100kΩ, C = 0.1μF V _{CC} = +5V V _{CC} = +12V		3 3		%
	Timing Shift with supply voltage variations (Astable mode) R _A = R _B = 1kΩ to 100kΩ, C = 0.1μF, V _{CC} = 5 to+ 12V		0.1		%/V
t _r	Output Rise Time (V _{CC} = +5V, C _{load} = 10pF)		25		ns
t _f	Output Fall Time (V _{CC} = +5V, C _{load} = 10pF)		20	-	ns
t _{pd}	Trigger Propagation Delay (V _{CC} = +5V)		100		ns
t _{rpw}	Minimum Reset Pulse Width (V _{trig} = +5V)		350		ns

Notes : 1. See Figure 2
2. See Figure 4

TYPICAL CHARACTERISTICS

Figure 1 : Supply Current (each timer) versus Supply Voltage

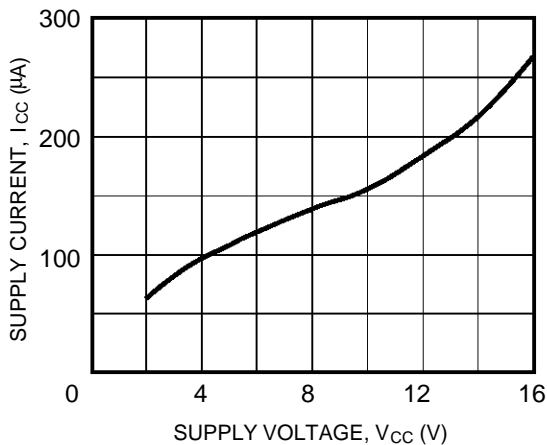

APPLICATION INFORMATION

MONOSTABLE OPERATION

In the monostable mode, the timer functions as a one-shot. Referring to figure 2 the external capacitor is initially held discharged by a transistor inside the timer.

Figure 2

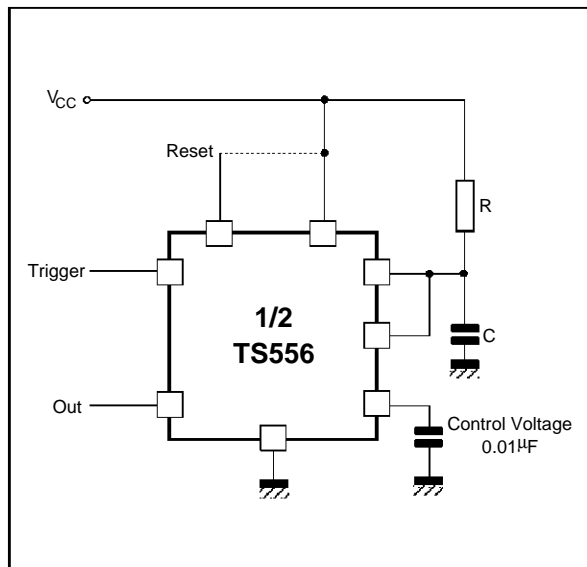

The circuit triggers on a negative-going input signal when the level reaches $1/3 V_{CC}$. Once triggered, the circuit remains in this state until the set time has elapsed, even if it is triggered again during this interval. The duration of the output HIGH state is given by $t = 1.1 R \times C$.

Notice that since the charge rate and the threshold level of the comparator are both directly proportional to supply voltage, the timing interval is independent of supply. Applying a negative pulse simultaneously to the Reset terminal (pin 4 or 10) and the Trigger terminal (pin 2 or 8) during the timing cycle discharges the external capacitor and causes the cycle to start over. The timing cycle now starts on the positive edge of the reset pulse. During the time the reset pulse is applied, the output is driven to its LOW state.

When a negative trigger pulse is applied to the trigger terminal, the flip-flop is set, releasing the short circuit across the external capacitor and driving the output HIGH. The voltage across the capacitor increases exponentially with the time constant $\tau = R \times C$.

When the voltage across the capacitor equals $2/3 V_{CC}$, the comparator resets the flip-flop which then discharges the capacitor rapidly and drives the output to its LOW state.

Figure 3 shows the actual waveforms generated in this mode of operation.

When Reset is not used, it should be tied high to avoid any possible or false triggering.

Figure 3

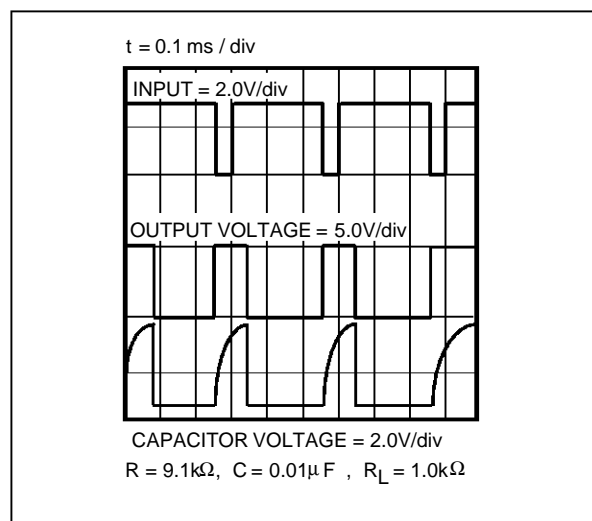

ASTABLE OPERATION

When the circuit is connected as shown in figure 4 it triggers itself and free runs as a multivibrator. The external capacitor charges through R_A and R_B and discharges through R_B only. Thus the duty cycle may be precisely set by the ratio of these two resistors.

In the astable mode of operation, C charges and discharges between $1/3 V_{CC}$ and $2/3 V_{CC}$. As in the triggered mode, the charge and discharge times and therefore frequency, are independent of the supply voltage.

Figure 5 shows actual waveforms generated in this

mode of operation.

The charge time (output HIGH) is given by :

$$t_1 = 0.693 (R_A + R_B) C$$

and the discharge time (output LOW) by :

$$t_2 = 0.693 (R_B) C$$

Thus the total period T is given by :

$$T = t_1 + t_2 = 0.693 (R_A + 2R_B) C$$

The frequency of oscillation is then :

$$f = \frac{1}{T} = \frac{1.44}{(R_A + 2R_B)C}$$

The duty cycle is given by : $D = \frac{R_B}{R_A + 2R_B}$

Figure 4

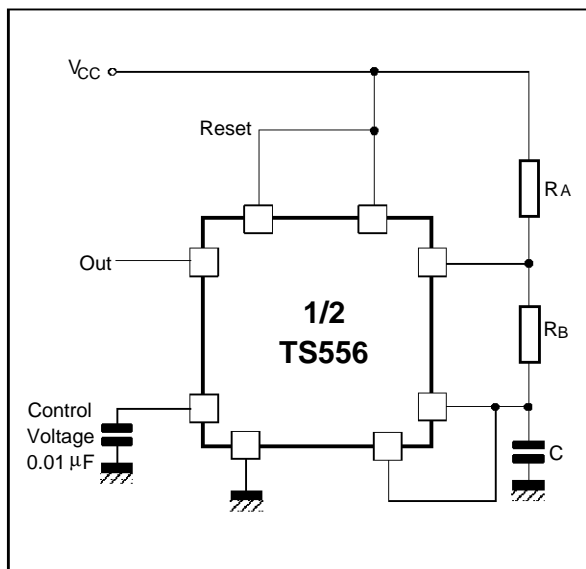
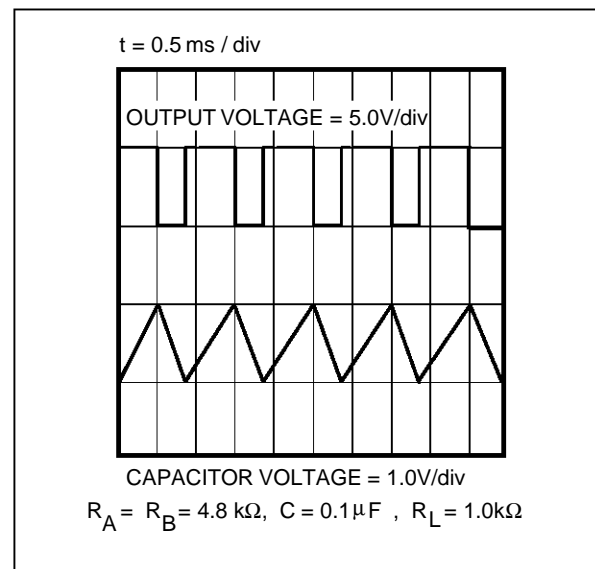

Figure 5



TS556C,I,M

PACKAGE MECHANICAL DATA

14 PINS - PLASTIC DIP

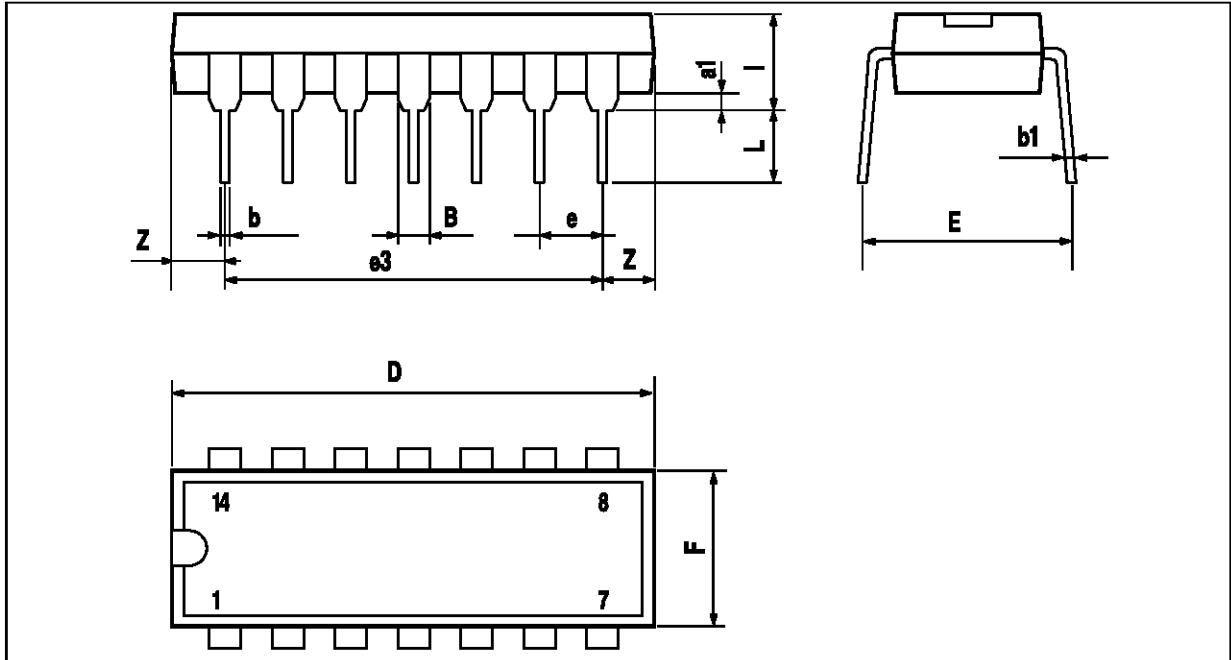

PW-DIP14.EPS

Dimensions	Millimeters			Inches		
	Min.	Typ.	Max.	Min.	Typ.	Max.
a1	0.51			0.020		
B	1.39		1.65	0.055		0.065
b		0.5			0.020	
b1		0.25			0.010	
D			20			0.787
E		8.5			0.335	
e		2.54			0.100	
e3		15.24			0.600	
F			7.1			0.280
i			5.1			0.201
L		3.3			0.130	
Z	1.27		2.54	0.050		0.100

DIP14.TBL

PACKAGE MECHANICAL DATA
14 PINS - PLASTIC MICROPACKAGE (SO)

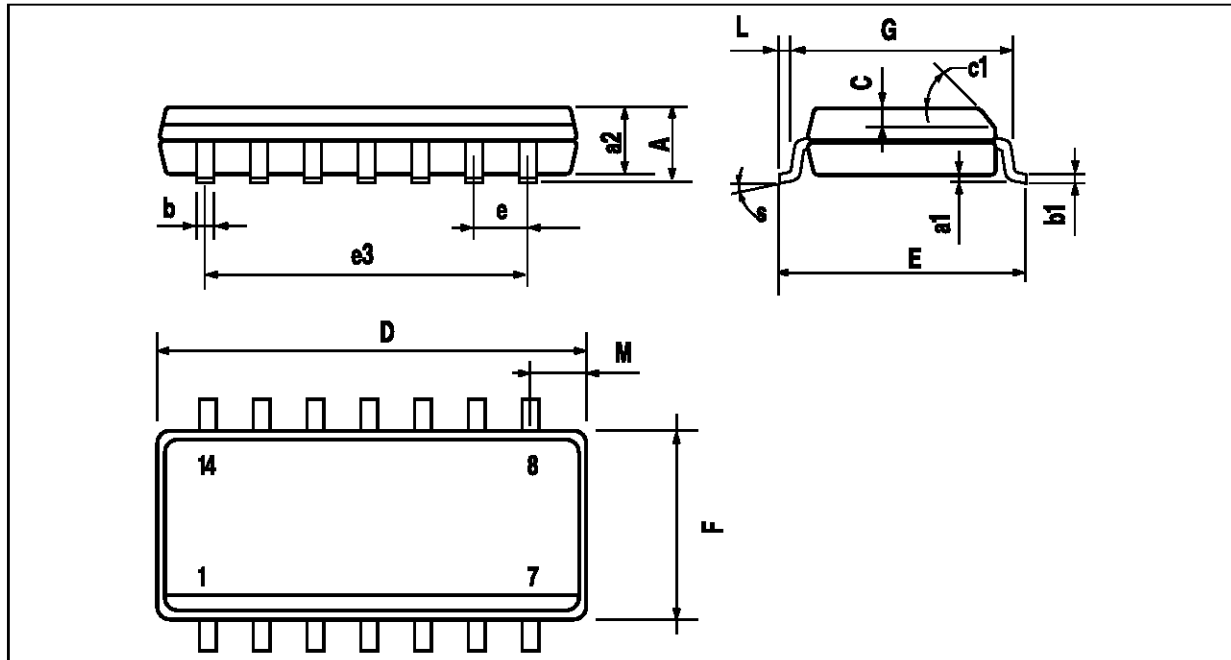

PM-SO14.EPS

Dimensions	Millimeters			Inches		
	Min.	Typ.	Max.	Min.	Typ.	Max.
A			1.75			0.069
a1	0.1		0.2	0.004		0.008
a2			1.6			0.063
b	0.35		0.46	0.014		0.018
b1	0.19		0.25	0.007		0.010
C		0.5			0.020	
c1	45° (typ.)					
D	8.55		8.75	0.336		0.334
E	5.8		6.2	0.228		0.244
e		1.27			0.050	
e3		7.62			0.300	
F	3.8		4.0	0.150		0.157
G	4.6		5.3	0.181		0.208
L	0.5		1.27	0.020		0.050
M			0.68			0.027
S	8° (max.)					

SO14.TBL

Information furnished is believed to be accurate and reliable. However, SGS-THOMSON Microelectronics assumes no responsibility for the consequences of use of such information nor for any infringement of patents or other rights of third parties which may result from its use. No license is granted by implication or otherwise under any patent or patent rights of SGS-THOMSON Microelectronics. Specification mentioned in this publication are subject to change without notice. This publication supersedes and replaces all information previously supplied. SGS-THOMSON Microelectronics products are not authorized for use as critical components in life support devices or systems without express written approval of SGS-THOMSON Microelectronics.

© 1997 SGS-THOMSON Microelectronics – Printed in Italy – All Rights Reserved

SGS-THOMSON Microelectronics GROUP OF COMPANIES
Australia - Brazil - Canada - China - France - Germany - Hong Kong - Italy - Japan - Korea - Malaysia - Malta - Morocco
The Netherlands - Singapore - Spain - Sweden - Switzerland - Taiwan - Thailand - United Kingdom - U.S.A.

ORDER CODE: