

FEATURES

- Isolation in Powered-Down Mode, $V_{+} = 0$
- Low ON-State Resistance (0.9 Ω)
- Control Inputs Are 5.5-V Tolerant
- Low Charge Injection
- Excellent ON-State Resistance Matching
- Low Total Harmonic Distortion (THD)
- 1.65-V to 5.5-V Single-Supply Operation
- Latch-Up Performance Exceeds 100 mA Per JESD 78, Class II
- ESD Performance Tested Per JESD 22
 - 2000-V Human-Body Model (A114-B, Class II)
 - 1000-V Charged-Device Model (C101)

APPLICATIONS

- Cell Phones
- PDAs
- Portable Instrumentation
- Audio and Video Signal Routing
- Low-Voltage Data-Acquisition Systems
- Communication Circuits
- Modems
- Hard Drives
- Computer Peripherals
- Wireless Terminals and Peripherals

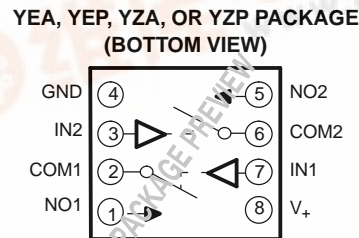
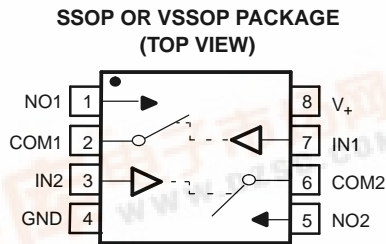

DESCRIPTION/ORDERING INFORMATION

The TS5A23166 is a dual single-pole single-throw (SPST) analog switch that is designed to operate from 1.65 V to 5.5 V. The device offers a low ON-state resistance and an excellent channel-to-channel ON-state resistance matching. The device has excellent total harmonic distortion (THD) performance and consumes very low power. These features make this device suitable for portable audio applications.

ORDERING INFORMATION

T_A	PACKAGE ⁽¹⁾		ORDERABLE PART NUMBER	TOP-SIDE MARKING ⁽²⁾
–40°C to 85°C	NanoStar™ – WCSP (DSBGA) 0.23-mm Large Bump – YEP	Tape and reel	TS5A23166YEPR	PACKAGE PREVIEW
	NanoFree™ – WCSP (DSBGA) 0.23-mm Large Bump – YZP (Pb-free)		TS5A23166YZPR	PACKAGE PREVIEW
	SSOP – DCT	Tape and reel	TS5A23166DCTR	PACKAGE PREVIEW
	VSSOP – DCU (Pb-free)	Tape and reel	TS5A23166DCUR	JAM_

- (1) Package drawings, standard packing quantities, thermal data, symbolization, and PCB design guidelines are available at www.ti.com/sc/package.
- (2) DCT: The actual top-side marking has three additional characters that designate the year, month, and assembly/test site.
DCU: The actual top-side marking has one additional character that designates the assembly/test site.
YEP/YZP: The actual top-side marking has three preceding characters to denote year, month, and sequence code, and one following character to designate the assembly/test site. Pin 1 identifier indicates solder-bump composition (1 = SnPb, • = Pb-free).

TS5A23166
0.9-Ω DUAL SPST ANALOG SWITCH
5-V/3.3-V 2-CHANNEL ANALOG SWITCH

SCDS196–MAY 2005



SUMMARY OF CHARACTERISTICS⁽¹⁾

Configuration	Dual Single Pole, Single Throw (2 × SPST)
Number of channels	2
ON-state resistance (r_{on})	0.9 Ω
ON-state resistance match (Δr_{on})	0.1 Ω
ON-state resistance flatness ($r_{on(Flat)}$)	0.25 Ω
Turn-on/turn-off time (t_{ON}/t_{OFF})	7.5 ns/9 ns
Charge injection (Q_C)	6 pC
Bandwidth (BW)	150 MHz
OFF isolation (O_{ISO})	–62 dB at 1 MHz
Crosstalk (X_{TALK})	–85 dB at 1 MHz
Total harmonic distortion (THD)	0.005%
Leakage current ($I_{COM(OFF)}$)	±20 nA
Power-supply current (I_+)	0.1 μA
Package option	8-pin VSSOP

(1) $V_+ = 5\text{ V}$, $T_A = 25^\circ\text{C}$

FUNCTION TABLE

IN	NO TO COM, COM TO NO
L	OFF
H	ON

Absolute Maximum Ratings⁽¹⁾⁽²⁾

over operating free-air temperature range (unless otherwise noted)

		MIN	MAX	UNIT
V_+	Supply voltage range ⁽³⁾	–0.5	6.5	V
V_{NO} V_{COM}	Analog voltage range ⁽³⁾⁽⁴⁾⁽⁵⁾	–0.5	$V_+ + 0.5$	V
I_K	Analog port diode current	$V_{NO}, V_{COM} < 0$		mA
I_{NO} I_{COM}	On-state switch current On-state peak switch current ⁽⁶⁾	$V_{NO}, V_{COM} = 0$ to V_+		mA
V_I	Digital input voltage range ⁽³⁾⁽⁴⁾	–0.5	6.5	V
I_{IK}	Digital input clamp current	$V_I < 0$		mA
I_+	Continuous current through V_+		100	mA
I_{GND}	Continuous current through GND	–100	100	mA
θ_{JA}	Package thermal impedance ⁽⁷⁾	DCT package		°C/W
		DCU package		
		YEA/YZA package		
		YEP/YZP package		
T_{stg}	Storage temperature range	–65	150	°C

- (1) Stresses beyond those listed under "absolute maximum ratings" may cause permanent damage to the device. These are stress ratings only, and functional operation of the device at these or any other conditions beyond those indicated under "recommended operating conditions" is not implied. Exposure to absolute-maximum-rated conditions for extended periods may affect device reliability.
- (2) The algebraic convention, whereby the most negative value is a minimum and the most positive value is a maximum
- (3) All voltages are with respect to ground, unless otherwise specified.
- (4) The input and output voltage ratings may be exceeded if the input and output clamp-current ratings are observed.
- (5) This value is limited to 5.5 V maximum.
- (6) Pulse at 1-ms duration < 10% duty cycle.
- (7) The package thermal impedance is calculated in accordance with JESD 51-7.

Electrical Characteristics for 5-V Supply⁽¹⁾

$V_+ = 4.5\text{ V to }5.5\text{ V}$, $T_A = -40^\circ\text{C to }85^\circ\text{C}$ (unless otherwise noted)

PARAMETER	SYMBOL	TEST CONDITIONS	T_A	V_+	MIN	TYP	MAX	UNIT
Analog Switch								
Analog signal range	V_{COM}, V_{NO}				0		V_+	V
Peak ON resistance	r_{peak}	$0 \leq V_{NO} \leq V_+$, $I_{COM} = -100\text{ mA}$,	Switch ON, See Figure 13	25°C Full	4.5 V	0.9	1.1 1.2	Ω
ON-state resistance	r_{on}	$V_{NO} = 2.5\text{ V}$, $I_{COM} = -100\text{ mA}$,	Switch ON, See Figure 13	25°C Full	4.5 V	0.75	0.9 1	Ω
ON-state resistance match between channels	Δr_{on}	$V_{NO} = 2.5\text{ V}$, $I_{COM} = -100\text{ mA}$,	Switch ON, See Figure 13	25°C Full	4.5 V	0.04	0.1 0.1	Ω
ON-state resistance flatness	$r_{on(Flat)}$	$0 \leq V_{NO} \leq V_+$, $I_{COM} = -100\text{ mA}$,	Switch ON, See Figure 13	25°C Full	4.5 V	0.2 0.15	0.25 0.25	Ω
NO OFF leakage current	$I_{NO(OFF)}$	$V_{NO} = 1\text{ V}$, $V_{COM} = 4.5\text{ V}$, or $V_{NO} = 4.5\text{ V}$, $V_{COM} = 1\text{ V}$,	Switch OFF, See Figure 14	25°C Full	5.5 V	0 V -150	4 150	20 nA
	$I_{NO(PWROFF)}$	$V_{NO} = 0\text{ to }5.5\text{ V}$, $V_{COM} = 5.5\text{ V to }0$,	Switch OFF, See Figure 14	25°C Full	0 V	-10 -50	0.2 50	10 μA
COM OFF leakage current	$I_{COM(OFF)}$	$V_{COM} = 1\text{ V}$, $V_{NO} = 4.5\text{ V}$, or $V_{COM} = 4.5\text{ V}$, $V_{NO} = 1\text{ V}$,	Switch OFF, See Figure 14	25°C Full	5.5 V	0 V -150	4 150	20 nA
	$I_{COM(PWROFF)}$	$V_{COM} = 0\text{ to }5.5\text{ V}$, $V_{NO} = 5.5\text{ V to }0$,	Switch OFF, See Figure 14	25°C Full	0 V	-10 -50	0.2 50	10 μA
NO ON leakage current	$I_{NO(ON)}$	$V_{NO} = 1\text{ V}$, $V_{COM} = \text{Open}$, or $V_{NO} = 4.5\text{ V}$, $V_{COM} = \text{Open}$,	Switch ON, See Figure 15	25°C Full	5.5 V	-5 -50	0.4 50	5 nA
COM ON leakage current	$I_{COM(ON)}$	$V_{COM} = 1\text{ V}$, $V_{NO} = \text{Open}$, or $V_{COM} = 4.5\text{ V}$, $V_{NO} = \text{Open}$,	Switch ON, See Figure 15	25°C Full	5.5 V	-5 -50	0.4 50	5 nA
Digital Control Inputs (IN1, IN2)⁽²⁾								
Input logic high	V_{IH}			Full		2.4	5.5	V
Input logic low	V_{IL}			Full		0	0.8	V
Input leakage current	I_{IH}, I_{IL}	$V_I = 5.5\text{ V or }0$		25°C	5.5 V	-2	0.3	2
				Full		-20		20

(1) The algebraic convention, whereby the most negative value is a minimum and the most positive value is a maximum

(2) All unused digital inputs of the device must be held at V_+ or GND to ensure proper device operation. Refer to the TI application report, *Implications of Slow or Floating CMOS Inputs*, literature number SCBA004.

TS5A23166
0.9-Ω DUAL SPST ANALOG SWITCH
5-V/3.3-V 2-CHANNEL ANALOG SWITCH



SCDS196–MAY 2005

Electrical Characteristics for 5-V Supply⁽¹⁾ (continued)

$V_+ = 4.5\text{ V to }5.5\text{ V}$, $T_A = -40^\circ\text{C to }85^\circ\text{C}$ (unless otherwise noted)

PARAMETER	SYMBOL	TEST CONDITIONS	T_A	V_+	MIN	TYP	MAX	UNIT
Dynamic								
Turn-on time	t_{ON}	$V_{COM} = V_+$, $R_L = 50\ \Omega$, $C_L = 35\text{ pF}$, See Figure 17	25°C	5 V	1	4.5	7.5	ns
			Full	4.5 V to 5.5 V	1		9	
Turn-off time	t_{OFF}	$V_{COM} = V_+$, $R_L = 50\ \Omega$, $C_L = 35\text{ pF}$, See Figure 17	25°C	5 V	4.5	8	11	ns
			Full	4.5 V to 5.5 V	3.5		13	
Charge injection	Q_C	$V_{GEN} = 0$, $R_{GEN} = 0$, $C_L = 1\text{ nF}$, See Figure 21	25°C	5 V		6		pC
NO OFF capacitance	$C_{NO(OFF)}$	$V_{NO} = V_+$ or GND, Switch OFF, See Figure 16	25°C	5 V		19		pF
COM OFF capacitance	$C_{COM(OFF)}$	$V_{COM} = V_+$ or GND, Switch OFF, See Figure 16	25°C	5 V		18		pF
NO ON capacitance	$C_{NO(ON)}$	$V_{NO} = V_+$ or GND, Switch ON, See Figure 16	25°C	5 V		35.5		pF
COM ON capacitance	$C_{COM(ON)}$	$V_{COM} = V_+$ or GND, Switch ON, See Figure 16	25°C	5 V		35.5		pF
Digital input capacitance	C_I	$V_I = V_+$ or GND, See Figure 16	25°C	5 V		2		pF
Bandwidth	BW	$R_L = 50\ \Omega$, Switch ON, See Figure 18	25°C	5 V		150		MHz
OFF isolation	O_{ISO}	$R_L = 50\ \Omega$, $f = 1\text{ MHz}$, Switch OFF, See Figure 19	25°C	5 V		-62		dB
Crosstalk	X_{TALK}	$R_L = 50\ \Omega$, $f = 1\text{ MHz}$, Switch ON, See Figure 20	25°C	5 V		-85		dB
Total harmonic distortion	THD	$R_L = 600\ \Omega$, $C_L = 50\text{ pF}$, $f = 20\text{ Hz to }20\text{ kHz}$, See Figure 22	25°C	5 V		0.005		%
Supply								
Positive supply current	I_+	$V_I = V_+$ or GND, Switch ON or OFF	25°C	5.5 V		0.01	0.1	μA
			Full				1	

(1) The algebraic convention, whereby the most negative value is a minimum and the most positive value is a maximum

Electrical Characteristics for 3.3-V Supply⁽¹⁾
 $V_+ = 4.5 \text{ V to } 5.5 \text{ V}$, $T_A = -40^\circ\text{C to } 85^\circ\text{C}$ (unless otherwise noted)

PARAMETER	SYMBOL	TEST CONDITIONS	T_A	V_+	MIN	TYP	MAX	UNIT	
Analog Switch									
Analog signal range	V_{COM}, V_{NO}				0		V_+	V	
Peak ON resistance	r_{peak}	$0 \leq V_{NO} \leq V_+$, $I_{COM} = -100 \text{ mA}$,	Switch ON, See Figure 13	25°C	3 V	1.3	1.6	Ω	
				Full		1.8			
ON-state resistance	r_{on}	$V_{NO} = 2 \text{ V}$, $I_{COM} = -100 \text{ mA}$,	Switch ON, See Figure 13	25°C	3 V	1.1	1.5	Ω	
				Full		1.7			
ON-state resistance match between channels	Δr_{on}	$V_{NO} = 2 \text{ V}, 0.8 \text{ V}$, $I_{COM} = -100 \text{ mA}$,	Switch ON, See Figure 13	25°C	3 V	0.04	0.1	Ω	
				Full		0.1			
ON-state resistance flatness	$r_{on(flat)}$	$0 \leq V_{NO} \leq V_+$, $I_{COM} = -100 \text{ mA}$	Switch ON, See Figure 13	25°C	3 V	0.3		Ω	
				25°C		0.15	0.25		
				Full		0.25			
NO OFF leakage current	$I_{NO(OFF)}$	$V_{NO} = 1 \text{ V}, V_{COM} = 3 \text{ V}$, or $V_{NO} = 3 \text{ V}, V_{COM} = 1 \text{ V}$,	Switch OFF, See Figure 14	25°C	3.6 V	-5	0.5	5	nA
				Full		-50	50		
	$I_{NO(PWROFF)}$	$V_{NO} = 0 \text{ to } 3.6 \text{ V}$, $V_{COM} = 3.6 \text{ V to } 0$,	Switch OFF, See Figure 14	25°C	0 V	-5	0.1	5	μA
				Full		-25	25		
COM OFF leakage current	$I_{COM(OFF)}$	$V_{COM} = 1 \text{ V}, V_{NO} = 3 \text{ V}$, or $V_{COM} = 3 \text{ V}, V_{NO} = 1 \text{ V}$,	Switch OFF, See Figure 14	25°C	3.6 V	-5	0.5	5	nA
				Full		-50	50		
	$I_{COM(PWROFF)}$	$V_{COM} = 0 \text{ to } 3.6 \text{ V}$, $V_{NO} = 3.6 \text{ V to } 0$,	Switch OFF, See Figure 14	25°C	0 V	-5	0.1	5	μA
				Full		-25	25		
NO ON leakage current	$I_{NO(ON)}$	$V_{NO} = 1 \text{ V}$, $V_{COM} = \text{Open}$, or $V_{NO} = 3 \text{ V}$, $V_{COM} = \text{Open}$,	Switch ON, See Figure 15	25°C	3.6 V	-2	0.3	2	nA
				Full		-20	20		
COM ON leakage current	$I_{COM(ON)}$	$V_{COM} = 1 \text{ V}$, $V_{NO} = \text{Open}$, or $V_{COM} = 3 \text{ V}$, $V_{NO} = \text{Open}$,	Switch ON, See Figure 15	25°C	3.6 V	-2	0.3	2	nA
				Full		-20	20		
Digital Control Inputs (IN1, IN2)⁽²⁾									
Input logic high	V_{IH}		Full		2		5.5	V	
Input logic low	V_{IL}		Full		0		0.8	V	
Input leakage current	I_{IH}, I_{IL}	$V_I = 5.5 \text{ V or } 0$	25°C	3.6 V	-2	0.3	2	nA	
			Full		-20	20			

(1) The algebraic convention, whereby the most negative value is a minimum and the most positive value is a maximum

(2) All unused digital inputs of the device must be held at V_+ or GND to ensure proper device operation. Refer to the TI application report, *Implications of Slow or Floating CMOS Inputs*, literature number SCBA004.

TS5A23166
0.9-Ω DUAL SPST ANALOG SWITCH
5-V/3.3-V 2-CHANNEL ANALOG SWITCH



SCDS196–MAY 2005

Electrical Characteristics for 3.3-V Supply⁽¹⁾ (continued)

$V_+ = 4.5\text{ V to }5.5\text{ V}$, $T_A = -40^\circ\text{C to }85^\circ\text{C}$ (unless otherwise noted)

PARAMETER	SYMBOL	TEST CONDITIONS	T_A	V_+	MIN	TYP	MAX	UNIT
Dynamic								
Turn-on time	t_{ON}	$V_{COM} = V_+$, $R_L = 50\ \Omega$, $C_L = 35\text{ pF}$, See Figure 17	25°C	3.3 V	1.5	5	9.5	ns
			Full	3 V to 3.6 V	1		10	
Turn-off time	t_{OFF}	$V_{COM} = V_+$, $R_L = 50\ \Omega$, $C_L = 35\text{ pF}$, See Figure 17	25°C	3.3 V	4.5	8.5	11	ns
			Full	3 V to 3.6 V	3		12.5	
Charge injection	Q_C	$V_{GEN} = 0$, $R_{GEN} = 0$, $C_L = 1\text{ nF}$, See Figure 21	25°C	5 V		6		pC
NO OFF capacitance	$C_{NO(OFF)}$	$V_{NO} = V_+$ or GND, Switch OFF, See Figure 16	25°C	3.3 V		19.5		pF
COM OFF capacitance	$C_{COM(OFF)}$	$V_{COM} = V_+$ or GND, Switch OFF, See Figure 16	25°C	3.3 V		18.5		pF
NO ON capacitance	$C_{NO(ON)}$	$V_{NO} = V_+$ or GND, Switch ON, See Figure 16	25°C	3.3 V		36		pF
COM ON capacitance	$C_{COM(ON)}$	$V_{COM} = V_+$ or GND, Switch ON, See Figure 16	25°C	3.3 V		36		pF
Digital input capacitance	C_I	$V_I = V_+$ or GND, See Figure 16	25°C	3.3 V		2		pF
Bandwidth	BW	$R_L = 50\ \Omega$, Switch ON, See Figure 18	25°C	3.3 V		150		MHz
OFF isolation	O_{ISO}	$R_L = 50\ \Omega$, $f = 1\text{ MHz}$, Switch OFF, See Figure 19	25°C	3.3 V		-62		dB
Crosstalk	X_{TALK}	$R_L = 50\ \Omega$, $f = 1\text{ MHz}$, Switch ON, See Figure 20	25°C	3.3 V		-85		dB
Total harmonic distortion	THD	$R_L = 600\ \Omega$, $C_L = 50\text{ pF}$, $f = 20\text{ Hz to }20\text{ kHz}$, See Figure 22	25°C	3.3 V		0.01		%
Supply								
Positive supply current	I_+	$V_I = V_+$ or GND, Switch ON or OFF	25°C	3.6 V	0.001	0.05		μA
			Full			0.3		

(1) The algebraic convention, whereby the most negative value is a minimum and the most positive value is a maximum

Electrical Characteristics for 2.5-V Supply⁽¹⁾
 $V_+ = 2.3 \text{ V to } 2.7 \text{ V}$, $T_A = -40^\circ\text{C to } 85^\circ\text{C}$ (unless otherwise noted)

PARAMETER	SYMBOL	TEST CONDITIONS	T_A	V_+	MIN	TYP	MAX	UNIT	
Analog Switch									
Analog signal range	V_{COM}, V_{NO}				0		V_+	V	
Peak ON resistance	r_{peak}	$0 \leq V_{NO} \leq V_+$, $I_{COM} = -8 \text{ mA}$, Switch ON, See Figure 13	25°C	2.3 V		1.8	2.4	Ω	
			Full				2.6		
ON-state resistance	r_{on}	$V_{NO} = 1.8 \text{ V}$, $I_{COM} = -8 \text{ mA}$, Switch ON, See Figure 13	25°C	2.3 V		1.2	2.1	Ω	
			Full				2.4		
ON-state resistance match between channels	Δr_{on}	$V_{NO} = 1.8 \text{ V}, 0.8 \text{ V}$, $I_{COM} = -8 \text{ mA}$, Switch ON, See Figure 13	25°C	2.3 V		0.04	0.15	Ω	
			Full				0.15		
ON-state resistance flatness	$r_{on (flat)}$	$0 \leq V_{NO} \leq V_+$, $I_{COM} = -8 \text{ mA}$, Switch ON, See Figure 13	25°C	2.3 V		0.7		Ω	
			Full		25°C		0.4		0.6
									0.6
NO OFF leakage current	$I_{NO(OFF)}$	$V_{NO} = 0.5 \text{ V}$, $V_{COM} = 2.3 \text{ V}$, or $V_{NO} = 2.3 \text{ V}$, $V_{COM} = 0.5 \text{ V}$, Switch OFF, See Figure 14	25°C	2.7 V		-5	0.3	5	nA
			Full				-50	50	
	$I_{NO(PWROFF)}$	$V_{NO} = 0 \text{ to } 2.7 \text{ V}$, $V_{COM} = 2.7 \text{ V to } 0$, Switch OFF, See Figure 14	25°C	0 V		-2	0.05	2	μA
			Full				-15	15	
COM OFF leakage current	$I_{COM(OFF)}$	$V_{NO} = 2.3 \text{ V}$, $V_{COM} = 0.5 \text{ V}$, or $V_{NO} = 0.5 \text{ V}$, $V_{COM} = 2.3 \text{ V}$, Switch OFF, See Figure 14	25°C	2.7 V		-5	0.3	5	nA
			Full				-50	50	
	$I_{COM(PWROFF)}$	$V_{COM} = 0 \text{ to } 2.7 \text{ V}$, $V_{NO} = 2.7 \text{ V to } 0$, Switch OFF, See Figure 14	25°C	0 V		-2	0.05	2	μA
			Full				-15	15	
NO ON leakage current	$I_{NO(ON)}$	$V_{NO} = 0.5 \text{ V}$, $V_{COM} = \text{Open}$, or $V_{NO} = 2.3 \text{ V}$, $V_{COM} = \text{Open}$, Switch ON, See Figure 15	25°C	2.7 V		-2	0.3	2	nA
			Full				-20	20	
COM ON leakage current	$I_{COM(ON)}$	$V_{COM} = 0.5 \text{ V}$, $V_{NO} = \text{Open}$, or $V_{COM} = 2.3 \text{ V}$, $V_{NO} = \text{Open}$, Switch ON, See Figure 15	25°C	2.7 V		-2	0.3	2	nA
			Full				-20	20	
Digital Control Inputs (IN1, IN2)									
Input logic high	V_{IH}		Full		1.8		5.5	V	
Input logic low	V_{IL}		Full		0		0.6	V	
Input leakage current	I_{IH}, I_{IL}	$V_I = 5.5 \text{ V or } 0$	25°C	2.7 V		-2	0.3	2	nA
			Full				-20	20	

(1) The algebraic convention is used in this data sheet; the most negative value is shown in the minimum column.

TS5A23166
0.9-Ω DUAL SPST ANALOG SWITCH
5-V/3.3-V 2-CHANNEL ANALOG SWITCH



SCDS196–MAY 2005

Electrical Characteristics for 2.5-V Supply⁽¹⁾ (continued)

$V_+ = 2.3 \text{ V to } 2.7 \text{ V}$, $T_A = -40^\circ\text{C to } 85^\circ\text{C}$ (unless otherwise noted)

PARAMETER	SYMBOL	TEST CONDITIONS	T_A	V_+	MIN	TYP	MAX	UNIT
Dynamic								
Turn-on time	t_{ON}	$V_{COM} = V_+$, $R_L = 50 \Omega$, $C_L = 35 \text{ pF}$, See Figure 17	25°C	2.5 V	2	6	10	ns
			Full	2.3 V to 2.7 V	1		12	
Turn-off time	t_{OFF}	$V_{COM} = V_+$, $R_L = 50 \Omega$, $C_L = 35 \text{ pF}$, See Figure 17	25°C	2.5 V	4.5	8	12.5	ns
			Full	2.3 V to 2.7 V	3		15	
Charge injection	Q_C	$V_{GEN} = 0$, $R_{GEN} = 0$, $C_L = 1 \text{ nF}$, See Figure 21	25°C	2.5 V		4		pC
NO OFF capacitance	$C_{NO(OFF)}$	$V_{NO} = V_+$ or GND, Switch OFF, See Figure 16	25°C	2.5 V		19.5		pF
COM OFF capacitance	$C_{COM(OFF)}$	$V_{COM} = V_+$ or GND, Switch OFF, See Figure 16	25°C	2.5 V		18.5		pF
NO ON capacitance	$C_{NO(ON)}$	$V_{NO} = V_+$ or GND, Switch ON, See Figure 16	25°C	2.5 V		36.5		pF
COM ON capacitance	$C_{COM(ON)}$	$V_{COM} = V_+$ or GND, Switch ON, See Figure 16	25°C	2.5 V		36.5		pF
Digital input capacitance	C_I	$V_I = V_+$ or GND, See Figure 16	25°C	2.5 V		2		pF
Bandwidth	BW	$R_L = 50 \Omega$, Switch ON, See Figure 18	25°C	2.5 V		150		MHz
OFF isolation	O_{ISO}	$R_L = 50 \Omega$, $f = 1 \text{ MHz}$, Switch OFF, See Figure 19	25°C	2.5 V		-62		dB
Crosstalk	X_{TALK}	$R_L = 50 \Omega$, $f = 1 \text{ MHz}$, Switch ON, See Figure 20	25°C	2.5 V		-85		dB
Total harmonic distortion	THD	$R_L = 600 \Omega$, $C_L = 50 \text{ pF}$, $f = 20 \text{ Hz to } 20 \text{ kHz}$, See Figure 22	25°C	2.5 V		0.02		%
Supply								
Positive supply current	I_+	$V_I = V_+$ or GND, Switch ON or OFF	25°C	2.7 V	0.001	0.02	0.25	μA
			Full					

(1) The algebraic convention is used in this data sheet; the most negative value is shown in the minimum column.

Electrical Characteristics for 1.8-V Supply⁽¹⁾
 $V_+ = 1.65\text{ V to }1.95\text{ V}$, $T_A = -40^\circ\text{C to }85^\circ\text{C}$ (unless otherwise noted)

PARAMETER	SYMBOL	TEST CONDITIONS	T_A	V_+	MIN	TYP	MAX	UNIT
Analog Switch								
Analog signal range	V_{COM}, V_{NO}				0		V_+	V
Peak ON resistance	r_{peak}	$0 \leq V_{NO} \leq V_+$, $I_{COM} = -2\text{ mA}$, Switch ON, See Figure 13	25°C	1.65 V	4.2		25	Ω
			Full				30	
ON-state resistance	r_{on}	$V_{NO} = 0.6\text{ V}, 1.5\text{ V}$, $I_{COM} = -2\text{ mA}$, Switch ON, See Figure 13	25°C	1.65 V	1.6		3.9	Ω
			Full				4	
ON-state resistance match between channels	Δr_{on}	$V_{NO} = 1.5\text{ V}$, $I_{COM} = -2\text{ mA}$, Switch ON, See Figure 13	25°C	1.65 V	0.04		0.2	Ω
			Full				0.2	
ON-state resistance flatness	$r_{on (flat)}$	$0 \leq V_{NO} \leq V_+$, $I_{COM} = -2\text{ mA}$, $V_{NO} = 0.6\text{ V}, 1.5\text{ V}$, $I_{COM} = -2\text{ mA}$, Switch ON, See Figure 13	25°C	1.65 V	2.8			Ω
			Full				4.1	
NO OFF leakage current	$I_{NO(OFF)}$	$V_{NO} = 0.3\text{ V}$, $V_{COM} = 1.65\text{ V}$, or $V_{NO} = 1.65\text{ V}$, $V_{COM} = 0.3\text{ V}$, Switch OFF, See Figure 14	25°C	1.95 V	-5	0.3	5	nA
			Full				-50	
	$I_{NO(PWROFF)}$	$V_{NO} = 0\text{ to }1.95\text{ V}$, $V_{COM} = 1.95\text{ V to }0$, Switch OFF, See Figure 14	25°C	0 V	-2	0.05	2	μA
			Full				-10	
COM OFF leakage current	$I_{COM(OFF)}$	$V_{NO} = 1.65\text{ V}$, $V_{COM} = 0.3\text{ V}$, or $V_{NO} = 0.3\text{ V}$, $V_{COM} = 1.65\text{ V}$, Switch OFF, See Figure 14	25°C	1.95 V	-5	0.3	5	nA
			Full				-50	
	$I_{COM(PWROFF)}$	$V_{COM} = 0\text{ to }1.95\text{ V}$, $V_{NO} = 1.95\text{ V to }0$, Switch OFF, See Figure 14	25°C	0 V	-2	0.05	2	μA
			Full				-10	
NO ON leakage current	$I_{NO(ON)}$	$V_{NO} = 0.3\text{ V}$, $V_{COM} = \text{Open}$, or $V_{NO} = 1.65\text{ V}$, $V_{COM} = \text{Open}$, Switch ON, See Figure 15	25°C	1.95 V	-2	0.3	2	nA
			Full				-20	
COM ON leakage current	$I_{COM(ON)}$	$V_{NO} = \text{Open}$, $V_{COM} = 0.3\text{ V}$, or $V_{NO} = \text{Open}$, $V_{COM} = 1.65\text{ V}$, Switch ON, See Figure 15	25°C	1.95 V	-2	0.3	2	nA
			Full				-20	
Digital Control Inputs (IN1, IN2)								
Input logic high	V_{IH}		Full		1.5		5.5	V
Input logic low	V_{IL}		Full		0		0.6	V
Input leakage current	I_{IH}, I_{IL}	$V_I = 5.5\text{ V or }0$	25°C	1.95 V	-2	0.3	2	μA
			Full				-20	

(1) The algebraic convention is used in this data sheet; the most negative value is shown in the minimum column.

TS5A23166
0.9-Ω DUAL SPST ANALOG SWITCH
5-V/3.3-V 2-CHANNEL ANALOG SWITCH



SCDS196–MAY 2005

Electrical Characteristics for 1.8-V Supply⁽¹⁾ (continued)

$V_+ = 1.65\text{ V to }1.95\text{ V}$, $T_A = -40^\circ\text{C to }85^\circ\text{C}$ (unless otherwise noted)

PARAMETER	SYMBOL	TEST CONDITIONS	T_A	V_+	MIN	TYP	MAX	UNIT
Dynamic								
Turn-on time	t_{ON}	$V_{COM} = V_+$, $R_L = 50\ \Omega$, $C_L = 35\text{ pF}$, See Figure 17	25°C	1.8 V	3	9	18	ns
			Full	1.65 V to 1.95 V	1		20	
Turn-off time	t_{OFF}	$V_{COM} = V_+$, $R_L = 50\ \Omega$, $C_L = 35\text{ pF}$, See Figure 17	25°C	1.8 V	5	10	15.5	ns
			Full	1.65 V to 1.95 V	4		18.5	
Charge injection	Q_C	$V_{GEN} = 0$, $R_{GEN} = 0$, $C_L = 1\text{ nF}$, See Figure 21	25°C	1.8 V		2		pC
NO OFF capacitance	$C_{NO(OFF)}$	$V_{NO} = V_+$ or GND, Switch OFF, See Figure 16	25°C	1.8 V		19.5		pF
COM OFF capacitance	$C_{COM(OFF)}$	$V_{COM} = V_+$ or GND, Switch OFF, See Figure 16	25°C	1.8 V		18.5		pF
NO ON capacitance	$C_{NO(ON)}$	$V_{NO} = V_+$ or GND, Switch ON, See Figure 16	25°C	1.8 V		36.5		pF
COM ON capacitance	$C_{COM(ON)}$	$V_{COM} = V_+$ or GND, Switch ON, See Figure 16	25°C	1.8 V		36.5		pF
Digital input capacitance	C_I	$V_I = V_+$ or GND, See Figure 16	25°C	1.8 V		2		pF
Bandwidth	BW	$R_L = 50\ \Omega$, Switch ON, See Figure 18	25°C	1.8 V		150		MHz
OFF isolation	O_{ISO}	$R_L = 50\ \Omega$, $f = 1\text{ MHz}$, Switch OFF, See Figure 19	25°C	1.8 V		-62		dB
Total harmonic distortion	THD	$R_L = 600\ \Omega$, $C_L = 50\text{ pF}$, $f = 20\text{ Hz to }20\text{ kHz}$, See Figure 22	25°C	1.8 V		0.055		%
Supply								
Positive supply current	I_+	$V_I = V_+$ or GND, Switch ON or OFF	25°C	1.95 V		0.001	0.01	μA
			Full				0.15	

(1) The algebraic convention is used in this data sheet; the most negative value is shown in the minimum column.

TYPICAL PERFORMANCE

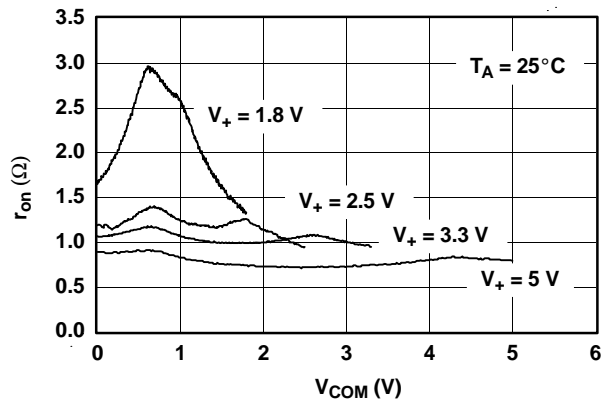

Figure 1. r_{on} vs V_{COM}

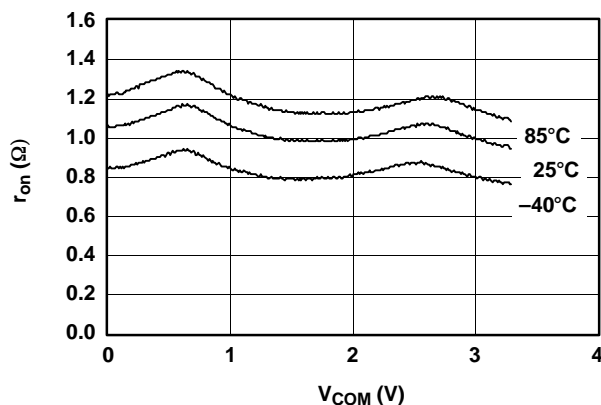

Figure 2. r_{on} vs V_{COM} ($V_+ = 3.3\text{ V}$)

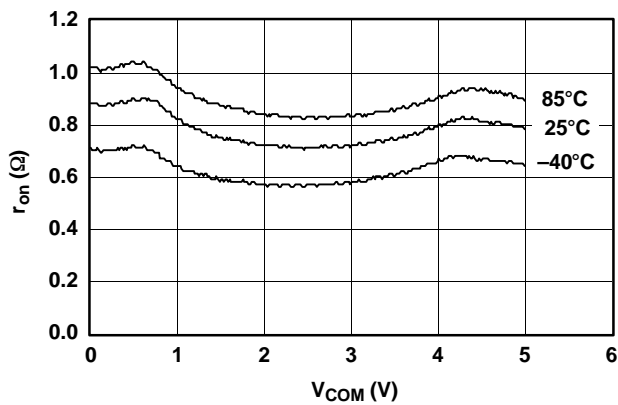

Figure 3. r_{on} vs V_{COM} ($V_+ = 5\text{ V}$)

TYPICAL PERFORMANCE

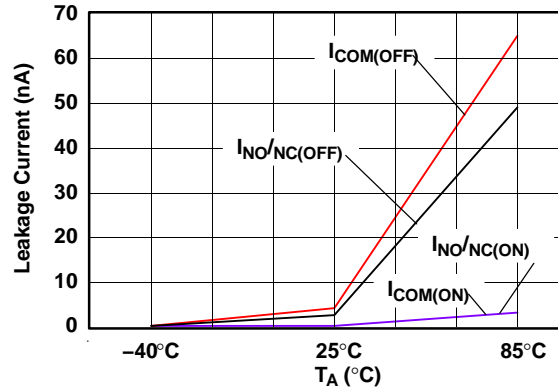

Figure 4. Leakage Current vs Temperature ($V_+ = 5.5\text{ V}$)

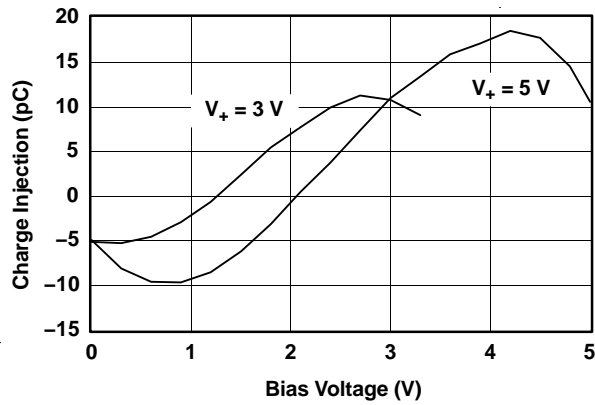

Figure 5. Charge Injection (Q_C) vs V_{COM}

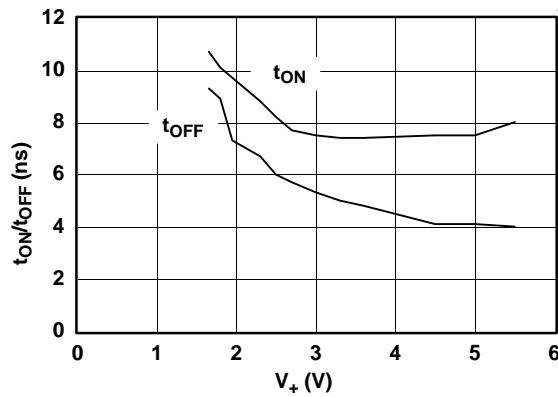

Figure 6. t_{ON} and t_{OFF} vs Supply Voltage

TYPICAL PERFORMANCE

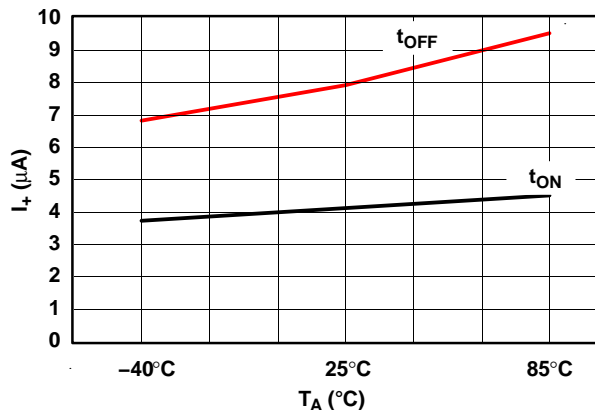

Figure 7. t_{ON} and t_{OFF} vs Temperature (V₊ = 5 V)

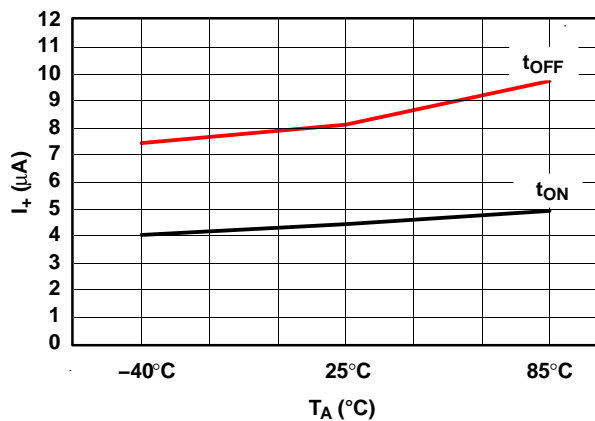

Figure 8. Logic-Level Theshold vs V₊

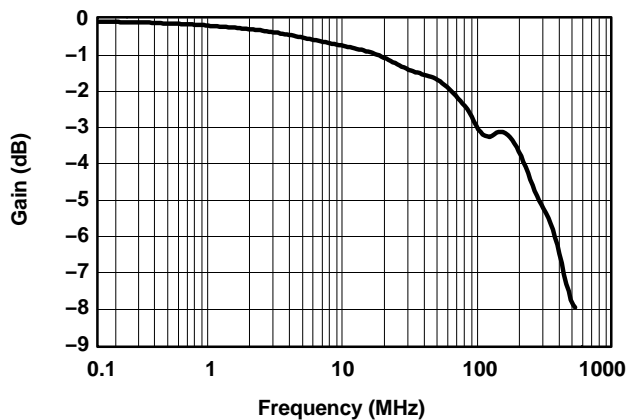

Figure 9. Bandwidth (V₊ = 5 V)

TYPICAL PERFORMANCE

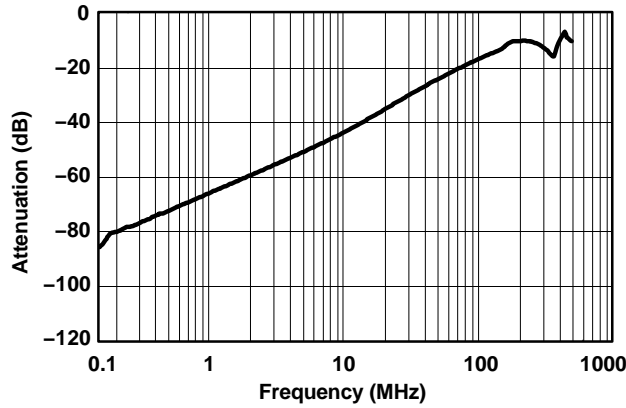

Figure 10. OFF Isolation and Crosstalk ($V_+ = 5\text{ V}$)

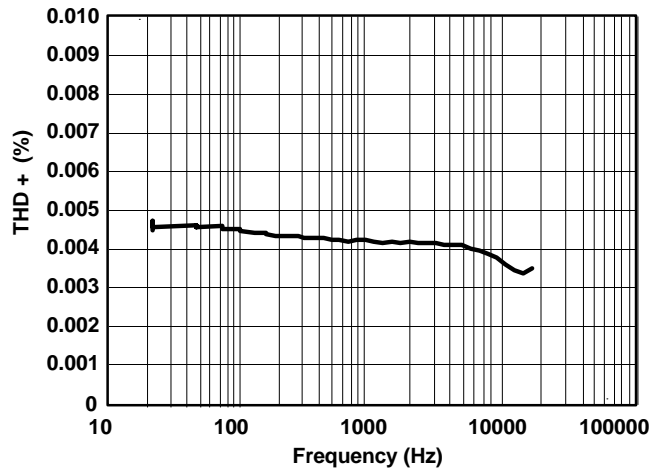

Figure 11. Total Harmonic Distortion vs Frequency

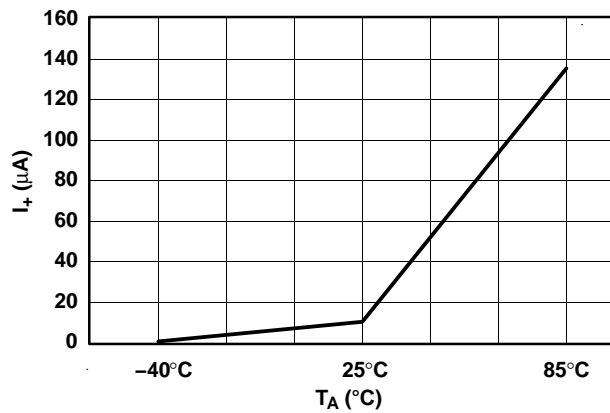

Figure 12. Power-Supply Current vs Temperature ($V_+ = 5\text{ V}$)

PIN DESCRIPTION

PIN NUMBER	NAME	DESCRIPTION
1	NO1	Normally closed
2	COM1	Common
3	IN2	Digital control pin to connect COM to NO
4	GND	Digital ground
5	NO2	Normally closed
6	COM2	Common
7	IN1	Digital control pin to connect COM to NO
8	V ₊	Power Supply

PARAMETER DESCRIPTION

SYMBOL	DESCRIPTION
V _{COM}	Voltage at COM
V _{NO}	Voltage at NO
r _{on}	Resistance between COM and NO ports when the channel is ON
r _{on(flat)}	Difference between the maximum and minimum value of r _{on} in a channel over the specified range of conditions
I _{NO(OFF)}	Leakage current measured at the NO port, with the corresponding channel (NO to COM) in the OFF state
I _{NO(ON)}	Leakage current measured at the NO port, with the corresponding channel (NO to COM) in the ON state and the output (COM) open
I _{COM(OFF)}	Leakage current measured at the COM port, with the corresponding channel (COM to NO) in the OFF state
I _{COM(ON)}	Leakage current measured at the COM port, with the corresponding channel (COM to NO) in the ON state and the output (NO) open
V _{IH}	Minimum input voltage for logic high for the control input (IN)
V _{IL}	Maximum input voltage for logic low for the control input (IN)
V _I	Voltage at the control input (IN)
I _{IH} , I _{IL}	Leakage current measured at the control input (IN)
t _{ON}	Turn-on time for the switch. This parameter is measured under the specified range of conditions and by the propagation delay between the digital control (IN) signal and analog output (COM or NO) signal when the switch is turning ON.
t _{OFF}	Turn-off time for the switch. This parameter is measured under the specified range of conditions and by the propagation delay between the digital control (IN) signal and analog output (COM or NO) signal when the switch is turning OFF.
Q _C	Charge injection is a measurement of unwanted signal coupling from the control (IN) input to the analog (NO or COM) output. This is measured in coulomb (C) and measured by the total charge induced due to switching of the control input. Charge injection, Q _C = C _L × ΔV _{COM} , C _L is the load capacitance and ΔV _{COM} is the change in analog output voltage.
C _{NO(OFF)}	Capacitance at the NO port when the corresponding channel (NO to COM) is OFF
C _{NO(ON)}	Capacitance at the NO port when the corresponding channel (NO to COM) is ON
C _{COM(OFF)}	Capacitance at the COM port when the corresponding channel (COM to NO) is OFF
C _{COM(ON)}	Capacitance at the COM port when the corresponding channel (COM to NO) is ON
C _I	Capacitance of IN
O _{ISO}	OFF isolation of the switch is a measurement of OFF-state switch impedance. This is measured in dB in a specific frequency, with the corresponding channel (NO to COM) in the OFF state.
BW	Bandwidth of the switch. This is the frequency in which the gain of an ON channel is –3 dB below the DC gain.
THD	Total harmonic distortion is defined as the ratio of the root mean square (RMS) value of the second, third, and higher harmonics to the magnitude of fundamental harmonic.
I ₊	Static power-supply current with the control (IN) pin at V ₊ or GND
ΔI ₊	This is the increase in I ₊ for each control (IN) input that is at the specified voltage, rather than at V ₊ or GND.

PARAMETER MEASUREMENT INFORMATION

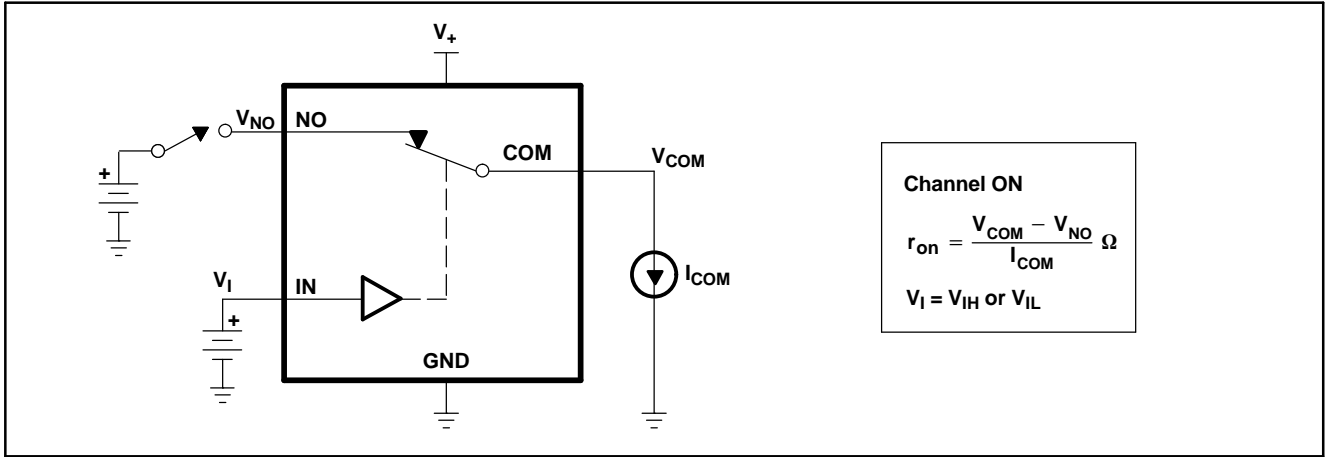

Figure 13. ON-State Resistance (r_{on})

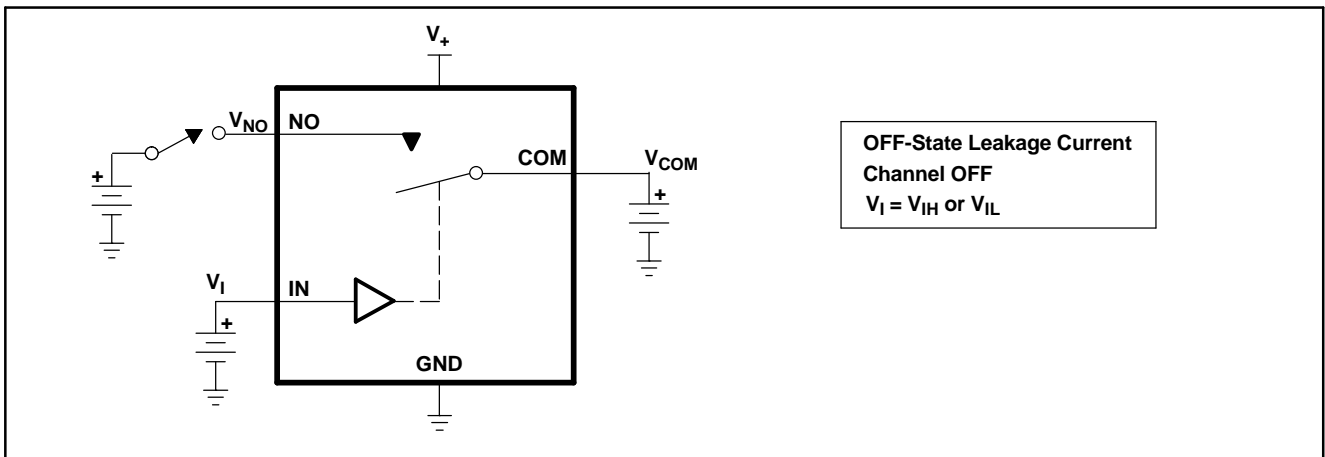

Figure 14. OFF-State Leakage Current ($I_{COM(OFF)}$, $I_{NC(OFF)}$, $I_{COM(PWROFF)}$, $I_{NC(PWRFF)}$)

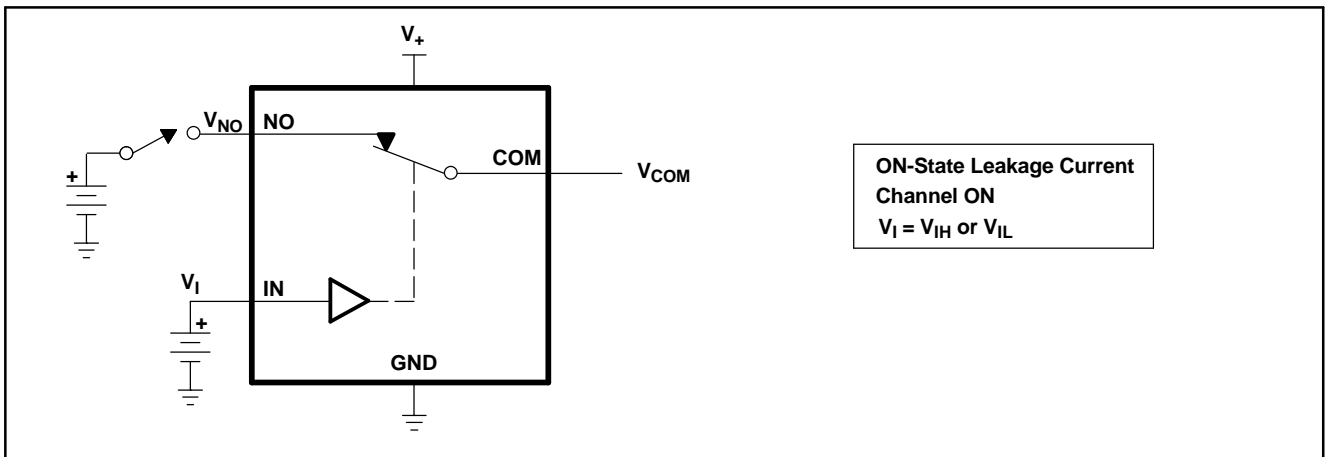

Figure 15. ON-State Leakage Current ($I_{COM(ON)}$, $I_{NC(ON)}$)

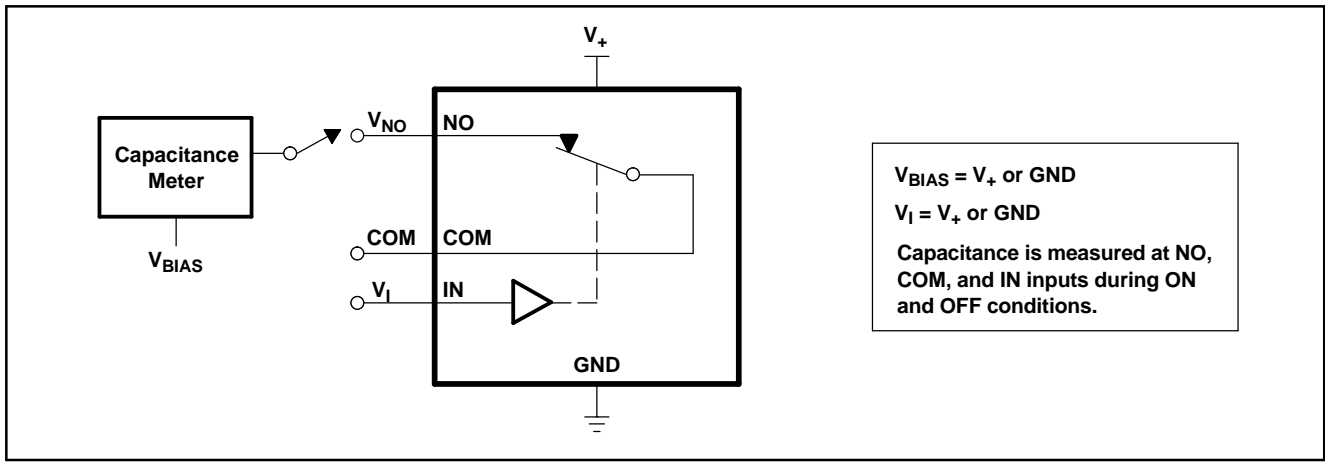
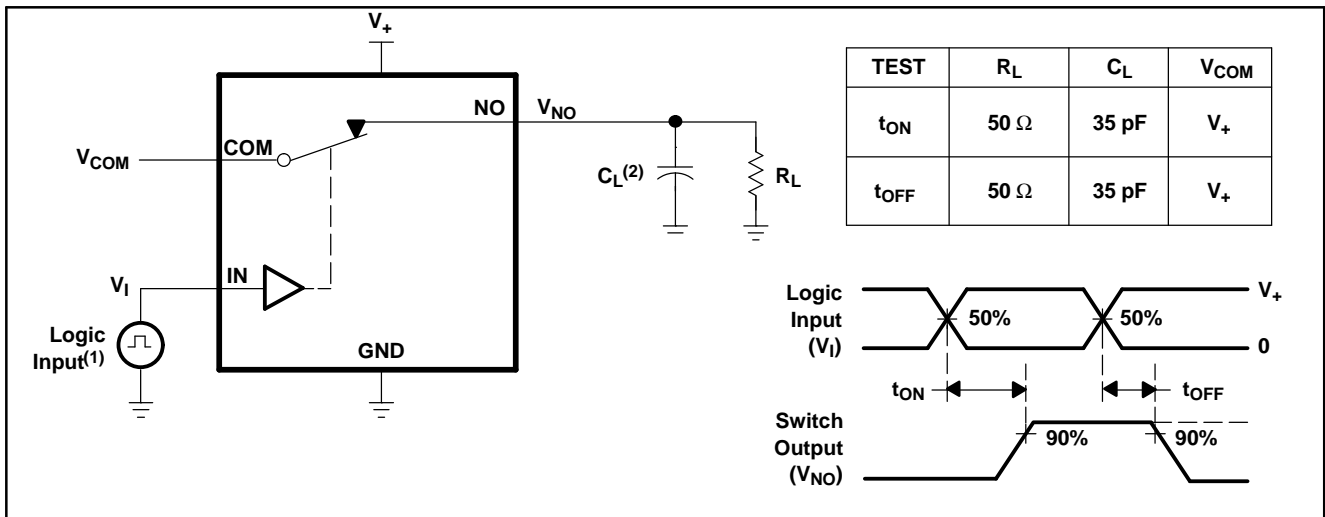

Figure 16. Capacitance (C_I , $C_{COM(OFF)}$, $C_{COM(ON)}$, $C_{NC(OFF)}$, $C_{NC(ON)}$)



(1) All input pulses are supplied by generators having the following characteristics: PRR \leq 10 MHz, $Z_O = 50 \Omega$, $t_r < 5$ ns, $t_f < 5$ ns.

(2) C_L includes probe and jig capacitance.

Figure 17. Turn-On (t_{ON}) and Turn-Off Time (t_{OFF})

TS5A23166
0.9-Ω DUAL SPST ANALOG SWITCH
5-V/3.3-V 2-CHANNEL ANALOG SWITCH

SCDS196–MAY 2005

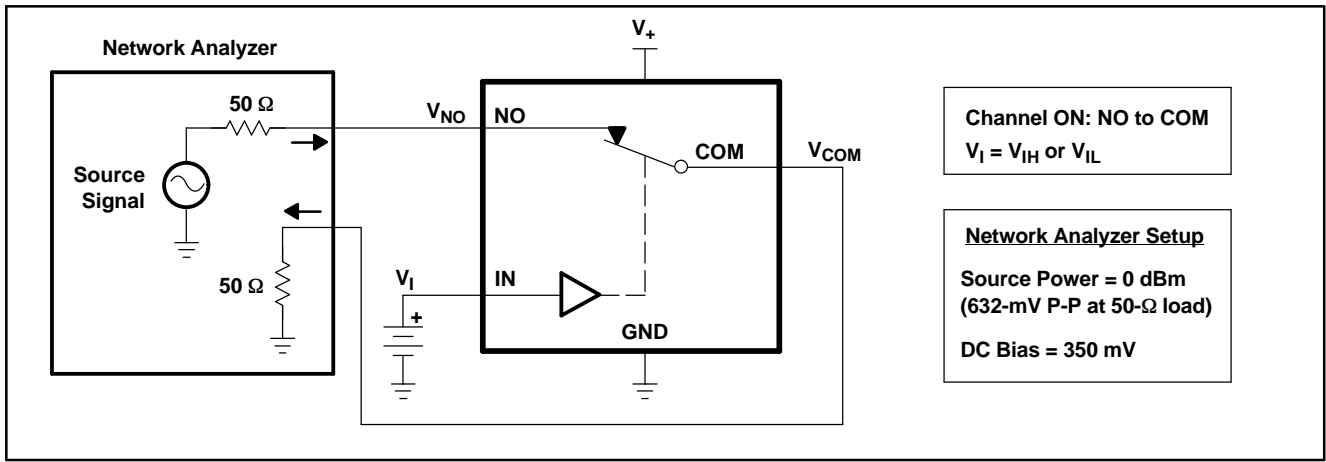

Figure 18. Bandwidth (BW)

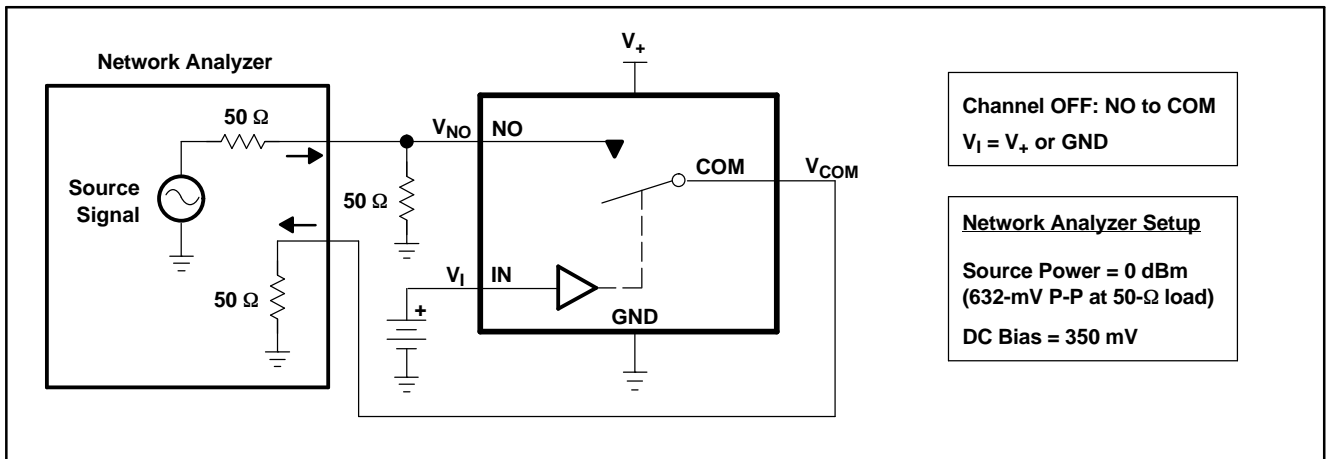

Figure 19. OFF Isolation (O_{ISO})

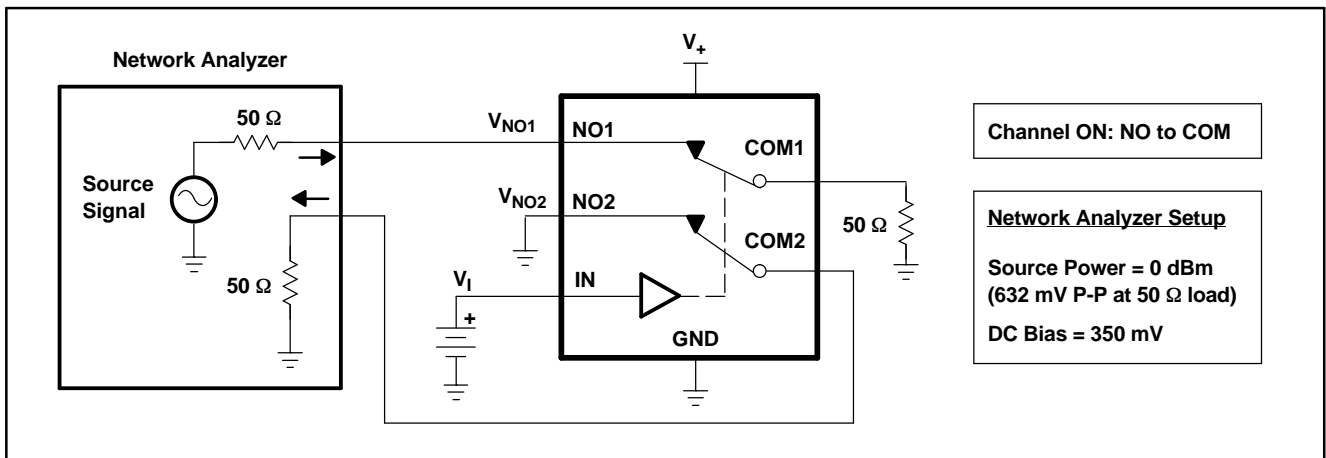
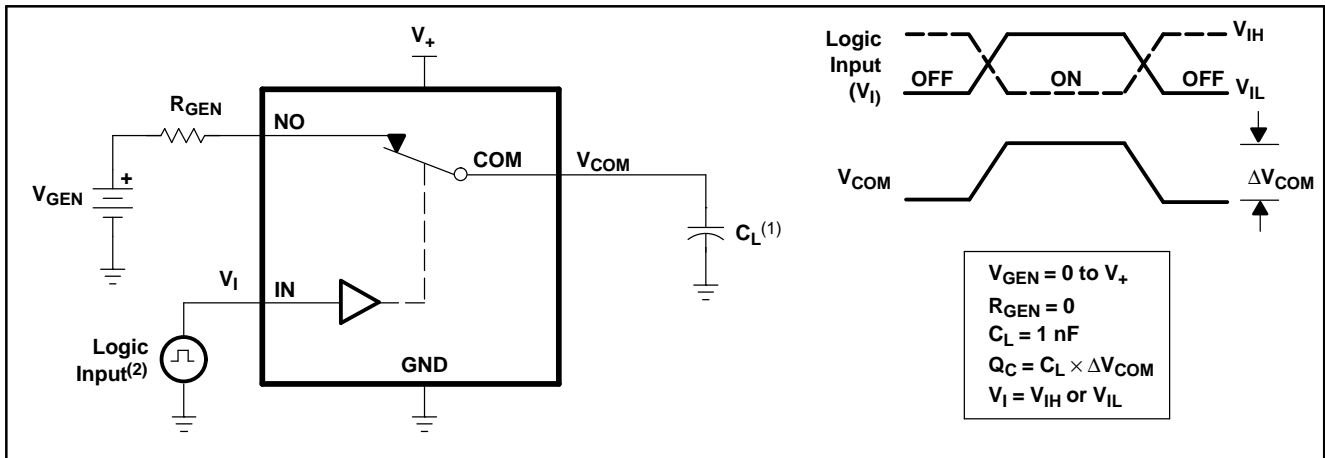

Figure 20. Crosstalk (X_{TALK})



(1) C_L includes probe and jig capacitance.

(2) All input pulses are supplied by generators having the following characteristics: $PRR \leq 10$ MHz, $Z_O = 50 \Omega$, $t_r < 5$ ns, $t_f < 5$ ns.

Figure 21. Charge Injection (Q_C)

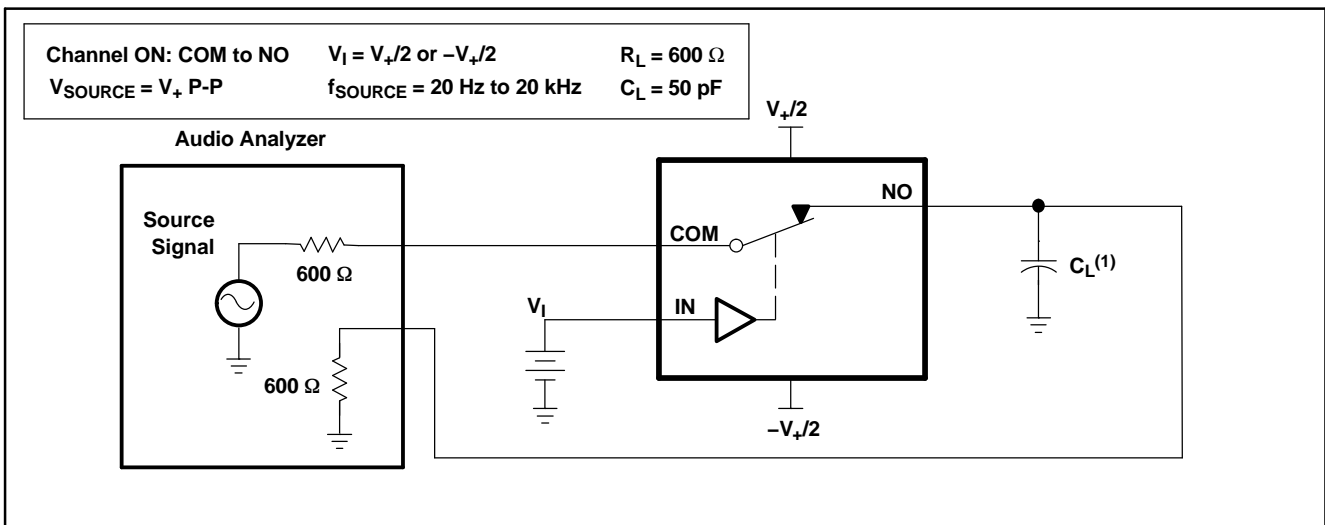

(1) C_L includes probe and jig capacitance.

Figure 22. Total Harmonic Distortion (THD)

PACKAGING INFORMATION

Orderable Device	Status ⁽¹⁾	Package Type	Package Drawing	Pins	Package Qty	Eco Plan ⁽²⁾	Lead/Ball Finish	MSL Peak Temp ⁽³⁾
TS5A23166DCUR	ACTIVE	US8	DCU	8	3000	Pb-Free (RoHS)	CU NIPDAU	Level-1-260C-UNLIM
TS5A23166DCURE4	ACTIVE	US8	DCU	8	3000	Pb-Free (RoHS)	CU NIPDAU	Level-1-260C-UNLIM

⁽¹⁾ The marketing status values are defined as follows:

ACTIVE: Product device recommended for new designs.

LIFEBUY: TI has announced that the device will be discontinued, and a lifetime-buy period is in effect.

NRND: Not recommended for new designs. Device is in production to support existing customers, but TI does not recommend using this part in a new design.

PREVIEW: Device has been announced but is not in production. Samples may or may not be available.

OBSOLETE: TI has discontinued the production of the device.

⁽²⁾ Eco Plan - The planned eco-friendly classification: Pb-Free (RoHS) or Green (RoHS & no Sb/Br) - please check <http://www.ti.com/productcontent> for the latest availability information and additional product content details.

TBD: The Pb-Free/Green conversion plan has not been defined.

Pb-Free (RoHS): TI's terms "Lead-Free" or "Pb-Free" mean semiconductor products that are compatible with the current RoHS requirements for all 6 substances, including the requirement that lead not exceed 0.1% by weight in homogeneous materials. Where designed to be soldered at high temperatures, TI Pb-Free products are suitable for use in specified lead-free processes.

Green (RoHS & no Sb/Br): TI defines "Green" to mean Pb-Free (RoHS compatible), and free of Bromine (Br) and Antimony (Sb) based flame retardants (Br or Sb do not exceed 0.1% by weight in homogeneous material)

⁽³⁾ MSL, Peak Temp. -- The Moisture Sensitivity Level rating according to the JEDEC industry standard classifications, and peak solder temperature.

Important Information and Disclaimer:The information provided on this page represents TI's knowledge and belief as of the date that it is provided. TI bases its knowledge and belief on information provided by third parties, and makes no representation or warranty as to the accuracy of such information. Efforts are underway to better integrate information from third parties. TI has taken and continues to take reasonable steps to provide representative and accurate information but may not have conducted destructive testing or chemical analysis on incoming materials and chemicals. TI and TI suppliers consider certain information to be proprietary, and thus CAS numbers and other limited information may not be available for release.

In no event shall TI's liability arising out of such information exceed the total purchase price of the TI part(s) at issue in this document sold by TI to Customer on an annual basis.

MECHANICAL DATA

DCU (R-PDSO-G8)

PLASTIC SMALL-OUTLINE PACKAGE (DIE DOWN)

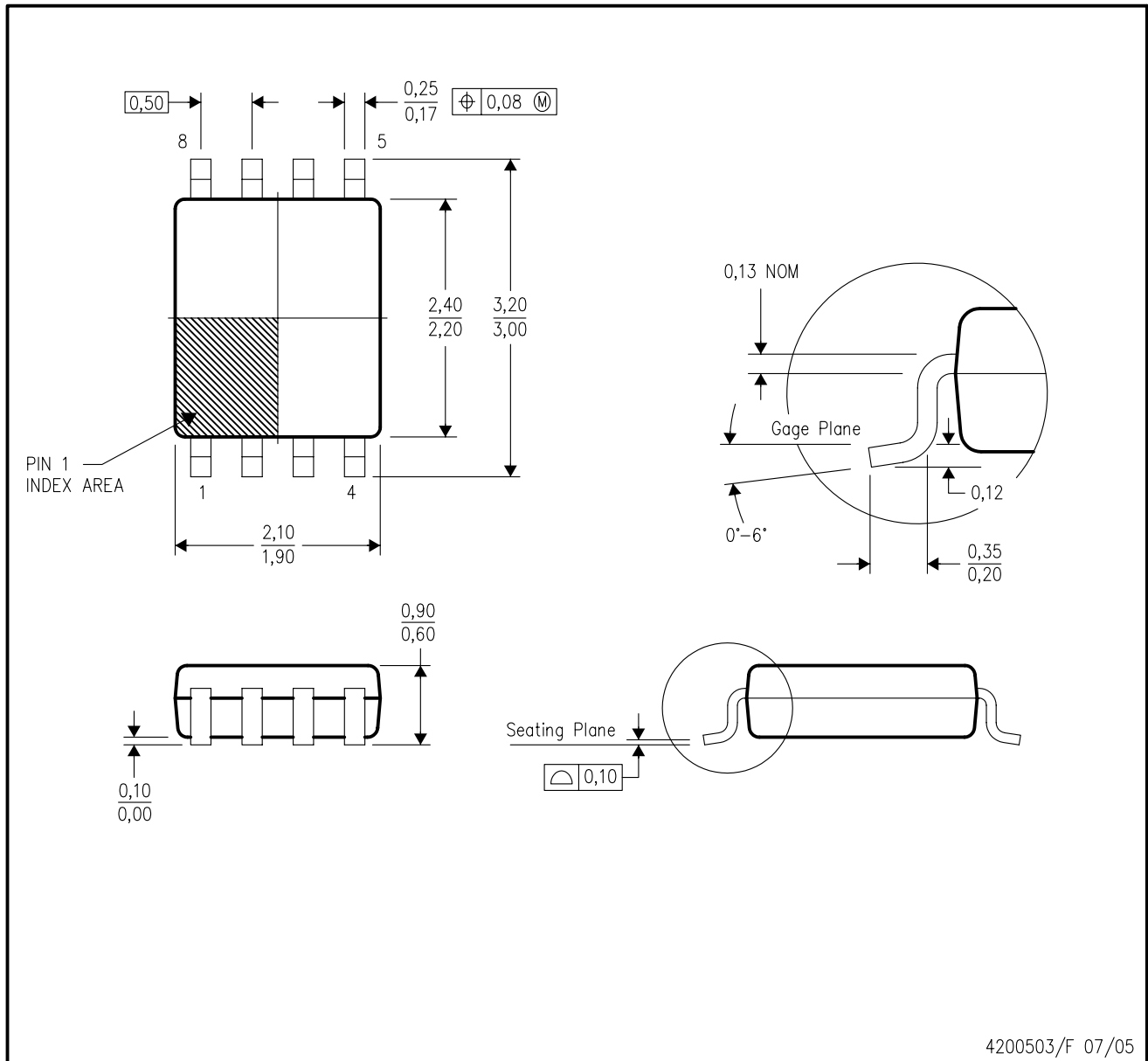

4200503/F 07/05

- NOTES:
- All linear dimensions are in millimeters.
 - This drawing is subject to change without notice.
 - Body dimensions do not include mold flash or protrusion. Mold flash and protrusion shall not exceed 0.15 per side.
 - Falls within JEDEC MO-187 variation CA.

IMPORTANT NOTICE

Texas Instruments Incorporated and its subsidiaries (TI) reserve the right to make corrections, modifications, enhancements, improvements, and other changes to its products and services at any time and to discontinue any product or service without notice. Customers should obtain the latest relevant information before placing orders and should verify that such information is current and complete. All products are sold subject to TI's terms and conditions of sale supplied at the time of order acknowledgment.

TI warrants performance of its hardware products to the specifications applicable at the time of sale in accordance with TI's standard warranty. Testing and other quality control techniques are used to the extent TI deems necessary to support this warranty. Except where mandated by government requirements, testing of all parameters of each product is not necessarily performed.

TI assumes no liability for applications assistance or customer product design. Customers are responsible for their products and applications using TI components. To minimize the risks associated with customer products and applications, customers should provide adequate design and operating safeguards.

TI does not warrant or represent that any license, either express or implied, is granted under any TI patent right, copyright, mask work right, or other TI intellectual property right relating to any combination, machine, or process in which TI products or services are used. Information published by TI regarding third-party products or services does not constitute a license from TI to use such products or services or a warranty or endorsement thereof. Use of such information may require a license from a third party under the patents or other intellectual property of the third party, or a license from TI under the patents or other intellectual property of TI.

Reproduction of information in TI data books or data sheets is permissible only if reproduction is without alteration and is accompanied by all associated warranties, conditions, limitations, and notices. Reproduction of this information with alteration is an unfair and deceptive business practice. TI is not responsible or liable for such altered documentation.

Resale of TI products or services with statements different from or beyond the parameters stated by TI for that product or service voids all express and any implied warranties for the associated TI product or service and is an unfair and deceptive business practice. TI is not responsible or liable for any such statements.

Following are URLs where you can obtain information on other Texas Instruments products and application solutions:

Products		Applications	
Amplifiers	amplifier.ti.com	Audio	www.ti.com/audio
Data Converters	dataconverter.ti.com	Automotive	www.ti.com/automotive
DSP	dsp.ti.com	Broadband	www.ti.com/broadband
Interface	interface.ti.com	Digital Control	www.ti.com/digitalcontrol
Logic	logic.ti.com	Military	www.ti.com/military
Power Mgmt	power.ti.com	Optical Networking	www.ti.com/opticalnetwork
Microcontrollers	microcontroller.ti.com	Security	www.ti.com/security
		Telephony	www.ti.com/telephony
		Video & Imaging	www.ti.com/video
		Wireless	www.ti.com/wireless

Mailing Address: Texas Instruments
Post Office Box 655303 Dallas, Texas 75265