	<h2 style="margin: 0;">TS650</h2> <h3 style="margin: 0;">Buck Switching Regulator</h3>																		
	<p>Pin assignment:</p> <ol style="list-style-type: none"> 1. Out 2. P.Gnd 3. CT 4. Gnd 5. FB 6. Vcc 7. Comp. 8. Enable 																		
<p>Supply Voltage Range 3 V to 30V</p> <p>Output Driving Current 500mA</p> <p>Oscillator Frequency up to 100KHz</p>																			
<h3>General Description</h3> <p>The TS650 is a monolithic buck switching regulator, it is consist of an voltage reference, error amplifier, current limited set by an external resistor, power forward modular controller and switching frequencies up to 100KHz are set by an external capacitor.</p> <p>Additionally, a chip enable feature is provided to power down reducing the supply current, and with a minimum number of external components, the TS650 offer a simple and cost effective solution.</p> <p>The TS650 is offered in SOP-8 package.</p>																			
<h3>Features</h3> <ul style="list-style-type: none"> ◇ Power forward control circuit ◇ Operating voltage form 3V to 30V ◇ Low standby current ◇ Current limit adjustable ◇ Output switch current up to 500mA ◇ Variable oscillator frequency up to 100KHz (max) ◇ Shut down control ◇ 1.25V voltage reference Output 	<h3>Pin Descriptions</h3> <table border="1" style="width: 100%; border-collapse: collapse;"> <thead> <tr> <th style="text-align: center;">Name</th> <th style="text-align: center;">Description</th> </tr> </thead> <tbody> <tr> <td style="text-align: center;">Output</td> <td>PWM Output</td> </tr> <tr> <td style="text-align: center;">P.Gnd</td> <td>Power Ground</td> </tr> <tr> <td style="text-align: center;">CT</td> <td>Oscillator Control</td> </tr> <tr> <td style="text-align: center;">Gnd</td> <td>Ground</td> </tr> <tr> <td style="text-align: center;">FB</td> <td>Voltage Feedback</td> </tr> <tr> <td style="text-align: center;">Vcc</td> <td>Power Supply</td> </tr> <tr> <td style="text-align: center;">Comp.</td> <td>Feedback Compensation</td> </tr> <tr> <td style="text-align: center;">Enable</td> <td>ON/OFF control</td> </tr> </tbody> </table>	Name	Description	Output	PWM Output	P.Gnd	Power Ground	CT	Oscillator Control	Gnd	Ground	FB	Voltage Feedback	Vcc	Power Supply	Comp.	Feedback Compensation	Enable	ON/OFF control
Name	Description																		
Output	PWM Output																		
P.Gnd	Power Ground																		
CT	Oscillator Control																		
Gnd	Ground																		
FB	Voltage Feedback																		
Vcc	Power Supply																		
Comp.	Feedback Compensation																		
Enable	ON/OFF control																		
<h3>Applications</h3> <ul style="list-style-type: none"> ◇ Charger ◇ xD-ROM, xDSL product ◇ DC to DC converter s 	<h3>Ordering Information</h3> <table border="1" style="width: 100%; border-collapse: collapse;"> <thead> <tr> <th style="text-align: center;">Part No.</th> <th style="text-align: center;">Operating Temp.</th> <th style="text-align: center;">Package</th> </tr> </thead> <tbody> <tr> <td style="text-align: center;">TS650CS</td> <td style="text-align: center;">-20 ~ +85 °C</td> <td style="text-align: center;">SOP-8</td> </tr> </tbody> </table>	Part No.	Operating Temp.	Package	TS650CS	-20 ~ +85 °C	SOP-8												
Part No.	Operating Temp.	Package																	
TS650CS	-20 ~ +85 °C	SOP-8																	
<h3>Block Diagram</h3> 																			

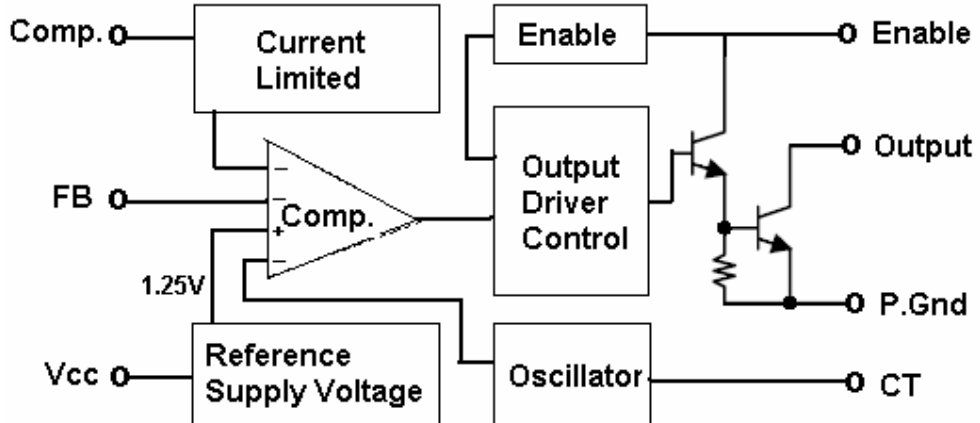

Absolute Maximum Rating			
Supply Voltage	V_{CC}	30	V
Comparator Input Voltage Range	V_{FB}	- 0.3 ~ 30	V
Collector Output Voltage	$V_{C(SW)}$	30	V
Collector to Emitter Voltage	$V_{CE(SW)}$	30	V
Output Switching Current	I_{SW}	500	mA
Operating Junction Temperature Range	T_J	-20 ~ +125	°C
Storage Temperature Range	T_{STG}	-65 ~ +150	°C
Lead Temperature 1.6mm(1/16") from case for 10Sec.	T_{LEAD}	260	°C

Electrical Characteristics						
(V _{CC} =5V, Ta =25 °C; unless otherwise specified.)						
Parameter	Symbol	Test Conditions	Min	Typ	Max	Unit
Reference						
Comp. Connect to FB	V_{REF}		1.23	1.25	1.27	V
Output voltage change with temperature		Ta= -20 °C ~ 25 °C		- 0.1	1	%
		Ta= 25 °C ~ 85 °C		- 0.2	1	
Line regulation	RegLine	V _{CC} = 5V ~ 30V			5	mV
Output switch (note1)						
Saturation Voltage	$V_{CE(SAT)}$	$I_{SW} = 0.5A$		1.0	1.2	V
DC current gain	H_{FE}	$I_{SW} = 1A, V_{ce} = 0.5V$		75		--
Collector off-state current	$I_{C(OFF)}$	V _{ce} =30V		40	100	uA
Oscillator (OSC)						
Frequency	F_{OSC}	C _T = 1nF, V _{pin5} =0V	24	33	42	KHz
Charge Current	I_{CHARGE}	V _{CC} = 5V ~ 30V		35		uA
Discharge Current	$I_{DISCHARGE}$	V _{CC} = 5V ~ 30V		220		uA
Discharge to Charge current ratio	$I_{DISCHARGE} / I_{CHARGE}$	Pin7 to V _{cc}		6.5		--
Current Limit Sense Voltage	$V_{IPK(SENSE)}$	$I_{DISCHARGE} = I_{CHARGE}$	250		350	mV
ON/OFF driver control						
ON driver voltage	V _{on}	V _{CC} = 3V ~ 30V	4		5	V
OFF driver voltage	V _{off}				1	V
ON driver current	I _{on}				100	mA
Total device						
supply current	I_{CC}	V _{CC} = 5V ~ 30V, C _T = 1nF, pin7=V _{cc} , pin5>V _{th} , pin2=Gnd, remaining pins open		3	5	mA
Input bias current	I_{IB}	V _{in} =0V			-400	nA

Note 1: Low duty cycle pulse techniques are used during test to maintain junction temperature as close to ambient temperature.

Typical Application Circuit

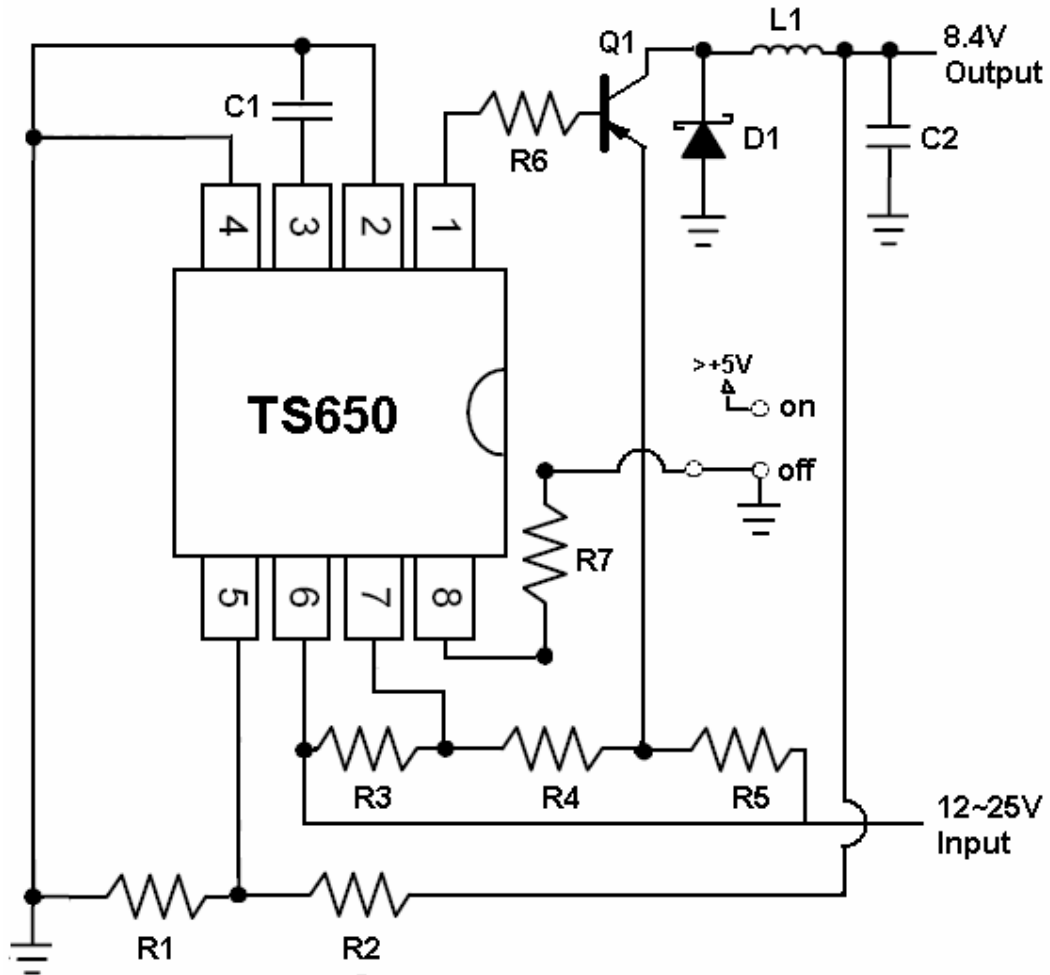

Device	Value	Device	Value
R1	5.6K, 1/8W	C1	470pF, 16V
R2	1K, 1/8W	C2	470uF, 16V
R3	100ohm, 1/4W	L1	180uH, 2A
R4	100ohm, 1/4W	D1	SK34A
R5	0.33ohm, 1W	Q1	TSB1386CY
R6	300ohm, 1/2W		
R7	300ohm, 1/2W		

Remark:

* Output = 1.25V * (R1/R2 + 1) = 1.25V * (5.6K/1K + 1) = 8.25V @ 3A

* SK34A: Taiwan semiconductor, Schottky 3A/40V in SMA package

* TSB1386CY: Taiwan semiconductor, PNP transistor 5A/20V in SOT-89 package

SOP-8 Mechanical Drawing

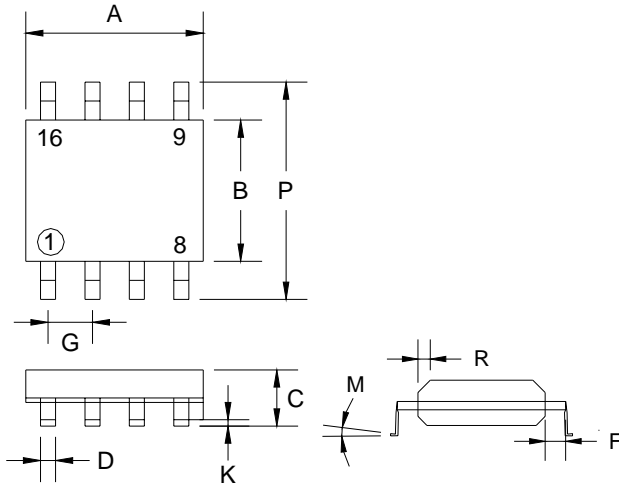

SOP-8 DIMENSION				
DIM	MILLIMETERS		INCHES	
	MIN	MAX	MIN	MAX
A	4.80	5.00	0.189	0.196
B	3.80	4.00	0.150	0.157
C	1.35	1.75	0.054	0.068
D	0.35	0.49	0.014	0.019
F	0.40	1.25	0.016	0.049
G	1.27 (typ)		0.05 (typ)	
K	0.10	0.25	0.004	0.009
M	0°	7°	0°	7°
P	5.80	6.20	0.229	0.244
R	0.25	0.50	0.010	0.019

Copyright © Each Manufacturing Company.

All Datasheets cannot be modified without permission.

This datasheet has been download from :

www.AllDataSheet.com

100% Free DataSheet Search Site.

Free Download.

No Register.

Fast Search System.

www.AllDataSheet.com