

INTEGRATED CIRCUITS

DATA SHEET

TSA5518M

1.3 GHz bidirectional I²C-bus
controlled synthesizer

Product specification
File under Integrated Circuits, IC02

1997 Mar 07

1.3 GHz bidirectional I²C-bus controlled synthesizer

TSA5518M

FEATURES

- Complete 1.3 GHz single chip system
- Low power 5 V, 40 mA
- I²C-bus programming
- One pin crystal oscillator
- In-lock flag
- Varicap drive disable
- Low radiation
- Address selection for picture in picture (PIP), DBS tuner, and so on
- 5-level A/D converter
- 7 bus-controlled ports (4 open-collector outputs and 3 emitter follower outputs), 1 bidirectional port
- Power-down flag
- Mixer/oscillator bandswitch output
- Available in SSOP20 package.

APPLICATIONS

- TV tuners and front-ends
- VCR tuners.



GENERAL DESCRIPTION

The device is a single chip PLL frequency synthesizer designed for TV tuning systems. Control data is entered via the I²C-bus; five serial bytes are required to address the device, select the oscillator frequency, program the 7 output ports and set the charge-pump current.

The output port P6 is combined with an A/D converter input. Digital information concerning this port can be read out of the SDA line (one status byte) during a READ operation. A flag is set when the loop is 'in-lock' and is read during a READ operation. The device has one fixed I²C-bus address, programmed by applying a specific voltage on AS input. The phase comparator operates at 7.8125 kHz when a 4 MHz crystal is used. The device provides a bandswitch output to select the bands of the mixer/oscillator ICs TDA5330, TDA5630A except TDA5630/C1 and TDA5730 with the appropriate voltage level.

QUICK REFERENCE DATA

SYMBOL	PARAMETER	CONDITIONS	MIN.	TYP.	MAX.	UNIT
V _{CC}	supply voltage		4.5	5	5.5	V
I _{CC}	supply current		–	40	–	mA
f _i	frequency		80	–	1300	MHz
V _{i(rms)}	input voltage level (RMS value)	80 to 150 MHz	12	–	300	mV
		150 MHz to 1.0 GHz	9	–	300	mV
		1 GHz to 1.3 GHz	40	–	300	mV
f _{xtal}	crystal oscillator frequency		3.2	4	4.48	MHz
I _o	output current	emitter follower on P4, P5 and P7	–	–	5	mA
		open-collector P0, P1 and P2	–	–	20	mA
		open-collector P6	–	–	10	mA
T _{amb}	operating ambient temperature		–10	–	+80	°C
R _{th j-a}	thermal resistance from junction to ambient		–	–	120	K/W

ORDERING INFORMATION

TYPE NUMBER	PACKAGE		
	NAME	DESCRIPTION	VERSION
TSA5518M	SSOP20	plastic shrink small outline package; 20 leads; body width 4.4 mm	SOT266-1

1.3 GHz bidirectional I²C-bus controlled synthesizer

TSA5518M

BLOCK DIAGRAM

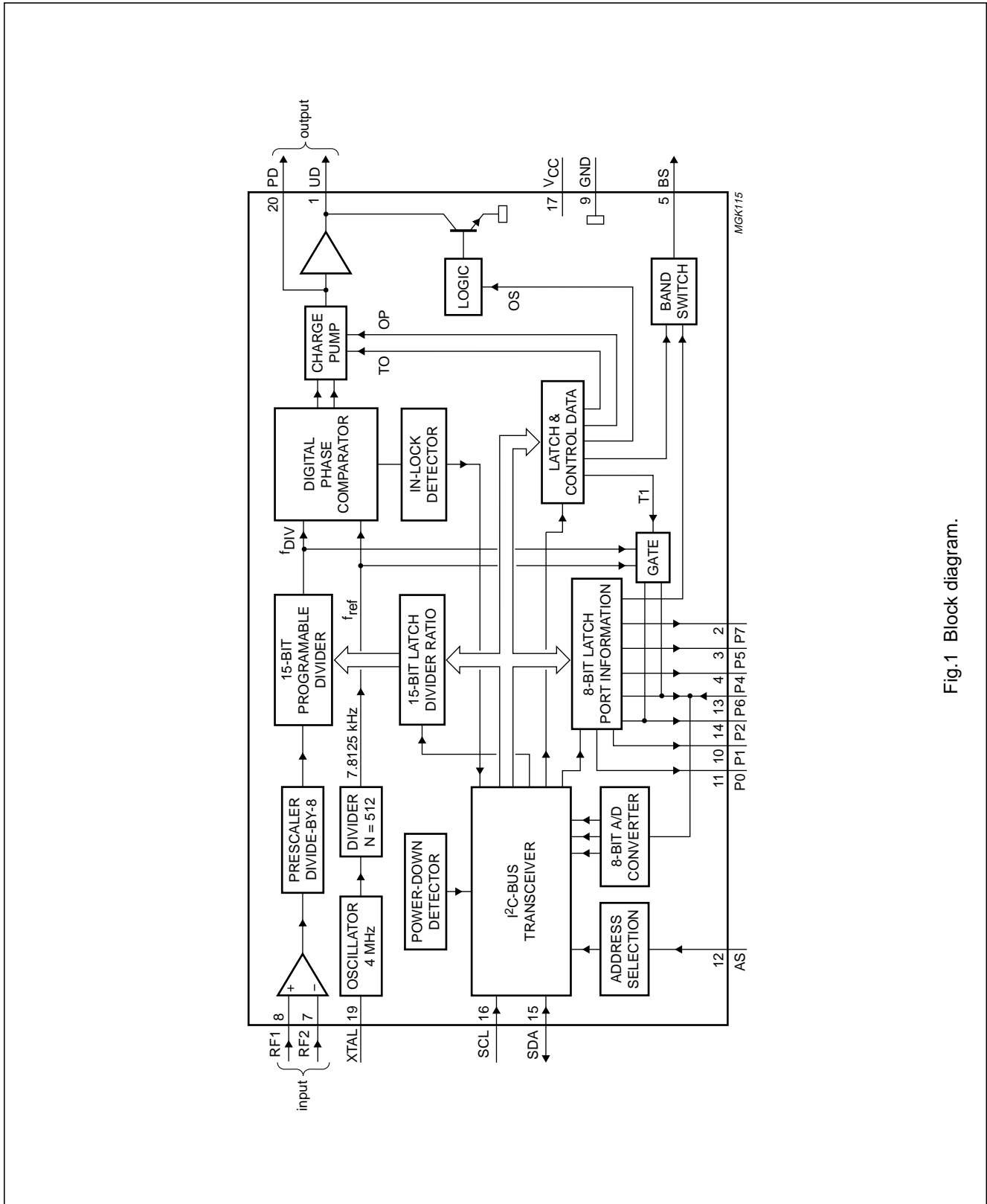

Fig.1 Block diagram.

1.3 GHz bidirectional I²C-bus controlled synthesizer

TSA5518M

PINNING

SYMBOL	PIN	DESCRIPTION
UD	1	drive output (UD)
P7	2	P7 output port
P5	3	P5 output port
P4	4	P4 output port
BS	5	bandswitch output for M/O drive
n.c.	6	not connected
RF2	7	UHF/VHF signal input 2
RF1	8	UHF/VHF signal input 1
GND	9	ground
P1	10	P1 output port (general purpose)
P0	11	P0 output port (general purpose)
AS	12	input for Address Selection
P6	13	P6 port (output/input for general purpose ADC)
P2	14	P2 output port (f_{DIV} if the test mode is active)
SDA	15	I ² C-bus serial data input/output
SCL	16	I ² C-bus serial clock
V _{CC}	17	voltage supply
n.c.	18	not connected
XTAL	19	crystal oscillator input
PD	20	charge-pump output (PD)

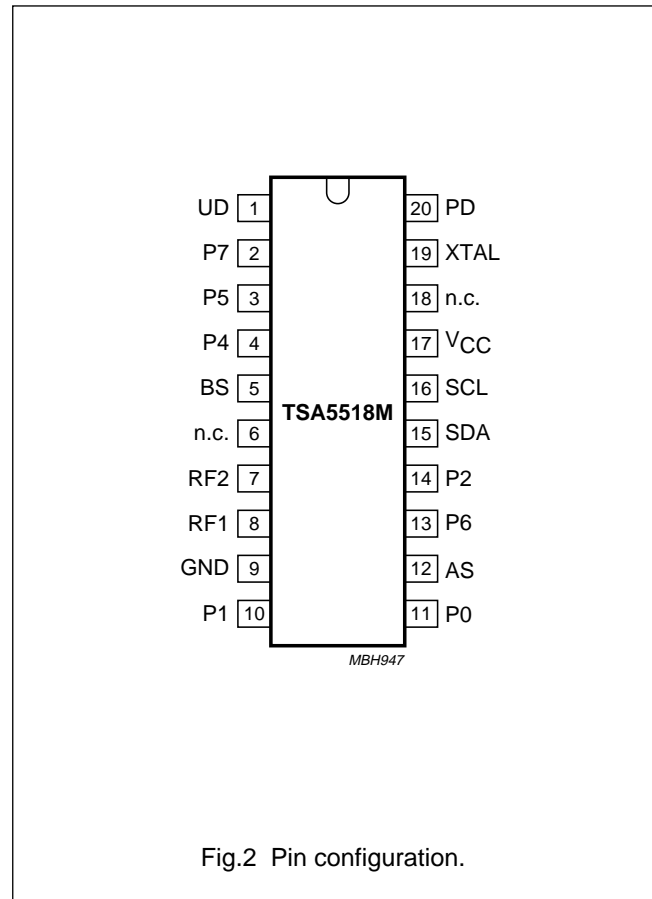

Fig.2 Pin configuration.

FUNCTIONAL DESCRIPTION

The device is controlled via the two wire I²C-bus. For programming, there is one module address (7 bits) and the R/W bit for selecting READ or WRITE mode.

Write mode

The write data format is summarized in Table 1. After the address transmission (first byte), data bytes can be sent to the device. Four data bytes are needed to fully program the device. The bus transceiver has an auto increment facility which permits the programming of the device within one single transmission (address byte + 4 data bytes). The device can also be partially programmed on the condition that the first data byte following the address is byte 2 or 4. The meaning of the bits in the data bytes is given in Table 3. The first bit of the first data byte transmitted indicates whether frequency data (first bit = 0)

or charge pump and port information (first bit = 1) will follow. Until an I²C-bus STOP condition is sent by the controller, additional data bytes can be entered without the need to re-address the device. This allows a smooth frequency sweep for fine tuning or AFC purpose. At power-on the ports are set to the high-impedance state (open-collector outputs) or at the HIGH level (emitter follower outputs). The bandswitch output BS provides a voltage output suitable for the band selection input of mixer/oscillator ICs TDA5330, TDA5630A and TDA5730. It is controlled by B1 and B0 bits or P7, P5 and P4 bits depending on the BSC bit (see Tables 1 to 4). The 7.8125 kHz reference frequency is obtained by dividing the output of the 4 MHz crystal oscillator by 512. Because the input of UHF/VHF signal is first divided-by-8 the step size is 62.5 kHz. A 3.2 MHz crystal can offer step size of 50 kHz.

1.3 GHz bidirectional I²C-bus controlled synthesizer

TSA5518M

Table 1 Write data format

BYTE	DESCRIPTION	MS B								LSB	ACKNOWLEDGE
		1	1	0	0	0	MA1	MA0	0		
1	address	1	1	0	0	0	MA1	MA0	0	LOW from device	
2	programmable divider	0	N14	N13	N12	N11	N10	N9	N8	LOW from device	
3	programmable divider	N7	N6	N5	N4	N3	N2	N1	N0	LOW from device	
4	charge-pump, bandswitch and test bits	1	CP	T1	T0	BSC	B1	B0	OS	LOW from device	
5	output ports control bits	P7	P6	P5	P4	X	P2	P1	P0	LOW from device	

Table 2 Explanation of Table 1

BIT	DESCRIPTION
MA1, MA0	programmable address bits (see Table 7)
N14, .. , N0	programmable divider bits $N = N14 \times 2^{14} + N13 \times 2^{13} + \dots + N1 \times 2^1 + N0$
CP	charge pump current CP = 0 to 50 μ A; CP = 1 to 220 μ A
T1, T0, OS	T1 = 0, T0 = 0, OS = 0: normal operation T1 = 1: P2 = f_{DIV} , P6 = f_{ref} T0 = 1: 3-state charge pump OS = 1: operational amplifier output is switched off (varicap drive disable)
BSC	bandswitch control bit BSC = 0: bandswitch output is controlled by B1 and B0 bits according to Table 3 BSC = 1: bandswitch output is controlled by P7, P5 and P4 bits according to Table 4
B1, B0	bandswitch control bits
P6, P2, P1 and P0	P6, P2 .. P0 = 1: open-collector outputs are active P6, P2 .. P0 = 0: outputs are in high impedance state
P4, P5 and P7	P4, P5 and P7 = 1: outputs are at low level P4, P5 and P7 = 0: emitter follower outputs are active
X	don't care

Table 3 BS output control (BSC = 0)

B1	B0	VOLTAGE ON PIN BS
0	0	0.25 V
0	1	2 V
1	0	4 V
1	1	V_{CC}

Table 4 BS output control (BSC = 1)

P7	P5	P4	VOLTAGE ON PIN BS
1	1	0	0.25 V
1	0	1	2 V
0	1	1	4 V

1.3 GHz bidirectional I²C-bus controlled synthesizer

TSA5518M

Read mode

The read data format is summarised in Table 5. Data can be read out of the device by setting the R/W bit to logic 1. After the slave address has been recognized, the device generates an acknowledge pulse and the status word is transferred on the SDA line (MSB first). Data is valid on the SDA line during a HIGH of the SCL clock signal. A second data byte can be read out of the device if the processor generates an acknowledge on the SDA line. End of transmission will occur if no acknowledge from the processor occurs. The device will then release the data line to allow the processor to generate a STOP condition. When the port P6 is used as input, it must be programmed

in its high-impedance state. The POR flag (Power-on reset) is set to logic 1 when V_{CC} goes below 3 V and at power-on. It is reset when an end of data is detected by the device (end of a READ sequence). Control of the loop is made possible with the in-lock flag FL which indicates (FL = 1) when the loop is phase-locked. A built-in % level A/D converter is available on I/O port P6. This converter can be used to feed AFC information to the controller from the IF section of the television as illustrated in the typical application circuit in Fig.2. The relationship between bit A2, A1 and A0 and the input voltage on port P6 is given in Table 6.

Table 5 Read data format

BYTE	DESCRIPTION	MSB							LSB		ACKNOWLEDGE
1	address	1	1	0	0	0	0	MA1 ⁽¹⁾	MA0 ⁽¹⁾	1	LOW from device
2, ..	status byte(s)	POR ⁽²⁾	FL ⁽³⁾	0	0	0	0	A2 ⁽⁴⁾	A1 ⁽⁴⁾	A0 ⁽⁴⁾	note 5

Notes

- See Table 7.
- POR: Power-on reset flag. (POR = 1 on power-on).
- FL: in lock flag (FL = 1 when the loop is phase-locked).
- A2, A1, A0: digital outputs of the 5 level A/D converter (see Table 6). Accuracy is 1/2 LSB. MSB is transmitted first.
- Upon an acknowledge pulse from the controller, the device transfers the status byte again. If no acknowledge pulse from the controller is received, data read is terminated.

Table 6 A/D converter levels

Accuracy on the switching levels is $\pm 0.02V_{CC}$.

VOLTAGE APPLIED ON PIN P6	A2	A1	A0
0.6V _{CC} to 5.5 V	1	0	0
0.45V _{CC} to 0.6V _{CC}	0	1	1
0.3V _{CC} to 0.45V _{CC}	0	1	0
0.15V _{CC} to 0.3V _{CC}	0	0	1
0 to 0.15V _{CC}	0	0	0

Table 7 Address selection

VOLTAGE APPLIED ON PIN AS	MA1	MA0
0 to 0.1V _{CC}	0	0
always valid	0	1
0.4 to 0.6V _{CC}	1	0
0.9V _{CC} to V _{CC}	1	1

Address selection

The module address contains programmable address bits (MA1 and MA0) which offer the possibility of having several synthesizers (up to 3) in one system by applying a specific voltage on AS input. The relationship between MA1 and MA0 and the input voltage on AS input is given in Table 7.

Frequency lock flag (FL) definition

When the FL flag is logic 1, the maximum frequency deviation dF from stable frequency can be expressed as:

$$df = \pm \frac{K_{VCO}}{K_O} \times I_{CP} \times \frac{C1 + C2}{C1 \times C2} \text{ with:}$$

K_{VCO} = oscillator slope (Hz/V)

I_{CP} = charge pump current (A)

K_O = 4×10^6

C1, C2 = loop filter capacitors.

1.3 GHz bidirectional I²C-bus controlled synthesizer

TSA5518M

LIMITING VALUES

Limiting values in accordance with the Absolute Maximum Rating System (IEC 134).

SYMBOL	PARAMETER	CONDITIONS	MIN.	MAX.	UNIT
V _{CC}	supply voltage		-0.3	+6	V
V _{i(XTAL)}	voltage at pin XTAL		-0.3	+V _{CC}	V
V _{i(SCL)}	voltage at pin SCL		-0.3	+6	V
V _{SDA}	voltage at pin SDA		-0.3	+6	V
V _{i(AS)}	voltage at pin AS		-0.3	+V _{CC}	V
V _{o(BS)}	voltage at pin BS		-0.3	+V _{CC}	V
V _{i(RF)}	voltage at pins RF1 and RF2		-0.3	+V _{CC}	V
V _o	output voltage at ports P0, P2 and P6		-0.3	+16	V
	output voltage at ports P4, P5 and P7		-0.3	+V _{CC}	V
V _{PD}	output voltage at pin PD		-0.3	+V _{CC}	V
V _{UD}	output voltage at pin UD		-0.3	+V _{CC}	V
I _{SDA}	output current at pin SDA	open collector	-1	+5	mA
I _o	output current at pins P0, P1 and P2		-1	+20	mA
	output current at pins P4, P5 and P7	emitter follower	-1	+10	mA
	output current at pin P6	open collector	-1	+10	mA
T _{stg}	storage temperature		-40	+150	°C
T _{j(max)}	maximum junction temperature		-	150	°C
t _{sc(GND)(max)}	maximum short circuit time to GND	one pin to GND (V _{CC} = 5.5 V; GND = 0 V)	-	10	s
t _{sc(VCC)(max)}	maximum short circuit time to V _{CC}	one pin to V _{CC} (V _{CC} = 5.5 V; GND = 0 V)	-	10	s

HANDLING

Every pin withstands the ESD test in accordance with MIL-STD-883C category B (2000 V).

Every pin withstands the ESD test in accordance with Philips Semiconductor machine model 0 Ω, 200 pF.

THERMAL CHARACTERISTICS

SYMBOL	PARAMETER	CONDITIONS	VALUE	UNIT
R _{th j-a}	thermal resistance from junction to ambient	in free air	120	K/W

1.3 GHz bidirectional I²C-bus controlled synthesizer

TSA5518M

CHARACTERISTICS

$V_{CC} = 4.5$ to 5.5 V; $T_{amb} = -10$ to $+80$ °C; unless otherwise specified.

SYMBOL	PARAMETER	CONDITIONS	MIN.	TYP.	MAX.	UNIT
Operating characteristics						
V_{CC}	supply voltage		4.5	–	5.5	V
T_{amb}	operating ambient temperature		–10	–	+80	°C
f_i	input frequency		80	–	1300	MHz
N	divider	note 1	256	–	32767	
I_{CC}	supply current		25	40	50	mA
Crystal oscillator						
f_{osc}	oscillator frequency		3.2	4	4.48	MHz
$Z_{i(XTAL)}$	input impedance on pin XTAL		–	–	–450	Ω
$V_{o(XTAL)}$	output drive level on pin XTAL		–	40	–	mV
$V_{i(RF)}$	input level	see Fig.3 $f_i = 80$ to 150 MHz $f_i = 150$ to 1000 MHz $f_i = 1000$ to 1300 MHz	12	–	300	mV
			9	–	300	mV
			40	–	300	mV
			–	–	10	mV
	flatness of the minimum sensitivity		150	–	1000	MHz
	prescaler input impedance		see Fig.4			
Output port P0, P1 and P2 (open collector); note 1						
I_{LO}	output leakage current	$V_{Pn} = 13.5$ V	–	–	10	μ A
$I_{o(sink)}$	output sink current	note 2	–	–	20	mA
V_{OL}	LOW-level output voltage	$I_{Pn} = 15$ mA	–	–	0.5	V
$C_{L(max)}$	maximum capacitive loading on output pin	$V_{Pn} = 5.5$ V	–	–	100	nF
Output ports P4, P5 and P7 (emitter follower)						
V_{OH}	HIGH-level output voltage	$I_{port} = 3$ mA	$V_{CC} - 1$	–	–	V
I_{OH}	HIGH-level output current		–	3	5	mA
Output port P6 (open collector)						
I_{LO}	output leakage current	$V_{P6} = 13.5$ V	–	1	10	μ A
$I_{o(sink)}$	output sink current	note 2	–	–	10	mA
V_{OL}	LOW-level output voltage	$I_{P6} = 5$ mA	–	–	0.4	V
$C_{L(max)}$	maximum capacitive loading on output pin	$V_{P6} = 5.5$ V	–	–	100	nF
Input port AS						
I_{IH}	HIGH-level input current	$V_{ASH} = V_{CC}$	–	–	10	μ A
I_{IL}	HIGH-level input current	$V_{ASL} = 0$ V	–10	–	–	μ A
Input port P6						
I_{IH}	HIGH-level input current	$V_{P6H} = 5.5$ V	–	–	10	μ A
I_{IL}	LOW-level input current	$V_{P6L} = 0$ V	–10	–	–	μ A

1.3 GHz bidirectional I²C-bus controlled synthesizer

TSA5518M

SYMBOL	PARAMETER	CONDITIONS	MIN.	TYP.	MAX.	UNIT
Bandswitch output BS						
V _{O(BSA)}	output voltage for band A	I _{source(BSA)} = 20 μA	–	0.25	0.5	V
V _{O(BSB)}	output voltage for band B	I _{source(BSB)} = 20 μA; note 3	0.36 V _{CC}	0.4 V _{CC}	0.43 V _{CC}	V
V _{O(BSC)}	output voltage for band C	I _{source(BSC)} = 20 μA; note 3	0.7 V _{CC}	0.8 V _{CC}	0.9 V _{CC}	V
I²C-bus inputs SCL, SDA; note 4						
V _{IH}	HIGH-level input voltage		3	–	5.5	V
V _{IL}	LOW-level input voltage		–	–	1.5	V
hys _i	input hysteresis	V _{CC} = 5 V	–	250	–	mV
I _{IH}	HIGH-level input current	V _{BH} = 5.5 V; V _{CC} = 0 V	–	–	10	μA
		V _{BH} = 5.5 V; V _{CC} = 5.5 V	–	–	10	μA
I _{IL}	LOW-level input current	V _{BL} = 0 V; V _{CC} = 0 V	–10	–	–	μA
		V _{BL} = 0 V; V _{CC} = 5.5 V	–10	–	–	μA
Output SDA (open collector)						
I _{LO}	output leakage current	V _{SDAH} = V _{CC}	–	–	10	μA
V _O	output voltage	I _{SDAL} = 3 mA	–	–	0.4	V
Charge-pump output PD						
I _{OH(cp)}	HIGH level output charge pump current	CP = 1	140	220	300	μA
I _{OL(cp)}	LOW level output charge pump current	CP = 0	25	50	75	μA
V _O	output voltage	in-lock	1.5	–	2.5	V
I _{LZ}	OFF-state leakage current	T ₀ = 1	–5	–	+5	nA
Operational amplifier output UD (test mode: T₀ = 1)						
V _{O(off)}	output voltage when switched-off	OS = 1; I _{UD} = 1 mA	–	–	200	mV
V _{O(loop)}	output voltage when the loop is closed	OS = 0; T ₀ = 0	–	–	1.2	V

Notes

1. If the dividing number N is set to less than 256, a dividing number of 256 is used.
2. When a port is active, the collector voltage may not exceed 6 V.
3. Measured with all other ports active at max. current (10 mA or 20 mA respectively).
4. See "The I²C-bus and how to use it", order no. 9398 393 40011.

1.3 GHz bidirectional I²C-bus controlled synthesizer

TSA5518M

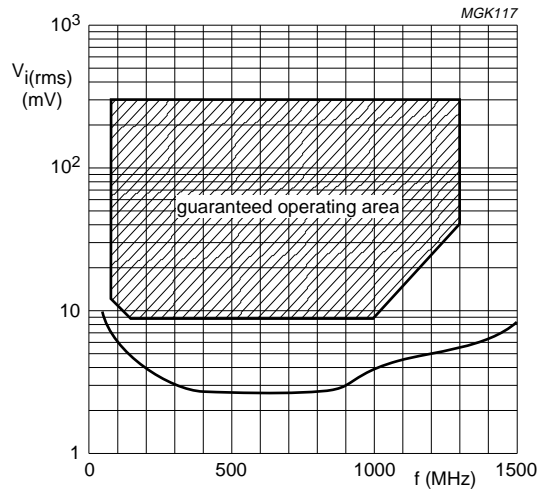

Fig.3 I/O prescaler typical input sensitivity curve: $V_{CC} = 4.5$ to 5.5 V; $T_{amb} = -10$ to $+80$ °C.

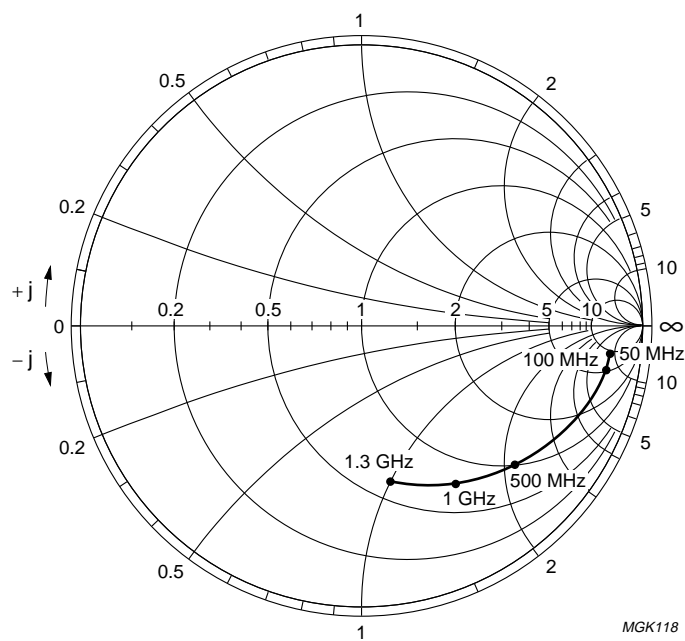

Fig.4 Prescaler Smith-chart of typical input impedance: $V_{CC} = 5$ V; reference value 50Ω .

1.3 GHz bidirectional I²C-bus controlled synthesizer

TSA5518M

INTERNAL PIN CONFIGURATION

PIN	CONFIGURATION	PIN	CONFIGURATION
1 and 20		7 and 8	
2, 3 and 4		10, 11, 13 and 14	
5		12	
		15	

1.3 GHz bidirectional I²C-bus controlled synthesizer

TSA5518M

PIN	CONFIGURATION
16	

PIN	CONFIGURATION
19	

1.3 GHz bidirectional I²C-bus controlled synthesizer

TSA5518M

APPLICATION INFORMATION

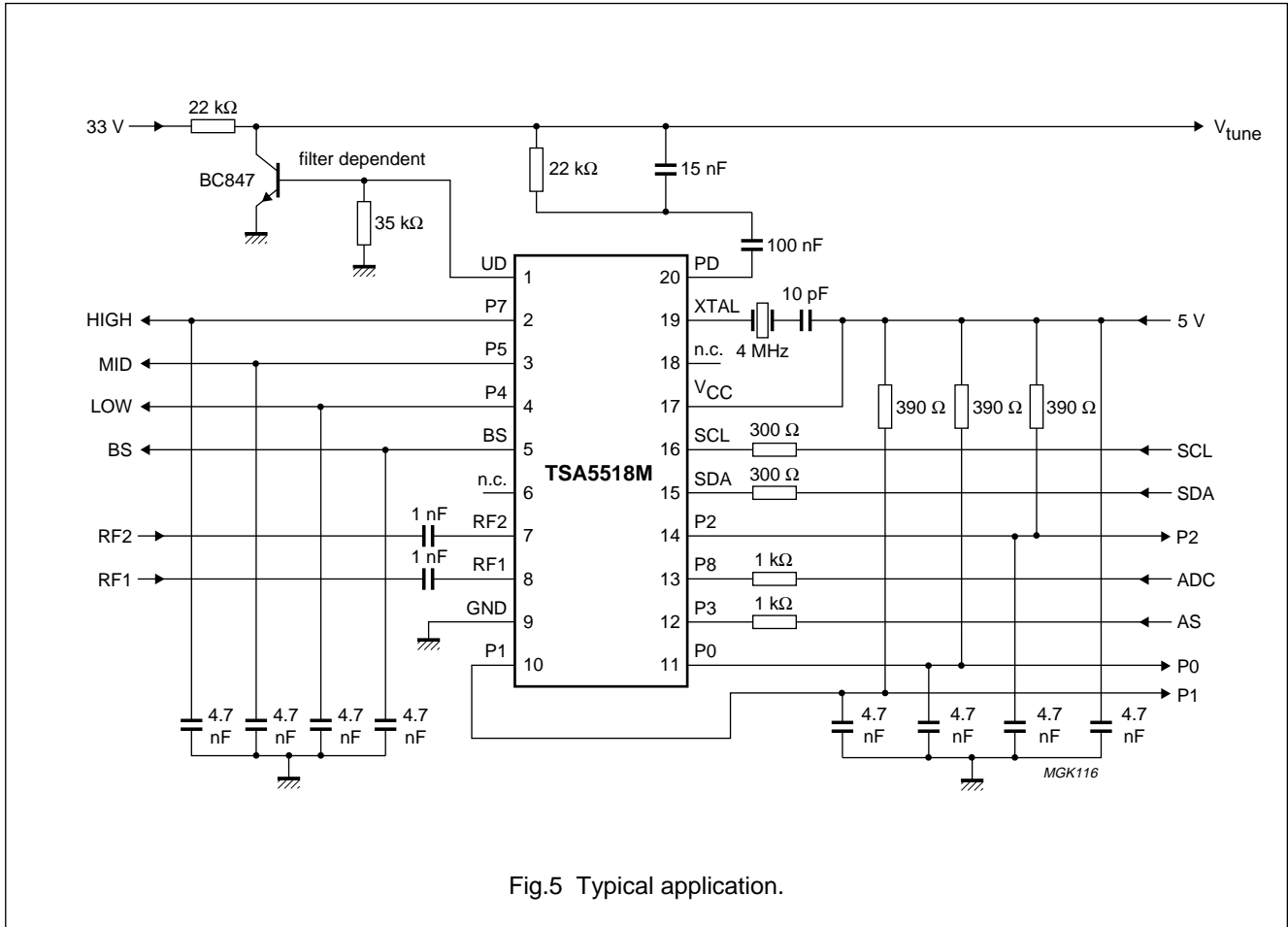

Loop filter

Table 8 Loop filter

DESCRIPTION	MIN.	MAX.	UNIT
Time span between actual phase lock and FL flag setting	1024	1152	μs
Time span between the loop losing lock and FL flag resetting	0	128	μs

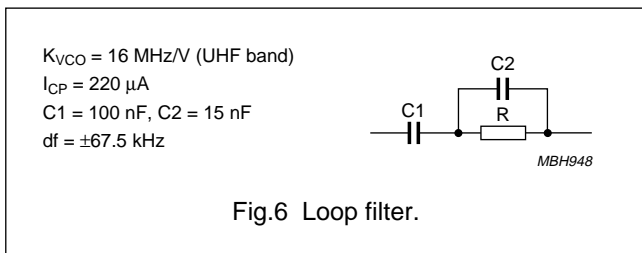

1.3 GHz bidirectional I²C-bus controlled synthesizer

TSA5518M

PACKAGE OUTLINE

SSOP20: plastic shrink small outline package; 20 leads; body width 4.4 mm

SOT266-1

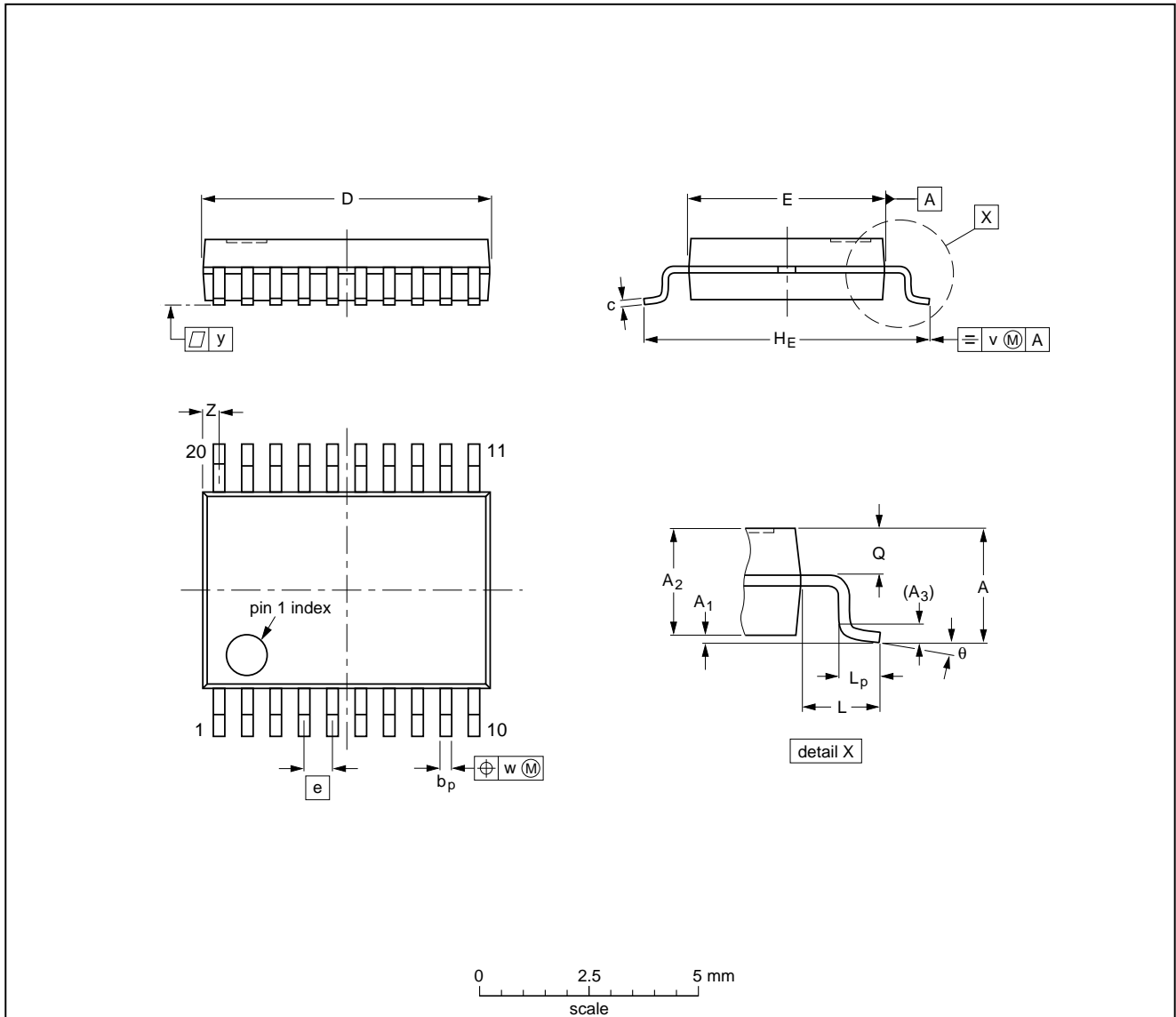

DIMENSIONS (mm are the original dimensions)

UNIT	A max.	A ₁	A ₂	A ₃	b _p	c	D ⁽¹⁾	E ⁽¹⁾	e	H _E	L	L _p	Q	v	w	y	Z ⁽¹⁾	θ
mm	1.5	0.15 0	1.4 1.2	0.25	0.32 0.20	0.20 0.13	6.6 6.4	4.5 4.3	0.65	6.6 6.2	1.0	0.75 0.45	0.65 0.45	0.2	0.13	0.1	0.48 0.18	10° 0°

Note

1. Plastic or metal protrusions of 0.20 mm maximum per side are not included.

OUTLINE VERSION	REFERENCES				EUROPEAN PROJECTION	ISSUE DATE
	IEC	JEDEC	EIAJ			
SOT266-1						90-04-05 95-02-25

1.3 GHz bidirectional I²C-bus controlled synthesizer

TSA5518M

SOLDERING

Introduction

There is no soldering method that is ideal for all IC packages. Wave soldering is often preferred when through-hole and surface mounted components are mixed on one printed-circuit board. However, wave soldering is not always suitable for surface mounted ICs, or for printed-circuits with high population densities. In these situations reflow soldering is often used.

This text gives a very brief insight to a complex technology. A more in-depth account of soldering ICs can be found in our *"IC Package Databook"* (order code 9398 652 90011).

Reflow soldering

Reflow soldering techniques are suitable for all SSOP packages.

Reflow soldering requires solder paste (a suspension of fine solder particles, flux and binding agent) to be applied to the printed-circuit board by screen printing, stencilling or pressure-syringe dispensing before package placement.

Several techniques exist for reflowing; for example, thermal conduction by heated belt. Dwell times vary between 50 and 300 seconds depending on heating method. Typical reflow temperatures range from 215 to 250 °C.

Preheating is necessary to dry the paste and evaporate the binding agent. Preheating duration: 45 minutes at 45 °C.

Wave soldering

Wave soldering is **not** recommended for SSOP packages. This is because of the likelihood of solder bridging due to closely-spaced leads and the possibility of incomplete solder penetration in multi-lead devices.

If wave soldering cannot be avoided, the following conditions must be observed:

- **A double-wave (a turbulent wave with high upward pressure followed by a smooth laminar wave) soldering technique should be used.**
- **The longitudinal axis of the package footprint must be parallel to the solder flow and must incorporate solder thieves at the downstream end.**

Even with these conditions, only consider wave soldering SSOP packages that have a body width of 4.4 mm, that is SSOP16 (SOT369-1) or SSOP20 (SOT266-1).

During placement and before soldering, the package must be fixed with a droplet of adhesive. The adhesive can be applied by screen printing, pin transfer or syringe dispensing. The package can be soldered after the adhesive is cured.

Maximum permissible solder temperature is 260 °C, and maximum duration of package immersion in solder is 10 seconds, if cooled to less than 150 °C within 6 seconds. Typical dwell time is 4 seconds at 250 °C.

A mildly-activated flux will eliminate the need for removal of corrosive residues in most applications.

Repairing soldered joints

Fix the component by first soldering two diagonally-opposite end leads. Use only a low voltage soldering iron (less than 24 V) applied to the flat part of the lead. Contact time must be limited to 10 seconds at up to 300 °C. When using a dedicated tool, all other leads can be soldered in one operation within 2 to 5 seconds between 270 and 320 °C.

1.3 GHz bidirectional I²C-bus controlled synthesizer

TSA5518M

DEFINITIONS

Data sheet status	
Objective specification	This data sheet contains target or goal specifications for product development.
Preliminary specification	This data sheet contains preliminary data; supplementary data may be published later.
Product specification	This data sheet contains final product specifications.
Limiting values	
Limiting values given are in accordance with the Absolute Maximum Rating System (IEC 134). Stress above one or more of the limiting values may cause permanent damage to the device. These are stress ratings only and operation of the device at these or at any other conditions above those given in the Characteristics sections of the specification is not implied. Exposure to limiting values for extended periods may affect device reliability.	
Application information	
Where application information is given, it is advisory and does not form part of the specification.	

LIFE SUPPORT APPLICATIONS

These products are not designed for use in life support appliances, devices, or systems where malfunction of these products can reasonably be expected to result in personal injury. Philips customers using or selling these products for use in such applications do so at their own risk and agree to fully indemnify Philips for any damages resulting from such improper use or sale.

PURCHASE OF PHILIPS I²C COMPONENTS



Purchase of Philips I²C components conveys a license under the Philips' I²C patent to use the components in the I²C system provided the system conforms to the I²C specification defined by Philips. This specification can be ordered using the code 9398 393 40011.

1.3 GHz bidirectional I²C-bus controlled
synthesizer

TSA5518M

NOTES

1.3 GHz bidirectional I²C-bus controlled
synthesizer

TSA5518M

NOTES

1.3 GHz bidirectional I²C-bus controlled
synthesizer

TSA5518M

NOTES

Philips Semiconductors – a worldwide company

Argentina: see South America

Australia: 34 Waterloo Road, NORTH RYDE, NSW 2113,
Tel. +61 2 9805 4455, Fax. +61 2 9805 4466

Austria: Computerstr. 6, A-1101 WIEN, P.O. Box 213,
Tel. +43 1 60 101, Fax. +43 1 60 101 1210

Belarus: Hotel Minsk Business Center, Bld. 3, r. 1211, Volodarski Str. 6,
220050 MINSK, Tel. +375 172 200 733, Fax. +375 172 200 773

Belgium: see The Netherlands

Brazil: see South America

Bulgaria: Philips Bulgaria Ltd., Energoproject, 15th floor,
51 James Bourchier Blvd., 1407 SOFIA,
Tel. +359 2 689 211, Fax. +359 2 689 102

Canada: PHILIPS SEMICONDUCTORS/COMPONENTS,
Tel. +1 800 234 7381

China/Hong Kong: 501 Hong Kong Industrial Technology Centre,
72 Tat Chee Avenue, Kowloon Tong, HONG KONG,
Tel. +852 2319 7888, Fax. +852 2319 7700

Colombia: see South America

Czech Republic: see Austria

Denmark: Prags Boulevard 80, PB 1919, DK-2300 COPENHAGEN S,
Tel. +45 32 88 2636, Fax. +45 31 57 1949

Finland: Sinikalliontie 3, FIN-02630 ESPOO,
Tel. +358 9 615800, Fax. +358 9 61580/xxx

France: 4 Rue du Port-aux-Vins, BP317, 92156 SURESNES Cedex,
Tel. +33 1 40 99 6161, Fax. +33 1 40 99 6427

Germany: Hammerbrookstraße 69, D-20097 HAMBURG,
Tel. +49 40 23 53 60, Fax. +49 40 23 536 300

Greece: No. 15, 25th March Street, GR 17778 TAVROS/ATHENS,
Tel. +30 1 4894 339/239, Fax. +30 1 4814 240

Hungary: see Austria

India: Philips INDIA Ltd, Shivsagar Estate, A Block, Dr. Annie Besant Rd.
Worli, MUMBAI 400 018, Tel. +91 22 4938 541, Fax. +91 22 4938 722

Indonesia: see Singapore

Ireland: Newstead, Clonskeagh, DUBLIN 14,
Tel. +353 1 7640 000, Fax. +353 1 7640 200

Israel: RAPAC Electronics, 7 Kehilat Saloniki St, TEL AVIV 61180,
Tel. +972 3 645 0444, Fax. +972 3 649 1007

Italy: PHILIPS SEMICONDUCTORS, Piazza IV Novembre 3,
20124 MILANO, Tel. +39 2 6752 2531, Fax. +39 2 6752 2557

Japan: Philips Bldg 13-37, Kohnan 2-chome, Minato-ku, TOKYO 108,
Tel. +81 3 3740 5130, Fax. +81 3 3740 5077

Korea: Philips House, 260-199 Itaewon-dong, Yongsan-ku, SEOUL,
Tel. +82 2 709 1412, Fax. +82 2 709 1415

Malaysia: No. 76 Jalan Universiti, 46200 PETALING JAYA, SELANGOR,
Tel. +60 3 750 5214, Fax. +60 3 757 4880

Mexico: 5900 Gateway East, Suite 200, EL PASO, TEXAS 79905,
Tel. +9-5 800 234 7381

Middle East: see Italy

Netherlands: Postbus 90050, 5600 PB EINDHOVEN, Bldg. VB,
Tel. +31 40 27 82785, Fax. +31 40 27 88399

New Zealand: 2 Wagener Place, C.P.O. Box 1041, AUCKLAND,
Tel. +64 9 849 4160, Fax. +64 9 849 7811

Norway: Box 1, Manglerud 0612, OSLO,
Tel. +47 22 74 8000, Fax. +47 22 74 8341

Philippines: Philips Semiconductors Philippines Inc.,
106 Valero St. Salcedo Village, P.O. Box 2108 MCC, MAKATI,
Metro MANILA, Tel. +63 2 816 6380, Fax. +63 2 817 3474

Poland: Ul. Lukiska 10, PL 04-123 WARSZAWA,
Tel. +48 22 612 2831, Fax. +48 22 612 2327

Portugal: see Spain

Romania: see Italy

Russia: Philips Russia, Ul. Usatcheva 35A, 119048 MOSCOW,
Tel. +7 095 755 6918, Fax. +7 095 755 6919

Singapore: Lorong 1, Toa Payoh, SINGAPORE 1231,
Tel. +65 350 2538, Fax. +65 251 6500

Slovakia: see Austria

Slovenia: see Italy

South Africa: S.A. PHILIPS Pty Ltd., 195-215 Main Road Martindale,
2092 JOHANNESBURG, P.O. Box 7430 Johannesburg 2000,
Tel. +27 11 470 5911, Fax. +27 11 470 5494

South America: Rua do Rocio 220, 5th floor, Suite 51,
04552-903 São Paulo, SÃO PAULO - SP, Brazil,
Tel. +55 11 821 2333, Fax. +55 11 829 1849

Spain: Balmes 22, 08007 BARCELONA,
Tel. +34 3 301 6312, Fax. +34 3 301 4107

Sweden: Kottbygatan 7, Akalla, S-16485 STOCKHOLM,
Tel. +46 8 632 2000, Fax. +46 8 632 2745

Switzerland: Allmendstrasse 140, CH-8027 ZÜRICH,
Tel. +41 1 488 2686, Fax. +41 1 481 7730

Taiwan: Philips Semiconductors, 6F, No. 96, Chien Kuo N. Rd., Sec. 1,
TAIPEI, Taiwan Tel. +886 2 2134 2870, Fax. +886 2 2134 2874

Thailand: PHILIPS ELECTRONICS (THAILAND) Ltd.,
209/2 Sanpavuth-Bangna Road Prakanong, BANGKOK 10260,
Tel. +66 2 745 4090, Fax. +66 2 398 0793

Turkey: Talatpasa Cad. No. 5, 80640 GÜLTEPE/ISTANBUL,
Tel. +90 212 279 2770, Fax. +90 212 282 6707

Ukraine: PHILIPS UKRAINE, 4 Patrice Lumumba str., Building B, Floor 7,
252042 KIEV, Tel. +380 44 264 2776, Fax. +380 44 268 0461

United Kingdom: Philips Semiconductors Ltd., 276 Bath Road, Hayes,
MIDDLESEX UB3 5BX, Tel. +44 181 730 5000, Fax. +44 181 754 8421

United States: 811 East Arques Avenue, SUNNYVALE, CA 94088-3409,
Tel. +1 800 234 7381

Uruguay: see South America

Vietnam: see Singapore

Yugoslavia: PHILIPS, Trg N. Pasica 5/v, 11000 BEOGRAD,
Tel. +381 11 625 344, Fax. +381 11 635 777

For all other countries apply to: Philips Semiconductors, Marketing & Sales Communications,
Building BE-p, P.O. Box 218, 5600 MD EINDHOVEN, The Netherlands, Fax. +31 40 27 24825

Internet: <http://www.semiconductors.philips.com>

© Philips Electronics N.V. 1997

SCA53

All rights are reserved. Reproduction in whole or in part is prohibited without the prior written consent of the copyright owner.

The information presented in this document does not form part of any quotation or contract, is believed to be accurate and reliable and may be changed without notice. No liability will be accepted by the publisher for any consequence of its use. Publication thereof does not convey nor imply any license under patent- or other industrial or intellectual property rights.

Printed in The Netherlands

547047/1200/01/pp20

Date of release: 1997 Mar 07

Document order number: 9397 750 01612

Let's make things better.