

INTEGRATED CIRCUITS

DATA SHEET

TZA3023 **SDH/SONET STM4/OC12** **transimpedance amplifier**

Product specification
Supersedes data of 1997 Oct 17
File under Integrated Circuits, IC19

2000 Mar 29

SDH/SONET STM4/OC12 transimpedance amplifier

TZA3023

FEATURES

- Wide dynamic input range from 1 μ A to 1.5 mA
- Low equivalent input noise of 3.5 $\text{pA}/\sqrt{\text{Hz}}$ (typical)
- Differential transimpedance of 21 $\text{k}\Omega$
- Wide bandwidth from DC to 600 MHz
- Differential outputs
- On-chip Automatic Gain Control (AGC)
- No external components required
- Single supply voltage from 3.0 to 5.5 V
- Bias voltage for PIN diode
- Pin compatible with SA5223.

APPLICATIONS

- Digital fibre optic receiver in short, medium and long haul optical telecommunications transmission systems or in high-speed data networks
- Wideband RF gain block.

DESCRIPTION

The TZA3023 is a low-noise transimpedance amplifier with AGC designed to be used in STM4/OC12 fibre optic links. It amplifies the current generated by a photo detector (PIN diode or avalanche photodiode) and converts it to a differential output voltage.

ORDERING INFORMATION

TYPE NUMBER	PACKAGE		
	NAME	DESCRIPTION	VERSION
TZA3023T	SO8	plastic small outline package; 8 leads; body width 3.9 mm	SOT96-1
TZA3023U	–	bare die in wafer pack carriers; die dimensions 1.030 \times 1.300 mm	–

BLOCK DIAGRAM

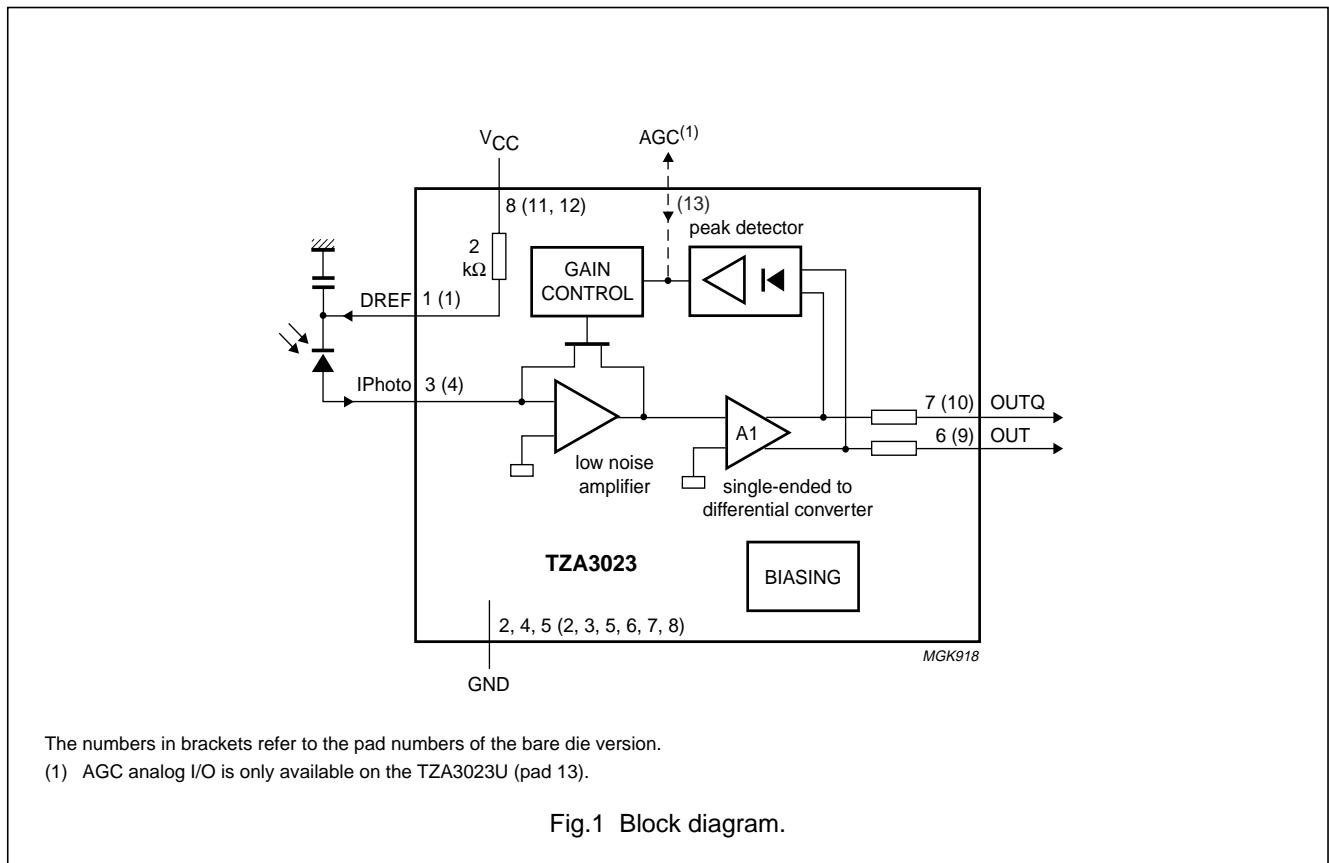

**SDH/SONET STM4/OC12
transimpedance amplifier**

TZA3023

PINNING

SYMBOL	PIN TZA3023T	PAD TZA3023U	TYPE	DESCRIPTION
DREF	1	1	analog output	bias voltage for PIN diode; cathode should be connected to this pin
GND	2	2, 3	ground	ground
IPhoto	3	4	analog input	current input; anode of PIN diode should be connected to this pin; DC bias level of 800 mV, one diode voltage above ground
GND	4	5, 6	ground	ground
GND	5	7, 8	ground	ground
OUT	6	9	output	data output; pin OUT goes HIGH when current flows into pin IPhoto
OUTQ	7	10	output	data output; compliment of pin OUT
V _{CC}	8	11, 12	supply	supply voltage
AGC	–	13	input/output	AGC analog I/O

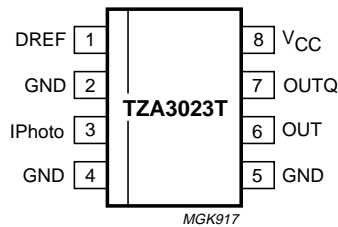

Fig.2 Pin configuration.

**SDH/SONET STM4/OC12
transimpedance amplifier**

TZA3023

FUNCTIONAL DESCRIPTION

The TZA3023 is a transimpedance amplifier intended for use in fibre optic links for signal recovery in STM4/OC12 applications. It amplifies the current generated by a photo detector (PIN diode or avalanche photodiode) and transforms it into a differential output voltage. The most important characteristics of the TZA3023 are high receiver sensitivity and wide dynamic range.

High receiver sensitivity is achieved by minimizing noise in the transimpedance amplifier. The signal current generated by a PIN diode can vary between 1 μ A to 1.5 mA (p-p). An AGC loop is implemented to make it possible to handle such a wide dynamic range. The AGC loop increases the dynamic range of the receiver by reducing the feedback resistance of the preamplifier.

The AGC loop hold capacitor is integrated on-chip, so an external capacitor is not needed for AGC. The AGC voltage can be monitored at pad 13 on the bare die (TZA3023U). Pad 13 is not bonded in the packaged device (TZA3023T). This pad can be left unconnected during normal operation. It can also be used to force an external AGC voltage. If pad 13 is connected to GND, the internal AGC loop is disabled and the receiver gain is at a maximum. The maximum input current is then approximately 50 μ A.

A differential amplifier converts the single-ended output of the preamplifier to a differential output voltage (see Fig.3).

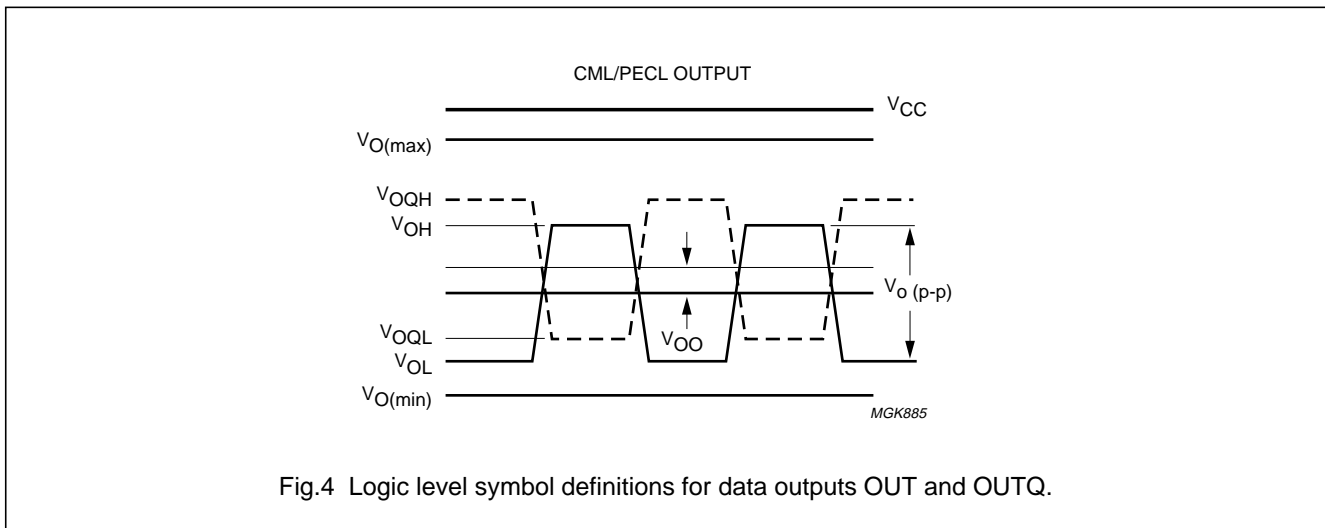
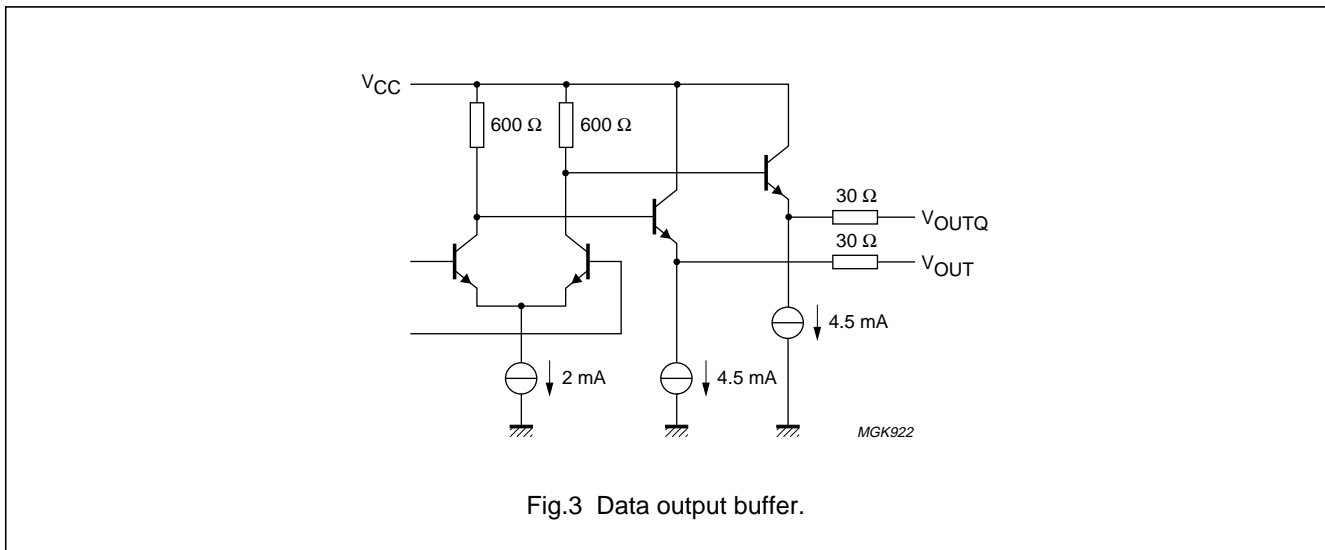

SDH/SONET STM4/OC12
transimpedance amplifier

TZA3023

PIN diode bias voltage DREF

The transimpedance amplifier together with the PIN diode determines the performance of an optical receiver for a large extent. Especially how the PIN diode is connected to the input and the layout around the input pin influence the key parameters like sensitivity, bandwidth and the Power Supply Rejection Ratio (PSRR) of a transimpedance amplifier. The total capacitance at the input pin is critical to obtain the highest sensitivity. It should be kept to a minimum by reducing the capacitor of the PIN diode and the parasitics around the input pin. The PIN diode should be placed very close to the IC to reduce the parasitics. Because the capacitance of the PIN diode depends on the reverse voltage across it, the reverse voltage should be chosen as high as possible.

The PIN diode can be connected to the input in two ways as shown in Figs 5 and 6. In Fig.5 the PIN diode is connected between DREF and IPhoto. Pin DREF provides an easy bias voltage for the PIN diode. The voltage at DREF is derived from V_{CC} by a low-pass filter. The low-pass filter consisting of the internal resistor R1, C1 and the external capacitor C2 rejects the supply voltage noise. The external capacitor C2 should be equal or larger then 1 nF for a high PSRR.

The reverse voltage across the PIN diode is 4.2 V (5 – 0.8 V) for 5 V supply or 2.5 V (3.3 – 0.8 V) for 3.3 V supply.

The DC voltage at DREF decreases with increasing signal levels. Consequently the reverse voltage across the PIN diode will also decrease with increasing signal levels. This can be explained with an example. When the PIN diode delivers a peak-to-peak current of 1 mA, the average DC current will be 0.5 mA. This DC current is delivered by V_{CC} through the internal resistor R1 of 2 k Ω which will cause a voltage drop of 1 V across the resistor and the reverse voltage across the PIN diode will be reduced by 1 V.

It is preferable to connect the cathode of the PIN diode to a higher voltage then V_{CC} when such a voltage source is available on the board. In this case pin DREF can be left unconnected. When a negative supply voltage is available, the configuration in Fig.6 can be used. It should be noted that in this case the direction of the signal current is reversed compared to Fig.5. Proper filtering of the bias voltage for the PIN diode is essential to achieve the highest sensitivity level.

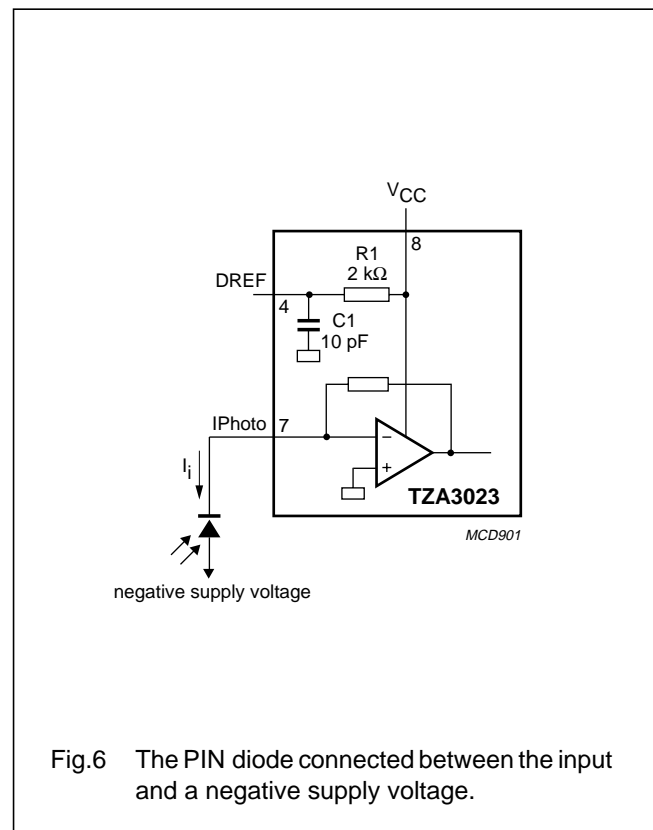
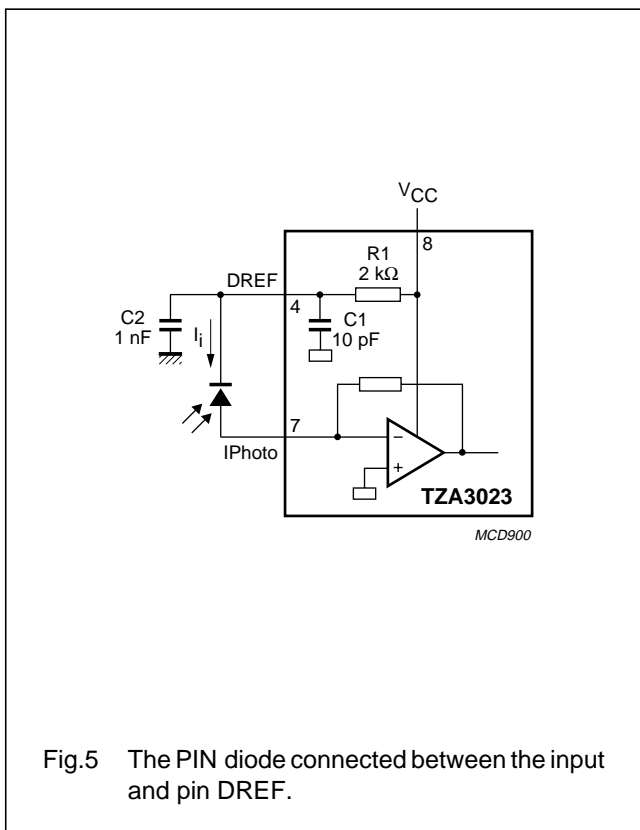

SDH/SONET STM4/OC12
transimpedance amplifier

TZA3023

AGC

TZA3023 transimpedance amplifier can handle input currents from 0.5 μA to 1.5 mA. This means a dynamic range of 72 dB. At low input currents, the transimpedance must be high to get enough output voltage, and the noise should be low enough to guaranty minimum bit error rate. At high input currents however, the transimpedance should be low to avoid pulse width distortion. This means that the gain of the amplifier has to vary depending on the input signal level to handle such a wide dynamic range. This is achieved in the TZA3023 by implementing an Automatic Gain Control (AGC) loop.

The AGC loop consists of a peak detector, a hold capacitor and a gain control circuit. The peak amplitude of the signal is detected by the peak detector and it is stored on the hold capacitor. The voltage over the hold capacitor is compared to a threshold level. The threshold level is set to 10 μA (p-p) input current. AGC becomes active only for input signals larger than the threshold level.

It is disabled for smaller signals. The transimpedance is then at its maximum value (21 k Ω differential).

When the AGC is active, the feedback resistor of the transimpedance amplifier is reduced to keep the output voltage constant. The transimpedance is regulated from 21 k Ω at low currents ($I < 10 \mu\text{A}$) to 800 Ω at high currents ($I < 500 \mu\text{A}$). Above 500 μA the transimpedance is at its minimum and can not be reduced further but the front-end remains linear until input currents of 1.5 mA.

The upper part of Fig.7 shows the output voltages of the TZA3023 (OUT and OUTQ) as a function of the DC input current. In the lower part, the difference of both voltages is shown. It can be seen from the figure that the output changes linearly up to 10 μA input current where AGC becomes active. From this point on, AGC tries to keep the differential output voltage constant around 200 mV for medium range input currents (input currents $< 200 \mu\text{A}$). The AGC can not regulate any more above 600 μA input current, and the output voltage rises again with the input current.

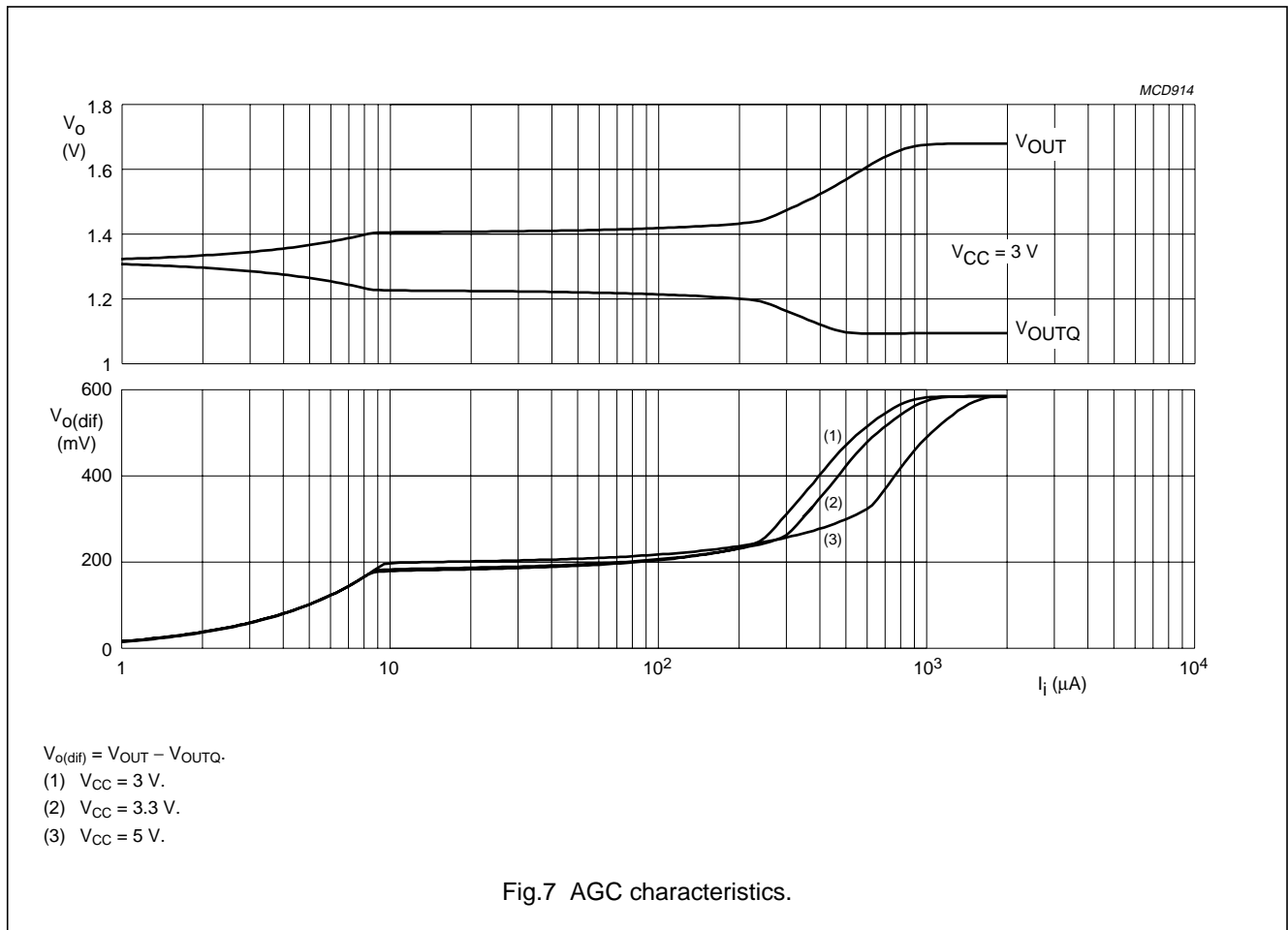

SDH/SONET STM4/OC12 transimpedance amplifier

TZA3023

LIMITING VALUES

In accordance with the Absolute Maximum Rating System (IEC 60134).

SYMBOL	PARAMETER	MIN.	MAX.	UNIT
V_{CC}	supply voltage	-0.5	+6	V
V_n	DC voltage			
	pin 3/pad 4: IPhoto	-0.5	+1	V
	pins 6 and 7/pads 9 and 10: OUT and OUTQ	-0.5	$V_{CC} + 0.5$	V
	pad 13: AGC (TZA3023U only)	-0.5	$V_{CC} + 0.5$	V
	pin 1/pad 1: DREF	-0.5	$V_{CC} + 0.5$	V
I_n	DC current			
	pin 3/pad 4: IPhoto	-1	+2.5	mA
	pins 6 and 7/pads 9 and 10: OUT and OUTQ	-15	+15	mA
	pad 13: AGC (TZA3023U only)	-0.2	+0.2	mA
	pin 1/pad 1: DREF	-2.5	+2.5	mA
P_{tot}	total power dissipation	-	300	mW
T_{stg}	storage temperature	-65	+150	°C
T_j	junction temperature	-	125	°C
T_{amb}	ambient temperature	-40	+85	°C

HANDLING

Precautions should be taken to avoid damage through electrostatic discharge. This is particularly important during assembly and handling of the bare die. Additional safety can be obtained by bonding the V_{CC} and GND pads first, the remaining pads may then be bonded to their external connections in any order.

THERMAL CHARACTERISTICS

SYMBOL	PARAMETER	VALUE	UNIT
$R_{th(j-a)}$	thermal resistance from junction to ambient	160	K/W

SDH/SONET STM4/OC12 transimpedance amplifier

TZA3023

CHARACTERISTICS

Typical values at $T_{amb} = 25\text{ °C}$ and $V_{CC} = 5\text{ V}$; minimum and maximum values are valid over the entire ambient temperature range and supply range; all voltages are measured with respect to ground; unless otherwise specified.

SYMBOL	PARAMETER	CONDITIONS	MIN.	TYP.	MAX.	UNIT
V_{CC}	supply voltage		3	5	5.5	V
I_{CC}	supply current	$V_{CC} = 5\text{ V}$; AC coupled; $R_L = 50\ \Omega$	23	28	45	mA
		$V_{CC} = 3.3\text{ V}$; AC coupled; $R_L = 50\ \Omega$	20	28	42	mA
P_{tot}	total power dissipation	$V_{CC} = 5\text{ V}$	–	140	248	mW
		$V_{CC} = 3.3\text{ V}$	–	95	152	mW
T_j	junction temperature		–40	–	+125	°C
T_{amb}	ambient temperature		–40	+25	+85	°C
R_{tr}	differential small-signal transresistance of the receiver	$V_{CC} = 5\text{ V}$; AC coupled; $R_L = 50\ \Omega$	17.5	21	25	k Ω
		$V_{CC} = 3.3\text{ V}$; AC coupled; $R_L = 50\ \Omega$	16	19.5	25	k Ω
$f_{-3dB(h)}$	high frequency –3 dB point	$V_{CC} = 5\text{ V}$; $C_i = 0.7\text{ pF}$	450	580	750	MHz
		$V_{CC} = 3.3\text{ V}$; $C_i = 0.7\text{ pF}$	440	520	600	MHz
PSRR	power supply rejection ratio	measured differentially; note 1				
		$f = 100\text{ kHz to }10\text{ MHz}$	–	1	2	$\mu\text{A/V}$
		$f = 10\text{ to }100\text{ MHz}$	–	2	5	$\mu\text{A/V}$
		$f = 100\text{ MHz to }1\text{ GHz}$	–	5	100	$\mu\text{A/V}$
Bias voltage: pin DREF						
R_{DREF}	resistance between pins DREF and V_{CC}	DC tested	1680	2000	2320	Ω
Input: pin IPhoto						
$V_{bias(IPhoto)}$	input bias voltage on pin IPhoto		720	800	970	mV
$I_{i(IPhoto)(p-p)}$	input current on pin IPhoto (peak-to-peak value)	$V_{CC} = 5\text{ V}$; note 2	–1500	+4	+1500	μA
		$V_{CC} = 3.3\text{ V}$; note 2	–1000	+4	+1000	μA
R_i	small-signal input resistance	$f_i = 1\text{ MHz}$; input current <2 μA (p-p)	–	95	–	Ω
$I_{n(tot)}$	total integrated RMS noise current over bandwidth (referenced to input)	note 3				
		$\Delta f = 311\text{ MHz}$	–	55	–	nA
		$\Delta f = 450\text{ MHz}$	–	80	–	nA
		$\Delta f = 622\text{ MHz}$	–	120	–	nA

SDH/SONET STM4/OC12 transimpedance amplifier

TZA3023

SYMBOL	PARAMETER	CONDITIONS	MIN.	TYP.	MAX.	UNIT
Data outputs: pins OUT and OUTQ						
$V_{o(cm)}$	common mode output voltage	AC coupled; $R_L = 50 \Omega$	$V_{CC} - 2$	$V_{CC} - 1.7$	$V_{CC} - 1.4$	V
$V_{o(se)(p-p)}$	single-ended output voltage (peak-to-peak value)	AC coupled; $R_L = 50 \Omega$; input current $100 \mu A$ (p-p)	75	200	330	mV
V_{OO}	differential output offset voltage		-100	0	+100	mV
$R_{o(se)}$	single-ended output resistance	DC tested	40	50	62	Ω
t_r, t_f	rise time, fall time	$V_{CC} = 5 V$; 20% to 80%; input current $<10 \mu A$ (p-p)	400	510	700	ps
		$V_{CC} = 3.3 V$; 20% to 80%; input current $<10 \mu A$ (p-p)	450	550	700	ps
Automatic gain control loop: pad AGC						
$I_{th(AGC)}$	AGC threshold current	referred to the peak input current; tested at 10 MHz	-	10	-	μA
$t_{att(AGC)}$	AGC attack time		-	5	-	μs
$t_{decay(AGC)}$	AGC decay time		-	10	-	ms

Notes

- PSRR is defined as the ratio of the equivalent current change at the input (ΔI_{Photo}) to a change in supply voltage:

$$PSRR = \frac{\Delta I_{Photo}}{\Delta V_{CC}}$$

For example, a +4 mV disturbance on V_{CC} at 10 MHz will typically add an extra 8 nA to the photodiode current. The external capacitor between pins DREF and GND has a large impact on the PSRR. The specification is valid with an external capacitor of 1 nF. The PSRR is guaranteed by design.

- The Pulse Width Distortion (PWD) is <5% over the whole input current range. The PWD is defined as:

$$PWD = \left(\frac{\text{pulse width}}{T} - 1 \right) \times 100\% \text{ where } T \text{ is the clock period. The PWD is measured differentially with}$$

PRBS pattern of 10^{-23} .

- All $I_{n(tot)}$ measurements were made with an input capacitance of $C_i = 1.2$ pF. This was comprised of 0.7 pF for the photodiode itself, with 0.3 pF allowed for the printed-circuit board layout and 0.2 pF intrinsic to the package. Noise performance is measured differentially.

SDH/SONET STM4/OC12
transimpedance amplifier

TZA3023

TYPICAL PERFORMANCE CHARACTERISTICS

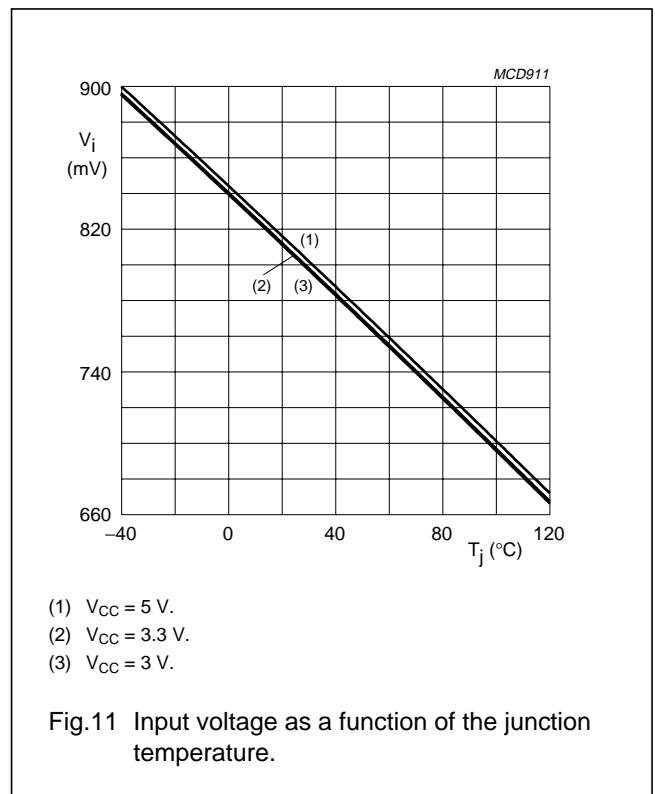
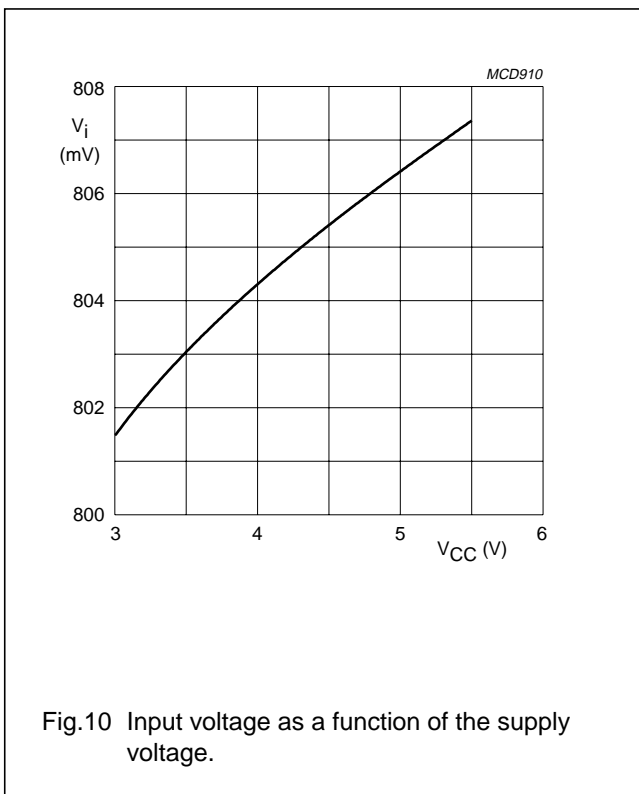
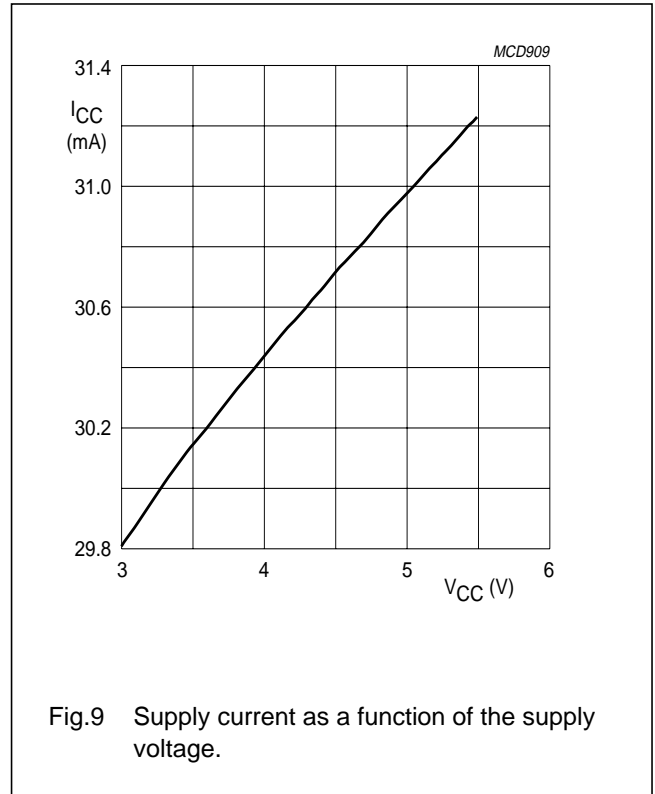
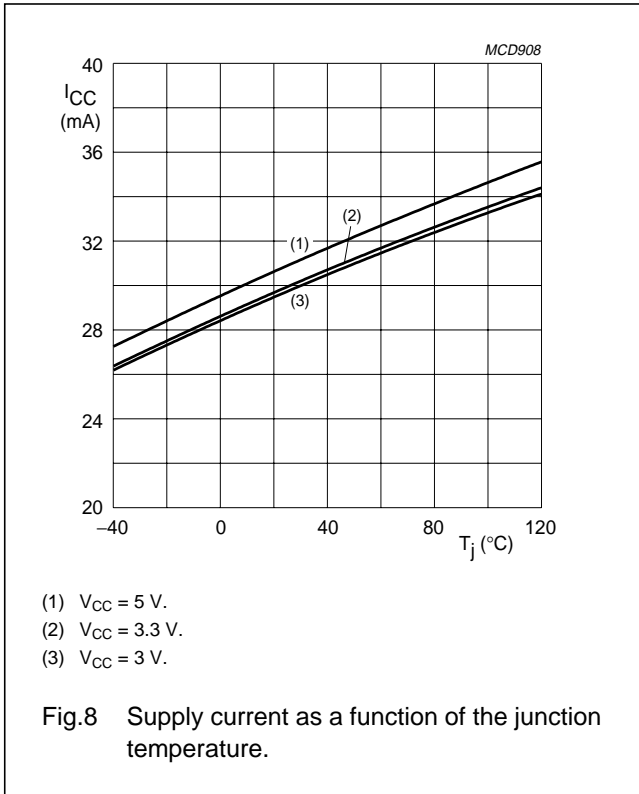

SDH/SONET STM4/OC12
transimpedance amplifier

TZA3023

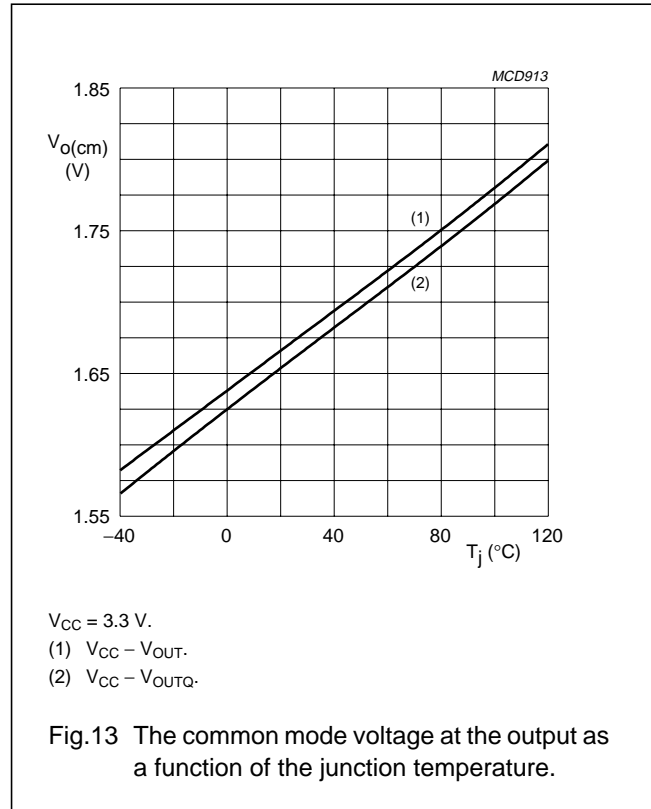
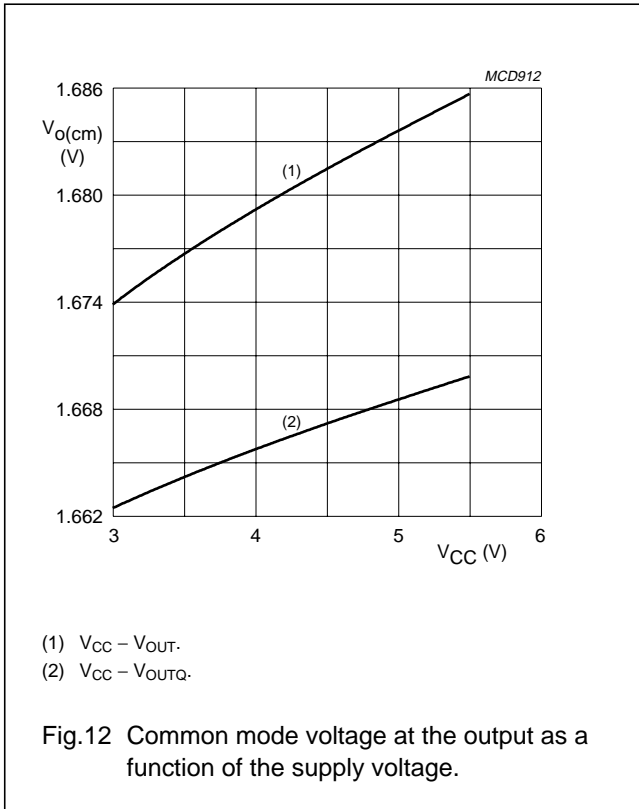

SDH/SONET STM4/OC12 transimpedance amplifier

TZA3023

APPLICATION AND TEST INFORMATION

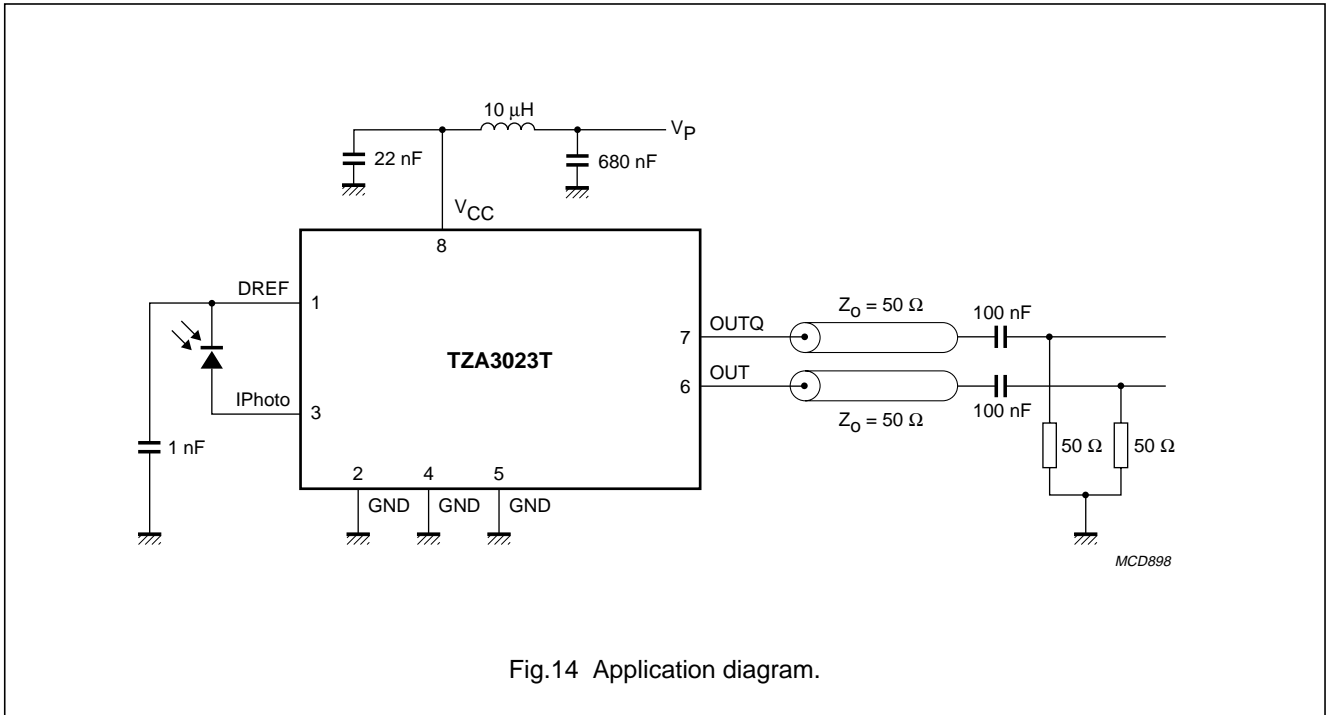

SDH/SONET STM4/OC12
transimpedance amplifier

TZA3023

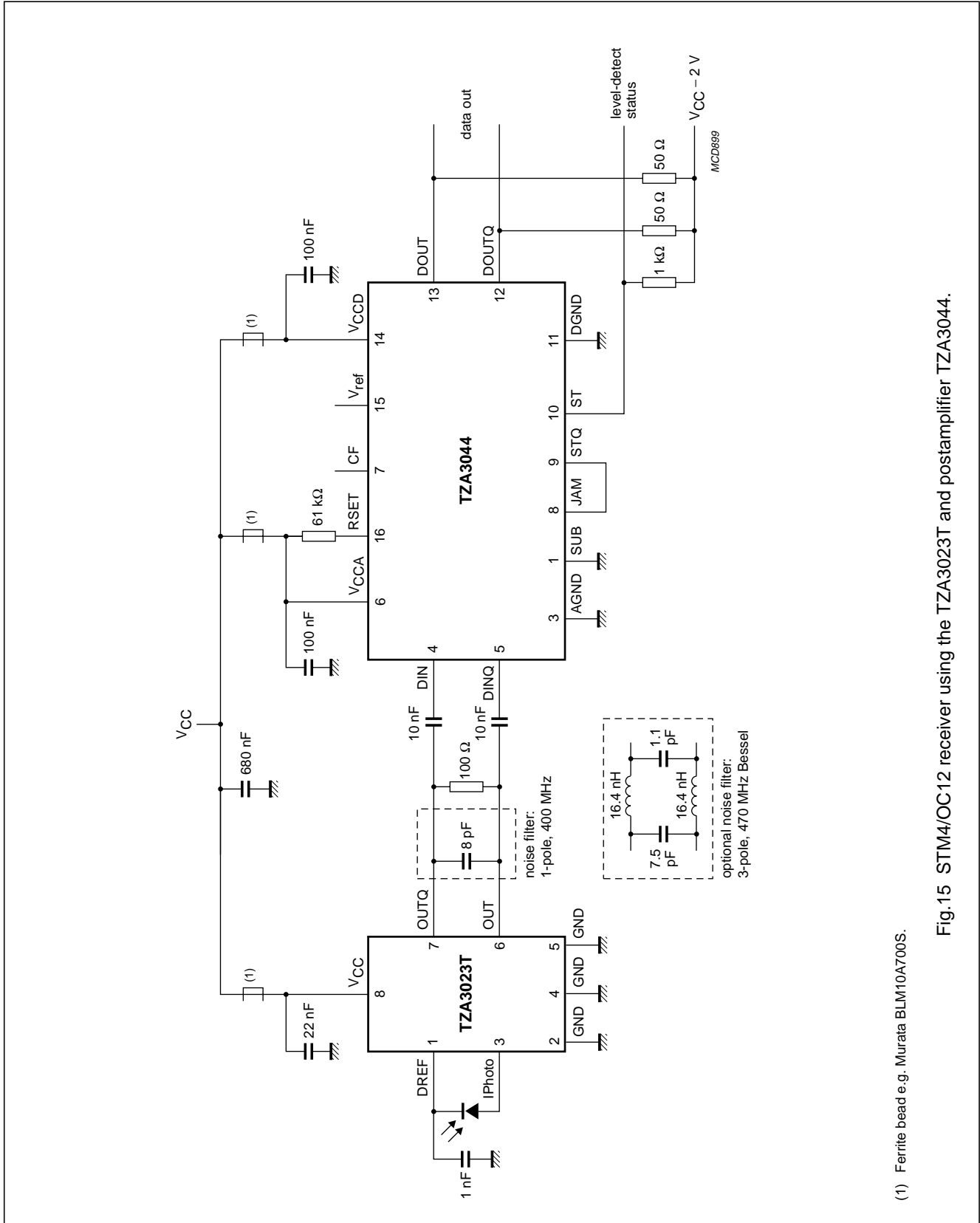

(1) Ferrite bead e.g. Murata BLM10A700S.

Fig.15 STM4/OC12 receiver using the TZA3023T and postamplifier TZA3044.

SDH/SONET STM4/OC12
transimpedance amplifier

TZA3023

Test circuits

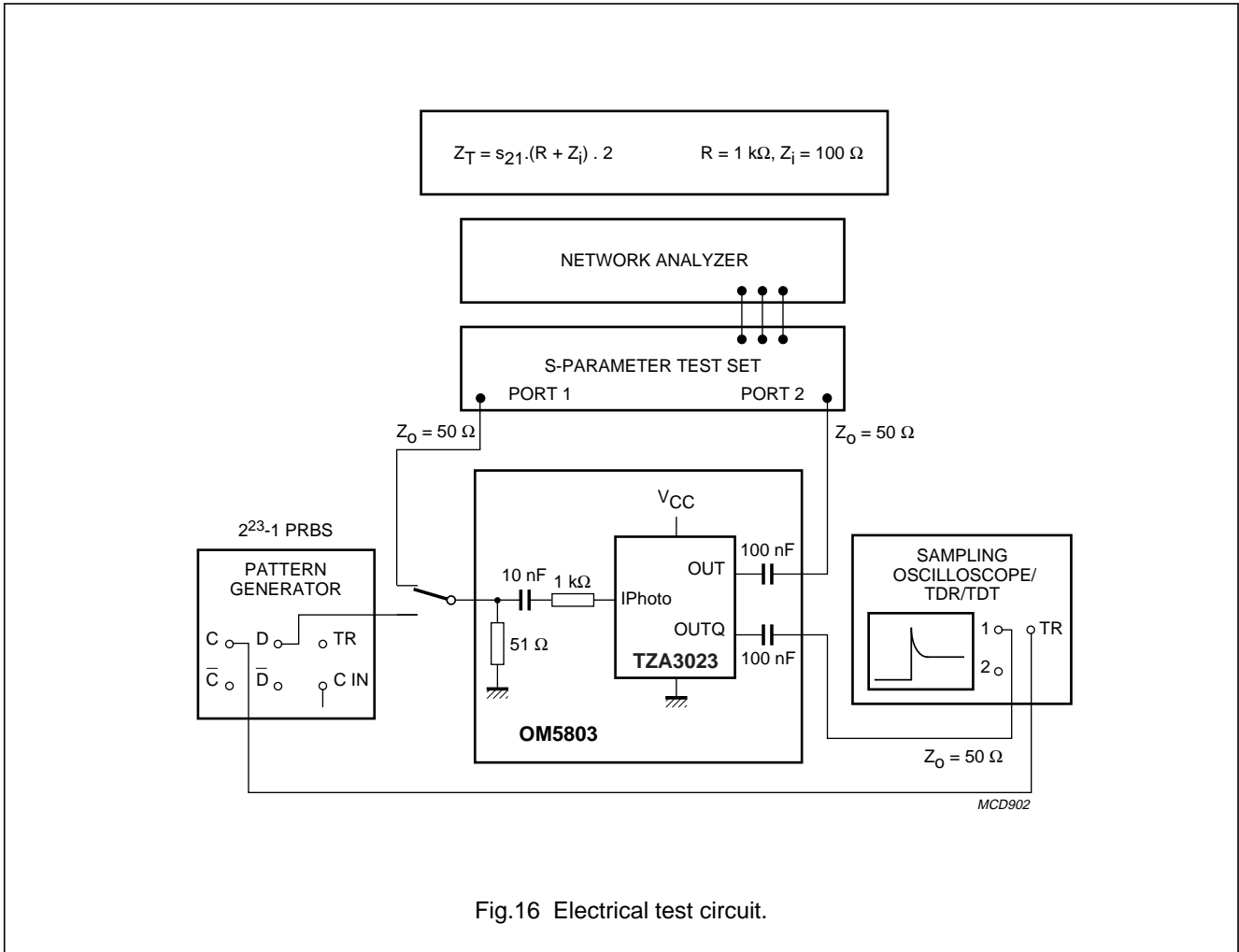

SDH/SONET STM4/OC12
transimpedance amplifier

TZA3023

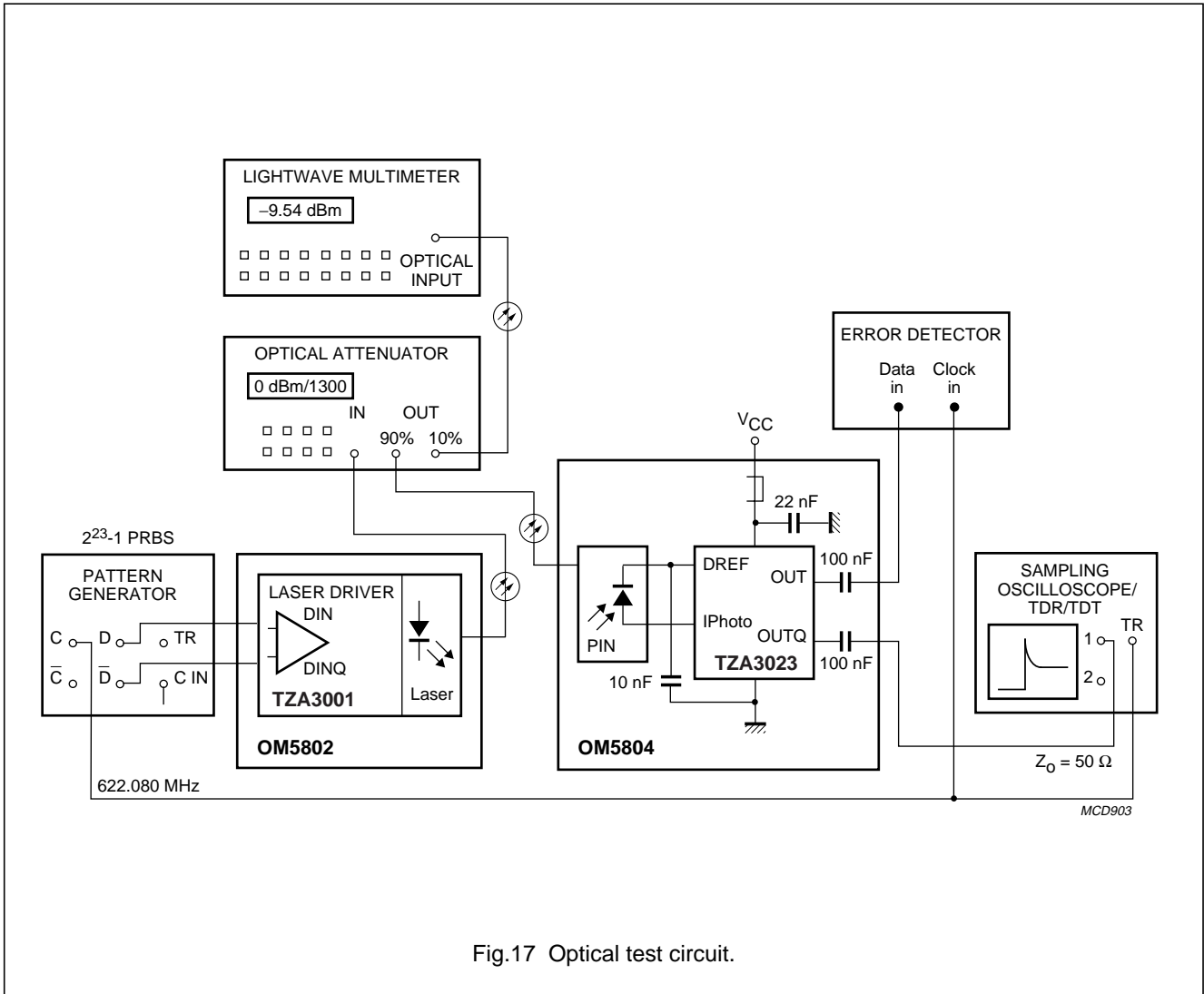

SDH/SONET STM4/OC12
transimpedance amplifier

TZA3023

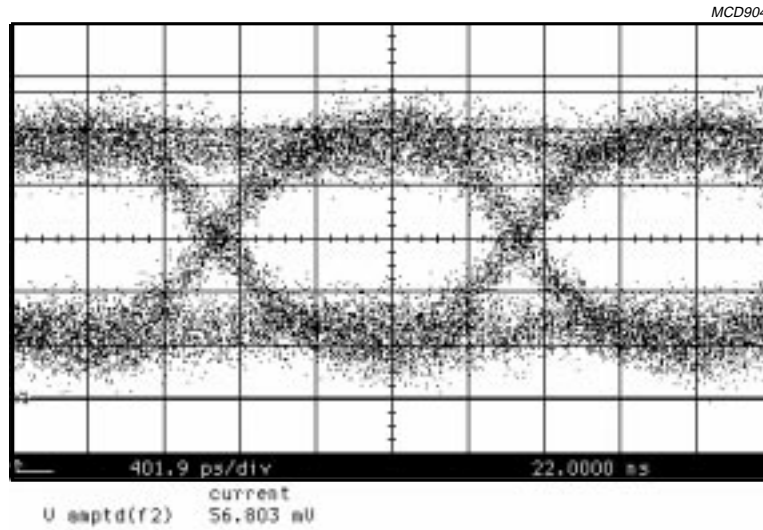

Fig.18 Differential output with -30 dBm optical input power [input current of $1.63 \mu\text{A}$ (p-p)].

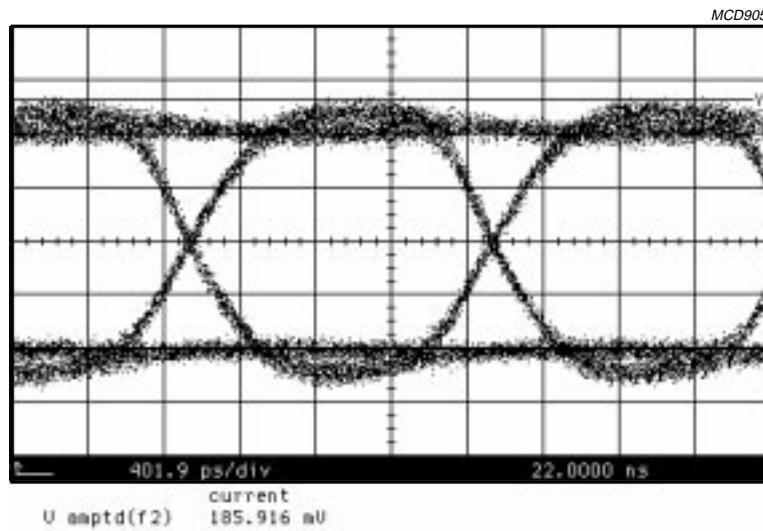

Fig.19 Differential output with -20 dBm optical input power [input current of $16.3 \mu\text{A}$ (p-p)].

SDH/SONET STM4/OC12
transimpedance amplifier

TZA3023

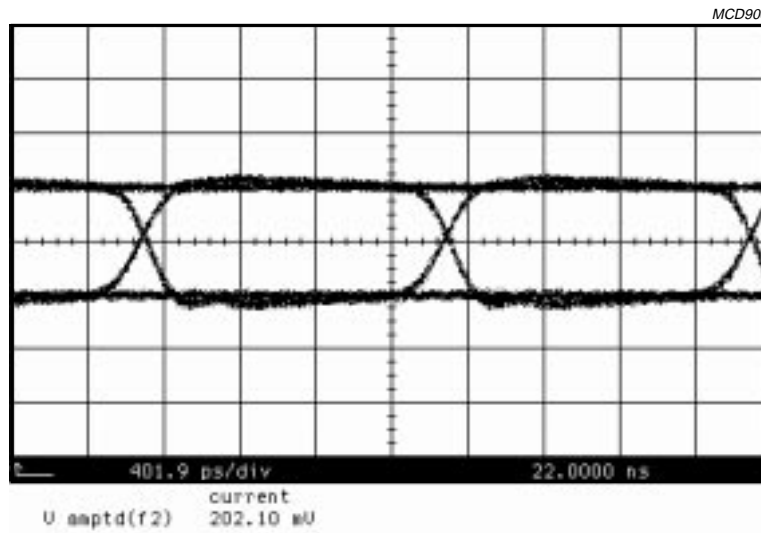

Fig.20 Differential output with -10 dBm optical input power [input current of $163 \mu\text{A}$ (p-p)].

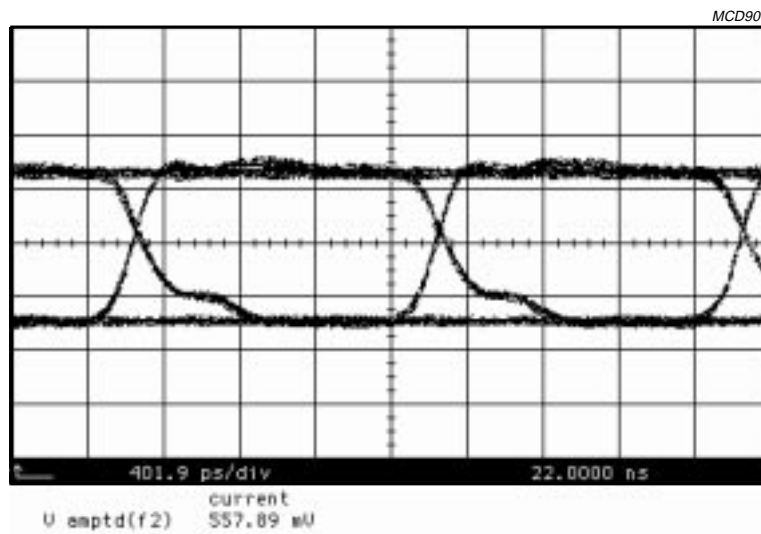

Fig.21 Differential output with -2 dBm optical input power [input current of $1030 \mu\text{A}$ (p-p)].

SDH/SONET STM4/OC12
transimpedance amplifier

TZA3023

BONDING PAD LOCATIONS

SYMBOL	PAD	COORDINATES ⁽¹⁾	
		x	y
DREF	1	95	881
GND	2	95	618
GND	3	95	473
IPhoto	4	95	285
GND	5	215	95
GND	6	360	95
GND	7	549	95
GND	8	691	95
OUT	9	785	501
OUTQ	10	785	641
V _{CC}	11	567	1055
V _{CC}	12	424	1055
AGC	13	259	1055

Note

1. All coordinates are referenced, in μm , to the bottom left-hand corner of the die.

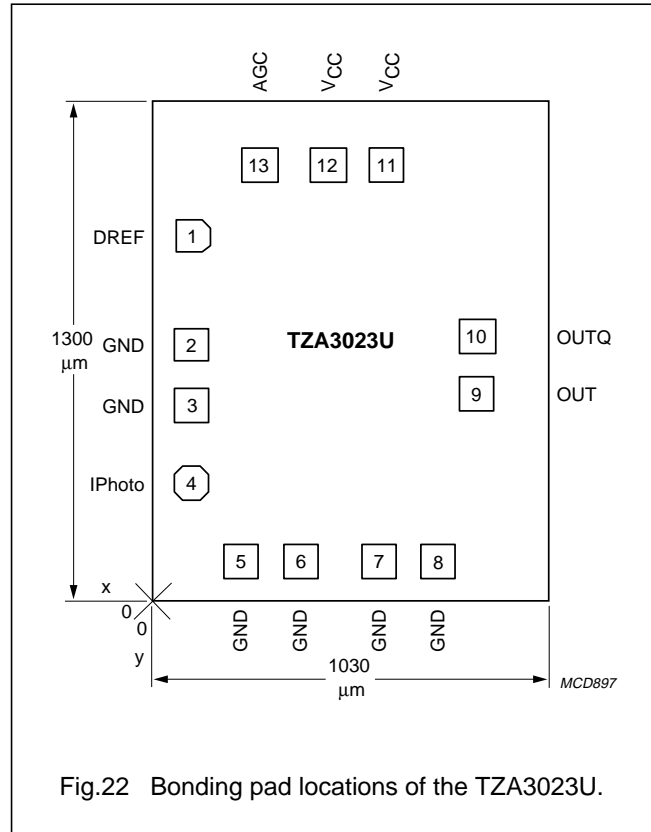

Fig.22 Bonding pad locations of the TZA3023U.

Physical characteristics of the bare die

PARAMETER	VALUE
Glass passivation	2.1 μm PSG (PhosphoSilicate Glass) on top of 0.65 μm oxynitride
Bonding pad dimension	minimum dimension of exposed metallization is $90 \times 90 \mu\text{m}$ (pad size = $100 \times 100 \mu\text{m}$)
Metallization	1.22 μm W/AICu/TiW
Thickness	380 μm nominal
Size	$1.03 \times 1.30 \text{ mm}$ (1.34 mm^2)
Backing	silicon; electrically connected to GND potential through substrate contacts
Attach temperature	<440 °C; recommended die attach is glue
Attach time	<15 s

SDH/SONET STM4/OC12
transimpedance amplifier

TZA3023

PACKAGE OUTLINE

SO8: plastic small outline package; 8 leads; body width 3.9 mm

SOT96-1

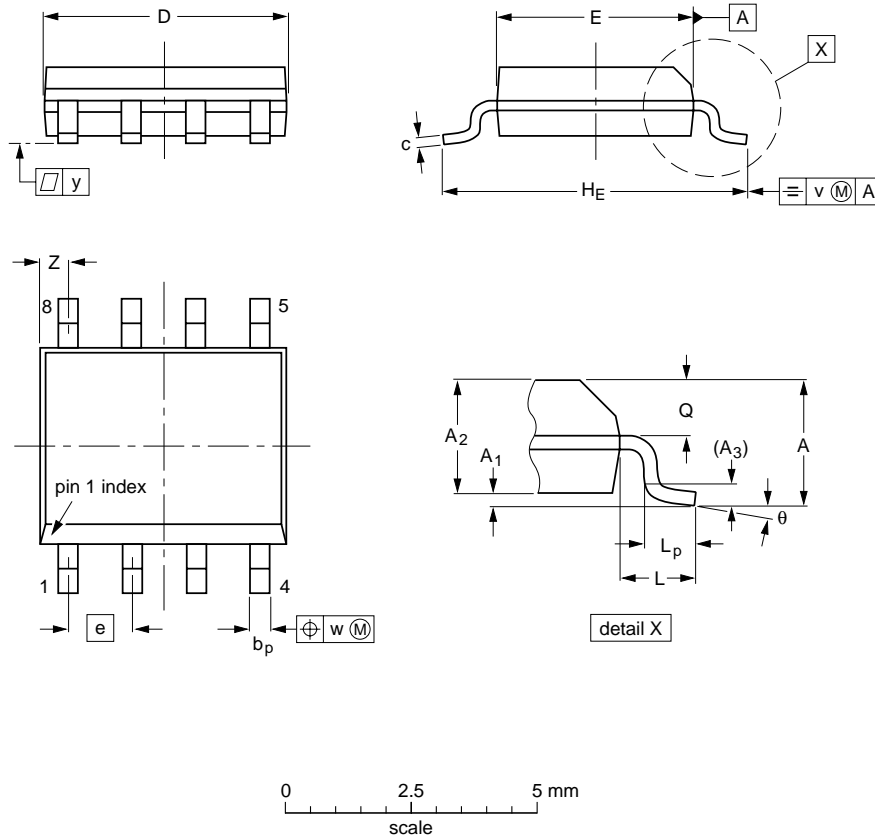

DIMENSIONS (inch dimensions are derived from the original mm dimensions)

UNIT	A max.	A ₁	A ₂	A ₃	b _p	c	D ⁽¹⁾	E ⁽²⁾	e	H _E	L	L _p	Q	v	w	y	Z ⁽¹⁾	θ
mm	1.75	0.25 0.10	1.45 1.25	0.25	0.49 0.36	0.25 0.19	5.0 4.8	4.0 3.8	1.27	6.2 5.8	1.05	1.0 0.4	0.7 0.6	0.25	0.25	0.1	0.7 0.3	8° 0°
inches	0.069	0.010 0.004	0.057 0.049	0.01	0.019 0.014	0.0100 0.0075	0.20 0.19	0.16 0.15	0.050	0.244 0.228	0.041	0.039 0.016	0.028 0.024	0.01	0.01	0.004	0.028 0.012	

Notes

1. Plastic or metal protrusions of 0.15 mm maximum per side are not included.
2. Plastic or metal protrusions of 0.25 mm maximum per side are not included.

OUTLINE VERSION	REFERENCES			EUROPEAN PROJECTION	ISSUE DATE
	IEC	JEDEC	EIAJ		
SOT96-1	076E03	MS-012			97-05-22 99-12-27

SDH/SONET STM4/OC12 transimpedance amplifier

TZA3023

SOLDERING

Introduction to soldering surface mount packages

This text gives a very brief insight to a complex technology. A more in-depth account of soldering ICs can be found in our "Data Handbook IC26; Integrated Circuit Packages" (document order number 9398 652 90011).

There is no soldering method that is ideal for all surface mount IC packages. Wave soldering is not always suitable for surface mount ICs, or for printed-circuit boards with high population densities. In these situations reflow soldering is often used.

Reflow soldering

Reflow soldering requires solder paste (a suspension of fine solder particles, flux and binding agent) to be applied to the printed-circuit board by screen printing, stencilling or pressure-syringe dispensing before package placement.

Several methods exist for reflowing; for example, infrared/convection heating in a conveyor type oven. Throughput times (preheating, soldering and cooling) vary between 100 and 200 seconds depending on heating method.

Typical reflow peak temperatures range from 215 to 250 °C. The top-surface temperature of the packages should preferably be kept below 230 °C.

Wave soldering

Conventional single wave soldering is not recommended for surface mount devices (SMDs) or printed-circuit boards with a high component density, as solder bridging and non-wetting can present major problems.

To overcome these problems the double-wave soldering method was specifically developed.

If wave soldering is used the following conditions must be observed for optimal results:

- Use a double-wave soldering method comprising a turbulent wave with high upward pressure followed by a smooth laminar wave.
- For packages with leads on two sides and a pitch (e):
 - larger than or equal to 1.27 mm, the footprint longitudinal axis is **preferred** to be parallel to the transport direction of the printed-circuit board;
 - smaller than 1.27 mm, the footprint longitudinal axis **must** be parallel to the transport direction of the printed-circuit board.

The footprint must incorporate solder thieves at the downstream end.

- For packages with leads on four sides, the footprint must be placed at a 45° angle to the transport direction of the printed-circuit board. The footprint must incorporate solder thieves downstream and at the side corners.

During placement and before soldering, the package must be fixed with a droplet of adhesive. The adhesive can be applied by screen printing, pin transfer or syringe dispensing. The package can be soldered after the adhesive is cured.

Typical dwell time is 4 seconds at 250 °C.

A mildly-activated flux will eliminate the need for removal of corrosive residues in most applications.

Manual soldering

Fix the component by first soldering two diagonally-opposite end leads. Use a low voltage (24 V or less) soldering iron applied to the flat part of the lead. Contact time must be limited to 10 seconds at up to 300 °C.

When using a dedicated tool, all other leads can be soldered in one operation within 2 to 5 seconds between 270 and 320 °C.

SDH/SONET STM4/OC12 transimpedance amplifier

TZA3023

Suitability of surface mount IC packages for wave and reflow soldering methods

PACKAGE	SOLDERING METHOD	
	WAVE	REFLOW ⁽¹⁾
BGA, LFBGA, SQFP, TFBGA	not suitable	suitable
HBCC, HLQFP, HSQFP, HSOP, HTQFP, HTSSOP, SMS	not suitable ⁽²⁾	suitable
PLCC ⁽³⁾ , SO, SOJ	suitable	suitable
LQFP, QFP, TQFP	not recommended ⁽³⁾⁽⁴⁾	suitable
SSOP, TSSOP, VSO	not recommended ⁽⁵⁾	suitable

Notes

- All surface mount (SMD) packages are moisture sensitive. Depending upon the moisture content, the maximum temperature (with respect to time) and body size of the package, there is a risk that internal or external package cracks may occur due to vaporization of the moisture in them (the so called popcorn effect). For details, refer to the Drypack information in the *"Data Handbook IC26; Integrated Circuit Packages; Section: Packing Methods"*.
- These packages are not suitable for wave soldering as a solder joint between the printed-circuit board and heatsink (at bottom version) can not be achieved, and as solder may stick to the heatsink (on top version).
- If wave soldering is considered, then the package must be placed at a 45° angle to the solder wave direction. The package footprint must incorporate solder thieves downstream and at the side corners.
- Wave soldering is only suitable for LQFP, TQFP and QFP packages with a pitch (e) equal to or larger than 0.8 mm; it is definitely not suitable for packages with a pitch (e) equal to or smaller than 0.65 mm.
- Wave soldering is only suitable for SSOP and TSSOP packages with a pitch (e) equal to or larger than 0.65 mm; it is definitely not suitable for packages with a pitch (e) equal to or smaller than 0.5 mm.

SDH/SONET STM4/OC12 transimpedance amplifier

TZA3023

DATA SHEET STATUS

DATA SHEET STATUS	PRODUCT STATUS	DEFINITIONS ⁽¹⁾
Objective specification	Development	This data sheet contains the design target or goal specifications for product development. Specification may change in any manner without notice.
Preliminary specification	Qualification	This data sheet contains preliminary data, and supplementary data will be published at a later date. Philips Semiconductors reserves the right to make changes at any time without notice in order to improve design and supply the best possible product.
Product specification	Production	This data sheet contains final specifications. Philips Semiconductors reserves the right to make changes at any time without notice in order to improve design and supply the best possible product.

Note

1. Please consult the most recently issued data sheet before initiating or completing a design.

DEFINITIONS

Short-form specification — The data in a short-form specification is extracted from a full data sheet with the same type number and title. For detailed information see the relevant data sheet or data handbook.

Limiting values definition — Limiting values given are in accordance with the Absolute Maximum Rating System (IEC 60134). Stress above one or more of the limiting values may cause permanent damage to the device. These are stress ratings only and operation of the device at these or at any other conditions above those given in the Characteristics sections of the specification is not implied. Exposure to limiting values for extended periods may affect device reliability.

Application information — Applications that are described herein for any of these products are for illustrative purposes only. Philips Semiconductors make no representation or warranty that such applications will be suitable for the specified use without further testing or modification.

DISCLAIMERS

Life support applications — These products are not designed for use in life support appliances, devices, or systems where malfunction of these products can reasonably be expected to result in personal injury. Philips Semiconductors customers using or selling these products for use in such applications do so at their own risk and agree to fully indemnify Philips Semiconductors for any damages resulting from such application.

Right to make changes — Philips Semiconductors reserves the right to make changes, without notice, in the products, including circuits, standard cells, and/or software, described or contained herein in order to improve design and/or performance. Philips Semiconductors assumes no responsibility or liability for the use of any of these products, conveys no licence or title under any patent, copyright, or mask work right to these products, and makes no representations or warranties that these products are free from patent, copyright, or mask work right infringement, unless otherwise specified.

BARE DIE DISCLAIMER

All die are tested and are guaranteed to comply with all data sheet limits up to the point of wafer sawing for a period of ninety (90) days from the date of Philips' delivery. If there are data sheet limits not guaranteed, these will be separately indicated in the data sheet. There are no post packing tests performed on individual die or wafer. Philips Semiconductors has no control of third party procedures in the sawing, handling, packing or assembly of the die. Accordingly, Philips Semiconductors assumes no liability for device functionality or performance of the die or systems after third party sawing, handling, packing or assembly of the die. It is the responsibility of the customer to test and qualify their application in which the die is used.

SDH/SONET STM4/OC12
transimpedance amplifier

TZA3023

NOTES

Philips Semiconductors – a worldwide company

Argentina: see South America

Australia: 3 Figtree Drive, HOMEBUSH, NSW 2140,
Tel. +61 2 9704 8141, Fax. +61 2 9704 8139

Austria: Computerstr. 6, A-1101 WIEN, P.O. Box 213,
Tel. +43 1 60 101 1248, Fax. +43 1 60 101 1210

Belarus: Hotel Minsk Business Center, Bld. 3, r. 1211, Volodarski Str. 6,
220050 MINSK, Tel. +375 172 20 0733, Fax. +375 172 20 0773

Belgium: see The Netherlands

Brazil: see South America

Bulgaria: Philips Bulgaria Ltd., Energoproject, 15th floor,
51 James Bourchier Blvd., 1407 SOFIA,
Tel. +359 2 68 9211, Fax. +359 2 68 9102

Canada: PHILIPS SEMICONDUCTORS/COMPONENTS,
Tel. +1 800 234 7381, Fax. +1 800 943 0087

China/Hong Kong: 501 Hong Kong Industrial Technology Centre,
72 Tat Chee Avenue, Kowloon Tong, HONG KONG,
Tel. +852 2319 7888, Fax. +852 2319 7700

Colombia: see South America

Czech Republic: see Austria

Denmark: Sydhavnsgade 23, 1780 COPENHAGEN V,
Tel. +45 33 29 3333, Fax. +45 33 29 3905

Finland: Sinikalliontie 3, FIN-02630 ESPOO,
Tel. +358 9 615 800, Fax. +358 9 6158 0920

France: 51 Rue Carnot, BP317, 92156 SURESNES Cedex,
Tel. +33 1 4099 6161, Fax. +33 1 4099 6427

Germany: Hammerbrookstraße 69, D-20097 HAMBURG,
Tel. +49 40 2353 60, Fax. +49 40 2353 6300

Hungary: see Austria

India: Philips INDIA Ltd, Band Box Building, 2nd floor,
254-D, Dr. Annie Besant Road, Worli, MUMBAI 400 025,
Tel. +91 22 493 8541, Fax. +91 22 493 0966

Indonesia: PT Philips Development Corporation, Semiconductors Division,
Gedung Philips, Jl. Buncit Raya Kav.99-100, JAKARTA 12510,
Tel. +62 21 794 0040 ext. 2501, Fax. +62 21 794 0080

Ireland: Newstead, Clonskeagh, DUBLIN 14,
Tel. +353 1 7640 000, Fax. +353 1 7640 200

Israel: RAPAC Electronics, 7 Kehilat Saloniki St, PO Box 18053,
TEL AVIV 61180, Tel. +972 3 645 0444, Fax. +972 3 649 1007

Italy: PHILIPS SEMICONDUCTORS, Via Casati, 23 - 20052 MONZA (MI),
Tel. +39 039 203 6838, Fax +39 039 203 6800

Japan: Philips Bldg 13-37, Kohnan 2-chome, Minato-ku,
TOKYO 108-8507, Tel. +81 3 3740 5130, Fax. +81 3 3740 5057

Korea: Philips House, 260-199 Itaewon-dong, Yongsan-ku, SEOUL,
Tel. +82 2 709 1412, Fax. +82 2 709 1415

Malaysia: No. 76 Jalan Universiti, 46200 PETALING JAYA, SELANGOR,
Tel. +60 3 750 5214, Fax. +60 3 757 4880

Mexico: 5900 Gateway East, Suite 200, EL PASO, TEXAS 79905,
Tel. +9-5 800 234 7381, Fax +9-5 800 943 0087

Middle East: see Italy

Netherlands: Postbus 90050, 5600 PB EINDHOVEN, Bldg. VB,
Tel. +31 40 27 82785, Fax. +31 40 27 88399

New Zealand: 2 Wagener Place, C.P.O. Box 1041, AUCKLAND,
Tel. +64 9 849 4160, Fax. +64 9 849 7811

Norway: Box 1, Manglerud 0612, OSLO,
Tel. +47 22 74 8000, Fax. +47 22 74 8341

Pakistan: see Singapore

Philippines: Philips Semiconductors Philippines Inc.,
106 Valero St. Salcedo Village, P.O. Box 2108 MCC, MAKATI,
Metro MANILA, Tel. +63 2 816 6380, Fax. +63 2 817 3474

Poland: Al.Jerozolimskie 195 B, 02-222 WARSAW,
Tel. +48 22 5710 000, Fax. +48 22 5710 001

Portugal: see Spain

Romania: see Italy

Russia: Philips Russia, Ul. Usatcheva 35A, 119048 MOSCOW,
Tel. +7 095 755 6918, Fax. +7 095 755 6919

Singapore: Lorong 1, Toa Payoh, SINGAPORE 319762,
Tel. +65 350 2538, Fax. +65 251 6500

Slovakia: see Austria

Slovenia: see Italy

South Africa: S.A. PHILIPS Pty Ltd., 195-215 Main Road Martindale,
2092 JOHANNESBURG, P.O. Box 58088 Newville 2114,
Tel. +27 11 471 5401, Fax. +27 11 471 5398

South America: Al. Vicente Pinzon, 173, 6th floor,
04547-130 SÃO PAULO, SP, Brazil,
Tel. +55 11 821 2333, Fax. +55 11 821 2382

Spain: Balmes 22, 08007 BARCELONA,
Tel. +34 93 301 6312, Fax. +34 93 301 4107

Sweden: Kottbygatan 7, Akalla, S-16485 STOCKHOLM,
Tel. +46 8 5985 2000, Fax. +46 8 5985 2745

Switzerland: Allmendstrasse 140, CH-8027 ZÜRICH,
Tel. +41 1 488 2741 Fax. +41 1 488 3263

Taiwan: Philips Semiconductors, 6F, No. 96, Chien Kuo N. Rd., Sec. 1,
TAIPEI, Taiwan Tel. +886 2 2134 2886, Fax. +886 2 2134 2874

Thailand: PHILIPS ELECTRONICS (THAILAND) Ltd.,
209/2 Sanpavuth-Bangna Road Prakanong, BANGKOK 10260,
Tel. +66 2 745 4090, Fax. +66 2 398 0793

Turkey: Yukari Dudullu, Org. San. Blg., 2.Cad. Nr. 28 81260 Umraniye,
ISTANBUL, Tel. +90 216 522 1500, Fax. +90 216 522 1813

Ukraine: PHILIPS UKRAINE, 4 Patrice Lumumba str., Building B, Floor 7,
252042 KIEV, Tel. +380 44 264 2776, Fax. +380 44 268 0461

United Kingdom: Philips Semiconductors Ltd., 276 Bath Road, Hayes,
MIDDLESEX UB3 5BX, Tel. +44 208 730 5000, Fax. +44 208 754 8421

United States: 811 East Arques Avenue, SUNNYVALE, CA 94088-3409,
Tel. +1 800 234 7381, Fax. +1 800 943 0087

Uruguay: see South America

Vietnam: see Singapore

Yugoslavia: PHILIPS, Trg N. Pasica 5/v, 11000 BEOGRAD,
Tel. +381 11 3341 299, Fax.+381 11 3342 553

For all other countries apply to: Philips Semiconductors,
International Marketing & Sales Communications, Building BE-p, P.O. Box 218,
5600 MD EINDHOVEN, The Netherlands, Fax. +31 40 27 24825

Internet: <http://www.semiconductors.philips.com>

© Philips Electronics N.V. 2000

SCA 69

All rights are reserved. Reproduction in whole or in part is prohibited without the prior written consent of the copyright owner.

The information presented in this document does not form part of any quotation or contract, is believed to be accurate and reliable and may be changed without notice. No liability will be accepted by the publisher for any consequence of its use. Publication thereof does not convey nor imply any license under patent- or other industrial or intellectual property rights.

Printed in The Netherlands

403510/200/02/pp24

Date of release: 2000 Mar 29

Document order number: 9397 750 06816

Let's make things better.

Philips



PHILIPS