

AM/FM Receiver for Digital Tuning with FM-Stereo Decoder

Description

The U2514B is an integrated bipolar radio suitable for digital tuning systems. It contains a FM front end with pre-amplifier and FM-stereo decoder as well as a complete AM receiver and demodulator. Stop-signal

generation is implemented for FM and AM mode. This circuit is designed for use in small radios, power packs and multimedia applications

Features

- FM wideband AGC
- LO-buffer for digital tuning
- Integrated stop signal generation with true AM/ FM discriminators
- Adjustable stop signal sensitivity
- Automatic stereo-mono-blend
- High cut
- Mute function
- Pilot canceller
- Supply voltage range 3 to 12 V
- Package: SSO28

Block Diagram

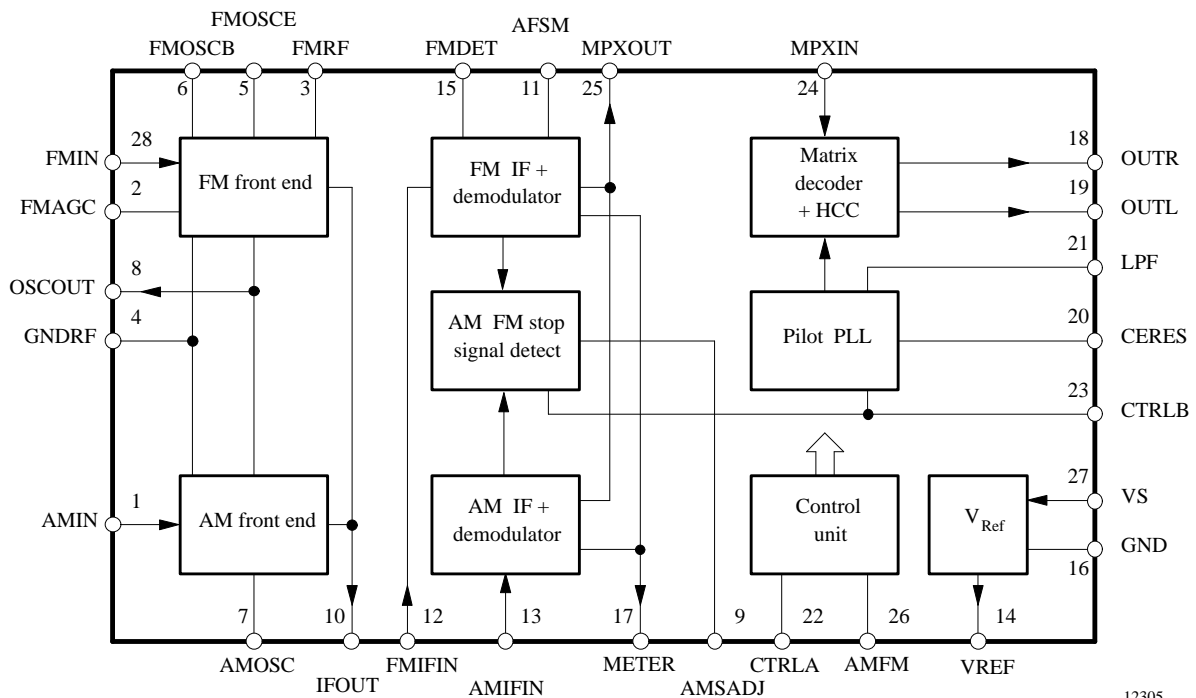

Figure 1.

Pin Description

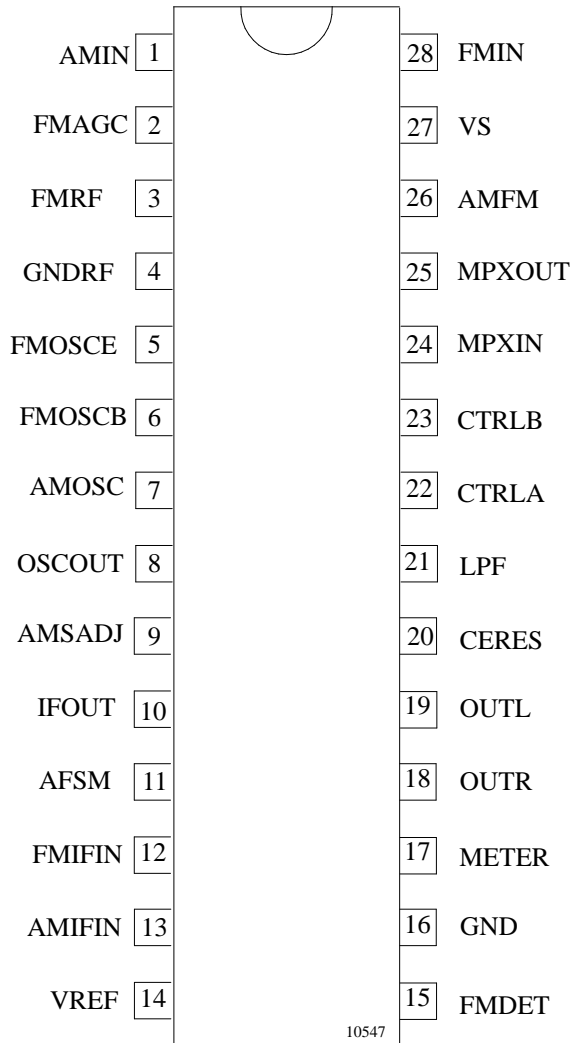

Figure 2. Pinning

Pin	Symbol	Function
1	AMIN	AM antenna input
2	FMAGC	FM-AGC time constant
3	FMRF	FM RF tank
4	GNDRF	Ground RF
5	FMOSCE	FM oscillator emitter
6	FMOSCB	FM oscillator basis
7	AMOSC	AM oscillator
8	OSCOUT	Buffered AM/FM oscillator output
9	AMSADJ	Current-input for AM stop signal adjust
10	IFOUT	AM/FM IF output
11	AFSM	AF smoothing voltage
12	FMIFIN	FM IF amplifier input
13	AMIFIN	AM IF amplifier input
14	VREF	Reference voltage
15	FMDDET	FM discriminator output
16	GND	Ground
17	METER	Fieldstrength voltage output
18	OUTR	AF output right
19	OUTL	AF output left
20	CERES	Resonator 456 kHz
21	LPF	Low pass filter for Pilot-PLL
22	CTRLA	Control input for mute, search mode and search sensitivity
23	CTRLB	Control input for forced mono, control output for stop function and stereo information
24	MPXIN	Stereo decoder MPX input
25	MPXOUT	AM/FM MPX output
26	AMFM	AM/FM switch and pilot canceller time constant
27	VS	Supply voltage
28	FMIN	FM antenna input

Ordering and Package Information

Extended Type Number	Package	Remarks
U2514B-AFN	SSO28	
U2514B-AFNG3	SSO28	Taping according to ICE-286-3

Pin Description

FMIN, FMAGC, FMRF

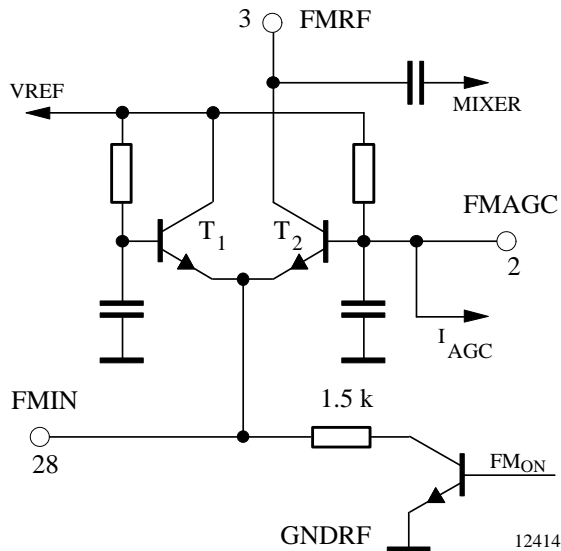

Figure 3.

The FM pre-amplifier input FMIN (Pin 28) consists of a transistor grounded base circuit (T_2) which provides excellent noise performance and large signal behavior. It is recommended to connect a source impedance of 100Ω in order to achieve optimal performance. The dc current through the amplifying transistor is reduced by the internal AGC. This means in the case of large input signals, the input ac current is bypassed via the wideband AGC transistor T_1 . A capacitor is connected between FMAGC (Pin 2) and GNDRF (Pin 4). It shortens the transistor base to GNDRF and it also serves for smoothing of the AGC voltage. A tuned RF circuit is connected between FMRF (Pin 3) and VS (Pin 27). The amplified RF signal is fed internally to the mixer input.

FMOSCE, FMOSCB

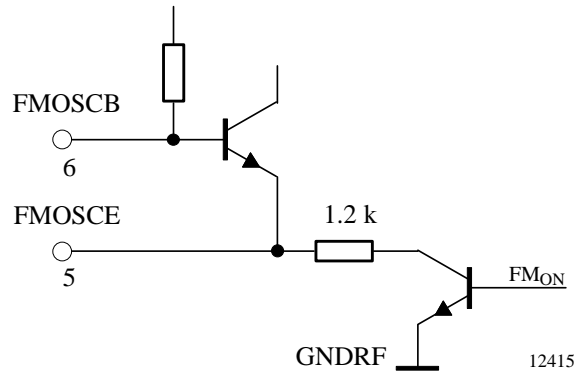

Figure 4.

The FM local oscillator consists of a transistor in grounded collector configuration. The negative resistance at the base of the transistor is generated by an external capacitor connected between emitter FMOSCE (Pin 5) and GNDRF (Pin 4). An other external capacitor is connected between base FMOSCB (Pin 6) and emitter FMOSCE (Pin 5) which increases the resistance at the emitter and leads to a higher oscillator swing. The negative resistance at FMOSCB is approximately 250Ω . Therefore, the resonant LO tank resistance of approximately $5 k\Omega$ (depends on Q-factor of the coil) is transformed to this magnitude via a capacitor.

OSCOUT

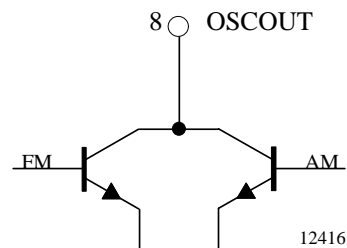

Figure 5.

A resistor is connected between OSCOUT (Pin 8) and VREF (Pin 14). It determines the amplitude of oscillator voltage which is fed to the PLL circuit. The TEMIC PLL family U428xBM is recommended because it offers high signal to noise ratio and low current consumption.

AMIN

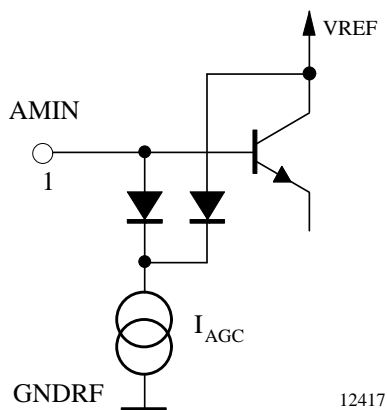

Figure 6.

The AM antenna coil is connected between AMIN (Pin 1) and VREF (Pin 14). In order to ensure that the AGC operates correctly, a coil impedance of approximately 25 kΩ is necessary.

AMOSC

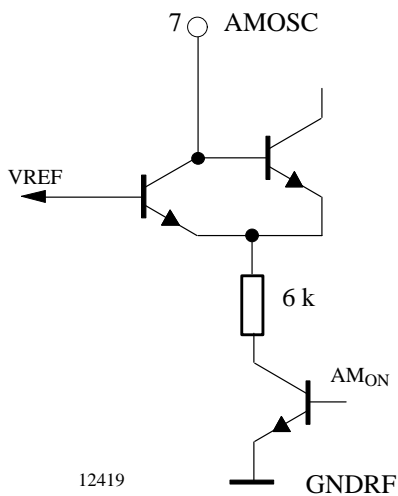

Figure 7.

The AM oscillator has to be loaded by an external tank referred to VREF (Pin 14). If reduction of the oscillator voltage is necessary, this may be achieved by a parallel resistor.

AMSADJ

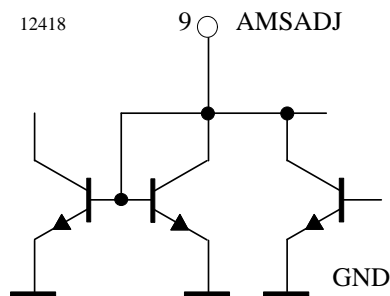

Figure 8.

The ceramic resonator of the stereo decoder PLL circuit is used as a stop signal detector for AM signals. For this purpose, the parallel resonance frequency of the resonator, which is unloaded about 456 kHz, is reduced by an internal load capacitor down to 455 kHz. Therefore, the AM IF must be 455 kHz. The internal loading capacitor is defined by the current through AMSADJ (Pin 9) to GND. An external resistor is connected between AMSADJ (Pin 9) and GND. It allows the alignment of the stop signal center frequency. The width of the stop window is typically 800 Hz. If AM search-mode is not activated, the pin is internally pulled to ground.

IFOUT

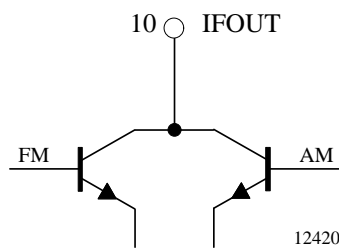

Figure 9.

The IF output (IFOUT Pin 10) of both the FM and the AM mixer has to be loaded into external IF-tank circuits referred to VREF (Pin 14). Q-factor of IF coils must not be lower than 50.

AMIFIN

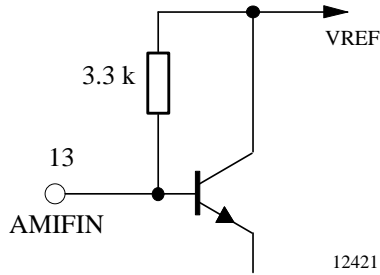

Figure 10.

The input impedance of the AM IF amplifier is 3.3 kΩ according to the required impedance of most ceramic filters. The input refers to VREF (Pin 14).

FMDET

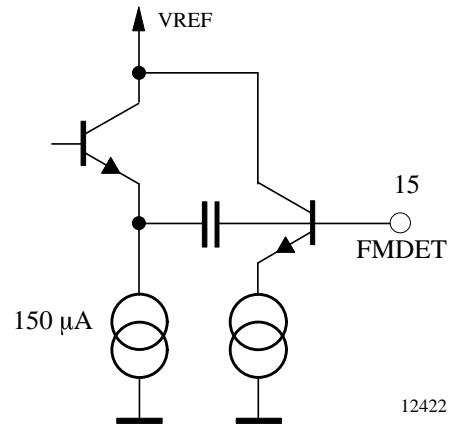

Figure 12.

The discriminator allows the connection of a ceramic resonator or LC tank. A minimization of THD and adjustment of center frequency versus temperature can only be achieved by using a LC tank. This performs a temperature independent stop signal.

FMIFIN

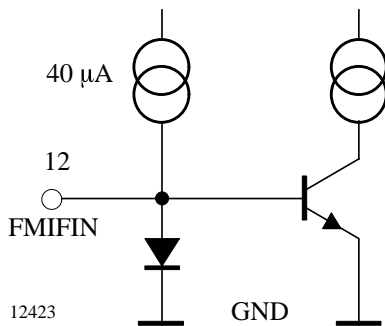

Figure 11.

The input impedance of the FM IF amplifier is 330 Ω according to the required impedance of most FM ceramic filters. The input refers to GND (Pin 16).

AFSM

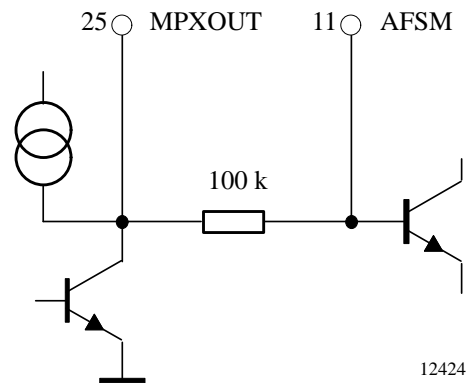

Figure 13.

A capacitor is connected between AFSM (Pin 11) and GND for smoothing of the FM-AF. This is necessary to generate a modulation independent stop signal. (Because the deviation of the FM signal (75 kHz) can be greater than the stop signal window (25 kHz)). In the AM-search-mode, the external capacitor smoothes the demodulated AM-IF-signal.

METER

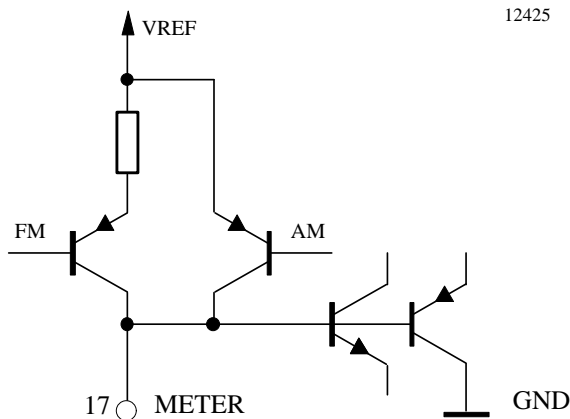

Figure 14.

This pin is driven by a current corresponding to the level of the FM or AM-IF-signal. The required external load consists of a resistor (100 to 150 kΩ) in parallel with an external capacitor (e.g., 10 μF necessary to achieve a good THD in AM mode and to suppress AF influence in FM mode). The voltage at this pin controls the high cut and mono/ stereo blend function in the case of reception mode. These functions can be affected by the designer by choosing different values of the load resistor.

CTRLA

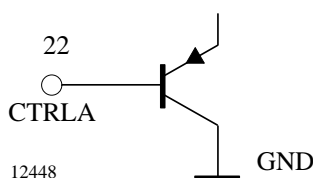

Figure 15.

The reception mode, search mode, as well as mute function and search sensitivity can be selected by applying a control voltage at CTRLA (Pin 22). If the control voltage is higher than 0.8 V, the receiver circuit is in the reception mode, otherwise it is in search mode. When reducing the control voltage between 1.3 and 0.8 V, the AF level output at OTR, OUTL (Pin 18, 19) is reduced (mute function). In the search mode (0.7 to 0 V), the voltage size determines the degree of the search sensitivity.

CTRLB

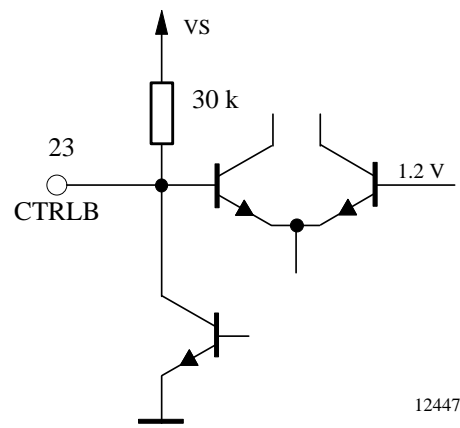

Figure 16.

The signal at the output CTRLB (Pin 23) shows stereo or mono reception. The stereo reception is indicated if the voltage is higher than 1.2 V, otherwise it is mono. Furthermore there is the possibility to force the receiver circuit to mono by applying an external control voltage <0.8 V at CTRLB. If the search mode is selected, the low active stop signal appears at CTRLB. If the output CTRLB is connected directly to the I/O-port of the microcontroller, the high level of CTRLB has to be adapted by connecting a resistor between CTRLB and GND.

VREF

An internal voltage regulator generates a stable reference voltage of 2.4 V which is needed for all function blocks of the IC. An external capacitor has to be connected to GND in order to achieve stability and noise suppression.

AMFM

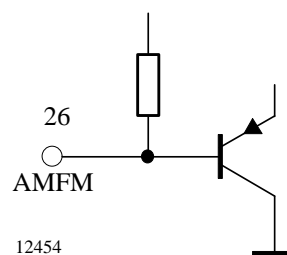

Figure 17.

By applying a low voltage (<1.1 V) at AMFM (Pin 26), the receiver circuit is switched to AM mode. If Pin AMFM is open, the FM mode is selected. This switching function can easily be performed by a microcontroller with "open drain" I/O-ports. A capacitor has to be connected between AMFM and GND for FM mode operation. It serves for smoothing the control voltage of the pilot canceller.

CERES

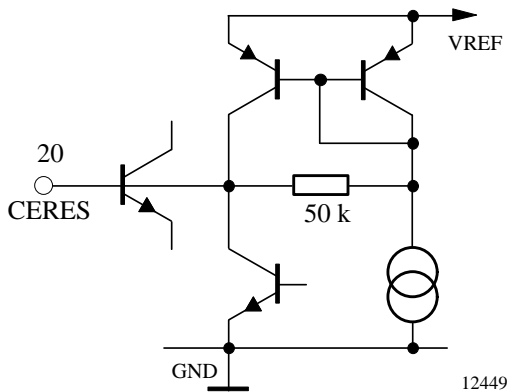

Figure 18.

A ceramic resonator of 456 kHz parallel resonance frequency (at 30 pF chip internal load capacitance) is connected between CRES (Pin 20) and GND (necessary for the pilot regeneration). It should be mounted very close to Pin 20 in order to avoid spurious radiation. In the AM ($V_{26} < 1.1\text{ V}$) search ($V_{22} < 0.8\text{ V}$) mode, the resonator is used for stop signal generation. The parallel resonance frequency is then reduced down to 455 kHz by adjusting the current into Pin 9 AMSADJ.

LPF

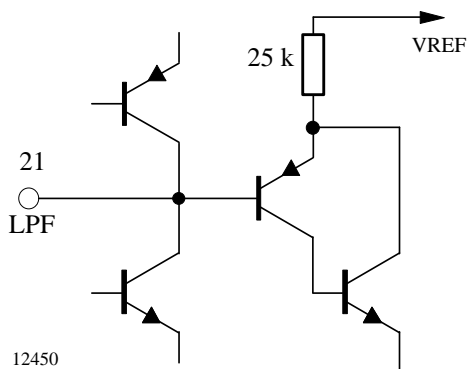

Figure 19.

A PLL circuit is used for the pilot regeneration of the stereo decoder. Therefore, a loopfilter consisting of an RC network is connected between LPF (Pin 21) and GND.

MPXIN

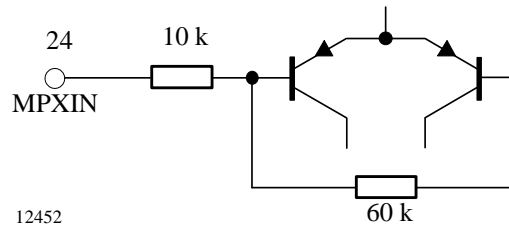

Figure 20.

The MPX signal is applied to MPXIN (Pin 24). It is fed to the stereo decoder. The input resistance into Pin 24 is approximately 10 kΩ. It is recommended to align the channel separation by an RC network between MPXIN and MPXOUT (Pin 25) due to the tolerances in group delay of the IF filter.

MPXOUT

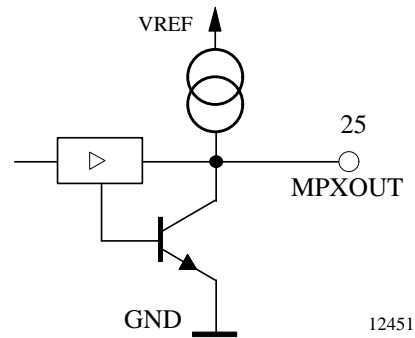

Figure 21.

In order to drive both the compensation network to MPXIN (Pin 24) and an optional RDS decoder, the MPXOUT (Pin 25) has a low output impedance. The dc level is 1.2 V in FM mode (depending on the discriminator coil alignment) and 0.7 to 1.5 V in AM mode (depending on the signal level).

OUTR/OUTL

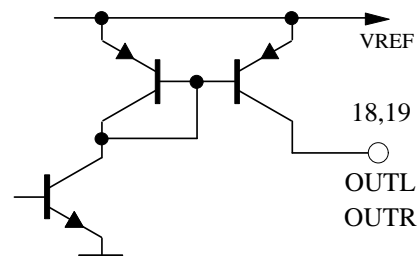

Figure 22.

The open collector output of OUTR/OUTL (Pin 18/19) requires an external resistor of about 4.7 kΩ to ground. The de-emphasis may be achieved by an additional parallel capacitor.

Functional Description

FM

The antenna signal is fed via a tuned RF-circuit to the integrated pre-stage which consists of a transistor grounded base circuit. To protect the prestage against overload, an automatic gain control (AGC) is included on the chip. Additional there is the possibility to extend the AGC control range by use of an external pin diode. For economic applications a hybrid-band pass filter can be used instead of a tuned RF-circuit.

A tuned RF circuit on the collector is necessary for amplifying and filtering of the FM signal which is fed internally to the mixer. It consists of a double balanced Gilbert Cell.

The LO signal is generated by an integrated oscillator. The buffered LO signal is used to drive a PLL. The IF-signal (10.7 MHz) is coupled out at the mixers output and fed via a ceramic filter to the demodulator. The demodulated AF signal is available at MPXOUT.

AM

The antenna signal is fed directly to the mixer. In order to ensure the level control which is necessary in the case of large signals, the generator resistance has to be higher than 25 kΩ. The LO signal is generated by an integrated oscillator. The buffered LO signal is used to drive the PLL. If the AM-search mode is required, the IF must be 455 kHz. The IF output signal is fed via a ceramic filter to the demodulator. The demodulated AF signal is available at MPXOUT.

CTRLA

By applying a control voltage at pin CTRLA the mode of the receiver can be selected.

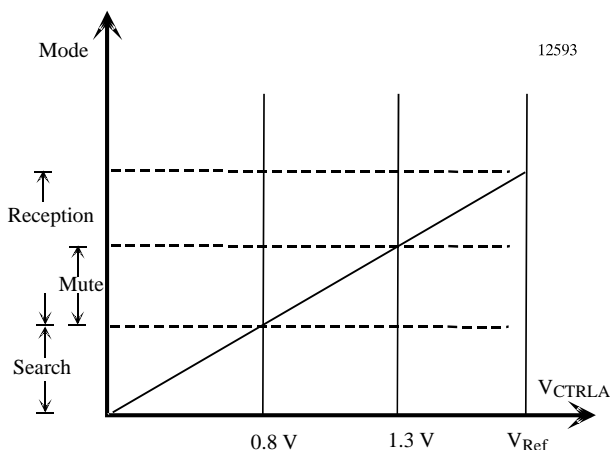

Figure 23.

Search Mode

The search-mode is selected by applying a control voltage less than 0.7 V at pin CTRLA.

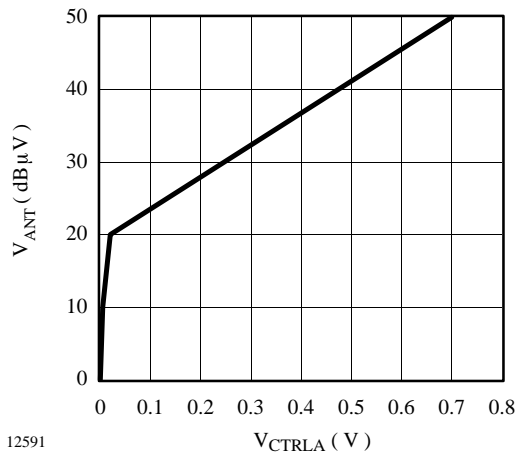

Figure 24.

The search sensitivity can be chosen by varying of the control voltage in the range of 0 to 0.7 V. If the control voltage is 0 V, the highest sensitivity is achieved.

Reception Mode

In the reception-mode there is a possibility for muting by varying the control voltage in the range of 1.3 to 0.8 V. If the control voltage is 0.8 V, the highest mute depth is achieved.

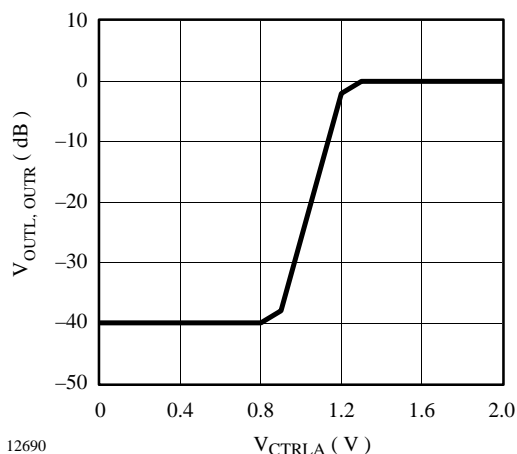

Figure 25.

CTRLB

The output CTRLB indicates whether the receiver is working in mono or stereo mode.

If a control voltage less than 0.8 V is applied at CTRLB, the receiver is forced to mono.

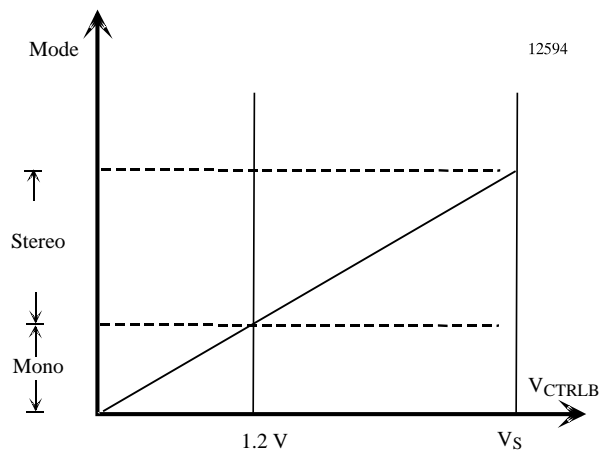

Figure 26.

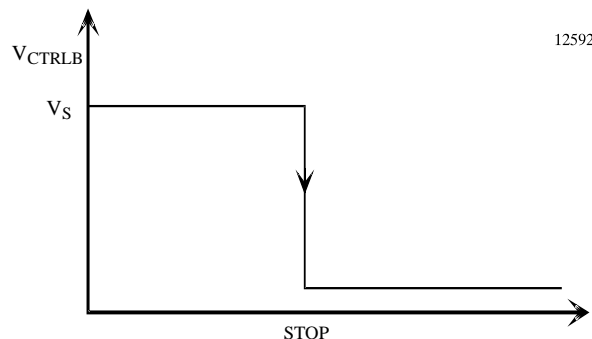

Figure 27.

In the search mode ($V_{CTRLA} < 0.7$ V), the internally generated stop signal is available at CTRLB as low active signal.

Absolute Maximum Values

Reference point Pin 16 and 4, unless otherwise specified

Parameters	Symbol	Value	Unit
Supply voltage	V_S	12	V
Power dissipation	P	750	mW
External reference current to GND	I_{Load}	3	mA
Junction temperature	T_j	+125	°C
Storage temperature	T_{stg}	-25 to +125	°C
Ambient temperature	T_{amb}	-30 to +85	°C
Electrostatic handling	$\pm V_{ESD}$	2000	V

Thermal Resistance

Parameters	Symbol	Value	Unit
Junction ambient when soldered to PCB	R_{thJA}	tbd.	K/W

Electrical Characteristics

$V_S = 9\text{ V}$, $T_{\text{amb}} = +25^\circ\text{C}$; reference point Pins 4 or 16, unless otherwise specified

Parameters	Test Conditions / Pins	Symbol	Min.	Typ.	Max.	Unit
DC supply						
Supply voltage range	Pin 27	V_S	3.0		12.0	V
Supply current	Pin 27	I_S		8		mA
Reference voltage	Pin 14	V_{Ref}	2.3	2.4	2.5	V
CTRLA						
Input voltage	Pin 22	V_{CTRLA}				
Search mode			0		0.7	V
Reception mode			0.8		V_{Ref}	V
Mute function			0.8		1.3	V
CTRLB						
Output voltage	Reception mode	V_{CTRLB}				
Mono	$V_{\text{CTRLA}} > 0.8\text{ V}$ Pin 23		0		1.2	V
Stereo			1.2		V_S	V
Stop signal	Search mode	V_{CTRLB}				
High	$V_{\text{CTRLA}} < 0.8\text{ V}$		1.5		V_S	V
Low			0		0.6	V
Stop window (FM)		f		20		kHz
Stop window (AM)	$f_{\text{center}} = 455\text{ kHz}$ adjusted at AMSADJ	f		1		kHz
Input voltage		V_{CTRLB}	0		0.8	V
Forced mono						
AMFM						
Input voltage	Pin 26	V_{AMFM}				
AM			0		1.1	V
FM	open					
OSCOUT						
Output voltage	Pin 8	V_{OSCOUT}				
AM				120		mVrms
FM	$f_{\text{LO}} = 110\text{ MHz}$, unloaded			150		mVrms
DC-current (FM)		I_{OSCOUT}		0.7		mA
METER						
Starting point meter (FM)	Pin 17	v_{start}		5		μV
Slope of meter (FM)	$R_{17} = 150\text{ k}\Omega$ Pin 17	v_{slope}		0.04		V/dB
Usable meter range (FM)	Pin 17			48		dB
DC-output voltage (AM)	See AM test circuit, Pin 17	V_{METER}				
	$V_{\text{RF}} = 0\text{ dB}\mu\text{V}$			0.05		V
	$V_{\text{RF}} = 40\text{ dB}\mu\text{V}$			0.7		V
	$V_{\text{RF}} = 100\text{ dB}\mu\text{V}$			1.8		V

Parameters	Test Conditions / Pins	Symbol	Min.	Typ.	Max.	Unit
MPXOUT						
Output voltage (AM)	See AM test circuit $f_{RF} = 1 \text{ MHz}$, $m = 0.3$, $f_{mod} = 1 \text{ kHz}$, $R_{gen} = 25 \text{ k}\Omega$, $V_{CTRLA} = 1.7 \text{ V}$, Pin 25					
	$V_{RF} = 20 \text{ dB}\mu\text{V}$	V_{MPXOUT}		35		mV_{rms}
	$V_{RF} = 40 \text{ dB}\mu\text{V}$			54		mV_{rms}
	$V_{RF} = 100 \text{ dB}\mu\text{V}$			66		mV_{rms}
Total distortion	$V_{RF} = 100 \text{ dB}\mu\text{V}$	d		0.7		%
Signal plus noise-to-noise	$V_{RF} = 40 \text{ dB}\mu\text{V}$	(S+N)/N		27		dB
	$V_{RF} = 100 \text{ dB}\mu\text{V}$			47		dB
Sensitivity (AM)	(S+N)/N = 26 dB			38		$\text{dB}\mu\text{V}$
Sensitivity (FM)	$f_0 = 98 \text{ MHz}$, deviation = $\pm 75 \text{ kHz}$, without de-emphasis (S+N)/N = 26 dB			4		μV
MPXIN						
Input resistance	Pin 24	R_{MPXIN}		10		$\text{k}\Omega$
Input voltage		V_{MPXIN}			900	mV_{pp}
OUTL, OTR						
AF output voltage	$\Delta f = \pm 75 \text{ kHz}$, $f_{mod} = 1 \text{ kHz}$, $V_{FMIN} = 1 \text{ mV}$, $f_{FMIN} = 97 \text{ MHz}$ Pin 18/19	V_{OUT}		110		mV_{rms}
Output current		I_{out}		15		μA
Muting attenuation		α_M		40		dB
Channel separation		α		26		dB
Pilot signal suppression		$\alpha_{19\text{kHz}}$		28		dB
CERES						
PLL oscillator frequency	$\Delta f = \pm 75 \text{ kHz}$, $f_{mod} = 1 \text{ kHz}$, Pilot $\Delta f = \pm 6.7 \text{ kHz}$ $V_{FMIN} = 1 \text{ mV}$, $f_{FMIN} = 97 \text{ MHz}$ Pin 20	f_{CERES}		456		kHz
FMRF						
DC-current	Pin 3	I_{FMRF}		1		mA
Voltage gain preamplifier	See FM test circuit $20 \times \log (v_{FMRF}/v_0)$	g_{FMRF}		16		dB
AGC threshold	3 dB compression at Pin 3	v_{0AGC}		5		mV
IFOUT						
DC-current	Pin 10	I_{IFOUT}		0.4		mA
Conversion gain	$20 \times \log (v_{IFOUT}/v_{FMRF})$	g_c		20		dB
FMIFIN						
Input resistance	Pin 12	r_{FMIFIN}		330		Ω

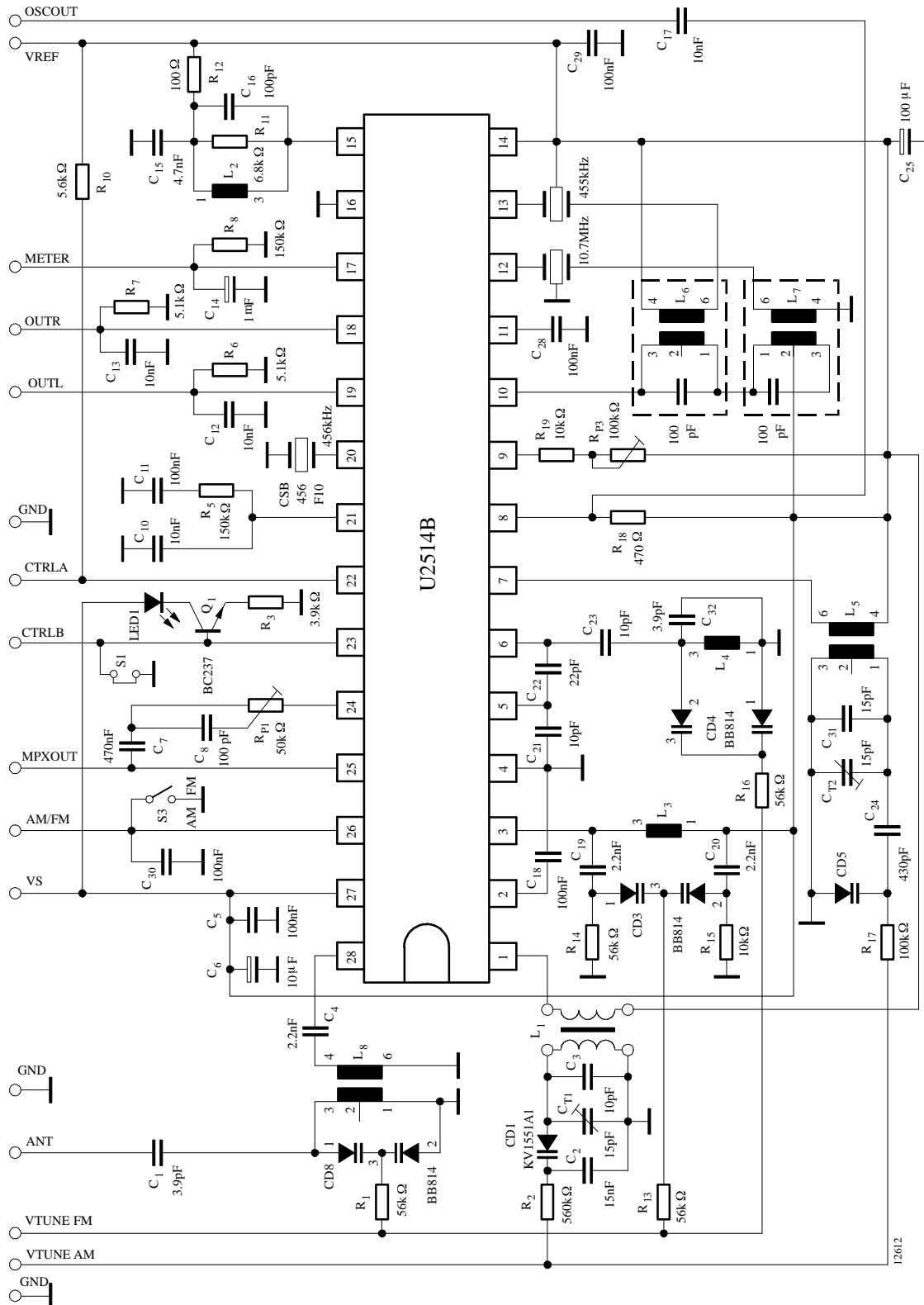

Figure 28. Application circuit

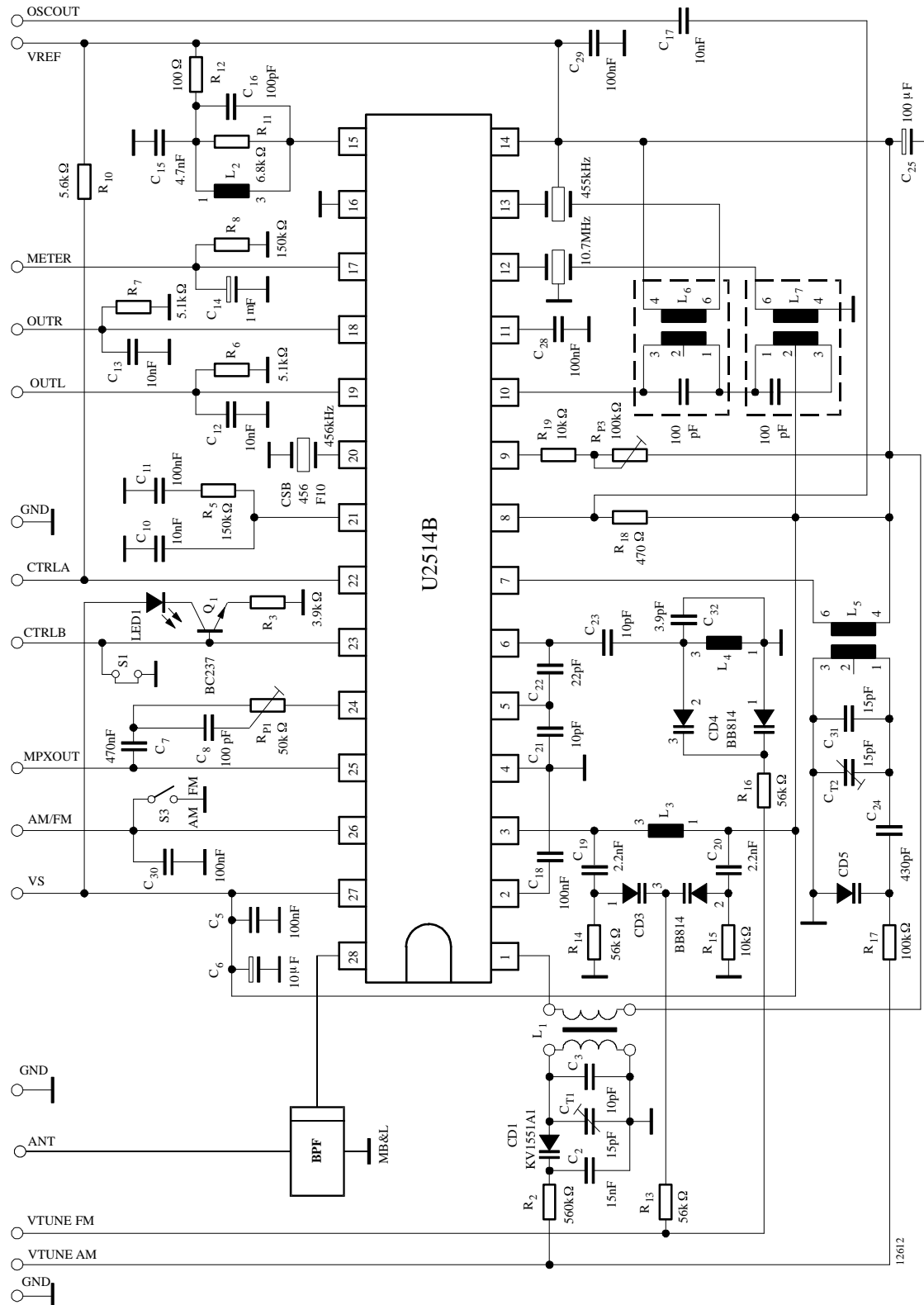
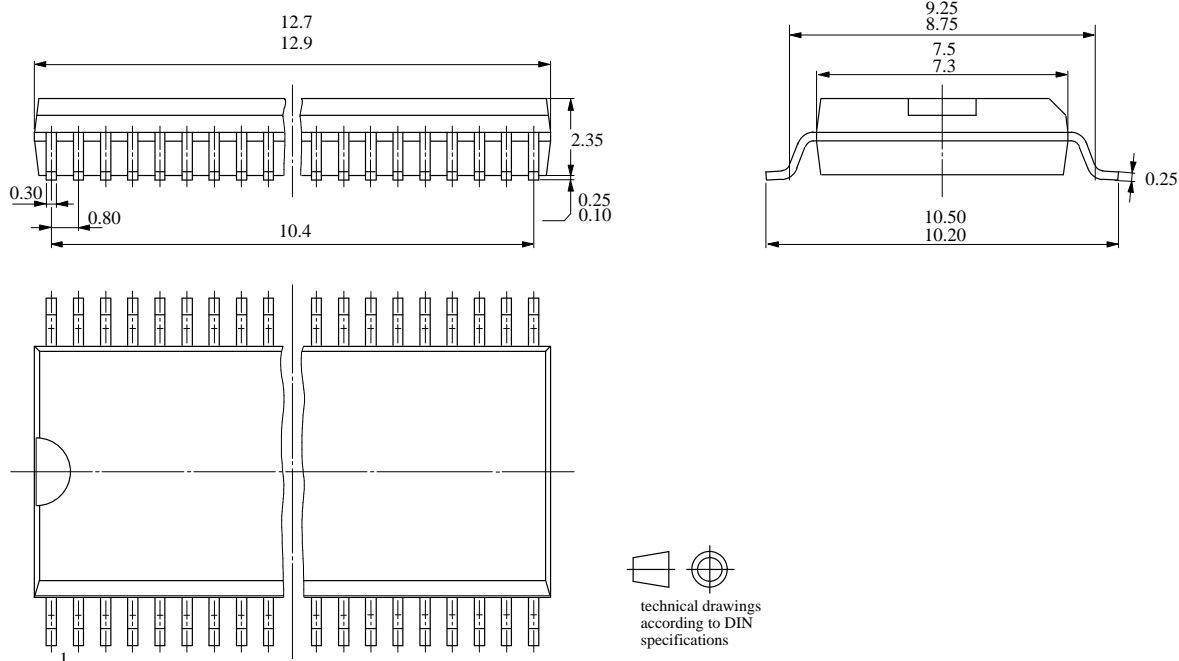

Figure 29. Application circuit (upgraded)

Dimensions in mm

Package: SSO28



Ozone Depleting Substances Policy Statement

It is the policy of **TEMIC TELEFUNKEN microelectronic GmbH** to

1. Meet all present and future national and international statutory requirements.
2. Regularly and continuously improve the performance of our products, processes, distribution and operating systems with respect to their impact on the health and safety of our employees and the public, as well as their impact on the environment.

It is particular concern to control or eliminate releases of those substances into the atmosphere which are known as ozone depleting substances (ODSs).

The Montreal Protocol (1987) and its London Amendments (1990) intend to severely restrict the use of ODSs and forbid their use within the next ten years. Various national and international initiatives are pressing for an earlier ban on these substances.

TEMIC TELEFUNKEN microelectronic GmbH semiconductor division has been able to use its policy of continuous improvements to eliminate the use of ODSs listed in the following documents.

1. Annex A, B and list of transitional substances of the Montreal Protocol and the London Amendments respectively
2. Class I and II ozone depleting substances in the Clean Air Act Amendments of 1990 by the Environmental Protection Agency (EPA) in the USA
3. Council Decision 88/540/EEC and 91/690/EEC Annex A, B and C (transitional substances) respectively.

TEMIC can certify that our semiconductors are not manufactured with ozone depleting substances and do not contain such substances.

We reserve the right to make changes to improve technical design and may do so without further notice.

Parameters can vary in different applications. All operating parameters must be validated for each customer application by the customer. Should the buyer use TEMIC products for any unintended or unauthorized application, the buyer shall indemnify TEMIC against all claims, costs, damages, and expenses, arising out of, directly or indirectly, any claim of personal damage, injury or death associated with such unintended or unauthorized use.

TEMIC TELEFUNKEN microelectronic GmbH, P.O.B. 3535, D-74025 Heilbronn, Germany
Telephone: 49 (0)7131 67 2831, Fax number: 49 (0)7131 67 2423

Copyright © Each Manufacturing Company.

All Datasheets cannot be modified without permission.

This datasheet has been download from :

www.AllDataSheet.com

100% Free DataSheet Search Site.

Free Download.

No Register.

Fast Search System.

www.AllDataSheet.com