

Intermittent- and Wipe/Wash Control for Wiper Systems

Description

With the U264xB, TEMIC Semiconductors developed a family of intermittent- and wipe/wash control circuits for windshield or backlite wiper systems with identical basic functions. The circuit design provides the possibility to

generate "x" versions using different metallization masks. Thus, it is easy to verify a broad range of time sequences which can be set independently of each other.

Features

- Relay activation can be controlled by a limit switch of the wiper motor or by a fixed activation period for systems without limit switch
- Debounced input stages
- Enable/disable of pre-wash delay by program pin
- Polarity of WIWA: V_{Batt}
- Polarity of INT: V_{Batt}
- Relay output is protected with a clamping diode
- Relay activation: 0.64 s
- Interval pause: 10 s
- After wiping: 5.8 s
- Pre-wash delay: 0.91 s
- Wipe/wash mode with priority
- Protected in accordance to ISO/TR 7637-1
- EMC with intergrated filters

Ordering Information

Extended Type Number	Package	Remarks
U2642B	DIP8	
U2642B-FP	SO8	

Block Diagram

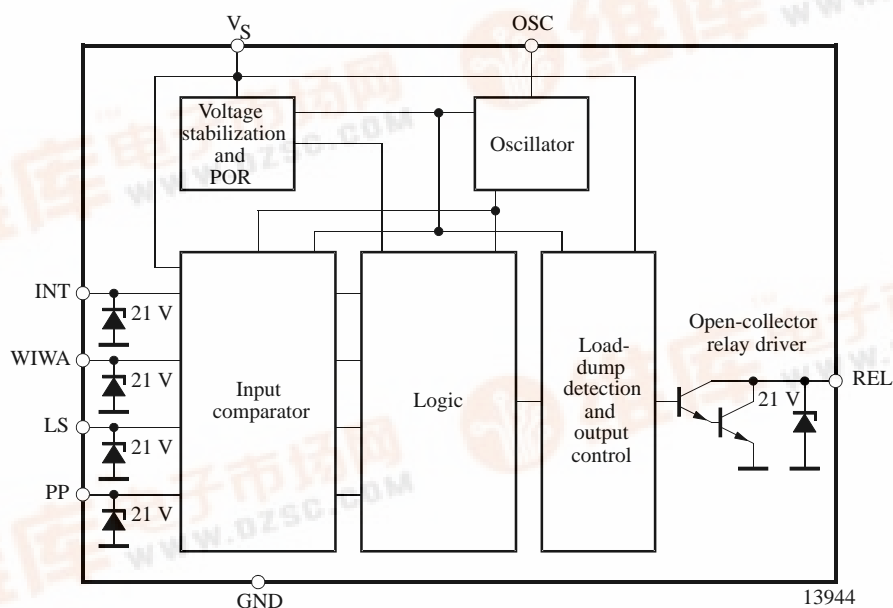
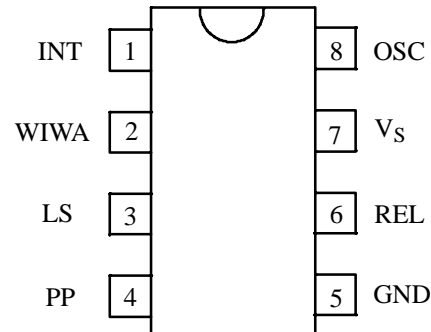

Figure 1.



Pin Configuration

Pin	Symbol	Function
1	INT	Intermittent input
2	WIWA	Wipe/wash (WIWA) input
3	LS	Limit switch (wiper motor) input
4	PP	Program pin
5	GND	Ground
6	REL	Relay output
7	V _S	Supply voltage
8	OSC	RC oscillator input



13365

Figure 2. Pinning

Functional Description

All times specified below refer to an oscillator frequency of 200 Hz. Figures 2 to 9 show the dependencies of the times upon battery voltage and temperature. The temperature dependence of the oscillator frequency is essentially determined by the temperature coefficient of the oscillator capacitor. The temperature dependence of the oscillator frequency can be reduced to minimum with a slightly negative temperature coefficient (N100). The capacitor used in figures 10 and 11 has a slightly positive temperature coefficient.

All times are permanently set and can be changed only jointly within certain limits by adjusting the oscillator frequency. See table 1.

Intermittent Function

The relay is energized for the time t_{ON} after the switch INT is switched on with respect to V_{Batt} and after expiration of time t_D (debounce).

The debounce time ranges between 60 ms and 80 ms. A time period of 5 ms to 40 ms for internal sequence control must be added (asynchronism between operating instant and internal clock) e.g., the response time may range from 65 ms up to 120 ms.

If the limit switch of the windscreen wiper motor is connected to Pin LS, the relay is energized as long as the switch is at high potential, regardless of the relay on-time, t_{ON} , i.e., the motor current in interval mode flows via the relay contact only. In park position, the motor winding at both ends is connected to ground via the limit switch and the motor is decelerated immediately. The limit switch input is debounced with $t_{DL} = 17$ ms.

The relay on-time, t_{ON} , always elapsed – even if the interval switch was opened beforehand.

Interval Pause

The interval pause $t_{INT} = 10$ s follows t_{ON} . Opening of switch INT causes a debounce time, t_D , and reclosing results in the relay on-time, t_{ON} , after t_D .

Wipe/Wash Function without Pre-Wash Delay (PP connected to GND)

The water pump is switched on when the switch WIWA is pressed and, after the debounce time, t_D , the relay is energized. After-wiping time $t_{AW} = 5.8$ s starts as soon as switch WIWA is opened and the debounce time, t_D , has expired. If the limit switch is connected, the relay remains energized until the wiper arm returns to park position, i.e., the motor current flows via the relay contact only.

Wipe/Wash Function with Pre-Wash Delay (PP connected to V_S)

In wipe/wash mode, the relay is energized after a delay time. The water pump can spray water onto the windscreen during the delay time, t_{DEL} .

The on-delay time of the U2641B is:

$$t_{DEL} = t_D + 0.84 \text{ s} = 0.91 \text{ s}$$

If switch WIWA is closed longer than t_D but shorter than t_{DEL} , the after-wiping time, t_{AW} , starts after expiration of t_{DEL} . The wipe/wash function with or without on-delay t_{DEL} can be selected by programming PP.

PP connected to GND: without pre-wash delay
PP connected to V_S: with pre-wash delay

The after-wiping time, t_{AW} , is re-triggerable in both cases.

Intermittent and Wipe/Wash Mode

The wipe/wash function has priority over the interval function. If switch WIWA is closed during the interval

function, wipe/wash mode is activated immediately after the debounce time, t_D , even if an on-delay is programmed ($t_{DEL} = 0$ s). Expiry of t_{AW} is directly followed by the next relay on-time, t_{ON} , of intermittent mode.

Oscillator

All timing sequences are derived from an RC-oscillator whose charging time, t_1 , is determined by an external resistor R_{OSC} and whose discharging time, t_2 , is determined by an integrated 2-k Ω resistor. Since tolerance and temperature response of the integrated resistor are far higher than those of the external resistor, t_1/t_2 must be selected to be greater than 20 for stability reasons. The minimum value of R_{OSC} should not be less than 68 k Ω .

Calculating cycle duration and frequency:

$$t = t_1 + t_2 = C_{OSC} \times (0.74 \times R_{OSC} + 2260 \Omega)$$

and $f_{OSC} = 1/t$

Calculating the capacitor for a given resistor:

$$C_{OSC} = t / (0.74 \times R_{OSC} + 2260 \Omega)$$

Calculating the oscillator resistance for a given capacitor:

$$R_{OSC} = 1.34 \times (t / C_{OSC} - 2260 \Omega)$$

Recommended frequency: $f_{OSC} = 200$ Hz
(for $R_{OSC} = 200$ k Ω , $C_{OSC} = 33$ nF)

All times can be varied jointly within specific limits by varying the oscillator frequency (see table 1). The oscillator is operable up to 50 Hz.

Power Supply

For reasons related to protection against interference and destruction, the Pin V_S must be provided with an RC network for limiting the current in the event of overvoltage and for buffering in the event of voltage drops.

Proposed ratings: $R_V = 510 \Omega$, $C_V = 47 \mu\text{F}$. An integrated 14-V Zener diode is connected between V_S and GND.

Interference Voltages and Load-Dump

In the case of transients, the integrated Zener diode limits the voltage of the relay output to approximately 28 V. In the case of load-dump, a current (dependent upon R_V and C_V) flows through the integrated 14-V Zener diode, and the relay output is switched on at $V_{Batt} > 30$ V in order to avoid destruction of the output. The output transistor is rated such that it can withstand the current generated during the load-dump through the relay coil. In practice, the windscreen wiper motor is switched on via the relay and thus the amplitude of the load-dump pulse is limited. The supply voltage of the circuit is limited to 14 V by the integrated Zener diode, and the inputs are protected by external protective resistors and integrated Zener diodes.

RF suppression is implemented with a low-pass filter at the inputs, consisting of a protective resistor and the integrated capacitor.

Power-on Reset (POR)

When the supply voltage is applied, a power-on reset pulse is generated which sets the circuit's logic to a defined initial state. The POR threshold is approximately $V_S = 4.3$ V.

Table 1. Change in times by varying the oscillator frequency

f_{OSC} (Hz)	t_D [ms]	t_{DL} [ms]	t_{ON} [ms]	t_{INT} [s]	t_{AW} [s]	t_{DEL} [s]
100	140	35	1280	20.0	11.6	1680
120	116	29	1066	17.0	9.6	1400
140	100	25	915	14.0	8.3	1200
160	87	22	800	12.5	7.2	1050
180	77	19	710	11.0	6.4	933
200	70	17	640	10.0	5.8	840
220	64	16	581	9.0	5.3	763
240	58	14	533	8.2	4.8	700
260	54	13	493	7.6	4.5	645
280	50	12	457	7.0	4.1	600
300	46	11	426	6.5	3.9	560
400	35	9	320	5.0	2.9	420

Absolute Maximum Ratings

With recommended external circuitry

Parameter	Test Conditions	Symbol	Value	Unit
Supply voltage (static)	5 min	V_{Batt}	24	V
Supply current pulse	2 ms	I_S	1.5	A
Supply current pulse	300 ms	I_S	150	mA
Relay output current (static)		I_{REL}	300	mA
Relay output current pulse	300 ms	I_{REL}	1.5	A
Ambient temperature range		T_{amb}	-40 to +95	°C
Storage temperature range		T_{stg}	-55 to +125	°C
Power dissipation	DIP8	P_{tot}	0.45	W
Power dissipation	SO8	P_{tot}	0.34	W

Thermal Resistance

Parameters	Symbol	Value	Unit
Junction ambient DIP8	R_{thJA}	120	K/W
Junction ambient SO8	R_{thJA}	160	K/W

Electrical Characteristics

Reference point Ground GND, $T_{amb} = 25^\circ\text{C}$, $V_{Batt} = 13.5\text{ V}$, unless otherwise specified (see figures 11 and 12)

Parameters	Test Conditions / Pin	Symbol	Min	Typ	Max	Unit
Voltage supply						
Pin 7						
Supply voltage		V_{Batt}	6.0		16.0	V
Supply current		I_S	0.5	2.0	3.0	mA
Undervoltage threshold (POR)		V_S	3.0		5.1	V
Internal Z-diode		V_Z	13.5	14.0	16.2	V
Internal capacitor		C_S		15		pF
Series resistance		R_V		510		Ω
Filter capacitor		C_V		47		μF
Oscillator input OSC						
Pin 8						
Internal discharge resistor		R_{DIS}	1.3	2.0	3.2	k Ω
Lower switching-point voltage		V_{OSC}	$0.16 \times V_S$	$0.20 \times V_S$	$0.24 \times V_S$	V
Upper switching-point voltage		V_{OSC}	$0.55 \times V_S$	$0.60 \times V_S$	$0.65 \times V_S$	V
Input current	$V_{OSC} = 0\text{ V}$	$-I_{OSC}$			2	μA
Oscillator frequency		f_{OSC}	1	200	50 k	Hz
Input limit switch LS						
Pin 3						
Internal protection-diode voltage	$I_{LS} = 10\text{ mA}$	V_{LS}	19.5	21.0	25.5	V
Internal capacitor		C_{LS}		25		pF
Switching threshold voltage		V_{LS}	$0.375 \times V_S$	$0.5 \times V_S$	$0.675 \times V_S$	V
Input current	$V_{LS} = V_S$	I_{LS}			1	μA
Internal pull-up resistor		R_{LS}	13	20	27	k Ω
External protection resistor		R_S	10			k Ω

Parameters	Test Conditions / Pin	Symbol	Min	Typ	Max	Unit
Inputs INT, WIWA and PP Pins 1, 2 and 4						
Internal protection-diode voltage	$I_E = 10 \text{ mA}$	V_E	19.5	21.0	25.5	V
Internal capacitor		C_E		25		pF
Switching threshold voltage		V_E	$0.375 \times V_S$	$0.5 \times V_S$	$0.675 \times V_S$	V
Input current	$V_E = 0 \text{ V}$	$-I_E$			1	μA
Internal pull-down resistor		R_E	13	20	27	$\text{k}\Omega$
External protection resistor		R_S	10			$\text{k}\Omega$
Relay Output Pins 6						
Saturation voltage	$I = 100 \text{ mA}$	V_{REL}			1.1	V
Saturation voltage	$I = 200 \text{ mA}$	V_{REL}			1.5	V
Z-diode clamp voltage	$I = 10 \text{ mA}$	V_{REL}	19.5	21.0	25.5	V
Leakage current	$V = 14 \text{ V}$	I_{REL}			12	μA
Relay coil resistance		R_{REL}	60			Ω
Load-dump protection threshold		V_{Batt}	28	33	42	V
Internal pulse times						
Debouncing period inputs	INT/WIWA 12 - 16 clocks	t_D	60	70	80	ms
Debouncing period inputs	LS 3 - 4 clocks	t_{DL}	15	17.5	20	ms
Relay activation time	96 clocks	t_{ON}		480		ms
Intermittent pause		t_{INT}		5.92		s
After wiping period	1024 ± 68 clocks	t_{WIWA}	4.78		5.46	s
Pre-wash delay reaction time for switch-on delay = $t_{DEL} + t_D$	88 - 96 clocks	t_{DEL}	440		480	ms

Note: All internally generated time sequences are derived from the oscillator frequency. The tolerances refer to a frequency adjusted to $f_{OSC} = 200 \text{ Hz}$.

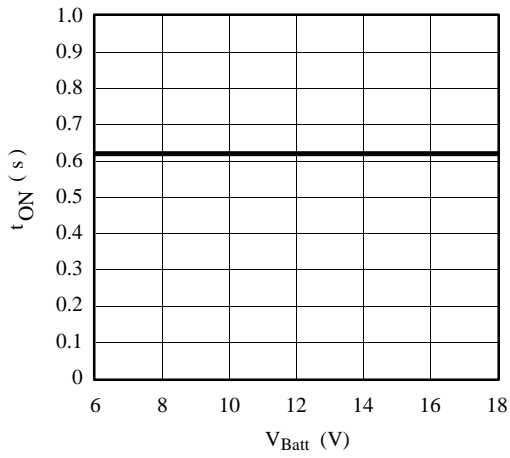

Figure 3. Relay activation = $f(V_{Batt})$

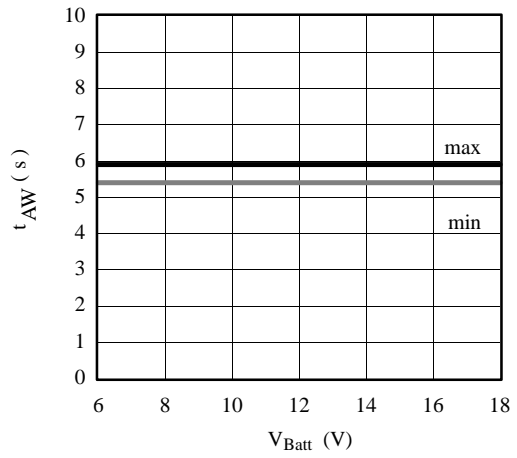

Figure 5. After-wipe time = $f(V_{Batt})$

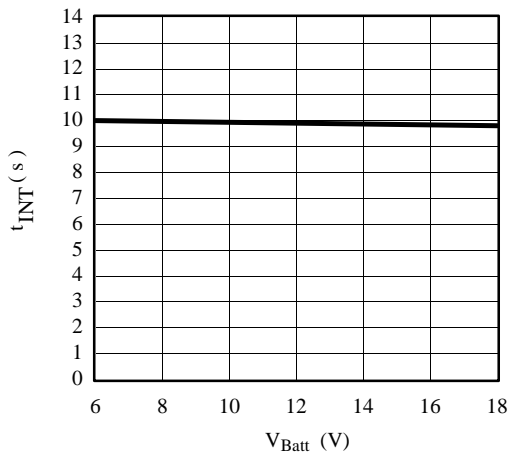

Figure 4. Interval pause = $f(V_{Batt})$

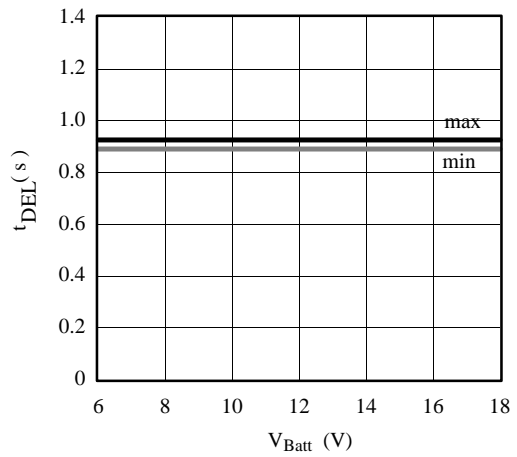

Figure 6. Pre-wash delay = $f(V_{Batt})$

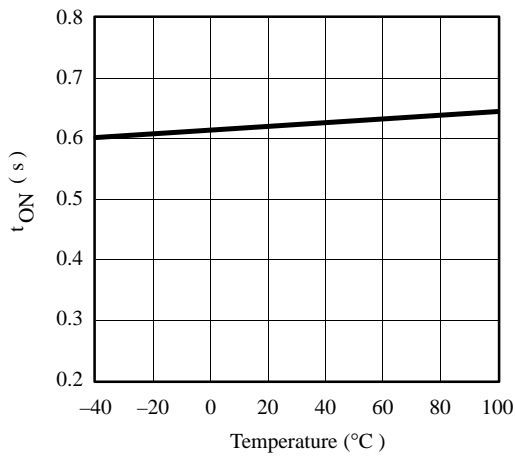

Figure 7. Relay activation = f (Temperature)

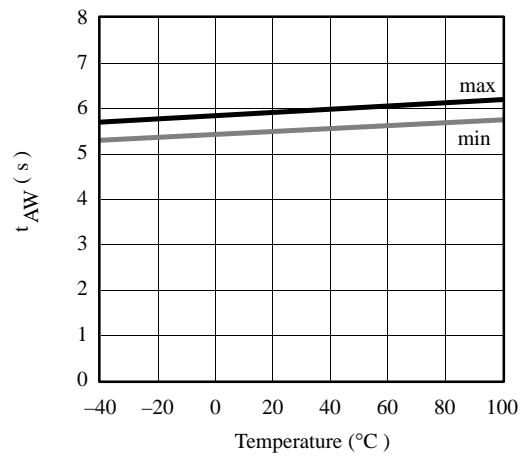

Figure 9. After-wipe time = f (Temperature)

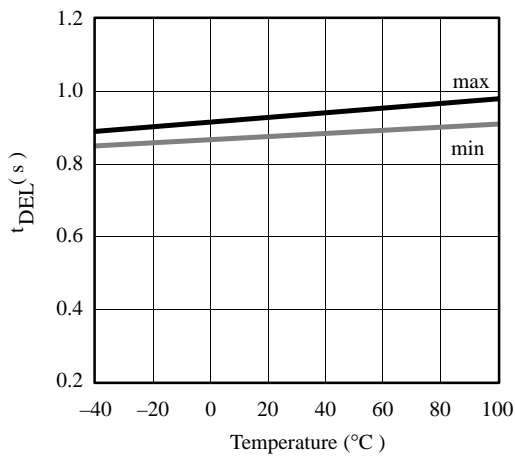

Figure 8. Pre-wash delay = f (Temperature)

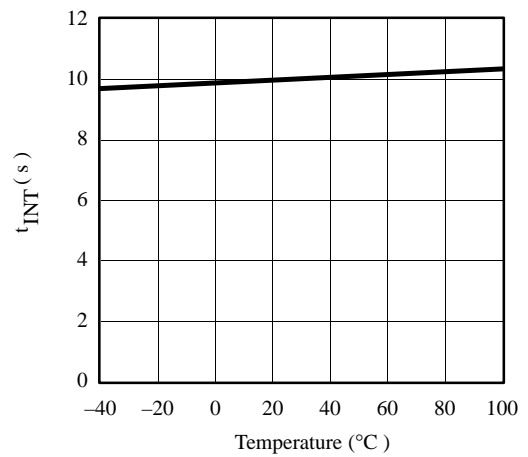

Figure 10. Interval pause = f (Temperature)

Note: The temperature characteristic is caused by the temperature coefficient T_C of the external capacitor

Application Examples

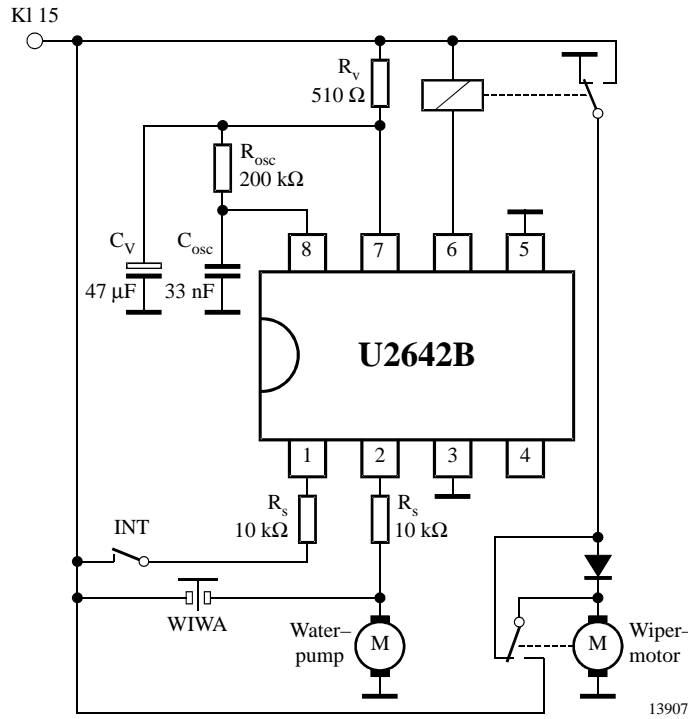

Figure 11. Application without limit switch

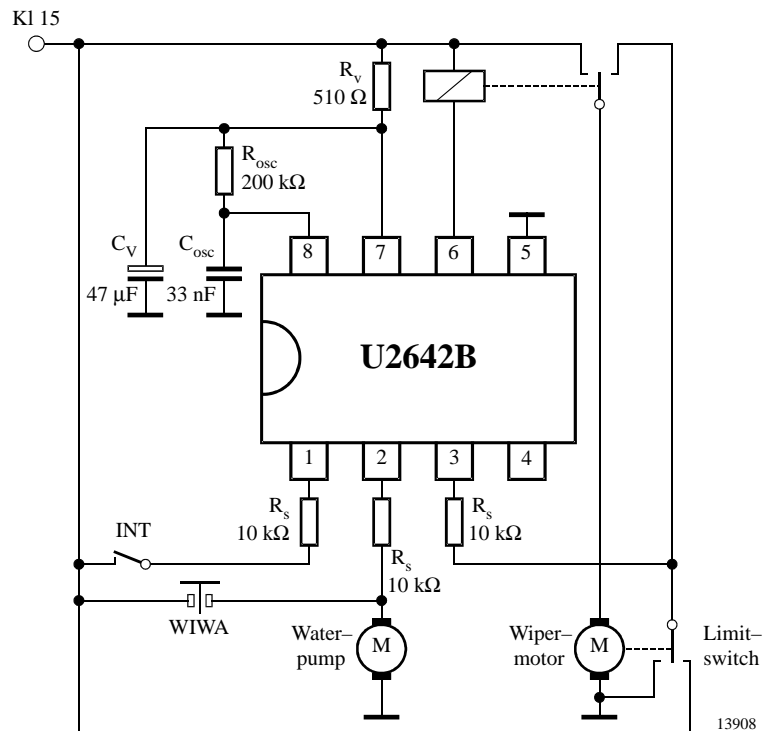
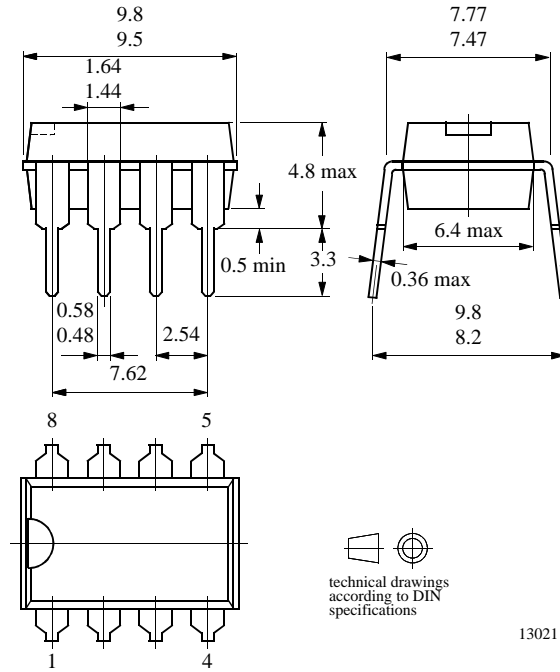

Figure 12. Application with limit switch

Package Information

Package DIP8

Dimensions in mm



Package SO8

Dimensions in mm

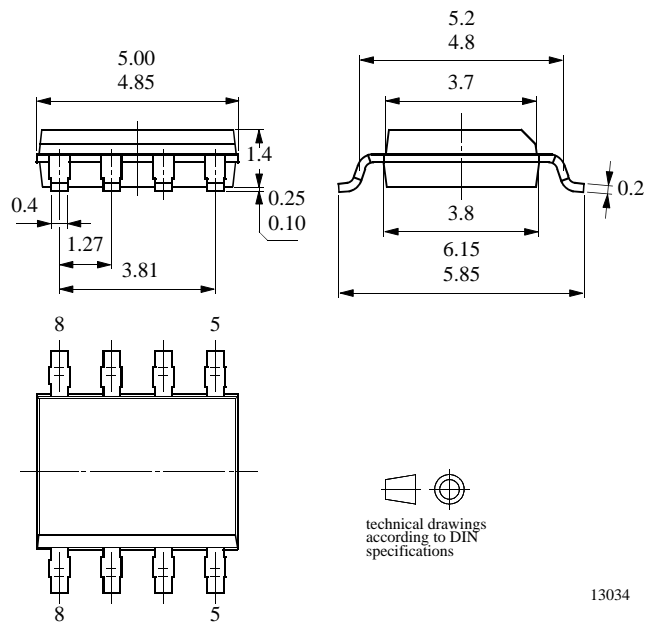

Ozone Depleting Substances Policy Statement

It is the policy of **TEMIC TELEFUNKEN microelectronic GmbH** to

1. Meet all present and future national and international statutory requirements.
2. Regularly and continuously improve the performance of our products, processes, distribution and operating systems with respect to their impact on the health and safety of our employees and the public, as well as their impact on the environment.

It is particular concern to control or eliminate releases of those substances into the atmosphere which are known as ozone depleting substances (ODSs).

The Montreal Protocol (1987) and its London Amendments (1990) intend to severely restrict the use of ODSs and forbid their use within the next ten years. Various national and international initiatives are pressing for an earlier ban on these substances.

TEMIC TELEFUNKEN microelectronic GmbH semiconductor division has been able to use its policy of continuous improvements to eliminate the use of ODSs listed in the following documents.

1. Annex A, B and list of transitional substances of the Montreal Protocol and the London Amendments respectively
2. Class I and II ozone depleting substances in the Clean Air Act Amendments of 1990 by the Environmental Protection Agency (EPA) in the USA
3. Council Decision 88/540/EEC and 91/690/EEC Annex A, B and C (transitional substances) respectively.

TEMIC can certify that our semiconductors are not manufactured with ozone depleting substances and do not contain such substances.

We reserve the right to make changes to improve technical design and may do so without further notice.

Parameters can vary in different applications. All operating parameters must be validated for each customer application by the customer. Should the buyer use TEMIC products for any unintended or unauthorized application, the buyer shall indemnify TEMIC against all claims, costs, damages, and expenses, arising out of, directly or indirectly, any claim of personal damage, injury or death associated with such unintended or unauthorized use.

TEMIC TELEFUNKEN microelectronic GmbH, P.O.B. 3535, D-74025 Heilbronn, Germany
Telephone: 49 (0)7131 67 2831, Fax number: 49 (0)7131 67 2423