

TEMIC

TELEFUNKEN Semiconductors

U2794B

1000 MHz Quadrature Demodulator

Description

U2794B silicon monolithic integrated circuit is a quadrature demodulator that is manufactured using TELEFUNKEN's advanced UHF technology. This demodulator features a frequency range from 70 – 1000 MHz, low current consumption, selectable

gain, power down mode and is adjustment free. The IC is suitable for direct conversion and image rejection applications in digital radio systems up to 1 GHz such as cellular radio, cordless telephone, cable TV and satellite TV systems.

Features

- Supply voltage 5 V (typ.)
- Very low power consumption 125 mW (typ.)
- Very good image rejection by means of phase control loop for precise 90° phase shifting
- Duty cycle regeneration for single ended LO input signal
- Low LO input level –10 dBm (typ.)
- LO – frequency from 70 MHz to 1 GHz
- Power down mode
- 25 dB gain control
- Very low I/Q output dc offset voltage typ. < 5 mV

Block Diagram

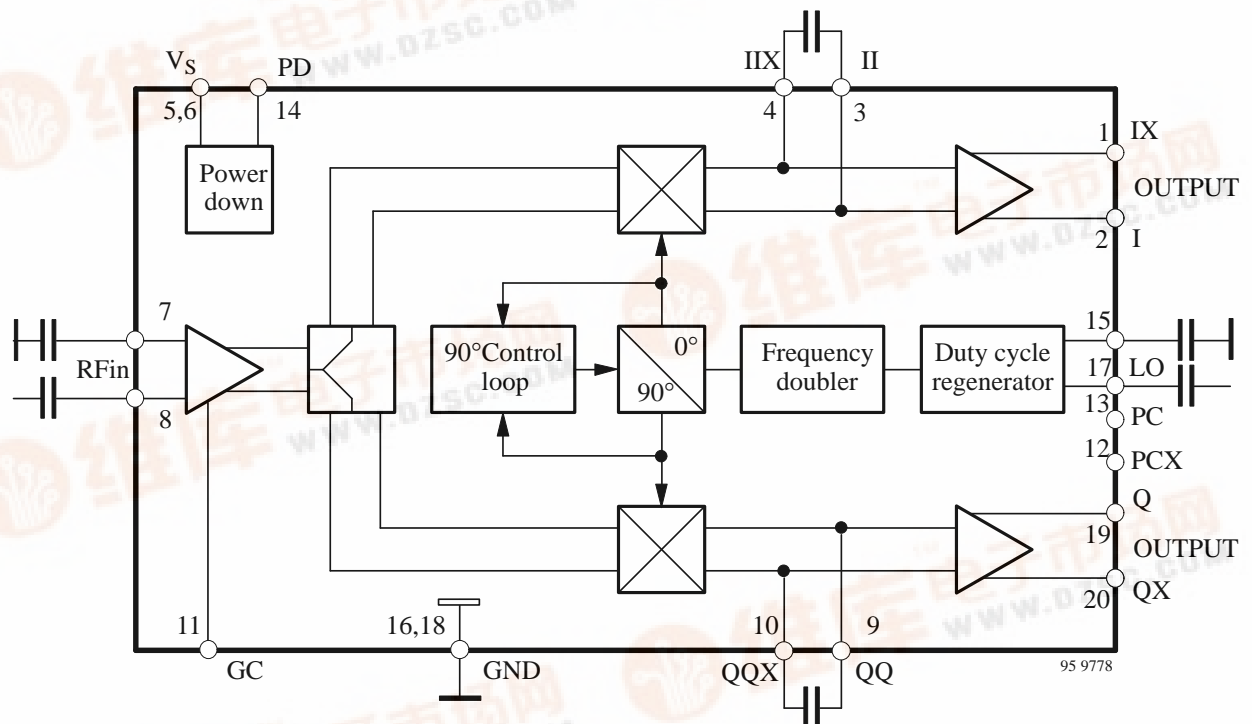

Ordering Information

Extended Type Number	Package	Remarks
U2794B-AFS	SSO 20	Rail, MOQ 830 pcs.
U2794B-AFSG3	SSO 20	Tape and reel, MOQ 4000 pcs.

Pin Description

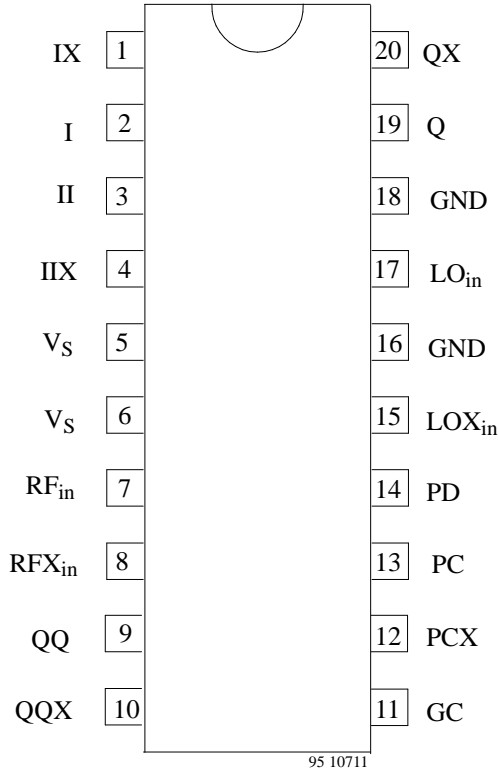

Pin	Symbol	Function
1	IX	IX output
2	I	I output
3	II	II low pass filter I
4	IIX	IIX low pass filter I
5	V _S	Supply voltage
6	V _S	Supply voltage
7	RF _{in}	RF input
8	RFX _{in}	RFX input
9	QQ	QQ low pass filter Q
10	QQX	QQX low pass filter Q
11	GC	GC gain control
12	PCX	PCX phase control
13	PC	PC phase control
14	PD	PD power down
15	LOX _{in}	LOX input
16	GND	Ground
17	LO _{in}	LO input
18	GND	Ground
19	Q	Q output
20	QX	QX output

Electrostatic sensitive device, observe precautions for handling!

Absolute Maximum Ratings

Parameters	Symbol	Value	Unit
Supply voltage Pins 5 and 6	V _S	6	V
Input voltage Pins 7, 8 and 17	V _i	0 to V _S	V
Junction temperature	T _j	125	°C
Storage temperature range	T _{stg}	-40 to 125	°C

Operating Range

Parameters	Symbol	Value	Unit
Supply voltage range Pins 5 and 6	V _S	4.75 to 5.25	V
Ambient temperature range	T _{amb}	-40 to 85	°C

Thermal Resistance

Parameters	Symbol	Value	Unit
Junction ambient SSO 20	R _{thJA}	140	K/W

Electrical Characteristics

Test conditions (unless otherwise specified); $V_S = 5\text{ V}$, $T_{\text{amb}} = 25^\circ\text{C}$, referred to test circuit
 System impedance $Z_O = 50\ \Omega$, $f_{\text{iLO}} = 950\text{ MHz}$, $P_{\text{iLO}} = -10\text{ dBm}$

Parameters	Test Conditions / Pins	Symbol	Min.	Typ.	Max.	Unit
Supply voltage range	Pins 5 and 6	V_S	4.75		5.25	V
Supply current	Pins 5 and 6	I_S		30		mA
Power down mode, PD						
“OFF”mode supply current	$V_{\text{PD}} \leq 0.5\text{ V}$ Pins 5 and 6 $V_{\text{PD}} = 1.0\text{ V}$ Pin 14 Note 1	I_{SPD}		≤ 1 20		μA
Switch voltage Pin 14						
“Power ON”		V_{PON}	4			V
“Power DOWN”		V_{POFF}			1	V
LO input, LO_{in} Pin 17						
Frequency range		f_{iLO}	70		1000	MHz
Input level	Note 2	P_{iLO}	-12	-10	-5	dBm
Input impedance	See figure 6	Z_{iLO}		50		Ω
Voltage standing wave ratio	See figure 2	V_{SWRLO}		1.2	2	
Duty cycle range		LO_{DCR}	0.4		0.6	
RF input, RF_{in}						
Noise figure (DSB) symmetrical output	@ 950 MHz Note 3 @ 100 MHz Pins 7 and 8	NF		12 10		dB
Frequency range	Pins 7 and 8	f_{iRF}			$>f_{\text{iLO}}$	
-1 dB input compression point	High gain Pins 7 and 8 Low gain	ICPHG ICPLG		-8 +3.5		dBm
Second order IIP	Note 4 Pins 7 and 8	IIP2HG		35		dBm
Third order IIP	High gain Pins 7 and 8 Low gain	IIP3HG IIP3LG		+3 +13		dBm
LO leakage	Pins 7 and 8 Symmetric input Asymmetric input	LOL		≤ -60 ≤ -55		dBm
Input impedance	Pins 7 and 8 see figure 6	Z_{iRF}		$500\Omega \parallel$ 0.8pF		

Note 1: During power down status a load circuitry with dc-isolation to GND is assumed otherwise a current of $I \approx (V_S - 0.8\text{ V}) / R_I$ has to be added to the above power down current for each output I, IX, Q, QX.

Note 2: The required LO-Level is a function of the LO-frequency (see figure 3).

Note 3: Measured with input matching. For 950 MHz the optional transmission line T3 at the RF input may be used for this purpose. Noise figure measurements without using the differential output signal result in a worse noise figure.

Note 4: Using Pins 7 and 8 as a symmetric RF input, the second order IIP can be improved.

Electrical Characteristics

Test conditions (unless otherwise specified); $V_S = 5\text{ V}$, $T_{\text{amb}} = 25^\circ\text{C}$, referred to test circuit
System impedance $Z_O = 50\ \Omega$, $\text{fiLO} = 950\text{ MHz}$, $\text{PiLO} = -10\text{ dBm}$

Parameters	Test Conditions / Pins	Symbol	Min.	Typ.	Max.	Unit
I/O outputs	Emitter follower $I = 0.6\text{ mA}$	I, IX / Q, QX				
3 dB-bandwidth w/o external C	Note 5 Pins 1, 2, 19 and 20	BW/Q	≥ 30			MHz
I/Q amplitude imbalance	Pins 1, 2, 19 and 20	AII/Q		$\leq \pm 0.2$		dB
I/Q quadrature error	Pins 1, 2, 19 and 20	QEI/Q		$\leq \pm 1.5$		Deg
I/Q maximum output swing	Pins 1, 2, 19 and 20 Symm. output $R_L > 5\text{ k}\Omega$	Max I/Q			2	V _{PP}
DC output voltage	Pins 1, 2, 19 and 20	VOUT		2.8		V
DC output offset voltage	Note 6 Pins 1, 2, 19 and 20	VOFSI/Q I/IX Q/QX		< 5		mV
Output impedance	Pins 1, 2, 19 and 20 see figure 6	Zout		50		Ω
Gain control, GC						
Control range power gain, gain high/gain low	Note 7 Pin 11	GCR PGH/GGL		25 23/-2		dB
Switch voltage						
“Gain high”	Pin 11	GCVHigh			1	V
“Gain low”	Note 8 Pin 11	GCVLow				V
Settling time, ST						
Power “OFF” – “ON”		STON		< 4		μs
Power “ON” – “OFF”		STOFF		< 4		μs

Note 5: Due to test board parasitics this bandwidth is reduced and not equal for I, IX, Q, QX.

If symmetry and full bandwidth is required the lowpass Pins 3, 4 and 9, 10 should be isolated from the board.
The bandwidth of the I/Q outputs can be increased further by using a resistor between the Pins 3, 4, 9 and 10.
This resistors shunt the internal loads of $R_I \sim 5.4\text{ k}\Omega$ The decrease in gain here has to be considered.

Note 6: Output emitter follower internal acurrent $I = 0.6\text{ mA}$ allows only small voltage swing with a $50\ \Omega$ load.
For low signal distortion the load impedance should be $R_I \geq 5\text{ k}\Omega$

Note 7: Referred to the level of the output vector $\sqrt{I^2 + Q^2}$.

Note 8: The low gain status is achieved with an open or high ohmic Pin 11. A recommended application circuit for switching between high and low gain status is shown in figure 1.

Test Circuit

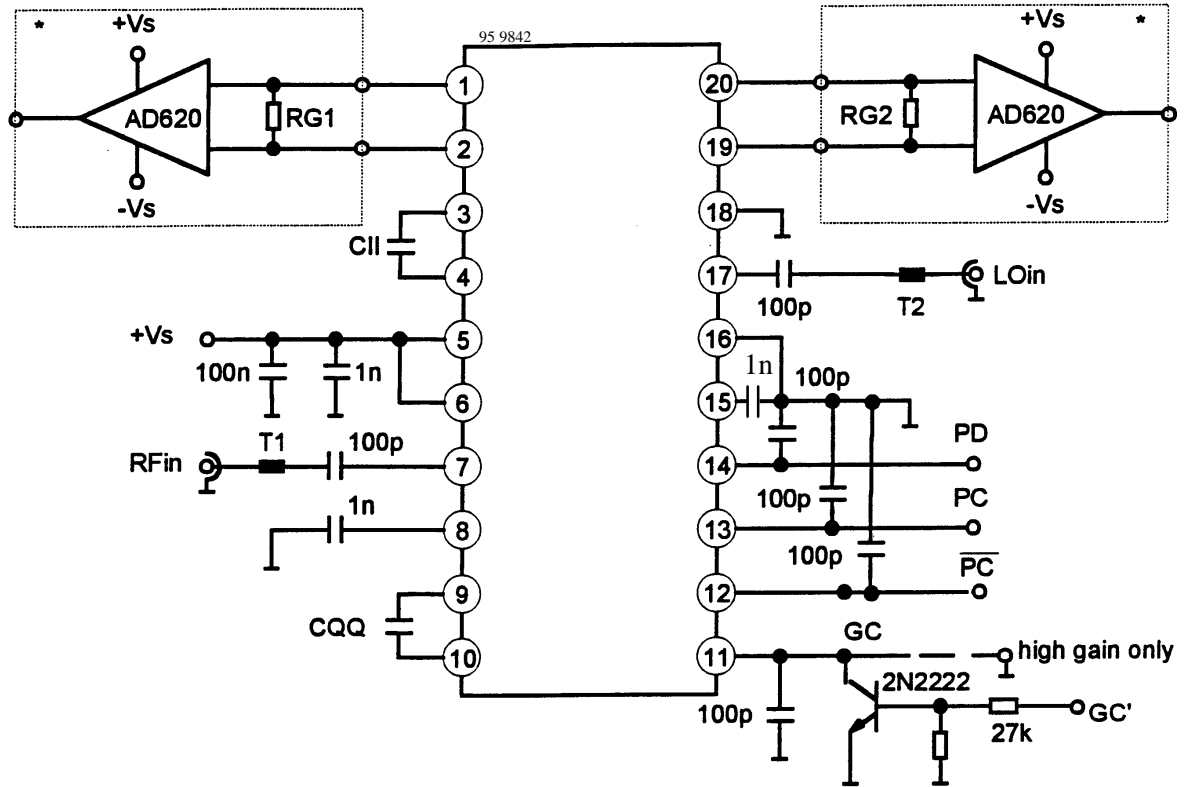

* optional for single ended tests (notice 3 dB bandwidth of AD620)
 T1, T2 = transmission line $Z_0 = 50 \Omega$.
 If no GC function is required, connect pin 11 to GND.
 For high and low gain status GC' is to be switched to GND respectively to V_S .

Figure 1.

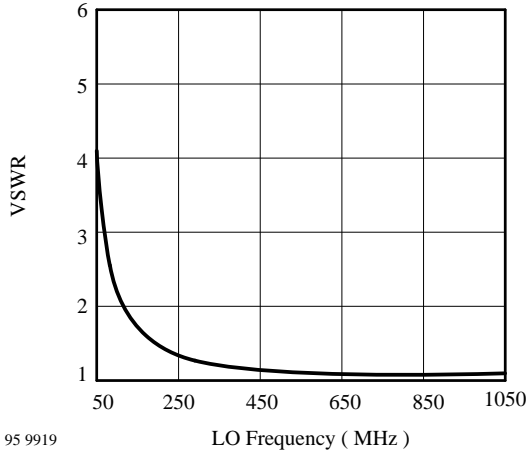

Figure 2. Typical VSWR frequency response of the LO input

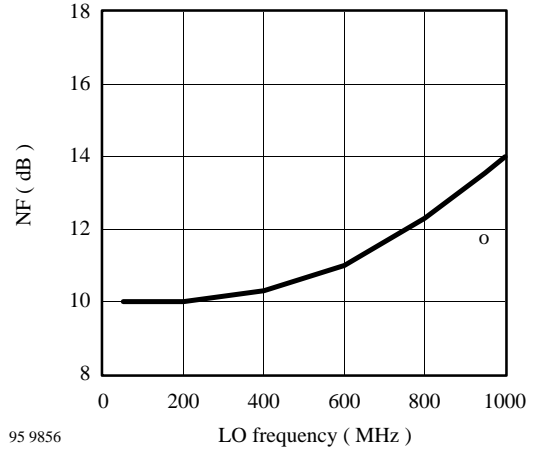

Figure 4. Noise figure vs. LO frequency;
o: value at 950 MHz with RF input matching with T3

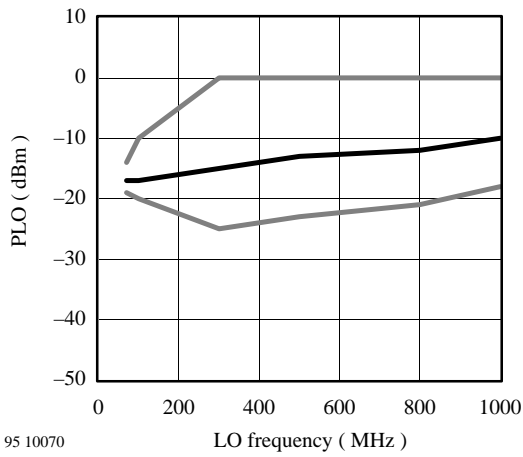

Figure 3. Typical suitable LO power range vs. frequency

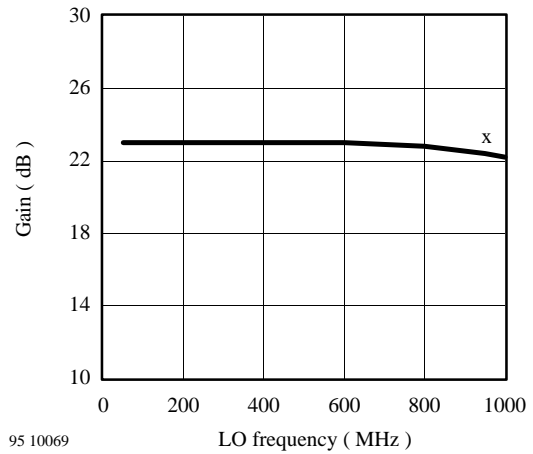

Figure 5. Gain vs. LO frequency;
x: value at 950 MHz with RF input matching with T3

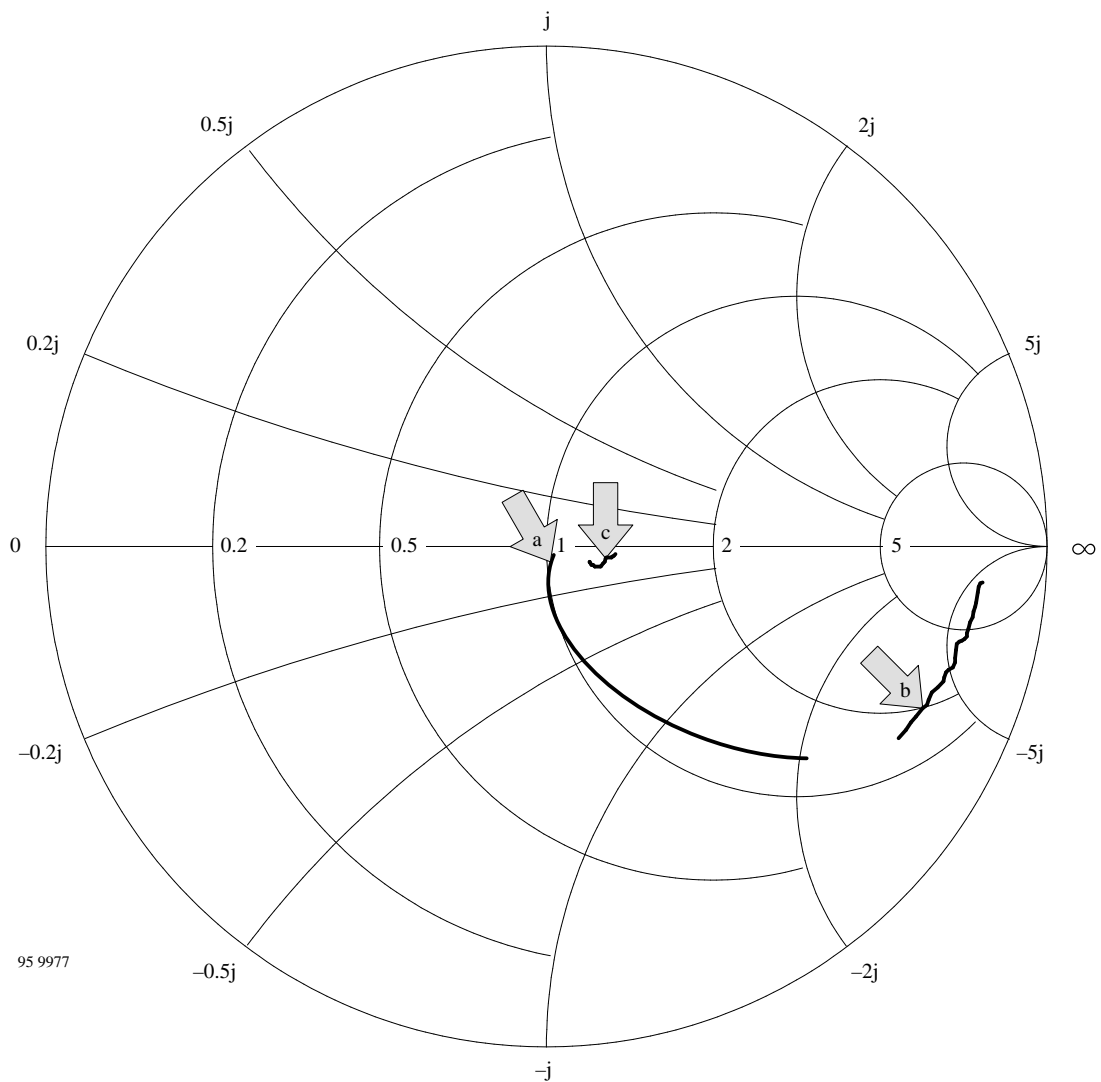

Figure 6. Typical S11 frequency response of the
 a: LO input, LO frequency from 100 MHz to 1100 MHz, marker: 950 MHz
 b: RF input, RF frequency from 100 MHz to 1100 MHz, marker: 950 MHz
 c: I/Q outputs, baseband frequency from 5 MHz to 55 MHz, marker: 25 MHz

U2794B

TEMIC

TELEFUNKEN Semiconductors

Board Layout

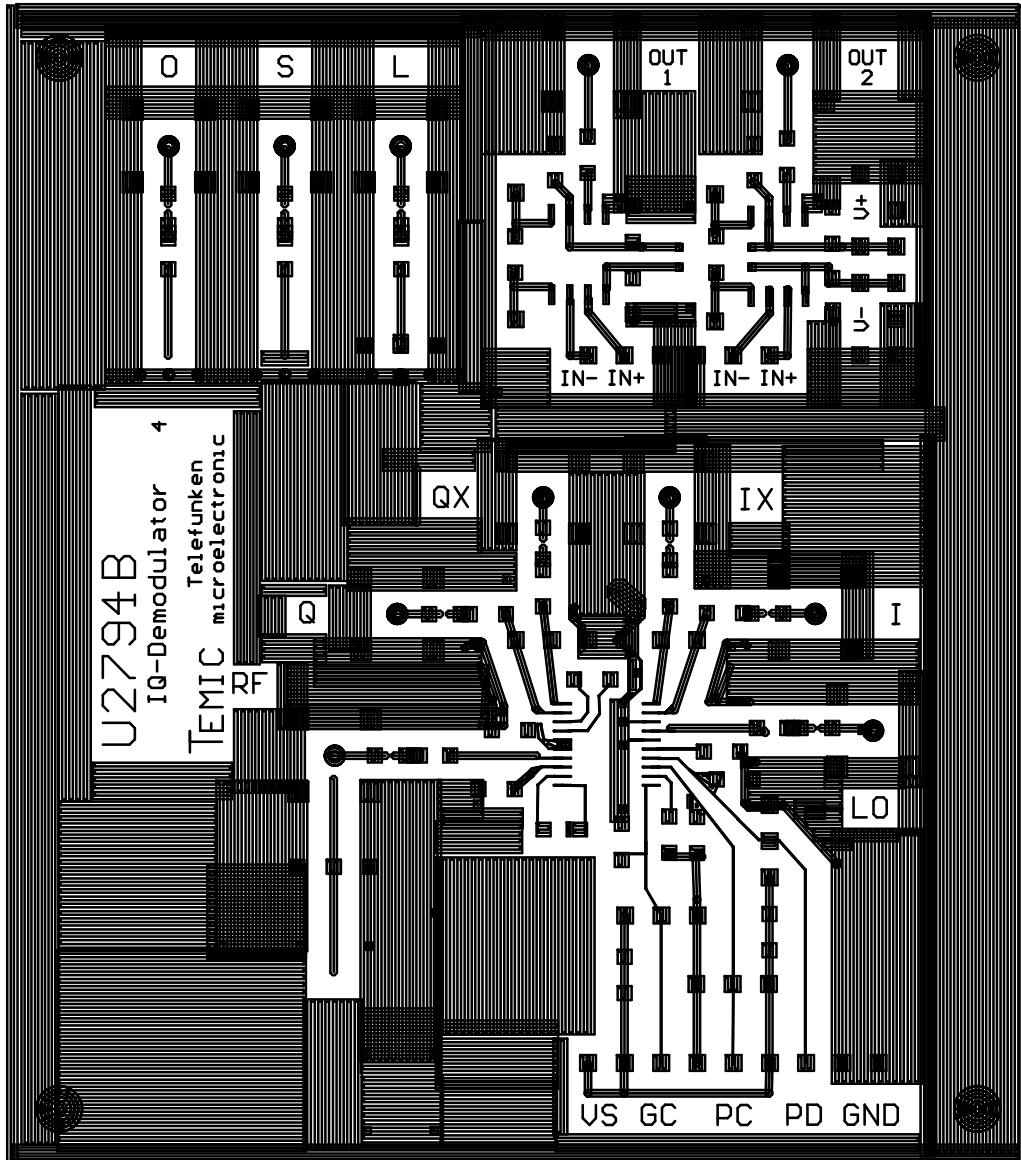

95 9854

Board Layout

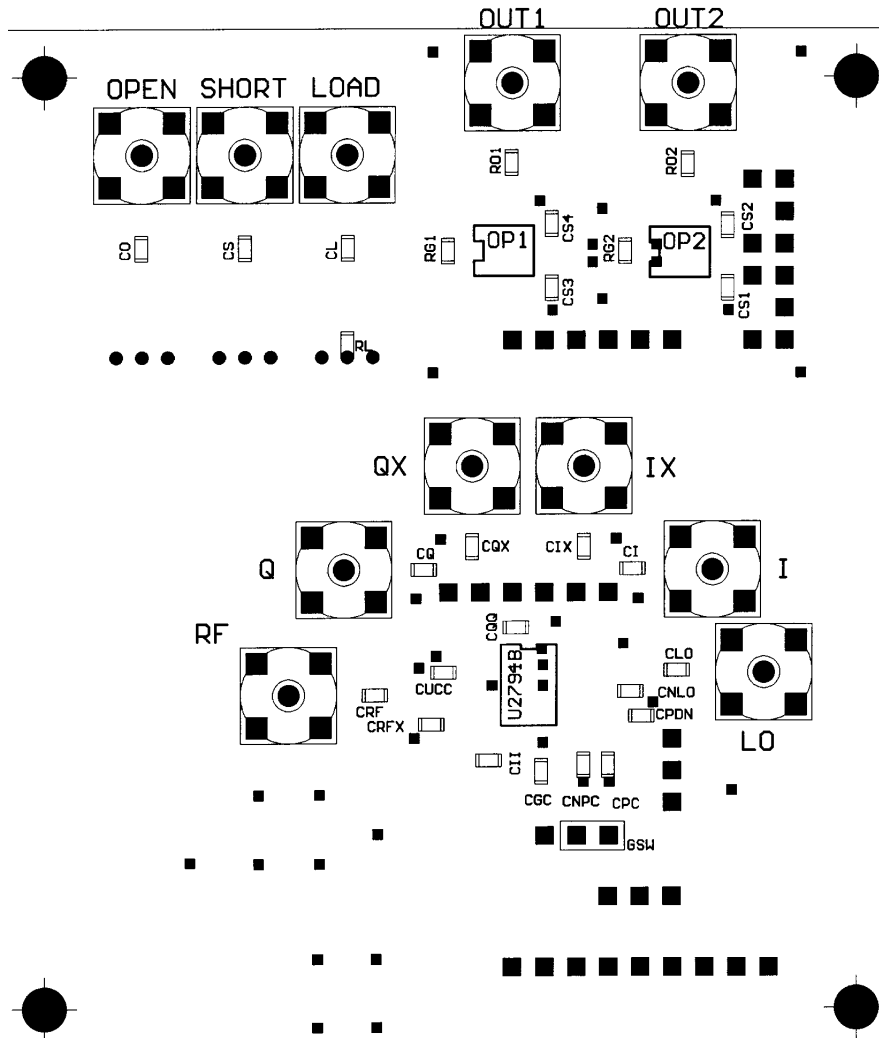

95 9853

External Components

CUCC 100 nF
 CRFX 1 nF
 CLO 100 pF
 CNLO 1 nF
 CRF 100 pF
 CII, CQQ optional external lowpass filters
 T3 transmission line for RF-input matching,
 to connect optionally
 CI, CIX, optional for ac-coupling at
 CQ, CQX baseband outputs
 CPDN 100 pF
 CGC 100 pF
 CPC 100 pF
 CNPC 100 pF
 GSW gain switch

Calibration Part

CO, CS, CL 100 pF
 RL 50 Ω

Conversion to Single Ended Output

OP1, OP2 AD620
 RG1, RG2 prog. gain, see datasheet, for 5.6 k Ω a
 gain of 1 at 50 Ω is achieved together
 with RD1 and RD2.
 RD1, RD2 450 Ω
 CS1, CS2 100 nF
 CS3, CS4, 100 nF

U2794B

Description of Evaluation Board

Board material: epoxy; $\epsilon_r = 4.8$, thickness = 0.5 mm
 transmission lines: $Z_0 = 50 \Omega$

The board offers the following functions

- The test circuit for the U2794B:
 - The supply voltage and the control inputs GC, PC and PD are connected via a plug strip. The control input voltages can be generated via external potentiometers; then the inputs should be ac-grounded (time requirements in burst-mode for power up have to be considered).
 - The outputs I, IX, Q, QX are dc coupled via an plug strip or can be ac-connected via SMB plugs for high frequency tests e.g. noise figure or s-parameter measurement. The pins II, IIX, QQ, QXX allow user definable filtering with 2 external capacitors CII, CQQ.
 - Also the offsets of both channels can be adjusted with two pots or resistors.
- The LO- and the RF-inputs are ac-coupled and connected via SMB plugs. If transmission line T3 is connected to the RF-input and ac-grounded at the other end, gain and noise performance can be improved (input matching to 50Ω).
- The complementary RF-input is ac-coupled to GND (CRFX = 1 nF), the same appears to the complementary LO-input (CNLO = 1 nF).
- A calibration part, which allows to calibrate an s-parameter analyzer directly to the in- and output-signal ports of the U2794B.
- For single-ended measurements at the demodulator outputs, two OP's (e.g., AD620 or other) can be configured with programmable gain; together with an output-divider network $RD = 450 \Omega$ to $RL = 50 \Omega$, direct measurements with 50Ω load-impedances are possible at frequencies < 100 kHz.

Dimensions in mm

Package: SSO 20

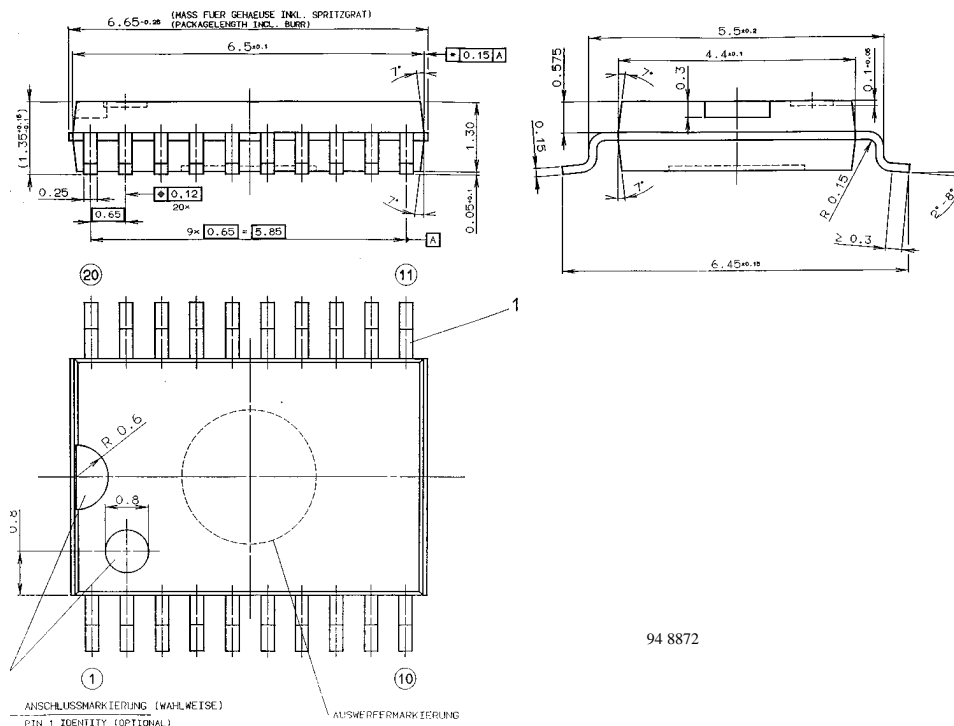

94 8872

Ozone Depleting Substances Policy Statement

It is the policy of **TEMIC TELEFUNKEN microelectronic GmbH** to

1. Meet all present and future national and international statutory requirements.
2. Regularly and continuously improve the performance of our products, processes, distribution and operating systems with respect to their impact on the health and safety of our employees and the public, as well as their impact on the environment.

It is particular concern to control or eliminate releases of those substances into the atmosphere which are known as ozone depleting substances (ODSs).

The Montreal Protocol (1987) and its London Amendments (1990) intend to severely restrict the use of ODSs and forbid their use within the next ten years. Various national and international initiatives are pressing for an earlier ban on these substances.

TEMIC TELEFUNKEN microelectronic GmbH semiconductor division has been able to use its policy of continuous improvements to eliminate the use of ODSs listed in the following documents.

1. Annex A, B and list of transitional substances of the Montreal Protocol and the London Amendments respectively
2. Class I and II ozone depleting substances in the Clean Air Act Amendments of 1990 by the Environmental Protection Agency (EPA) in the USA
3. Council Decision 88/540/EEC and 91/690/EEC Annex A, B and C (transitional substances) respectively.

TEMIC can certify that our semiconductors are not manufactured with ozone depleting substances and do not contain such substances.

We reserve the right to make changes to improve technical design and may do so without further notice.

Parameters can vary in different applications. All operating parameters must be validated for each customer application by the customer. Should the buyer use TEMIC products for any unintended or unauthorized application, the buyer shall indemnify TEMIC against all claims, costs, damages, and expenses, arising out of, directly or indirectly, any claim of personal damage, injury or death associated with such unintended or unauthorized use.

TEMIC TELEFUNKEN microelectronic GmbH, P.O.B. 3535, D-74025 Heilbronn, Germany
Telephone: 49 (0)7131 67 2831, Fax number: 49 (0)7131 67 2423