

FM Receiver

Description

The IC U4065B is a bipolar integrated FM-frontend circuit. It contains a mixer, an oscillator, two IF preamplifiers and an unique interference sensor. The

device is designed for high performance car radio and home receiver applications.

Features

- All frontend functions of a high performance FM-receiver, except the RF preamplifier, are integrated
- Improved dynamic range by high current double balanced mixer design and a new AGC conception with 3 loops on chip
- Improved blocking and intermod behavior by use of an unique "interference" sensor controlling the AGC
- Easy cascading of three IF filters (ceramic) by use of two on-chip IF preamplifiers
- On-chip control functions are available for system gain adjust (dB linear vs. dc current)
- Low noise LO design
- ESD protected

Block Diagram

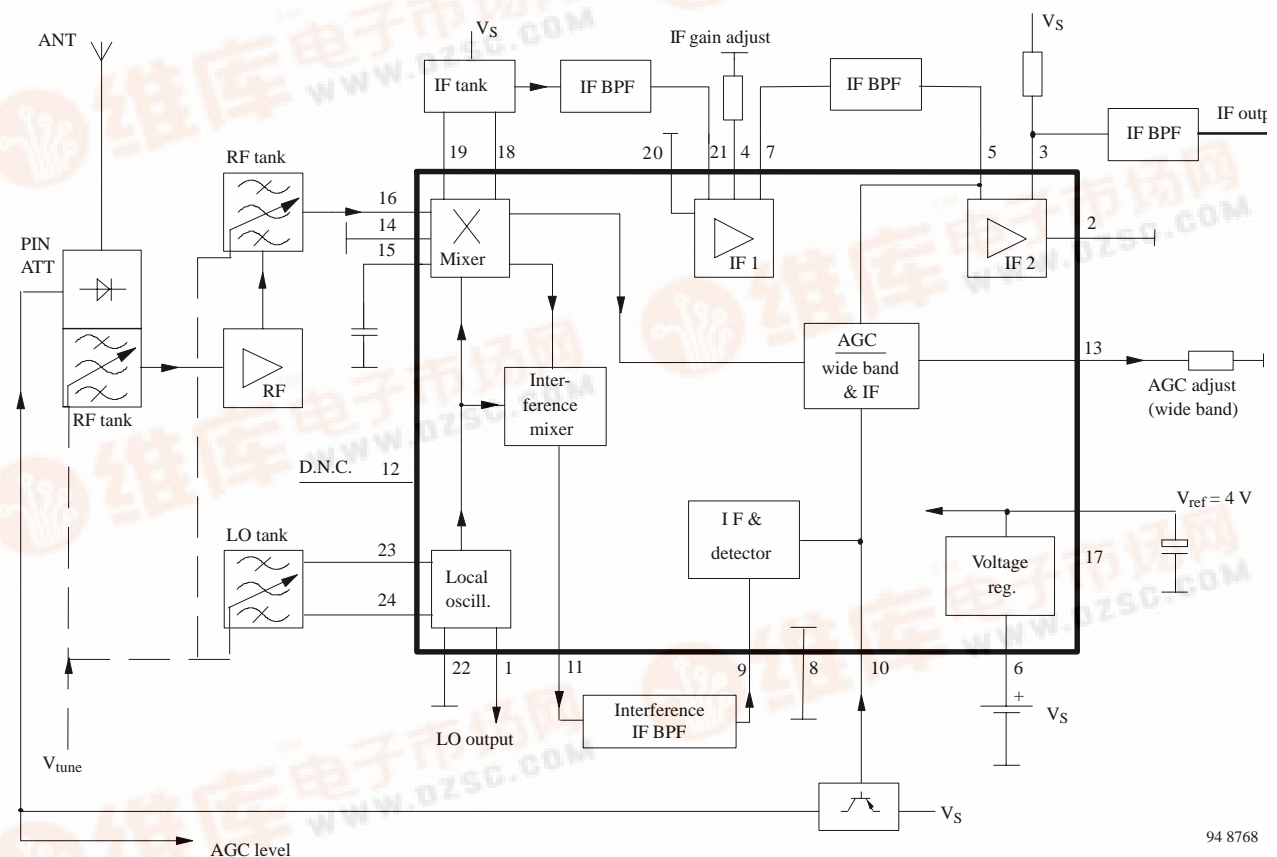

94 8768

Pin Description

Pin	Symbol	Function
1	LOBUFF	Buffered local oscillator output
2	GND1	Ground of the second IF amplifier
3	IF2OUT	Output of the second IF amplifier
4	GAINIF1	Gain control of the first IF amplifier
5	IF2IN	Input of the second IF amplifier
6	VS	Supply voltage
7	IF1OUT	Output of the first IF amplifier
8	GND2	Ground
9	IMIFIN	Input of the amplifier for the IM-sensor
10	AGCOUT	Output of the automatic gain control
11	IMMIXOUT	Output of the intermodulation mixer
12	D.N.C.	Do not connect

Pin	Symbol	Function
13	AGCWB	Threshold adjustment of the wideband AGC
14	GND3	Mixer ground
15	MIXIN1	Input 1 of the double balanced mixer
16	MIXIN2	Input 2 of the double balanced mixer
17	VREF	Reference voltage output
18	MIXOUT1	Mixer output 1
19	MIXOUT2	Mixer output 2
20	GND4	Ground of the first IF amplifier
21	IF1IN	Input of the first amplifier
22	GND5	Oscillator ground
23	LOE	Local oscillator (emitter)
24	LOB	Local oscillator (base)

LOBUFF

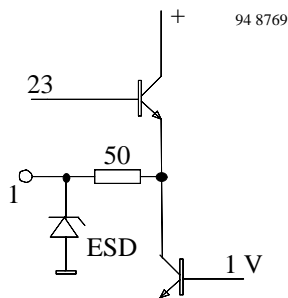

Buffered local oscillator output:

It drives the FM-input of the PLL circuit (for example U428xBM-family). The typical parallel output resistance at 100 MHz is 70 Ω , the parallel output capacitance is about 10 pF. When using an external load of 500 Ω / 10 pF, the oscillator swing is about 100 mV. The second harmonic of the oscillator frequency is less than -15 dBc.

GND1

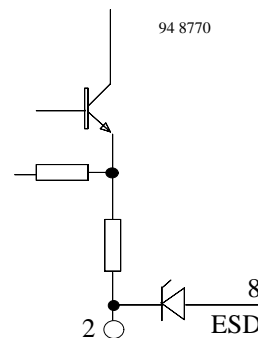

Ground of the second IF amplifier:

There is no internal connection to the other ground pins.

IF2OUT

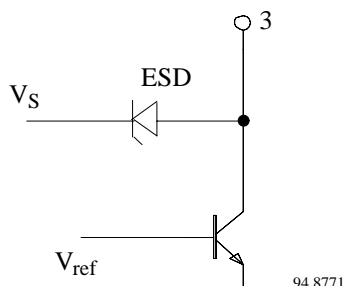

Output of the second IF amplifier:

The parallel output capacitance to ground is about 7 pF. The external load resistance is to connect to V_S . The dc current into the pin is typically 3 mA.

Note: Supply voltage V_S has to be protected against IF-distortion

GAINIF1

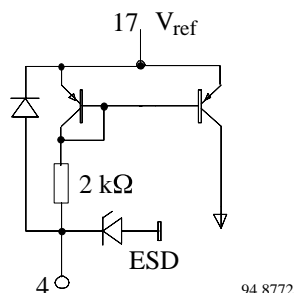

Gain control of the first IF amplifier:

The gain of the first IF amplifier can be adjusted by a resistor to ground. This is useful for example to compensate the insertion loss tolerances of the ceramic BPF's. Please ensure that the output current of the pin does not exceed 150 μ A in any case. Linear increasing in the current out of GAINIF1 effects dB linear increasing of the gain (0.15 dB/ μ A).

$$I_4 = 0 \Rightarrow G = G_{min} = 2 \text{ dB}$$

$$I_4 = 140 \mu\text{A} \Rightarrow G = G_{max} = 22 \text{ dB}$$

IF2IN

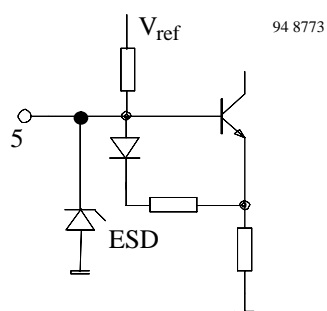

Input of the second IF amplifier:

The parallel input resistance is 330 Ω . The parallel input capacitance is about 12 pF. No dc current is allowed. To avoid overload of this stage an internal detector watches the input level and causes current at the AGCOUT pin.

IF1OUT

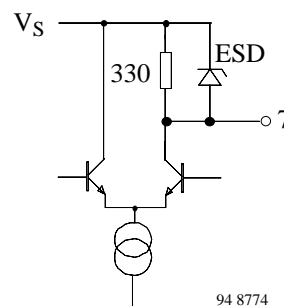

Output of the first IF amplifier:

The parallel output resistance is 330 Ω which allows the use of a standard ceramic BPF. The parallel output capacitance is about 7 pF. The dc voltage at the pin is 0.5 V less than V_S .

IMIFIN

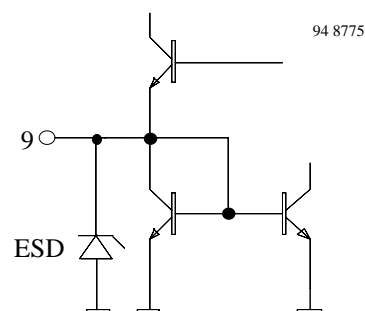

Input of the IF amplifier for the IM-sensor:

The parallel input resistance is 330 Ω . The amplifier is extremely sensitive to ac signals. A few hundred μ V of IF-signal at this pin will cause current at the AGC output. Therefore pay attention when connecting the standard ceramic filter used between IMOUT and this pin. The reference point of the filter has to be free of any ac signal. Please avoid dc current at this pin.

AGCOUT

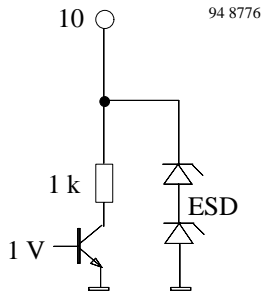

Output of the automatic gain control:

The AGC output is an open collector output. The current of the pin diode is this current multiplied by the current gain of the external PNP transistor. The dc voltage at the pin may vary from 2 V to V_S , therefore you can easily use this pin as an indicator of the AGC regulation state.

IMMIXOUT

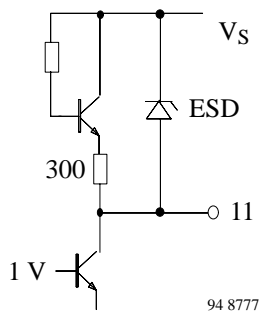

Output of the intermodulation mixer:

The parallel output resistance is 330 Ω which allows the use of a standard ceramic BPF without any further matching network. Please ensure that the ground-pin of the filter is free of ac signals.

AGCWB

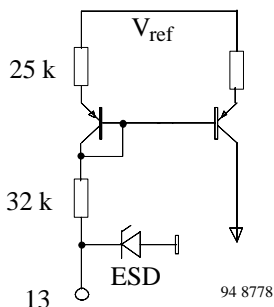

Threshold adjustment of the wideband AGC:

The threshold of the wideband AGC can be adjusted by an external resistor to ground. The setting range is 10 dB. For minimum blocking this pin is connected to ground. In order to set the threshold to smaller levels the resistance value should be up to a few hundred kΩ.

MIXIN1

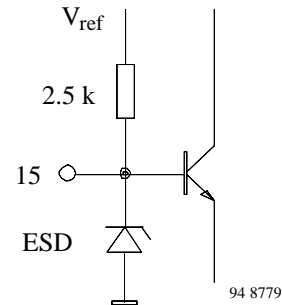

Input 1 of the double balanced mixer:

The parallel input resistance is 1.2 kΩ. The parallel input capacitance is about 9 pF. When using the mixer unbalanced this pin is to be grounded for RF-signals by an external capacitance of a few nF. DC current is not allowed.

MIXIN2

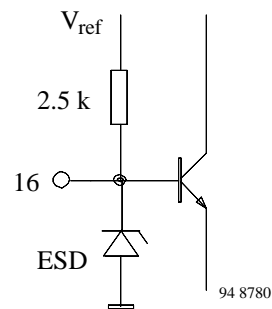

Input 2 of the double balanced mixer:

The parallel input resistance is 1.6 kΩ. The parallel input capacitance is about 7 pF. The double sideband noise figure of the unbalanced mixer is about 7 dB. In the balanced case the noise figure will be reduced by about 0.8 dB.

VREF

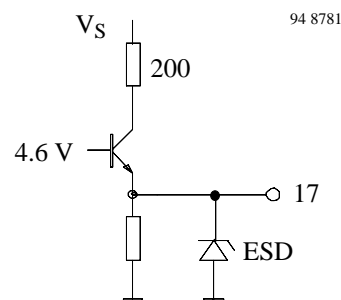

Reference voltage:

The internal temperature compensated reference voltage is 3.9 V. It is used as bias voltage for most blocks, so the electrical characteristics of the U4065B are widely independent of the supply voltage. The internal output resistance of the reference voltage is less than 10 Ω. To avoid internal coupling across this pin external capacitors are required. The maximum output current is $I_{ref} = 5$ mA.

MIXOUT1, MIXOUT2

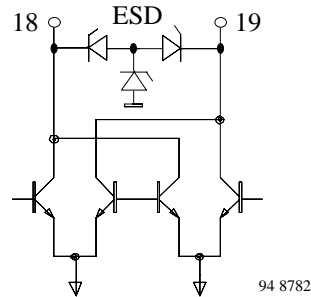

Mixer output 1, 2:

The mixer output is an open collector of a bipolar transistor. The minimum voltage at this pins is 5 V (V_S -voltage swing). The dc current into this pins is typically 9 mA. Good LO- and RF suppression at the mixer output can be achieved by symmetrical load conditions at the pins MIXOUT1 and MIXOUT2.

IF1IN

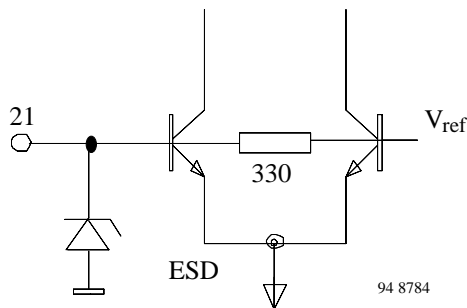

Input of the first IF amplifier:

The typical input resistance is 330 Ω . The dc voltage is nearly the same one as the reference voltage. Please avoid dc current at this pin.

LOE

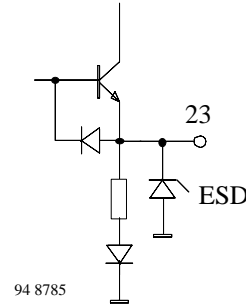

Emitter of the local oscillator:

An external capacitor is connected between LOE and ground. The ground pin of this capacitor is to connect to the pin GND5. GND5 is the chip internal ground of the local oscillator.

LOB

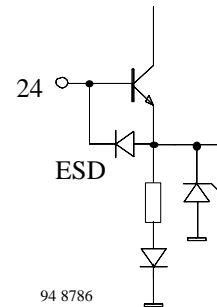

Base of the local oscillator:

The tank of the local oscillator is connected at pin LOB. The ground pin of this tank is to connect to the pin GND5. GND5 is the chip internal ground into pin 24 of the local oscillator. The resonant resistance of the tank should be about 250 Ω . Minimum Q of the unloaded tank is 50.

Functional Description

The U4065B FM-frontend IC is the dedicated solution for high end car radios. A new design philosophy enables to build up tuners with superior behavior. This philosophy is based on the fact that the sensitivity of state of the art designs is at the physical border and cannot be enhanced any more. On the other hand, the spectral power density in the FM-band increases. An improvement of reception can only be achieved by increasing the dynamic range of the receiver. This description is to give the designer an introduction to get familiar with this new product and its philosophy.

1. The Signal Path

The U4065B offers the complete signal path of an FM-frontend including a highly linear mixer and two IF preamplifiers. The mixer is a double balanced high current Gilbert Cell. A high transit frequency of the internal transistors enables the use of the emitter grounded circuit with its favorable noise behavior. The full balanced output offers LO carrier reduction.

The following IF preamplifier has a dB-linear gain adjustment by dc means. Thus different ceramic filter losses can be compensated and the overall tuner gain can be adapted to the individual requirements. The low noise design suppresses post stage noise in the signal path. Input- and output resistance is $330\ \Omega$ to support standard ceramic filters. This was achieved without feedback, which would cause different input impedances when varying the output impedance.

The second IF preamplifier enables the use of three ceramic filters with real $330\ \Omega$ input- and output termination. Feedthrough of signals is kept low. The high level of output compression is necessary to keep up a high dynamic range.

Beneath the signal path the local oscillator part and the AGC signal generation can be found on chip. The local oscillator uses the collector grounded colpitts type. A low phase noise is achieved with this access. A mutual coupling in the oscillator coil is not necessary.

2. The AGC Concept

Special care was taken to design a unique AGC concept. It offers 3 AGC loops for different kinds of reception conditions. The most important loop is the interference sensor part.

In today's high end car radios, the FM AGC is state of the art. It is necessary to reduce the influence of 3rd and higher order intermodulation to sustain reception in the presence of strong signals in the band. On one hand, it makes a sense to reduce the desired signal level by AGC as few as possible to keep up stereo reception, on the other

hand two or more strong out of channel signals may interfere and generate an intermodulation signal on the desired frequency. By introducing input attenuation, the level of the intermod signal decreases by a higher order, whereas the level of the desired signal shows only a linear dependency on the input attenuation. Therefore input attenuation by pin diodes may keep up reception in the presence of strong signals.

The standard solution to generate the pin diode current is to pick up the RF-signal in front of the mixer. Because the bandwidth at that point is about 1.5 MHz, this is called wideband AGC. The threshold of AGC start is a critical parameter. A low threshold does not allow any intermodulation but has the disadvantage of blocking if there is only one strong station on the band or if the intermod signals do not cover the desired channel. A higher AGC threshold may tolerate a certain ground floor of intermodulation. This avoids blocking, but it has the disadvantage, that no reception is possible, if the interfering signals do generate an intermod signal inside the desired channel. This contradiction could not be overcome in the past.

With the new U4065B IC, a unique access to this problem appears. This product has an interference sensor on chip. Thus an input signal attenuation is only performed, if the interfering signals do generate an intermod signal inside the desired channel. If they do not, the still existing wideband AGC is yet active but at up to 20 dB higher levels. The optimum AGC state is always generated.

The figures 1 to 4 illustrate the situation. In figure 1 the AGC threshold of a standard tuner is high to avoid blocking. But then the intermod signal suppresses the desired signal. The interference sensor of the U4065B takes care that in this case the AGC threshold is kept low as illustrated in figure 2.

In figure 3 the situation is vice versa. The AGC threshold of a standard tuner is kept low to avoid intermod problems. But then blocking makes the desired signal level drop below the necessary stereo level. In this case, the higher wideband AGC level of the U4065B enables perfect stereo reception.

By principle, this interference sensor is an element with a third order characteristic. For input levels of zero, the output level is zero, too. With increasing input level, the output level is increased with the power of three, thus preferring intermod signals compared to linear signals. At the same time, a down conversion to the IF level of 10.7 MHz is performed. If a corresponding 10.7 MHz IF filter selects the intermod signals, an output is only generated, if an intermod signal inside the 10.7 MHz channel is present.

The circuit blocks interference sensor and IF & detector build up a second IF chain. In an FM system, the max deviation of a 3rd order intermod signal is the triple max deviation of the desired signal. Therefore the ceramic IF BPF between Pin 11 and Pin 9 may be a large bandwidth type. This external part is the only additional amount for

this unique feature.

A further narrow band AGC avoids overriding the second IF amplifier. The amplitude information of the channel is not compressed in order to maintain multipath detection in the IF part of the receiver.

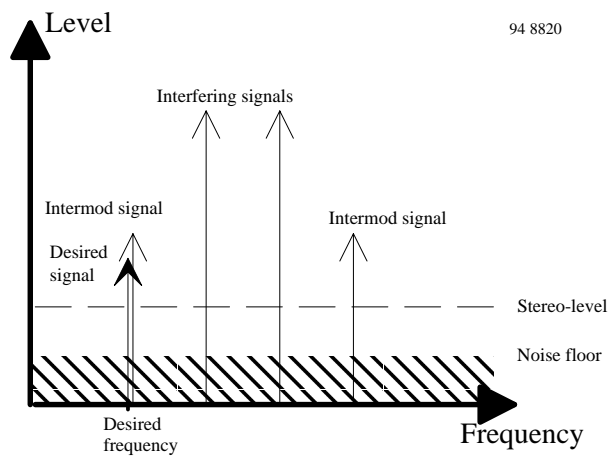

Figure 1 A high AGC threshold causes the intermod signal to suppress the desired signal

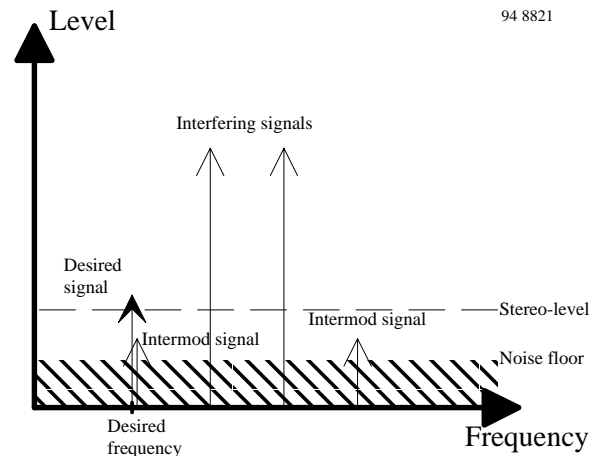

Figure 2 The correct AGC threshold of the U4065B provides optimum reception

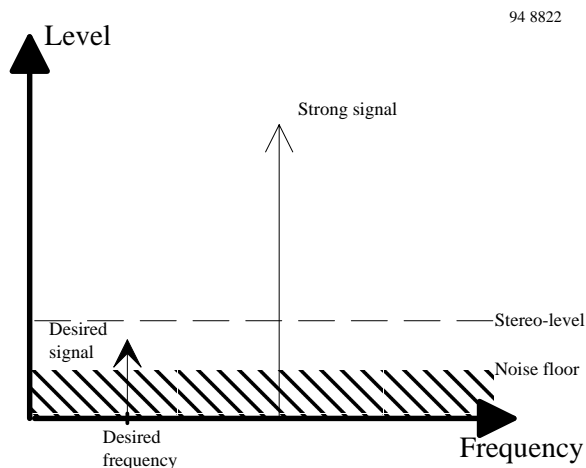

Figure 3 A low AGC threshold causes the blocking signal to suppress the desired signal

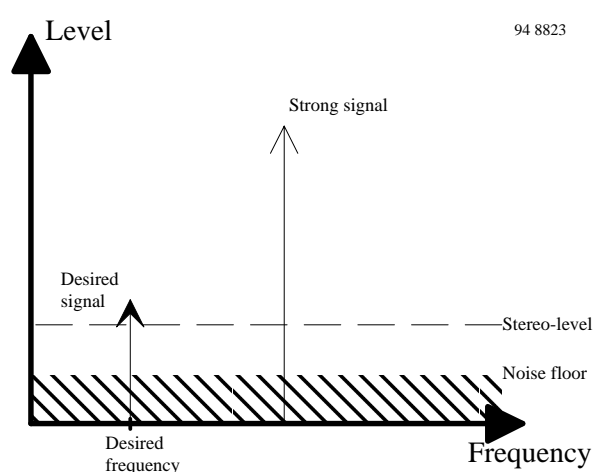

Figure 4 The correct AGC threshold of the U4065B provides optimum reception

Absolute Maximum Ratings

Reference point is ground (Pins 2, 8, 14, 20 and 22)

Parameters	Symbol	Value	Unit
Supply voltage	V_S	10	V
Power dissipation at $T_{amb} = 85^\circ\text{C}$	P_{tot}	470	mW
Junction temperature	T_j	125	$^\circ\text{C}$
Ambient temperature range	T_{amb}	- 30 to + 85	$^\circ\text{C}$
Storage temperature range	T_{stg}	- 50 to + 125	$^\circ\text{C}$
Electrostatic handling: Human body model (HBM), all I/O pins tested against the supply pins.	$\pm V_{ESD}$	2000	V

Thermal Resistance

Parameters	Symbol	Maximum	Unit
Thermal resistance	R_{thJA}	90	K/W

Electrical Characteristics

$V_S = 8.0\text{ V}$, $f_{RF} = 98\text{ MHz}$, $f_{OSC} \cong 108.7\text{ MHz}$, $f_{IF} = f_{OSC} - f_{RF} = 10.7\text{ MHz}$

Reference point ground (Pins 2, 8, 14, 20 and 22), $T_{amb} = 25^\circ\text{C}$, unless otherwise specified

Parameters	Test Conditions / Pins	Symbol	Min.	Typ.	Max.	Unit
Supply voltage	Pins 3, 6, 10, 18 and 19	V_S	7	8	10	V
Supply current	Pins 3+6+10+18+19	I_{tot}		37	47	mA
Oscillator (GND5 has to be connected to external oscillator components)						
Oscillator voltage	$R_{g24} = 220\ \Omega$, unloaded Q of $L_{OSC} = 70$, $R_{L1} = 520\ \Omega$ Pin 24 Pin 23 Pin 1	V_{LOB} V_{LOE} V_{LOBUFF}	70	160 100 90	220	mV
Harmonics	Pin 1				-15	dBc
Output resistance	Pin 1	R_{LO}		70		Ω
Voltage gain	Between pins 1 and 23			0.9		
Mixer (GND3 has to be separated from GND1, GND2 and GND4)						
Conversion power gain	Source impedance:	G_C	5	7	10	dB
3rd order input intercept	$R_{G15,16} = 200\ \Omega$	IP_3	4	6	14	dBm
Conversion transconductance	Load impedance: $R_{L18,19} = 200\ \Omega$	g_C		8		mA/V
Noise figure		NF_{DSB}		7		dB
Input resistance to ground	Pin 15	R_{ignd15}		1.2		k Ω
Input capacitance to ground	$f = 100\text{ MHz}$	C_{ignd15}		9		pF
Input resistance to ground	Pin 16	R_{ignd16}		1.6		k Ω
Input capacitance to ground	$f = 100\text{ MHz}$	C_{ignd16}		7		pF
Input-input resistance	Between Pin 15 and Pin 16	$R_{ii15,16}$		1.6		k Ω
Input-input capacitance	Between Pin 15 and Pin 16	$C_{ii15,16}$		5		pF
Output capacitance to GND	Pin 18 and Pin 19	$C_{ignd18,19}$		9		pF
First IF preamplifier (IF 1)						
Gain control deviation by I_4	Pin 4		17	20	24	dB
Gain control slope		dG_{IF1}/dI_4		0.15		dB/ μA

Electrical Characteristics (continued)

$V_S = 8.0\text{ V}$, $f_{RF} = 98\text{ MHz}$, $f_{OSC} \cong 108.7\text{ MHz}$, $f_{IF} = f_{OSC} - f_{RF} = 10.7\text{ MHz}$

Reference point ground (Pins 2, 8, 14, 20 and 22), $T_{amb} = 25^\circ\text{C}$, unless otherwise specified

Parameters	Test Conditions / Pins	Symbol	Min.	Typ.	Max.	Unit
External control current to ground at G_{min} at G_{nom} at G_{max}		I_{4min} I_{4nom} I_{4max}		0 70 140		μA
Power gain at I_{4min} at I_{4nom} at I_{4max}	Between pins 21 and 7 Source impedance:	G_{min} G_{nom} G_{max}	-2.5 11 19	2 12 22	2.5 16 28	dB
Noise figure at G_{max} at G_{nom} at G_{min}	$R_{G21} = 200\ \Omega$, Load impedance: $R_{L7} = 200\ \Omega$	NF_{min} NF_{nom} NF_{max}		7 9 15		dB
Temperature coefficient of the gain at G_{nom}		TKnom		+0.045		dB/K
1 dB compression at G_{nom}	Pin 7	V_{cnom}		70		mV
-3 dB cutoff freq. at G_{nom}	Pin 7	f_{cnom}		50		MHz
Input resistance	Pin 21	R_{iIF1}	270	330	400	Ω
Input capacitance	$f = 10\text{ MHz}$	C_{iIF1}		5		pF
Output resistance	Pin 7	R_{oIF1}	270	330	400	Ω
Output capacitance	$f = 10\text{ MHz}$	C_{oIF1}		7		pF
Second IF preamplifier (IF 2)						
Power gain	Between pins 5 and 3 Source impedance: $R_{G5} = 200\ \Omega$ Load impedance: $R_{L3} = 200\ \Omega$	G_{IF2}	15	18	19	dB
Noise figure		NF_{IF2}		7		dB
1 dB compression	Pin 3	V_{comp}		500		mV
-3 dB cutoff frequency	Pin 3	f_c		50		MHz
Parallel input resistance	Pin 5	R_{iIF2}	270	330	400	Ω
Parallel input capacitance	$f = 10\text{ MHz}$	C_{iIF2}		12		pF
Parallel output resistance	Pin 3	R_{oIF2}		50		k Ω
Parallel output capacitance	$f = 10\text{ MHz}$	C_{oIF2}		7		pF
Voltage regulator						
Regulated voltage	Pin 17	V_{ref}	3.7	3.9	4.9	V
Maximum output current	Pin 17	I_{ref}	5			mA
Internal differential resistance, dc_{17}/di_{17} when $I_{17} = 0$	Pin 17	r_{d17}		7	50	Ω
Power supply suppression	$f = 50\text{ Hz}$, Pin 17	psrr	36	50		dB
AGC input voltage thresholds (AGC threshold current is $10\ \mu\text{A}$ at Pin 10)						
IF2 input	Pin 5	V_{thIF2}	85	86	92	dB μV
IF & detector	Pin 9	V_{thIFD}	42	43	48	dB μV
Mixer input level of wideband sensor	Between Pins 15 and 16 $f_{iRF} = 100\text{ MHz}$ V at pin 13 = 0 V I through pin 13 = 0 A	V_{thWB1} V_{thWB2}	95 85	98 87	100 90	dB μV dB μV

Test Circuit

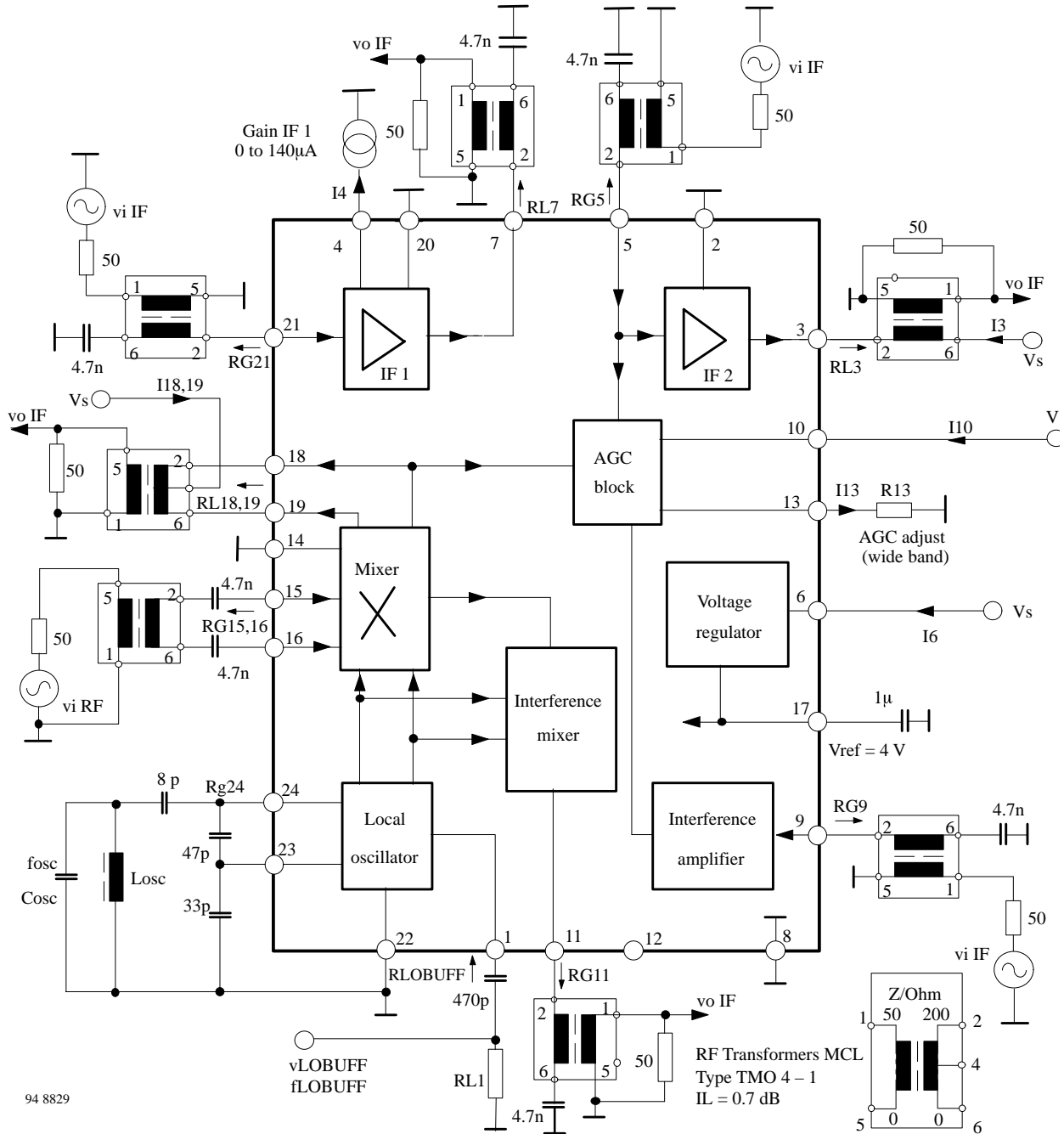

Local Oscillator

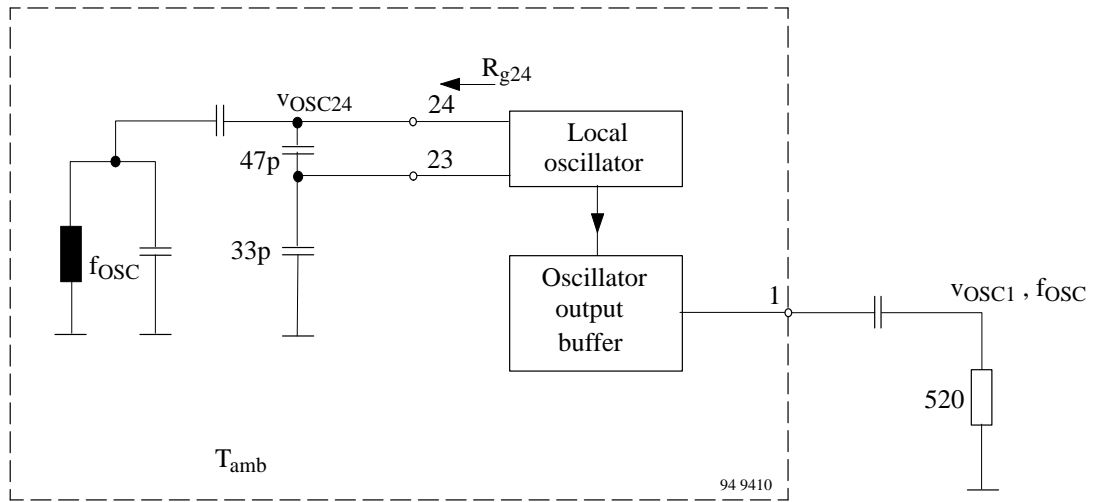

Free running oscillator frequency $f_{OSC} \approx 110$ MHz, $v_{OSC24} = 160$ mV, $R_{g24} = 220 \Omega$, $Q_L = 70$

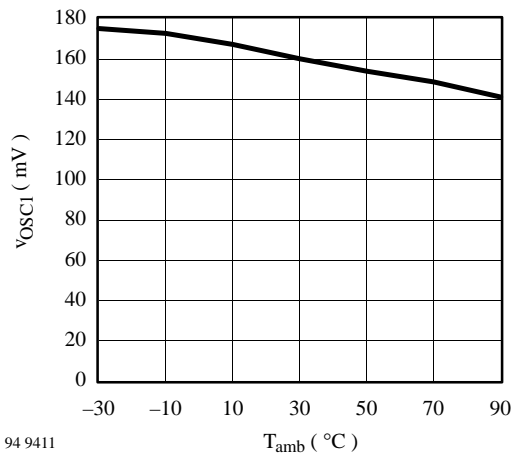

Oscillator swing versus temperature

Mixer

$f_{OSC} = 110.7 \text{ MHz}$, $v_{OSC24} \cong 160 \text{ mV}$, $f_{IF} = 10.7 \text{ MHz}$

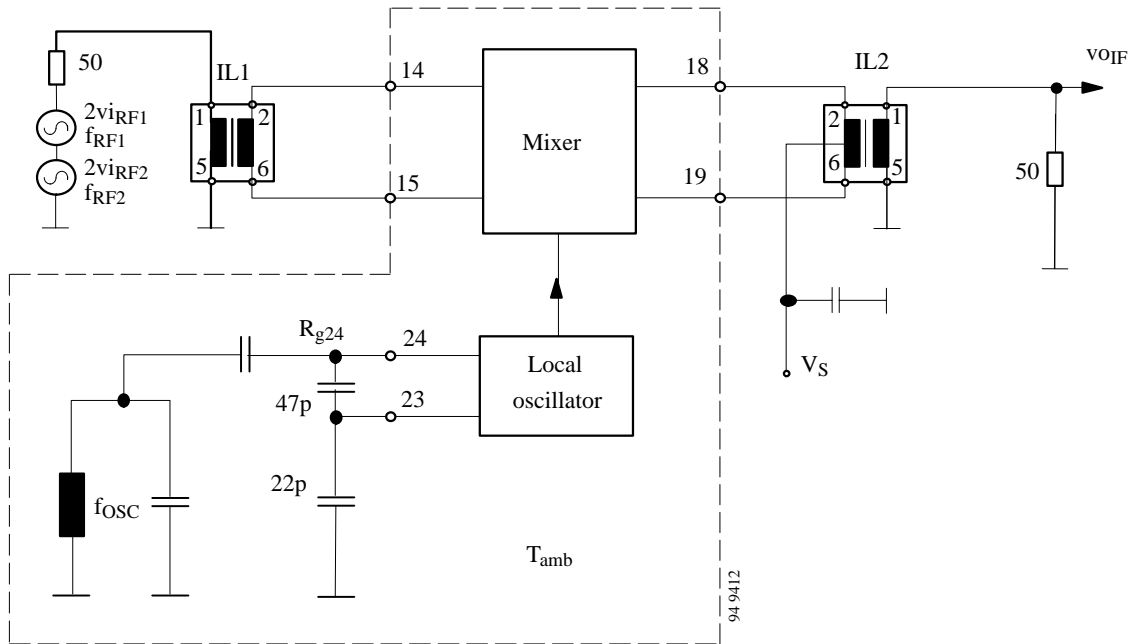

Conversion power gain $G_C = 20 \log (v_{OIF}/v_{iRF}) + IL1 \text{ (dB)} + IL2 \text{ (dB)}$
 IL1, IL2 insertion loss of the RF transformers

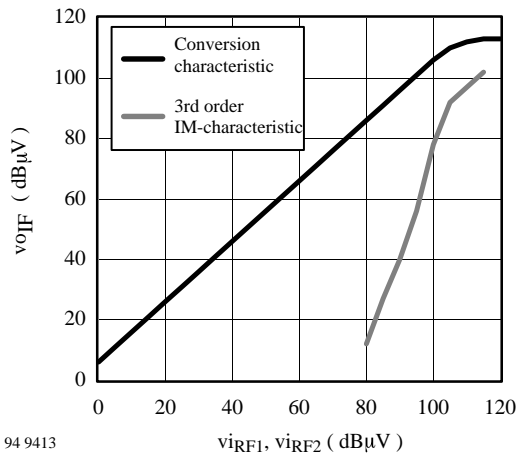

Characteristic of the mixer

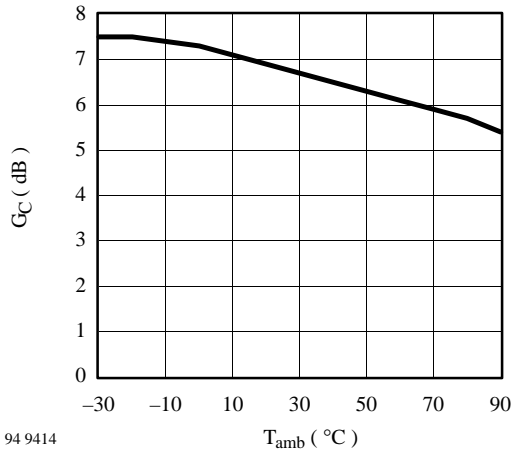

94 9414

Conversion power gain of the mixer stage versus temperature

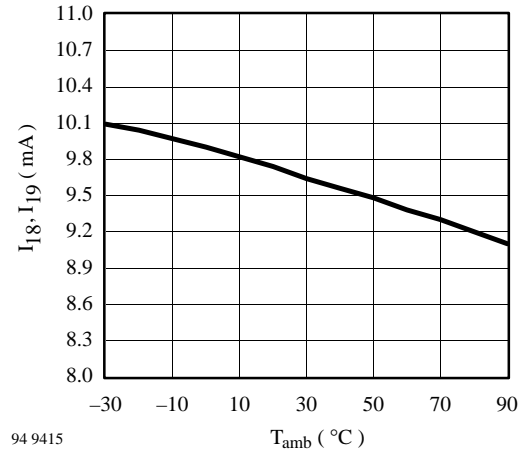

94 9415

Current of the mixer stage versus temperature

1st IF Preamplifier

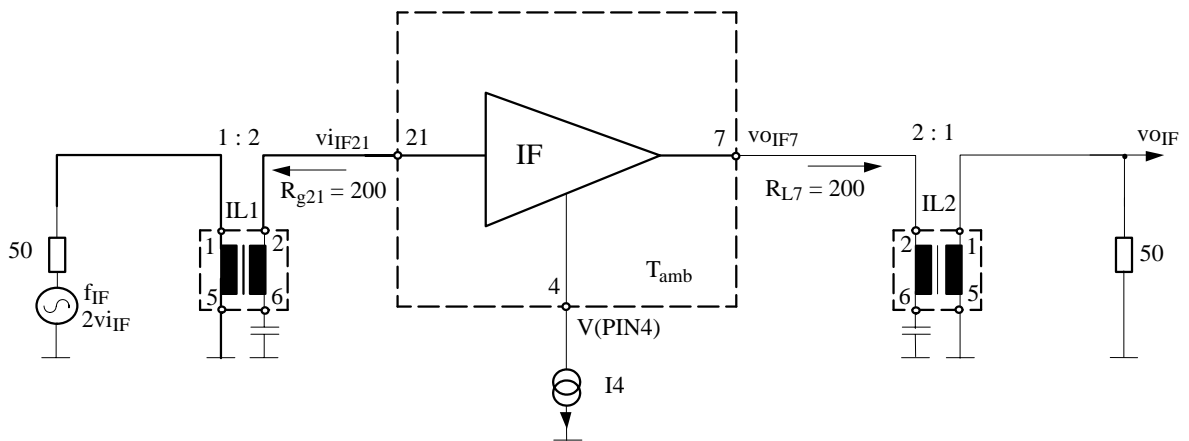

Power gain $G_{IF} = 20 \log (v_{oIF}/v_{iIF}) + IL1 \text{ (dB)} + IL2 \text{ (dB)}$
 $IL1, IL2 =$ insertion loss of the RF transformers

94 9416

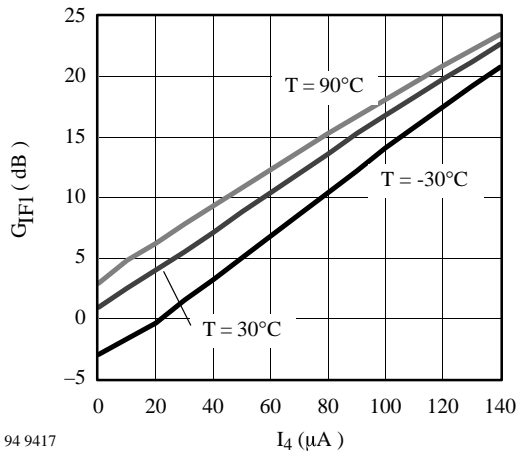

Power gain of the first IF amplifier versus I_4

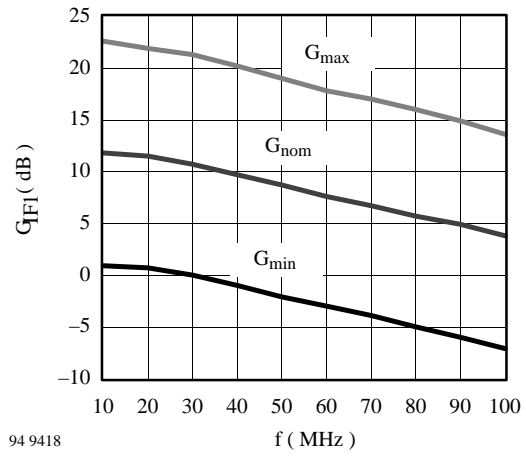

Power gain of the first IF amplifier versus frequency

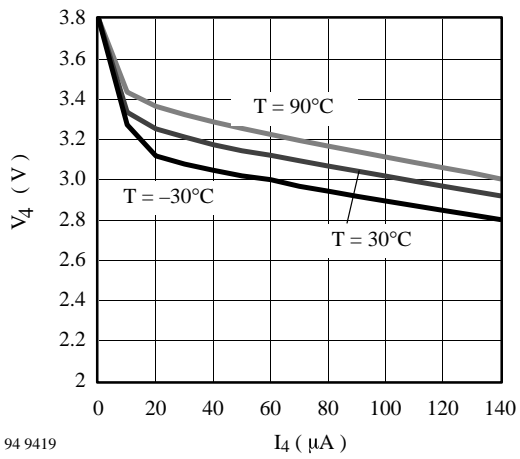

V_4 (Pin 4) versus I_4

2nd IF Preamplifier

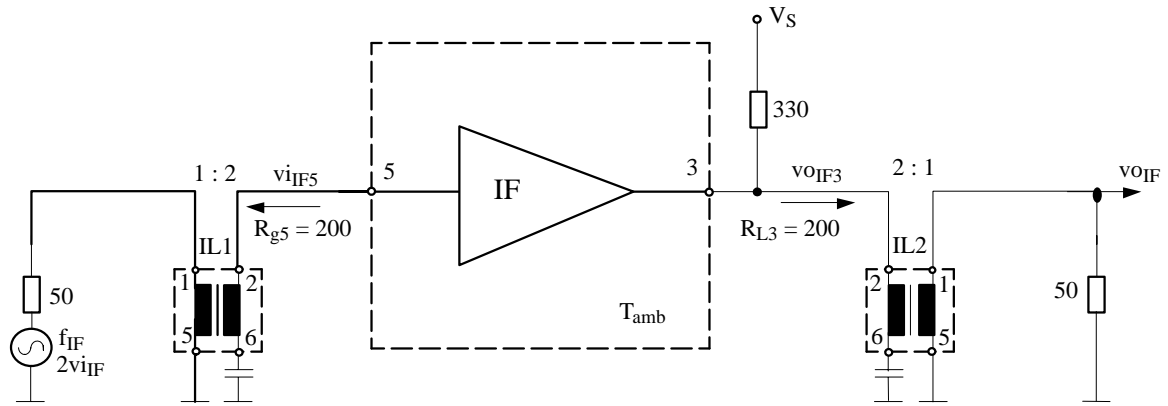

Power gain $G_{IF} = 20 \log (v_{oIF}/v_{iIF}) + IL1 \text{ (dB)} + IL2 \text{ (dB)}$
 IL1; IL2 = insertion loss of the RF transformers

94 9420

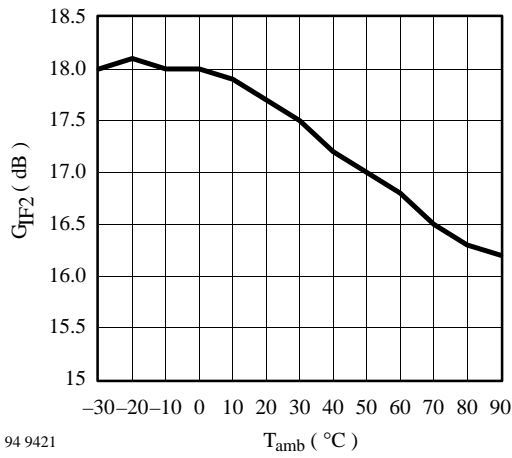

94 9421

Power gain of the second IF amplifier versus temperature

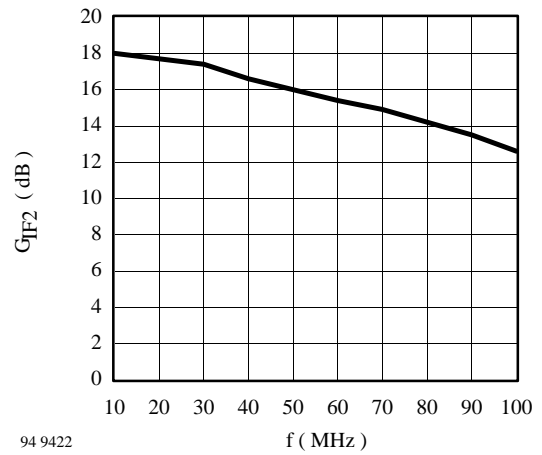

94 9422

Power gain of the second IF amplifier versus frequency

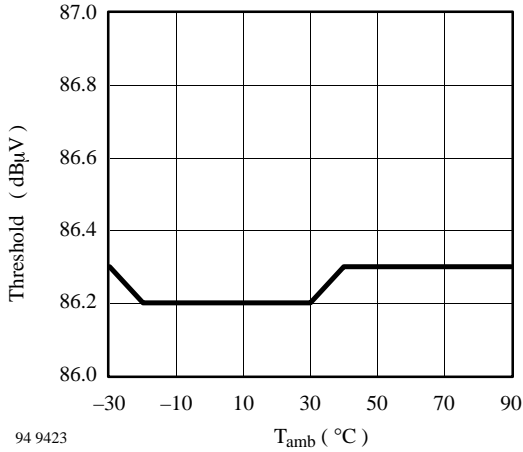

AGC threshold ($I_{I0} = 1 \mu\text{A}$) of the second IF amplifier versus temperature

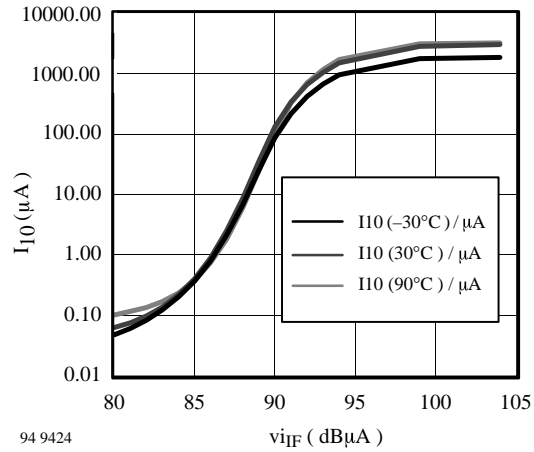

AGC characteristic of the second IF amplifier input

Interference Sensor (Mixer)

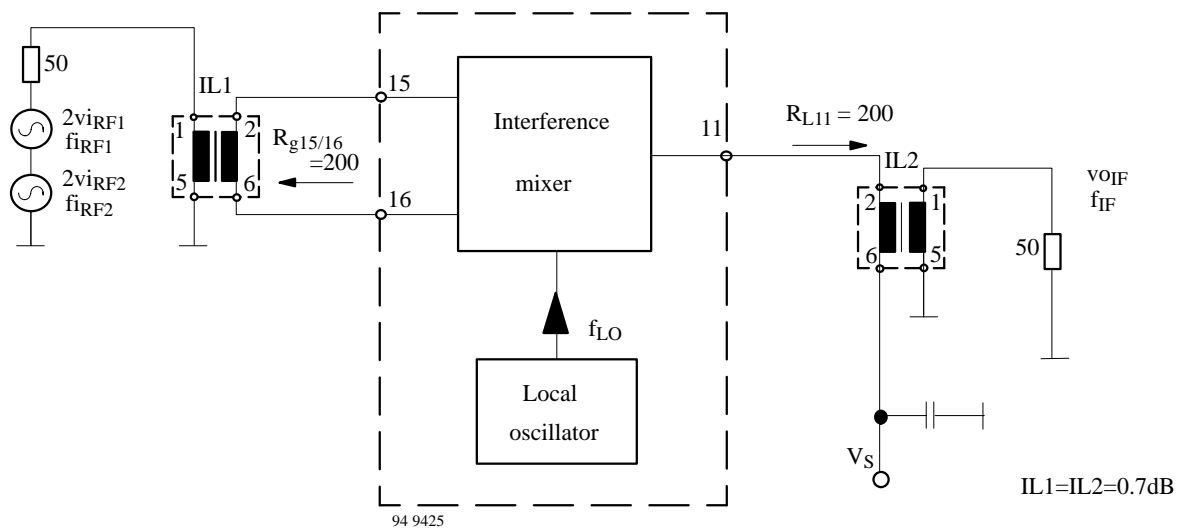

Test conditions for characteristic v_{oIF} versus v_{iRF1} :

$$f_{LO} = 100 \text{ MHz}, f_{RF1} = 89.3 \text{ MHz}, v_{iRF2} = 0, f_{IF} = f_{LO} - f_{RF1} = 10.7 \text{ MHz}$$

Test conditions for 3rd order IM-characteristic v_{oIF} versus v_{iRF1} , v_{iRF2} :

$$f_{LO} = 100 \text{ MHz}, f_{RF1} = 89.4 \text{ MHz}, f_{RF2} = 89.5 \text{ MHz}, f_{IF} = f_{LO} - (2 f_{RF1} - 1 f_{RF2}) = 10.7 \text{ MHz}$$

IL1, IL2 = insertion loss of the RF transformer

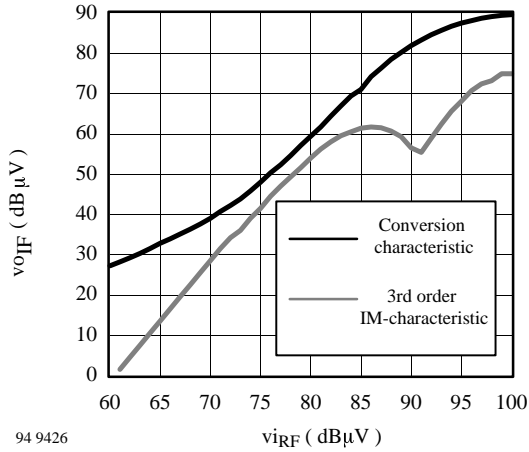

Characteristic of the interference sensor (mixer)

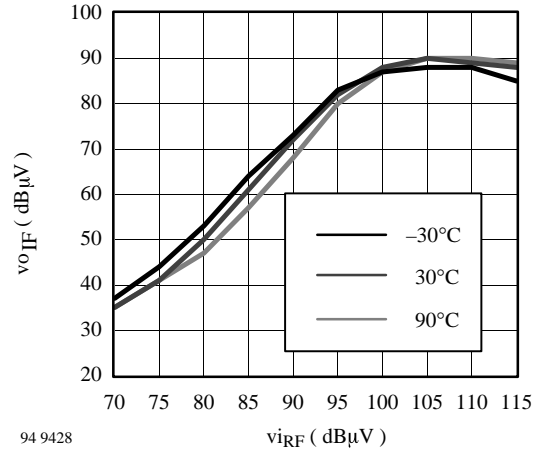

Conversion characteristic of the interference sensor (mixer)

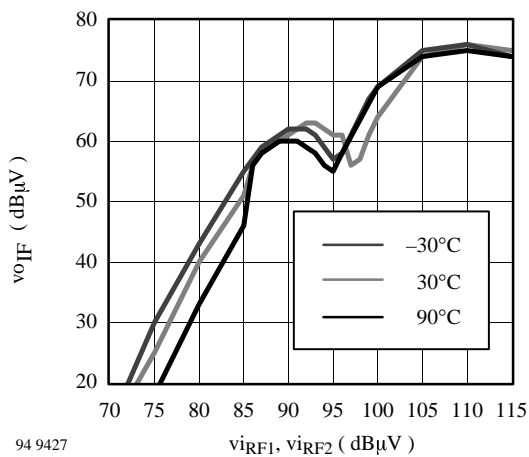

Third order interference characteristic of the interference sensor (mixer)

Interference Sensor (Amplifier)

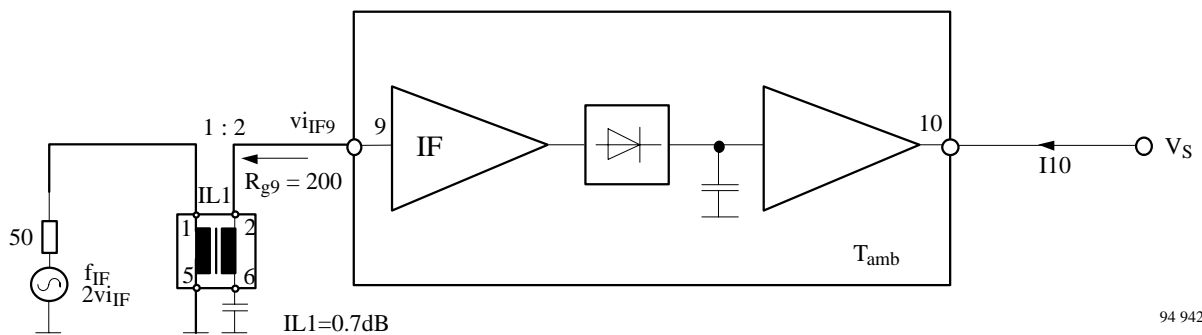

94 9429

AGC Thresholds

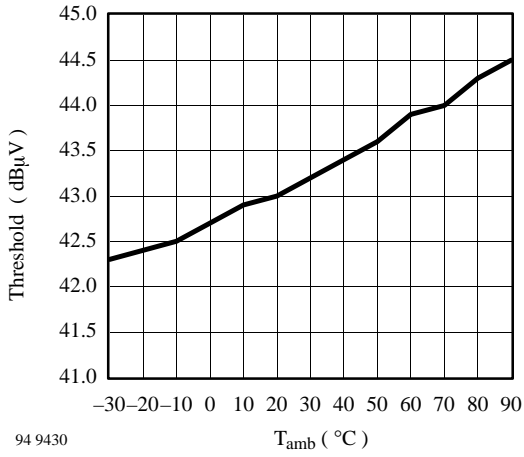

AGC threshold of the interference IF amplifier versus temperature

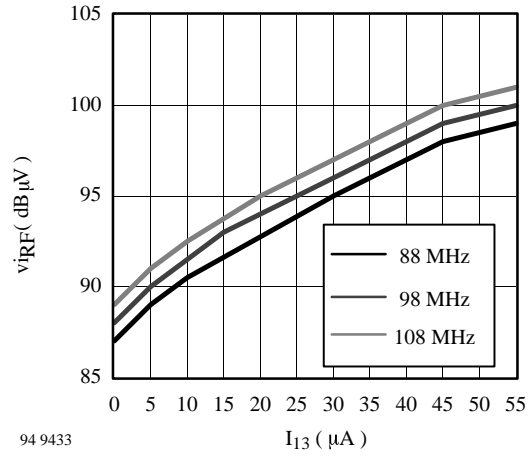

Wideband AGC threshold ($I_{10} = 1 \mu$ A) versus I_{13}

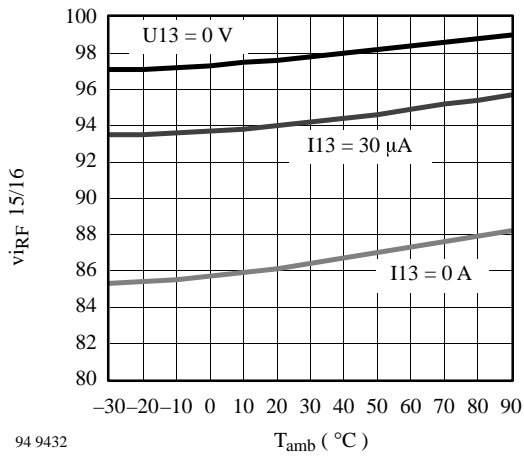

Wideband AGC threshold ($I_{10} = 1 \mu$ A) versus temperature

AGC Characteristics

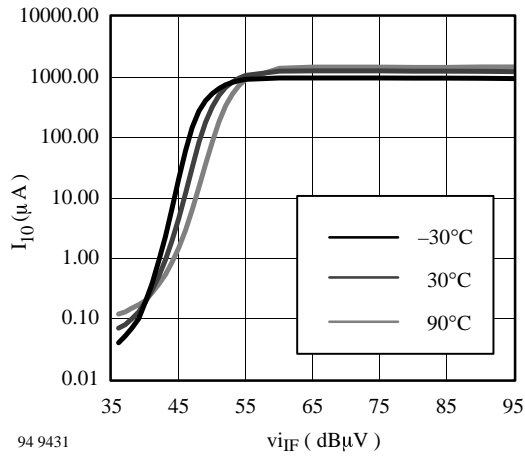

AGC characteristic of the interference IF & detector block

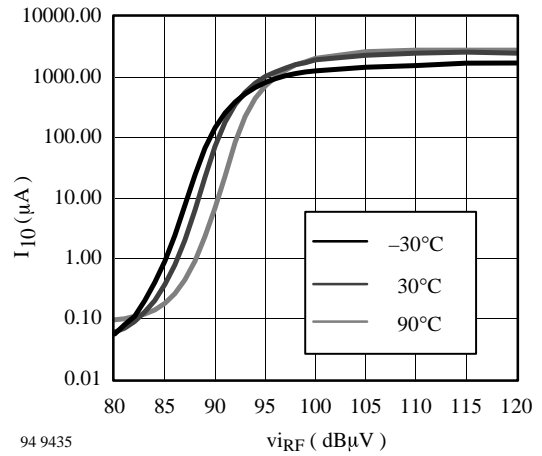

Characteristic of the wideband AGC
(I13 = 0 V)

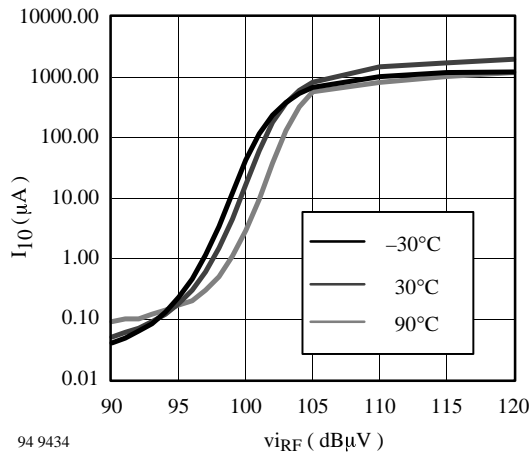

Characteristic of the wideband AGC (V13 = 0 V)

DC Characteristics

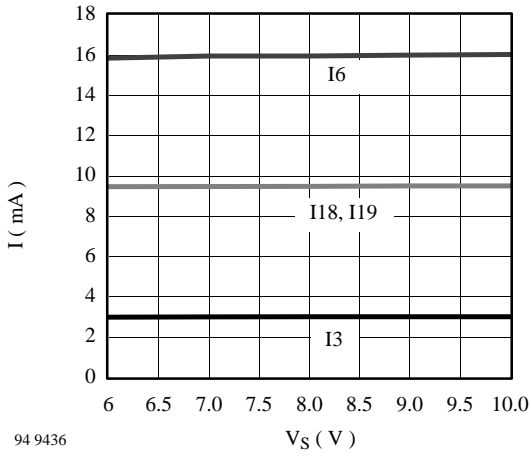

Supply currents versus supply voltage

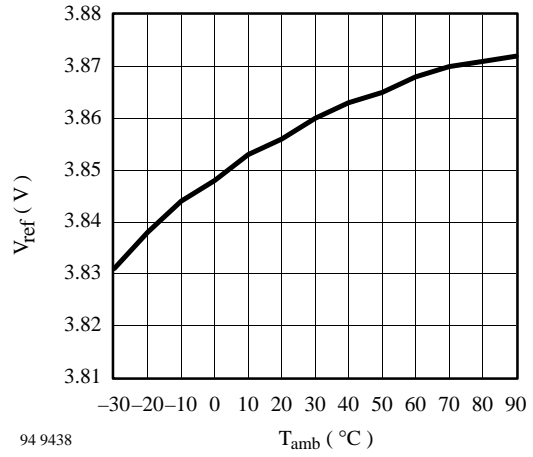

Reference voltage versus temperature

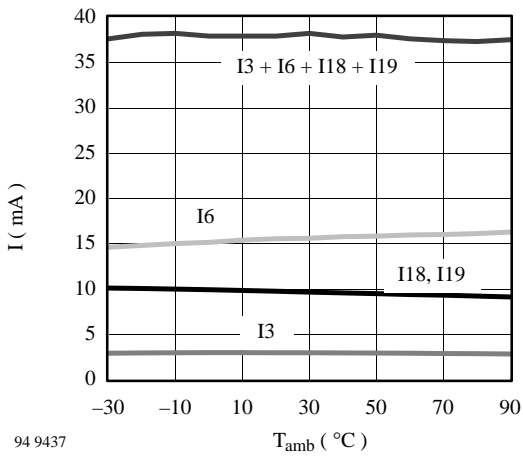

Supply currents versus temperature

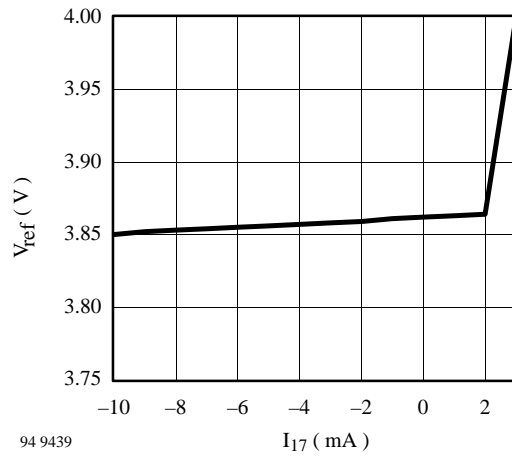

Reference voltage versus I_{17}

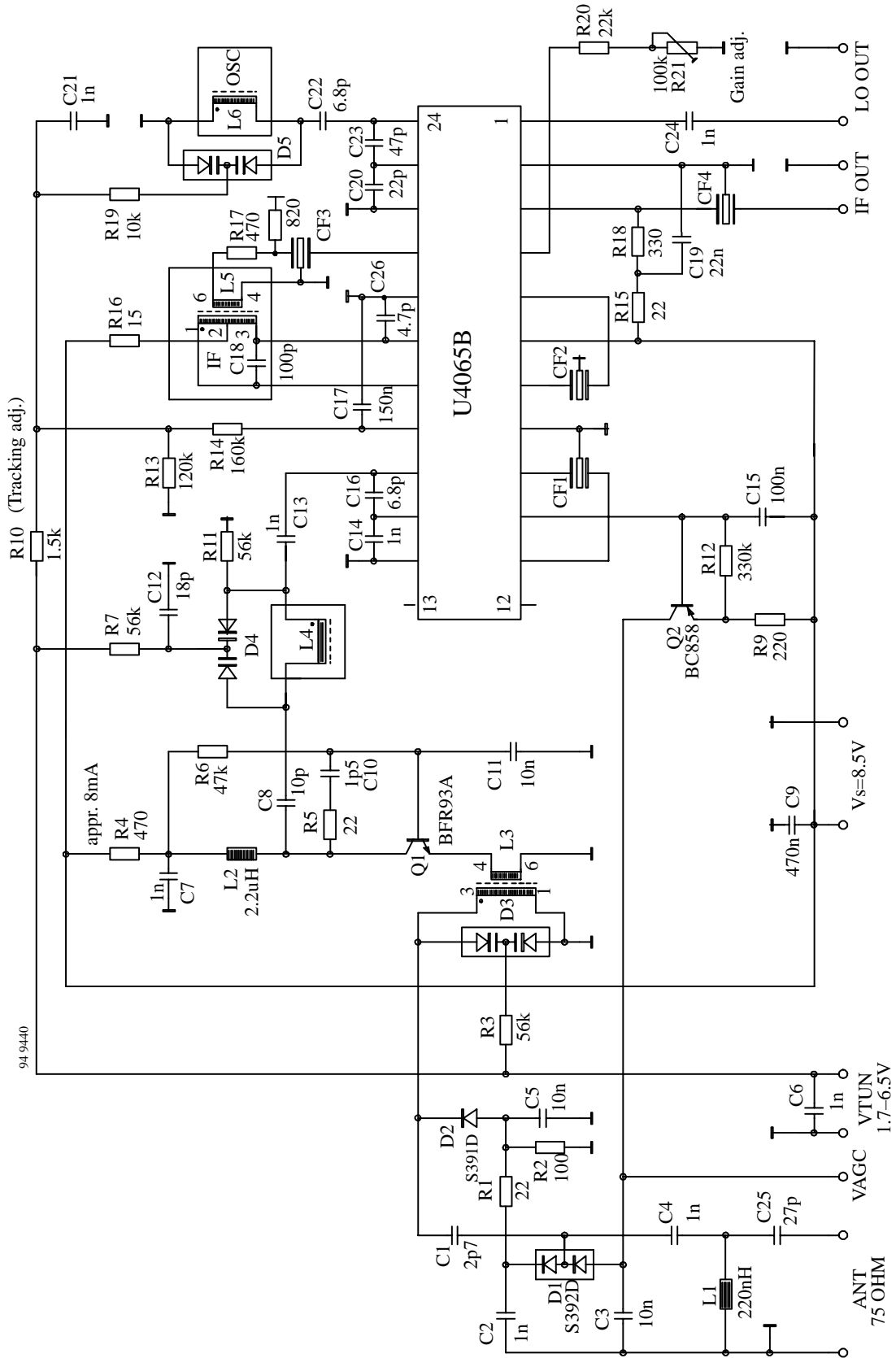

Application diagram

Part List

Item	Description
Q1	BFR93AR (BFR93A)
Q2	BC858
D1	S392D
D2	S391D
D3, 4, 5	BB804
L1	11 turns, 0.35 mm wire, 3 mm diameter (approx. 220 nH)
L2	2.2 μ H (high Q type)
L3	TOKO 7KL-type # 600ENF-7251x

Item	Description
L4	TOKO 7KL-type # 291ENS 2341IB
L5	TOKO 7KL-type # M600BCS-1397N
L6	TOKO 7KL-type # 291ENS 2054IB
CF1	TOKO type SKM 2 (230 KHZ)
CF2, 3, 4	TOKO type SKM 3 (180 KHZ)

Ordering and Package Information

Extended type number	Package	Remarks
U4065B-AFL	SO 24 plastic	
U4065B-AFLG3	SO 24 plastic	Taping according ICE-286-3

Dimensions in mm

Package SO24

Dimensions in mm

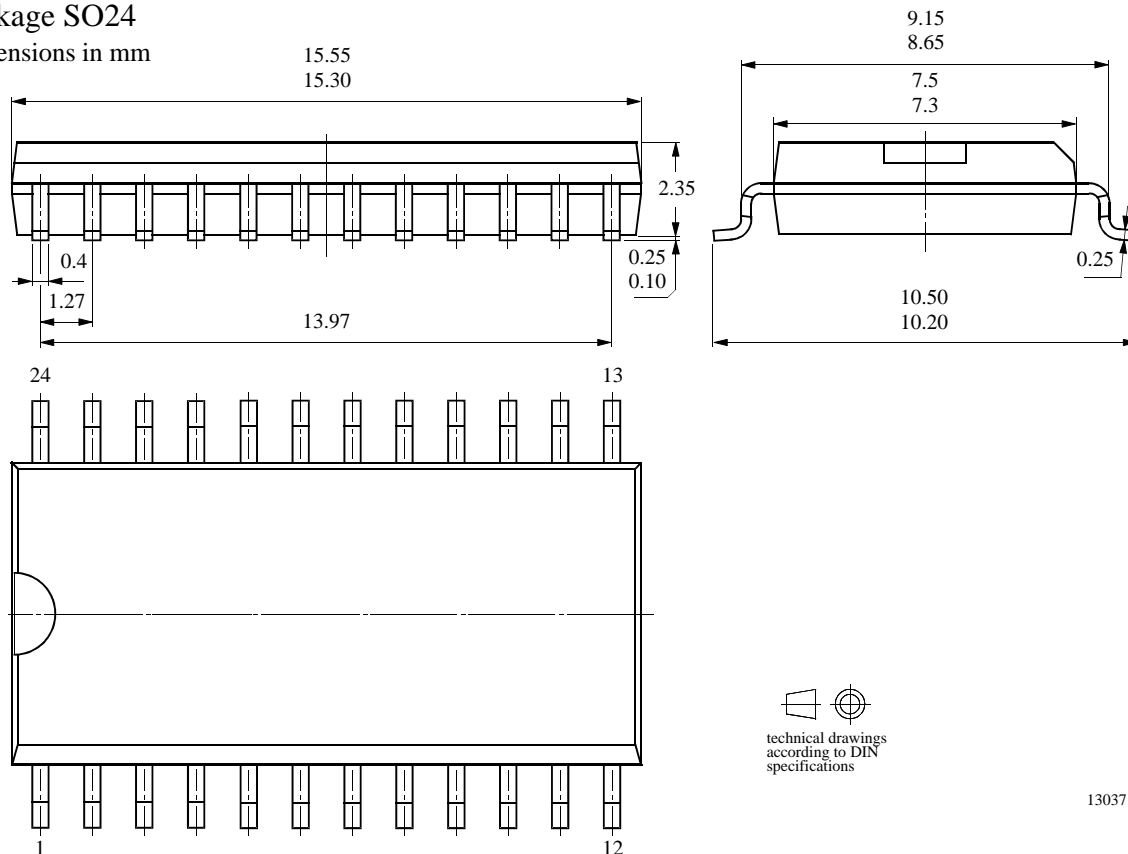

technical drawings
according to DIN
specifications

13037

Ozone Depleting Substances Policy Statement

It is the policy of **TEMIC Semiconductor GmbH** to

1. Meet all present and future national and international statutory requirements.
2. Regularly and continuously improve the performance of our products, processes, distribution and operating systems with respect to their impact on the health and safety of our employees and the public, as well as their impact on the environment.

It is particular concern to control or eliminate releases of those substances into the atmosphere which are known as ozone depleting substances (ODSs).

The Montreal Protocol (1987) and its London Amendments (1990) intend to severely restrict the use of ODSs and forbid their use within the next ten years. Various national and international initiatives are pressing for an earlier ban on these substances.

TEMIC Semiconductor GmbH has been able to use its policy of continuous improvements to eliminate the use of ODSs listed in the following documents.

1. Annex A, B and list of transitional substances of the Montreal Protocol and the London Amendments respectively
2. Class I and II ozone depleting substances in the Clean Air Act Amendments of 1990 by the Environmental Protection Agency (EPA) in the USA
3. Council Decision 88/540/EEC and 91/690/EEC Annex A, B and C (transitional substances) respectively.

TEMIC Semiconductor GmbH can certify that our semiconductors are not manufactured with ozone depleting substances and do not contain such substances.

We reserve the right to make changes to improve technical design and may do so without further notice.

Parameters can vary in different applications. All operating parameters must be validated for each customer application by the customer. Should the buyer use TEMIC products for any unintended or unauthorized application, the buyer shall indemnify TEMIC against all claims, costs, damages, and expenses, arising out of, directly or indirectly, any claim of personal damage, injury or death associated with such unintended or unauthorized use.

TEMIC Semiconductor GmbH, P.O.B. 3535, D-74025 Heilbronn, Germany
Telephone: 49 (0)7131 67 2594, Fax number: 49 (0)7131 67 2423