

## Automotive Lamp Outage Monitor, $V_T = 53\text{ mV}$

### Description

The monolithic integrated bipolar circuit, U4791B, is designed as a monitor for lamp failure in automobiles. The comparator threshold is matched to the PTC characteristic of incandescent lamps. The threshold is tied to a typical value of  $V_{4,6} = V_S - V_T$  whereas  $V_T = 53\text{ mV}$ .

The integrated circuit is recommended for the application of parallel connected lamps. If the voltage drop across shunt resistor,  $R_{sh}$ , exceeds  $53\text{ mV}$ , the output is turned off, otherwise the output is turned on. Without supply voltage or open input Pin 8 the output is turned off.

A not used comparator must be connected to Pin 7.

### Features

- 10 kV-ESD protection
- Two comparators with common reference
- Tight threshold tolerance
- Threshold matched to PTC characteristic of incandescent lamps
- Temperature compensated
- NPN output
- Interference and damage-protection according to VDE 0839
- EMI protection
- Reversal polarity protection
- Load-dump protection

### Ordering Information

Extended Type Number	Package	Remarks
U4791B	DIP8	
U4791B-FP	SO8	

### Block Diagram

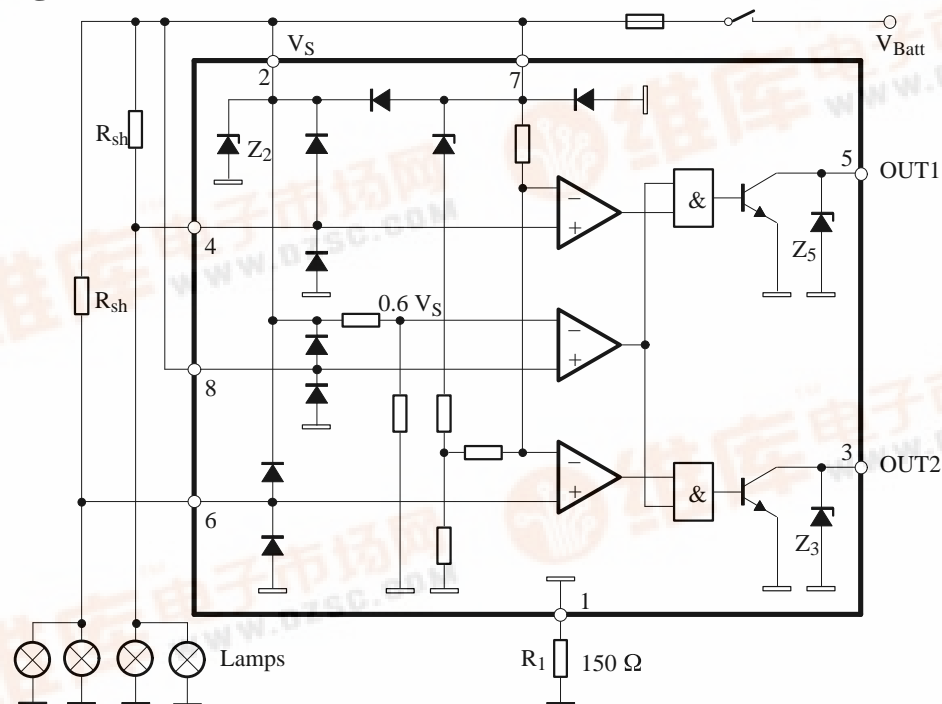

95 10613

Figure 1. Schematic and application circuit

## Pin Description

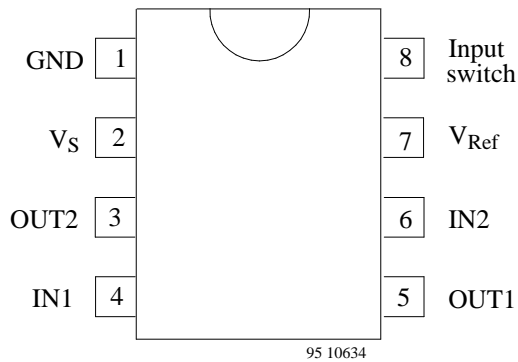

Pin	Symbol	Function
1	GND	Reference point, ground
2	$V_S$	Supply voltage
3	OUT2	Output 2
4	IN1	Input 1
5	OUT1	Output 1
6	IN2	Input 2
7	$V_{Ref}$	Reference voltage
8	Input	Input switch

## Absolute Maximum Ratings

Parameters	Symbol	Value	Unit
Supply voltage	$V_S$	16.5	V
Current consumption $t = 2$ ms, measured at Pin 1 (GND)	$I_1$	1.5	A
Output current	$I_{3,5}$	20	mA
Input voltage reference point Pin 7	$-V_{4,6}$	6	V
Power dissipation $T_{amb} = 95$ °C	$P_{tot}$	DIP 8	420
		SO 8	360
$T_{amb} = 60$ °C	$P_{tot}$	DIP 8	690
		SO 8	560
Ambient temperature range	$T_{amb}$	-40 to +95	°C
Storage temperature range	$T_{stg}$	-55 to +125	°C
Junction temperature	$T_j$	150	°C

## Thermal Resistance

Parameters	Symbol	Value	Unit
Junction ambient	$R_{thJA}$	110	K/W
	$R_{thJA}$	160	K/W

**Electrical Characteristics**

$V_S = 9$  to  $15$  V,  $T_{amb} = -40$  to  $+95$  °C, figure 1, unless otherwise specified

Parameters	Test Conditions / Pin	Symbol	Min	Typ	Max	Unit
Supply voltage	Pin 2,7	$V_S$	9		15	V
Internal Z-diode $Z_2$	Pin 2	$V_Z$	20			V
Current consumption	$V_S = 12$ V Pin 1 measured at Pin 1 (GND)	$I_1$		4.5	6	mA
Output saturation voltage	$V_S = 9$ V, $I_{3,5} = 10$ mA $T_{amb} = 25$ °C Pin 3,5	$V_{sat}$			0.5	V
Output Z-diodes $Z_3, Z_5$	Pin 3,5	$V_Z$	21			V
Control signal threshold	Reference point Pin 7 ( $V_7$ ) $I_{3,5} = 1$ mA Pin 4,6 $V_S = 12$ V $V_S = 15$ V	$-V_T$	51.5 57	53.5 59	55.5 61	mV
Voltage drift $\Delta V = \frac{V_{T(15V)} - V_{T(12V)}}{15\text{ V} - 12\text{ V}}$	Pin 4,6	$\Delta V$		1.8		mV/V
Threshold voltage	Switch identification Pin 8	$V_8$		$0.6 V_S$		V
Input currents	Pin 4,6	$I_I$		100		nA
	Pin 8			5		$\mu$ A
Delay time	Switch-on High to low Pin 3,5	$t_{d(on)}$		6		$\mu$ s
	Switch-off Low to high		$t_{d(off)}$		30	

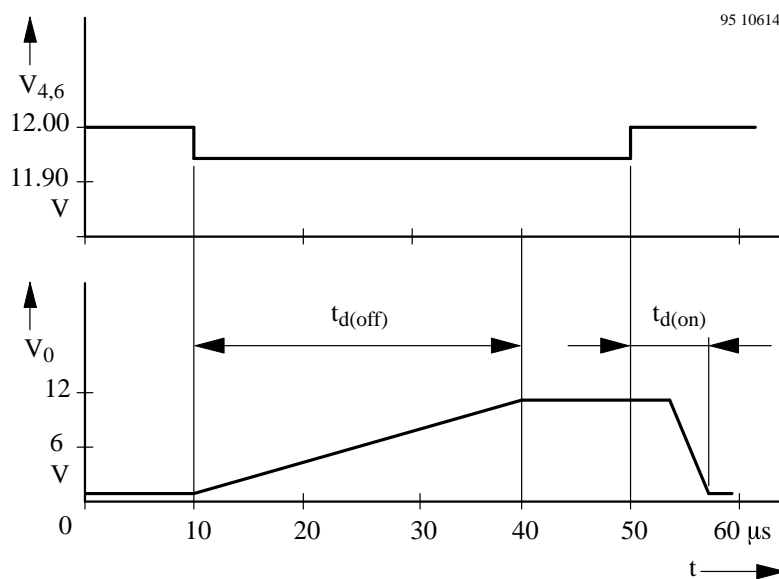

Figure 2.

# U4791B

## Package Information

### Package DIP8

Dimensions in mm

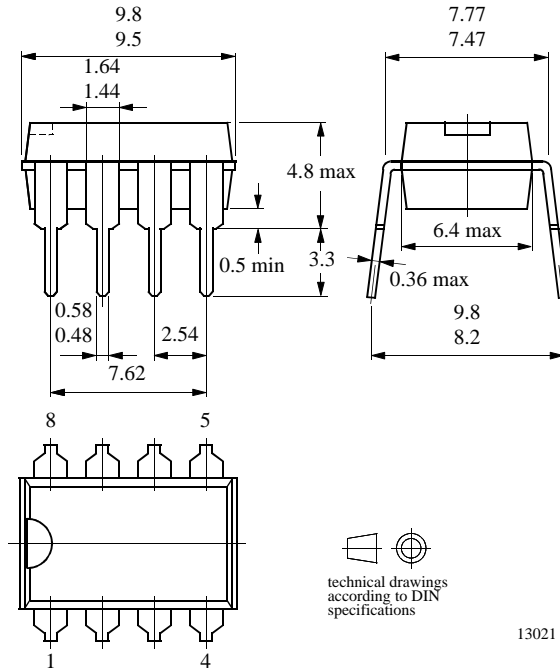

### Package SO8

Dimensions in mm

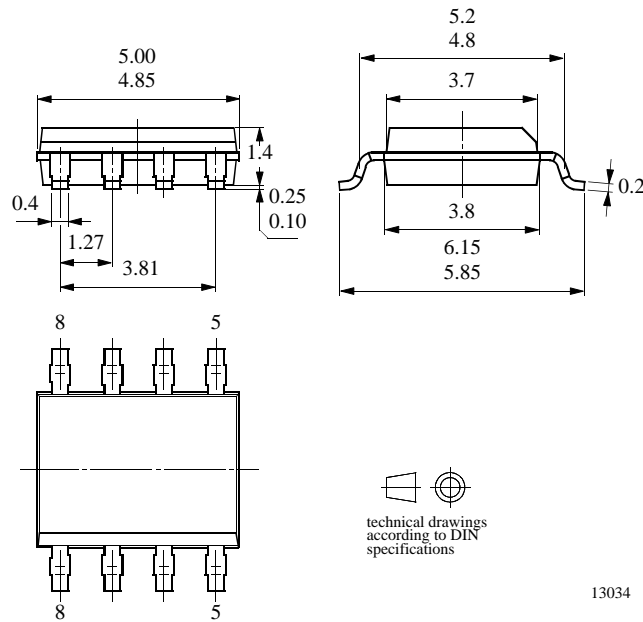

## **Ozone Depleting Substances Policy Statement**

It is the policy of **TEMIC TELEFUNKEN microelectronic GmbH** to

1. Meet all present and future national and international statutory requirements.
2. Regularly and continuously improve the performance of our products, processes, distribution and operating systems with respect to their impact on the health and safety of our employees and the public, as well as their impact on the environment.

It is particular concern to control or eliminate releases of those substances into the atmosphere which are known as ozone depleting substances (ODSs).

The Montreal Protocol (1987) and its London Amendments (1990) intend to severely restrict the use of ODSs and forbid their use within the next ten years. Various national and international initiatives are pressing for an earlier ban on these substances.

**TEMIC TELEFUNKEN microelectronic GmbH** semiconductor division has been able to use its policy of continuous improvements to eliminate the use of ODSs listed in the following documents.

1. Annex A, B and list of transitional substances of the Montreal Protocol and the London Amendments respectively
2. Class I and II ozone depleting substances in the Clean Air Act Amendments of 1990 by the Environmental Protection Agency (EPA) in the USA
3. Council Decision 88/540/EEC and 91/690/EEC Annex A, B and C (transitional substances) respectively.

**TEMIC** can certify that our semiconductors are not manufactured with ozone depleting substances and do not contain such substances.

**We reserve the right to make changes to improve technical design and may do so without further notice.**

Parameters can vary in different applications. All operating parameters must be validated for each customer application by the customer. Should the buyer use TEMIC products for any unintended or unauthorized application, the buyer shall indemnify TEMIC against all claims, costs, damages, and expenses, arising out of, directly or indirectly, any claim of personal damage, injury or death associated with such unintended or unauthorized use.

TEMIC TELEFUNKEN microelectronic GmbH, P.O.B. 3535, D-74025 Heilbronn, Germany  
Telephone: 49 (0)7131 67 2831, Fax number: 49 (0)7131 67 2423