

## Features

- Digital Self-supervising Watchdog with Hysteresis
- One 250-mA Output Driver for Relay
- Enable Output Open Collector 8 mA
- Over/Undervoltage Detection
- ENABLE and RELAY Outputs Protected Against Standard Transients and 40 V Load Dump
- ESD Protection According to MIL-STD-883 D Test Method 3015.7
  - Human Body Model:  $\pm 2$  kV (100 pF, 1.5 k $\Omega$ )
  - Machine Model:  $\pm 200$  V (200 pF, 0  $\Omega$ )

## Description

The U6808B is designed to support the fail-safe function of a safety critical system (e.g., ABS). It includes a relay driver, a watchdog controlled by an external R/C-network and a reset circuit initiated by an over and undervoltage condition of the 5-V supply providing a low-level reset signal.

Figure 1. Block Diagram

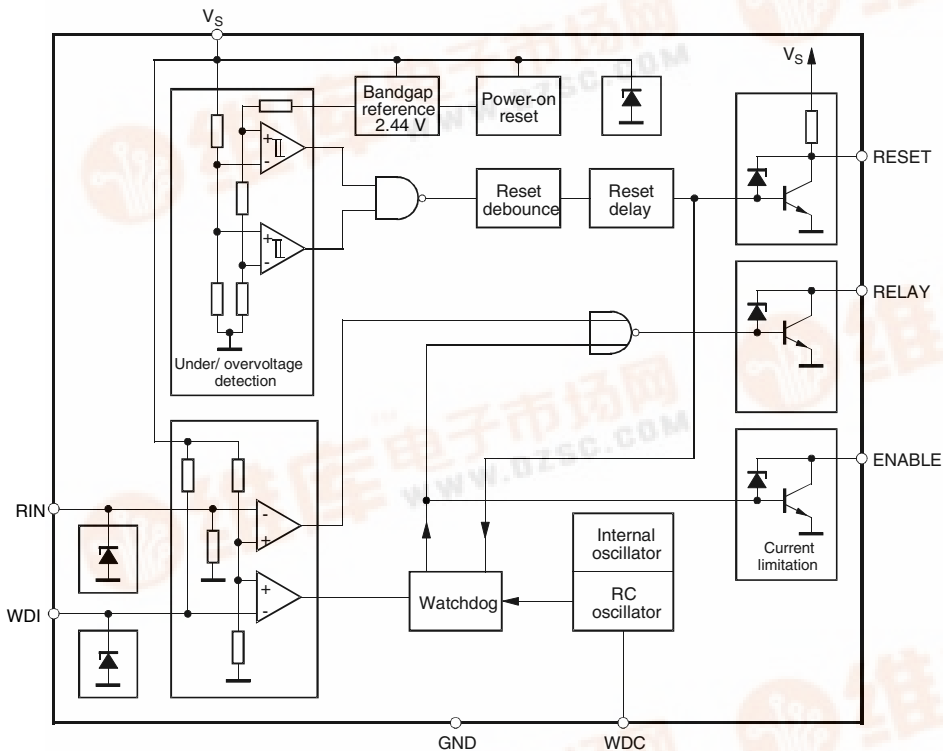

## Special Fail-safe IC

## U6808B



## Pin Configuration

Figure 2. Pinning SO8

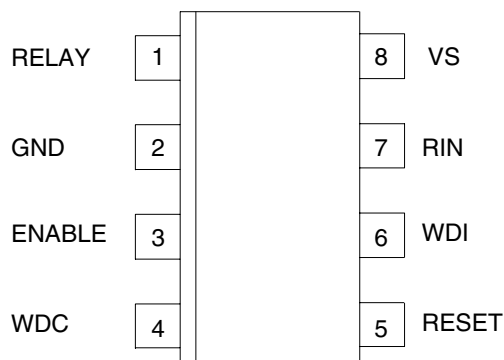

## Pin Description

Pin	Symbol	Type	Function	Logic
1	RELAY	Open collector driver output	Fail-safe relay driver	No signal: driver off Low: driver on
2	GND	Supply	Standard ground	No signal
3	ENABLE	Digital output	Negative reset signal	Low: reset
4	WDC	Analog input	External RC for watchdog timer	No signal
5	RESET	Digital output	Negative reset signal	Low: reset
6	WDI	Digital input	Watchdog trigger signal	Pulse sequence
7	RIN	Digital input	Activation of relay driver	High: driver on Low: driver off
8	VS	Supply	5-V supply	–

## Fail-safe Functions

A fail-safe IC has to maintain its monitoring function even if there is a fault condition at one of the pins (e.g., short circuit). This ensures that a microcontroller system is not brought into a critical status. A critical status is reached if the system is not able to switch off the relay and to give a signal to the microcontroller via the ENABLE and RESET outputs. The following table shows the fault conditions for the pins.

Table 1. Table of Fault Conditions

Pin	Function	Short to Vs	Short to VBat	Short to GND	Open Circuit
RIN	Digital input to activate the fail-safe relay	Relay on	Relay on	Relay off	Relay off
WDI	Watchdog trigger input	Watchdog reset	Watchdog reset	Watchdog reset	Watchdog reset
OSC	Capacitor and resistor of watchdog	Watchdog reset	Watchdog reset	Watchdog reset	Watchdog reset
RELAY	Driver of the fail-safe relay			Relay on	Relay off

Truth Tables

**Table 2.** Truth Table for Over and Undervoltage Conditions

Supply Voltage (V <sub>S</sub> )	Relay Input (RIN)	Relay Output Driver (RELAY)	RESET Output (RESET)	Enable Output Driver (ENABLE)
Normal	Low	Off	High	Off
	High	On	High	Off
Too low	Low	Off	Low	On
	High	Off	Low	On
Too high	Low	Off	Low	On
	High	Off	Low	On

**Table 3.** Truth Table for Watchdog Failures (Reset Output Do Not Care)

Watchdog Input (WDI)	Relay Input (RIN)	Relay Output Driver (RELAY)	Enable Output Driver (ENABLE)
Normal	Low	Off	Off
	High	On	Off
Too slow	Low	Off	On
	High	Off	On
Too fast	Low	Off	On
	High	Off	On

Description of the Watchdog

**Figure 3.** Watchdog Block Diagram

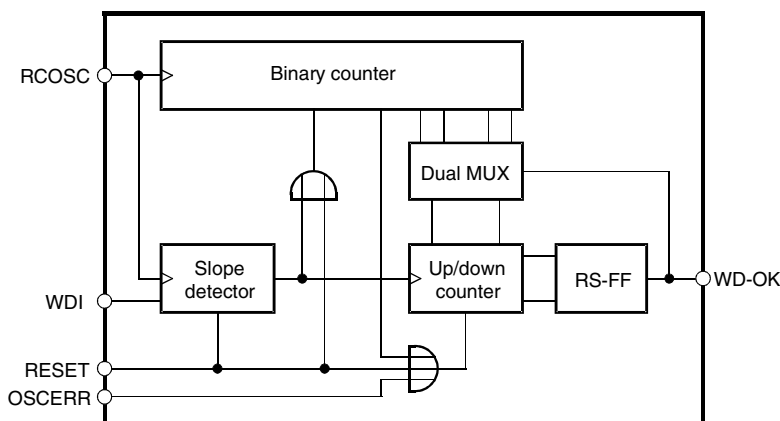

Abstract

The microcontroller is monitored by a digital window watchdog which accepts an incoming trigger signal of a constant frequency for correct operation. The frequency of the trigger signal can be varied in a broad range as the watchdog's time window is determined by external R/C components. The following description refers to the block diagram, see Figure 3.



## WDI Input

The microcontroller has to provide a trigger signal with the frequency  $f_{WDI}$  which is fed to the WDI input. A positive edge of  $f_{WDI}$  detected by a slope detector resets the binary counter and clocks the up/down counter additionally. The latter one counts only from 0 to 3 or reverse. Each correct trigger increments the up/down counter by 1, each wrong trigger decrements it by 1. As soon as the counter reaches status 3 the RS flip-flop is set (see Figure 4). A missing incoming trigger signal is detected after 250 clocks of the internal watchdog frequency  $f_{RC}$  (see section "WD-OK Output") and resets the up/down counter directly.

## RCOSC Input

With an external R/C circuitry the IC generates a time base (frequency  $f_{WDC}$ ) independent from the microcontroller. The watchdog's time window refers to a frequency of

$$f_{WDC} = 100 \times f_{WDI}$$

## OSCERR Input

A smart watchdog has to ensure that internal problems with its own time base are detected and do not lead to an undesired status of the complete system. If the RC oscillator stops oscillating a signal is fed to the OSCERR input after a timeout delay. It resets the up/down counter and disables the WD-OK output.

Without this reset function the watchdog would freeze in its current status when  $f_{RC}$  stops.

## RESET Input

During power-on and under/overvoltage detection a reset signal is fed to this pin. It resets the watchdog timer and sets the initial state.

## WD-OK Output

After the up/down counter is incremented to status 3 (see Figure 4) the RS flip-flop is set and the WD-OK output becomes logic 1. This information is available for the microcontroller at the open-collector output ENABLE. If on the other hand the up/down counter is decremented to 0 the RS flip-flop is reset, the WD-OK output and the ENABLE output are disabled. The WD-OK output also controls a dual MUX stage which shifts the time window by one clock after a successful trigger, thus forming a hysteresis to provide stable conditions for the evaluation of the trigger signal good or false. The WD-OK signal is also reset in case the watchdog counter is not reset after 250 clocks (missing trigger signal).

Watchdog State Diagram Figure 4. Watchdog State Diagram

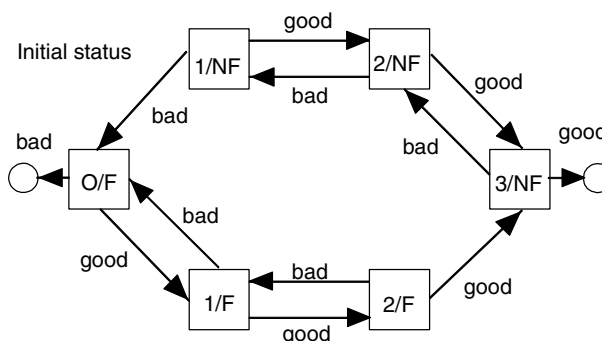

**Explanation**

In each block, the first character represents the state of the counter. The second notation indicates the fault status of the counter. A fault status is indicated by an F and a no fault status is indicated by an NF. When the watchdog is powered up initially, the counter starts out at the 0/F block (initial state). Good indicates that a pulse has been received whose width resides within the timing window. Bad indicates that a pulse has been received whose width is either too short or too long.

**Watchdog Window Calculation**

**Example with Recommended Values**

$C_{osc} = 3.3 \text{ nF}$  (should be preferably 10%, NPO)  
 $R_{osc} = 39 \text{ k}\Omega$  (may be 5%,  $R_{osc} < 100 \text{ k}\Omega$  due to leakage current and humidity)

**RC Oscillator**

$$t_{WDC}(s) = 10^{-3} \times [C_{osc} \text{ (nF)} \times [(0.00078 \times R_{osc} \text{ (k}\Omega\text{)}) + 0.0005]]$$

$$f_{WDC}(\text{Hz}) = 1/(t_{WDC})$$

**Watchdog WDI**

$$f_{WDI}(\text{Hz}) = 0.01 \times f_{WDC}$$

$$t_{WDC} = 100 \mu\text{s} \rightarrow f_{WDC} = 10 \text{ kHz}$$

$$f_{WDI} = 100 \text{ Hz} \rightarrow t_{WDI} = 10 \text{ ms}$$

*WDI Pulse Width for Fault Detection after 3 Pulses*

Upper watchdog window  
 Minimum:  $169/f_{WDC} = 16.9 \text{ ms} \rightarrow f_{WDC}/169 = 59.1 \text{ Hz}$   
 Maximum:  $170/f_{WDC} = 17.0 \text{ ms} \rightarrow f_{WDC}/170 = 58.8 \text{ Hz}$   
 Lower watchdog window  
 Minimum:  $79/f_{WDC} = 7.9 \text{ ms} \rightarrow f_{WDC}/79 = 126.6 \text{ Hz}$   
 Maximum:  $80/f_{WDC} = 8.0 \text{ ms} \rightarrow f_{WDC}/80 = 125.0 \text{ Hz}$

*WDI Dropouts for Immediate Fault Detection*

Minimum:  $250/f_{WDC} = 25 \text{ ms}$   
 Maximum:  $251/f_{WDC} = 25.1 \text{ ms}$

**Figure 5. Watchdog Timing Diagram with Tolerances**

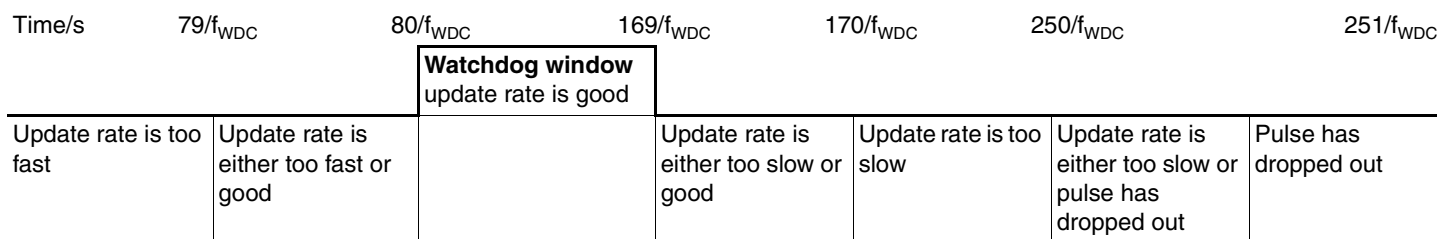

*Reset Delay*

The duration of the over or undervoltage pulses determines the enable and reset output. A pulse duration shorter than the debounce time has no effect on the outputs. A pulse longer than the debounce time results in the first reset delay. If a pulse appears during this delay, a second delay time is triggered. Therefore, the total reset delay time can be longer than specified in the data sheet.



## Absolute Maximum Ratings

Parameters	Symbol	Value	Unit
Supply-voltage range	$V_S$	-0.2 to +16	V
Power dissipation $V_S = 5\text{ V}$ , $T_{\text{amb}} = -40^\circ\text{C}$ $V_S = 5\text{ V}$ , $T_{\text{amb}} = +125^\circ\text{C}$	$P_{\text{tot}}$ $P_{\text{tot}}$	250 150	mW mW
Thermal resistance	$R_{\text{thja}}$	160	K/W
Junction temperature	$T_j$	150	$^\circ\text{C}$
Ambient temperature range	$T_{\text{amb}}$	-40 to +125	$^\circ\text{C}$
Storage temperature range	$T_{\text{stg}}$	-55 to +155	$^\circ\text{C}$

## Electrical Characteristics

$V_S = 5\text{ V}$ ,  $T_{\text{amb}} = -40$  to  $+125^\circ\text{C}$ , reference pin is GND,  $f_{\text{intern}} = 100\text{ kHz} + 50\% - 45\%$ ,  $f_{\text{WDC}} = 10\text{ kHz} \pm 10\%$ ,  $f_{\text{WDI}} = 100\text{ Hz}$

Parameters	Test Conditions	Symbol	Min.	Typ.	Max.	Unit
<b>Supply Voltage</b>						
Operation range general		$V_S$	4.5		5.5	V
Operation range reset		$V_S$	1.2		16.0	V
<b>Supply Current</b>						
Relay off	$T_{\text{amb}} = -40^\circ\text{C}$ $T_{\text{amb}} = +125^\circ\text{C}$				6	mA mA
Relay on	$T_{\text{amb}} = -40^\circ\text{C}$ $T_{\text{amb}} = +125^\circ\text{C}$				15	mA mA
<b>Digital Input WDI</b>						
Detection low			-0.2		$0.2 \times V_S$	V
Detection high			$0.7 \times V_S$		$V_S + 0.5\text{ V}$	V
Resistance to $V_S$			10		40	$\text{k}\Omega$
Input current low	Input voltage = 0 V		100		550	$\mu\text{A}$
Input current high	Input voltage = $V_S$		-5		+5	$\mu\text{A}$
Zener clamping voltage		$V_{\text{ZWDI}}$	20		24	V
<b>Digital Input RIN</b>						
Detection low			-0.2		$0.2 \times V_S$	V
Detection high			$0.7 \times V_S$		$V_S + 0.5\text{ V}$	V
Resistance to GND			10		40	$\text{k}\Omega$
Input current low	Input voltage = 0 V		-5		+5	$\mu\text{A}$
Input current high	Input voltage = $V_S$		100		550	$\mu\text{A}$
Zener clamping voltage		$V_{\text{ZRIN}}$	20		24	V
<b>Digital Output RESET with Internal Pull-up</b>						
Voltage high	Pull-up = 6 $\text{k}\Omega$		$0.7 \times V_S + 0.1$		$V_S$	V
Voltage low	$I \leq 1\text{ mA}$ $1.2\text{ V} < V_S < 16\text{ V}$		0		0.3	V
Zener clamping voltage		$V_{\text{ZRESET}}$	26		30	V
Reset debounce time	Switch to low	$t_{\text{deb}}$	120	320	500	$\mu\text{s}$

## Electrical Characteristics (Continued)

$V_S = 5\text{ V}$ ,  $T_{\text{amb}} = -40\text{ to }+125^\circ\text{C}$ , reference pin is GND,  $f_{\text{intern}} = 100\text{ kHz} + 50\% - 45\%$ ,  $f_{\text{WDC}} = 10\text{ kHz} \pm 10\%$ ,  $f_{\text{WDI}} = 100\text{ Hz}$

Parameters	Test Conditions	Symbol	Min.	Typ.	Max.	Unit
Reset delay time	Switch back to high	$t_{\text{del}}$		50		ms
<b>Digital Output ENABLE with Open Collector</b>						
Saturation voltage low	$I \leq 8\text{ mA}$		0.01		0.5	V
Zener clamping voltage		$V_{\text{ZEN}}$	26		30	V
Current limitation		$I_{\text{lim}}$	8			mA
Leakage current	$V_{\text{EN}} = 5\text{ V}$	$I_{\text{EN5}}$			20	$\mu\text{A}$
	$V_{\text{EN}} = 16\text{ V}$	$I_{\text{EN16}}$			100	$\mu\text{A}$
	$V_{\text{EN}} = 26\text{ V}$	$I_{\text{EN26}}$			200	$\mu\text{A}$
Reset debounce time	Switch to low	$t_{\text{deb}}$	120	320	500	$\mu\text{s}$
Reset delay time	Switch back to high	$t_{\text{del}}$		85		ms
<b>Relay Driver Output RELAY</b>						
Saturation voltage	$I \leq 250\text{ mA}$	$V_{\text{RSat}}$			0.5	V
	$I \leq 130\text{ mA}$	$V_{\text{RSat}}$			0.3	V
Maximum load current	$T_{\text{amb}} = -40\text{ to }+90^\circ\text{C}$	$I_{\text{R}}$	250			mA
	$T_{\text{amb}} > 90^\circ\text{C}$	$I_{\text{R}}$	200			mA
Zener clamping voltage		$V_{\text{ZR}}$	26		30	V
Turn-off energy			30			mJ
Leakage current	$V_{\text{R}} = 16\text{ V}$	$I_{\text{R16}}$			20	$\mu\text{A}$
	$V_{\text{R}} = 26\text{ V}$	$I_{\text{R26}}$			200	$\mu\text{A}$
<b>Reset and <math>V_S</math> Control</b>						
Lower reset level		$V_S$	4.5		4.7	V
Upper reset level		$V_S$	5.35		5.6	V
Hysteresis			25		100	mV
Reset debounce time			120	320	500	$\mu\text{s}$
Reset delay			20	50	80	ms
<b>RC Oscillator WDC</b>						
Oscillator frequency	$R_{\text{OSC}} = 39\text{ k}\Omega$ , $C_{\text{OSC}} = 3.3\text{ nF}$	$f_{\text{WDC}}$	9	10	11	kHz
<b>Watchdog Timing</b>						
Power-on-reset prolongation time		$t_{\text{POR}}$	34.3		103.1	ms
Detection time for RC oscillator fault	$V_{\text{RC}} = \text{const.}$	$t_{\text{RCerror}}$	81.9		246	ms
Time interval for over-/undervoltage detection		$t_{\text{D,OUV}}$	0.16		0.64	ms
Reaction time of RESET output over/undervoltage		$t_{\text{R,OUV}}$	0.187		0.72	ms
Nominal frequency for WDI	$f_{\text{RC}} = 100 \times f_{\text{WDI}}$	$f_{\text{WDI}}$	10		130	Hz
Nominal frequency for WDC	$f_{\text{WDI}} = 1/100 \times f_{\text{WDC}}$	$f_{\text{WDC}}$	1		13	kHz
Minimum pulse duration for a securely WDI input pulse detection		$t_{\text{P,WDI}}$	182			$\mu\text{s}$
Frequency range for a correct WDI signal		$f_{\text{WDI}}$	64.7		112.5	Hz



## Electrical Characteristics (Continued)

$V_S = 5\text{ V}$ ,  $T_{amb} = -40\text{ to }+125^\circ\text{C}$ , reference pin is GND,  $f_{intern} = 100\text{ kHz} + 50\% - 45\%$ ,  $f_{WDC} = 10\text{ kHz} \pm 10\%$ ,  $f_{WDI} = 100\text{ Hz}$

Parameters	Test Conditions	Symbol	Min.	Typ.	Max.	Unit
Number of incorrect WDI trigger counts for locking the outputs		$n_{lock}$		3		
Number of correct WDI trigger counts for releasing the outputs		$n_{release}$		3		
Detection time for a stucked WDI signal	$V_{WDI} = \text{const.}$	$t_{WDIerror}$	24.5		25.5	ms
<b>Watchdog Timing Relative to <math>f_{WDC}</math></b>						
Minimum pulse duration for a securely WDI input pulse detection				2		Cycles
Frequency range for a correct WDI signal			80		169	Cycles
Hysteresis range at the WDI ok margins				1		Cycle
Detection time for a dropped out WDI signal	$V_{WDI} = \text{const.}$		250		251	Cycles

## Protection against Transient Voltages According to ISO TR 7637-3 Level 4 (Except Pulse 5)

Pulse	Voltage	Source Resistance <sup>(1)</sup>	Rise Time	Duration	Amount
1	-110 V	10	100 V/s	2 ms	15.000
2	+110 V	10	100 V/s	0.05 ms	15.000
3a	-160 V	50	30 V/ns	0.1 s	1 h
3b	+150 V	50	20 V/ns	0.1 s	1 h
5	40 V	2	10 V/ms	250 ms	20

Note: 1. Relay driver: relay coil with  $R_{min} = 70\ \Omega$  to be added



## Timing Diagrams

Figure 6. Watchdog in Too-fast Condition

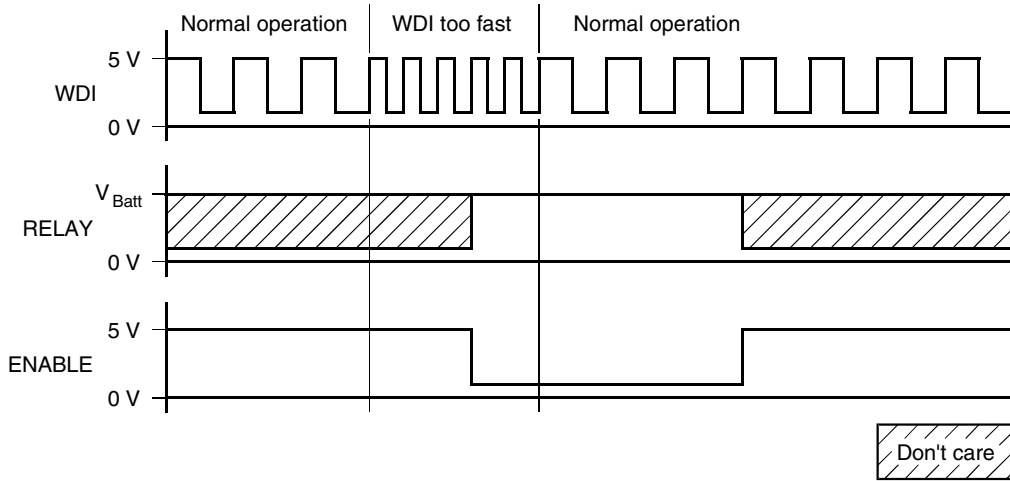
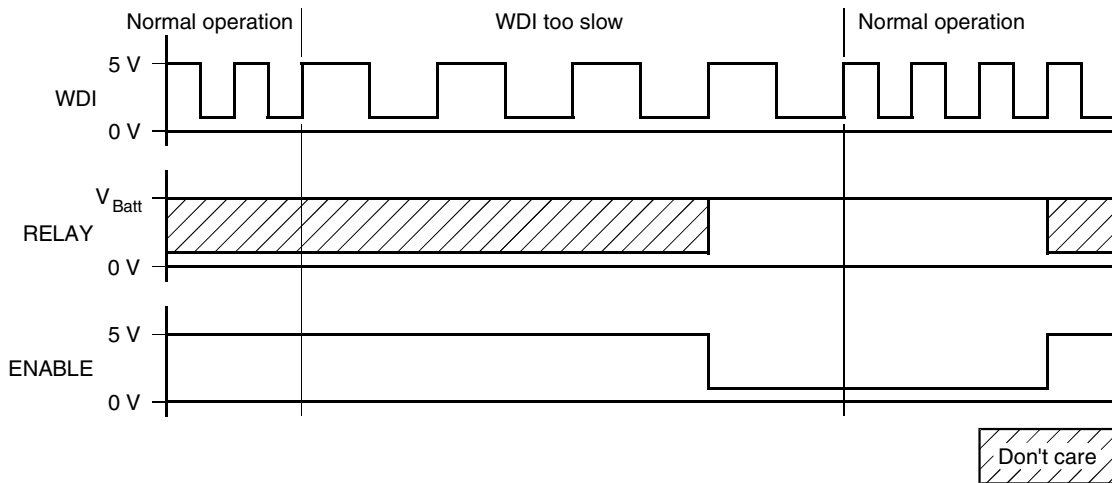
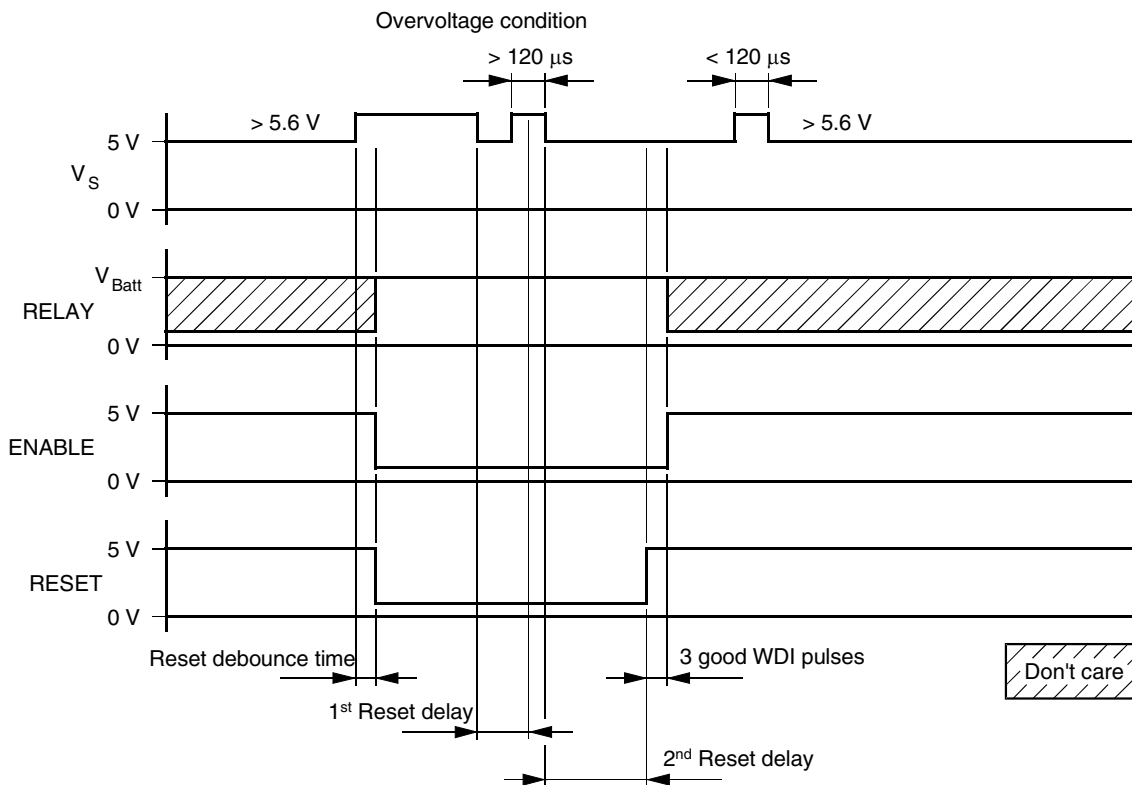

Figure 7. Watchdog in Too-slow Condition



**Figure 8. Overvoltage Condition**



**Figure 9. Undervoltage Condition**

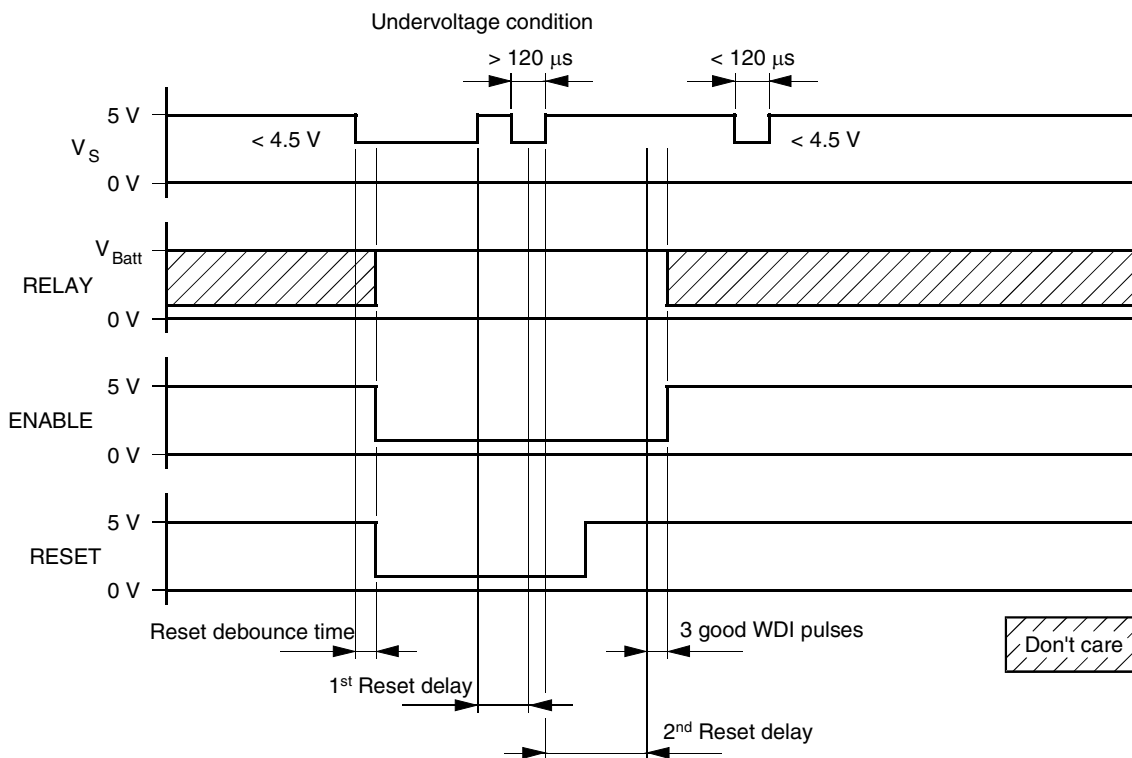

**Figure 10.** Application Circuit

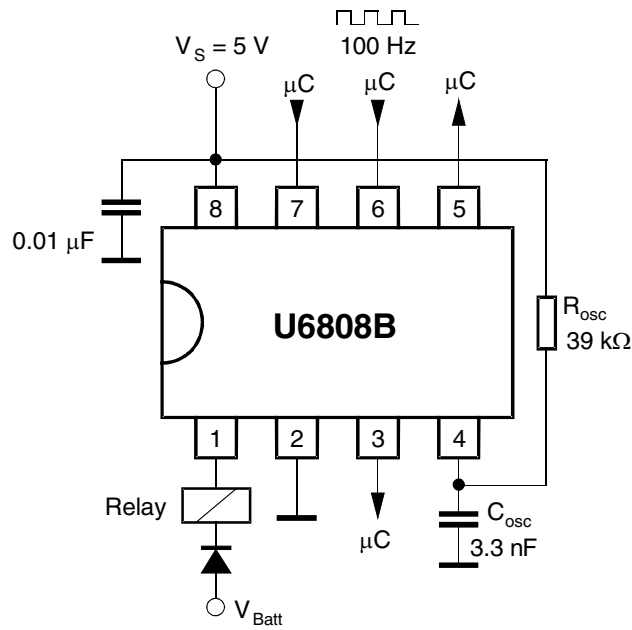

## Ordering Information

Extended Type Number	Package	Remarks
U6808B	SO8	—

## Package Information

Package SO8  
Dimensions in mm

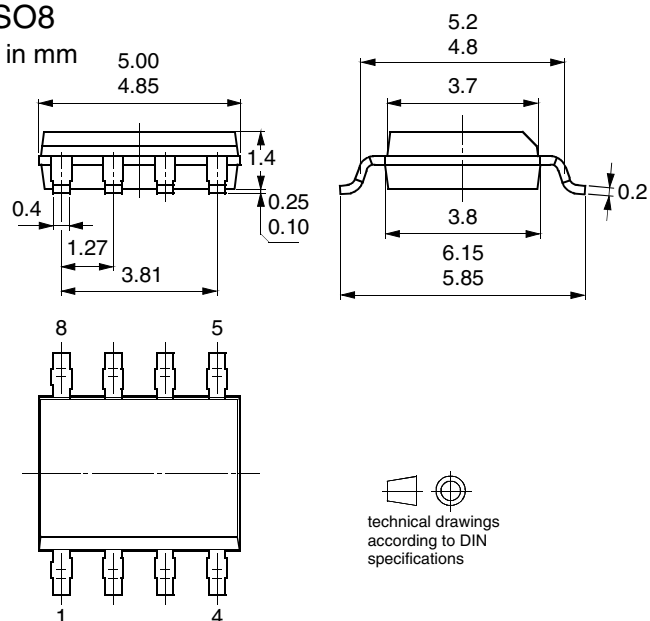



## Atmel Headquarters

**Corporate Headquarters**  
2325 Orchard Parkway  
San Jose, CA 95131  
TEL 1(408) 441-0311  
FAX 1(408) 487-2600

### *Europe*

Atmel Sarl  
Route des Arsenaux 41  
Case Postale 80  
CH-1705 Fribourg  
Switzerland  
TEL (41) 26-426-5555  
FAX (41) 26-426-5500

### *Asia*

Room 1219  
Chinachem Golden Plaza  
77 Mody Road Tsimhatsui  
East Kowloon  
Hong Kong  
TEL (852) 2721-9778  
FAX (852) 2722-1369

### *Japan*

9F, Tonetsu Shinkawa Bldg.  
1-24-8 Shinkawa  
Chuo-ku, Tokyo 104-0033  
Japan  
TEL (81) 3-3523-3551  
FAX (81) 3-3523-7581

## Atmel Operations

**Memory**  
2325 Orchard Parkway  
San Jose, CA 95131  
TEL 1(408) 441-0311  
FAX 1(408) 436-4314

### *Microcontrollers*

2325 Orchard Parkway  
San Jose, CA 95131  
TEL 1(408) 441-0311  
FAX 1(408) 436-4314

La Chantrerie  
BP 70602  
44306 Nantes Cedex 3, France  
TEL (33) 2-40-18-18-18  
FAX (33) 2-40-18-19-60

### *ASIC/ASSP/Smart Cards*

Zone Industrielle  
13106 Rousset Cedex, France  
TEL (33) 4-42-53-60-00  
FAX (33) 4-42-53-60-01

1150 East Cheyenne Mtn. Blvd.  
Colorado Springs, CO 80906  
TEL 1(719) 576-3300  
FAX 1(719) 540-1759

Scottish Enterprise Technology Park  
Maxwell Building  
East Kilbride G75 0QR, Scotland  
TEL (44) 1355-803-000  
FAX (44) 1355-242-743

### *RF/Automotive*

Theresienstrasse 2  
Postfach 3535  
74025 Heilbronn, Germany  
TEL (49) 71-31-67-0  
FAX (49) 71-31-67-2340

1150 East Cheyenne Mtn. Blvd.  
Colorado Springs, CO 80906  
TEL 1(719) 576-3300  
FAX 1(719) 540-1759

### *Biometrics/Imaging/Hi-Rel MPU/ High Speed Converters/RF Datacom*

Avenue de Rochepleine  
BP 123  
38521 Saint-Egreve Cedex, France  
TEL (33) 4-76-58-30-00  
FAX (33) 4-76-58-34-80

---

### *e-mail*

literature@atmel.com

### *Web Site*

<http://www.atmel.com>

## © Atmel Corporation 2003.

Atmel Corporation makes no warranty for the use of its products, other than those expressly contained in the Company's standard warranty which is detailed in Atmel's Terms and Conditions located on the Company's web site. The Company assumes no responsibility for any errors which may appear in this document, reserves the right to change devices or specifications detailed herein at any time without notice, and does not make any commitment to update the information contained herein. No licenses to patents or other intellectual property of Atmel are granted by the Company in connection with the sale of Atmel products, expressly or by implication. Atmel's products are not authorized for use as critical components in life support devices or systems.

Atmel® is the registered trademark of Atmel.

Other terms and product names may be the trademarks of others.



Printed on recycled paper.