



11-BAND EVR FOR GRAPHIC EQUALIZER

GENERAL DESCRIPTION

The NJU7306 is a electrical variable resistor (EVR) incorporated 11-band each for left and right channels, especially apply to the stereo type graphic equalizer.

It consists of input controller, channel/band/level selector, 22 latches and resistor network blocks of 11 bands each for left and right channels.

The boost and cut value for each band of each channel can be set independently to each other by the channel/band/level selector controlled by external controller.

The maximum boost and cut range is $\pm 12\text{dB}$ and the boost and cut value is adjusted by $\pm 2\text{dB}$ step.

PACKAGE OUTLINE

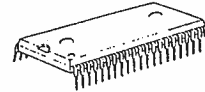

NJU7306L

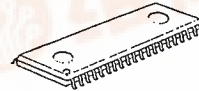

NJU7306G

FEATURES

- 11 Bands Each for Left and Right Channels
- Stereo Application Graphic Equalizer
- Each Channel Independent Operation
- Maximum Boost and Cut --- $\pm 12\text{dB}$
- Boost and Cut Step --- $\pm 2\text{dB}$
- 10bit Serial Data for the Equalizing
- Flat Level Setting Function
- Operating Voltage --- $15\text{V}\sim 30\text{V}$
- Package Outline --- SDIP 42/SOP 40
- C-MOS Technology

BLOCK DIAGRAM

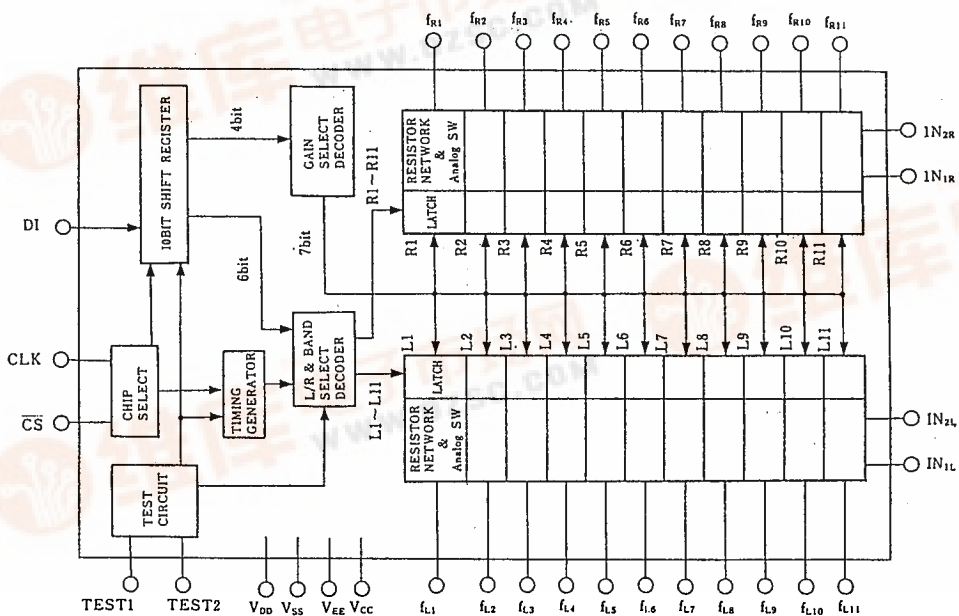

NJU7306

PIN CONFIGURATION

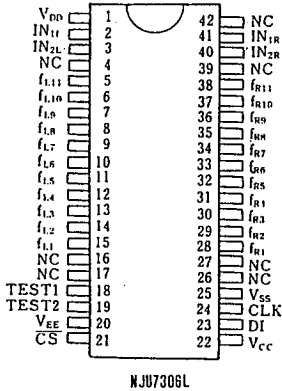

NJU7306L

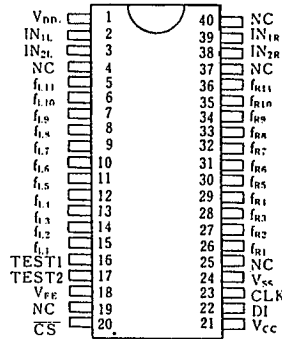

NJU7306G

TERMINAL DESCRIPTION

NO.		SYMBOL	FUNCTION
NJU7306L	NJU7306G		
1	1	V_{DD}	Power source for Audio signal +15V
25	24	V_{SS}	GND 0V
20	18	V_{EE}	Power source for Audio signal -15V
22	21	V_{CC}	Power source for Logic +5.0V
2, 41	2, 39	IN_{1L}, IN_{1R}	Audio signal input terminal. Connect to Op-amp inverting terminal
3, 40	3, 38	IN_{2L}, IN_{2R}	Audio signal input terminal. Connect to Op-amp non-inverting terminal
5 to 15 28 to 38	5 to 15 26 to 36	f_{L1} to f_{L11} f_{R1} to f_{R11}	Band pass filter connecting terminal. (22 terminals for left/right)
18	16	TEST1	Maker testing terminals.
19	17	TEST2	Normally (except the test) OPEN
21	20	\overline{CS}	Chip-select input.
23	22	DI	Serial data input.
24	23	CLK	Clock signal input.
4, 16, 17 26, 27, 39 42	4, 19, 25 37, 40	NC	Non connection

■ FUNCTIONAL DESCRIPTION

(1) Data set and code format

The setting of each band is performed by two signals of data and clock as shown in Fig.1.

The 10 bits serial data including the information of channel selection (left/right), band selection and its gain are input from DI terminal.

The clock signal input from the CLK terminal shifts the serial data input from DI terminal into the shift register.

The data input from DI terminal is performed during the CS terminal is "L" level. Then the CS terminal change from "L" to "H" level, the data in the shift register is latched to the latch.

All "H" of 10 bits code are special code to set 0dB for all bands at once. This function is useful for Power On initialization or flat level setting.

< Data and Shift Clock >

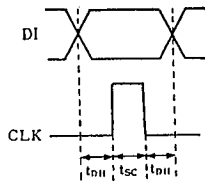

The shift clock should be risen after 1μs from the data changing.
 $t_{sc} = 1\mu s(\text{MIN})$
 $t_{DH} = 1\mu s(\text{MIN})$

< Time Chart >

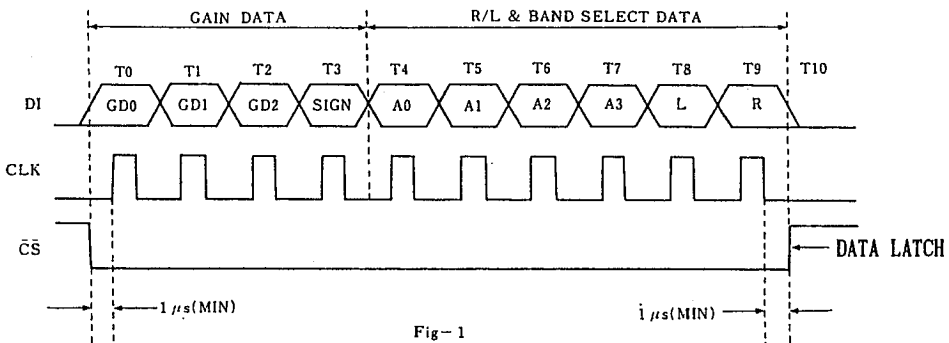

Fig-1

The CS terminal should be "L" level during the data input. The setting data is latched at the edge of CS signal rising. If the error data is latched, the correct data must be set again from the top.

Note: The clock line should be shielded from the noise.

NJU7306

< Data Format >

The data is input by the LSB first format as shown bellow. And the gain data GD2 to GD0, left/right and band selection data are also shown in bellow.

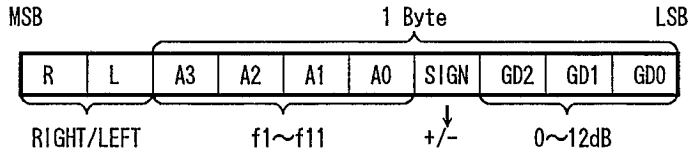

GAIN DATA CODE

GAIN	SIGN	GD2	GD1	GD0
12	0	1	1	0
10	0	1	0	1
8	0	1	0	0
6	0	0	1	1
4	0	0	1	0
2	0	0	0	1
0dB	0	0	0	0
-2	1	0	0	1
-4	1	0	1	0
-6	1	0	1	1
-8	1	1	0	0
-10	1	1	0	1
-12	1	1	1	0

BAND SELECT DATA CODE

BAND	A3	A2	A1	A0
f1	0	0	0	1
f2	0	0	1	0
f3	0	0	1	1
f4	0	1	0	0
f5	0	1	0	1
f6	0	1	1	0
f7	0	1	1	1
f8	1	0	0	0
f9	1	0	0	1
f10	1	0	1	0
f11	1	0	1	1

R/L SELECT DATA CODE

R/L	R	L
RIGHT	1	0
LEFT	0	1
RIGHT & LEFT	1	1

(2) Power on initialization

The NJU7306 is not incorporated the Power On Initialization Circuits, so that internal circuits are not defined when the power is turned on. Therefore, the flat setting operation are required as 10 bits of "H" data with 10 clock pulse input during the CS terminal "L" state, then after change the CS terminal level from "L" to "H".

The internal circuits of NJU7306 are initialized by the above operation, then the following input will be accepted.

■ ABSOLUTE MAXIMUM RATINGS

(Ta=25°C)

PARAMETER	SYMBOL	RATINGS	UNIT
Supply Voltage	$V_{DD}-V_{EE}$	34	V
	V_{CC}	$V_{SS} \sim V_{SS} + 7 (V_{DD} \geq V_{CC})$	
Input Voltage	V_{IN}	$V_{SS} - 0.3 \sim V_{CC} + 0.3$ (DI, CLK, \overline{CS})	V
		$V_{EE} - 0.3 \sim V_{DD} + 0.3$ ($I_{N1L} \sim I_{N2L}, I_{N1R} \sim I_{N2R}$)	
Power Dissipation	PD	250 (SDIP, SOP)	mW
Operating Temperature	T_{OPR}	-30 ~ +80	°C
Storage Temperature	T_{STG}	-40 ~ +125	°C

■ ELECTRICAL CHARACTERISTICS

($V_{SS}=0V, V_{DD} \geq V_{CC} > V_{SS} \geq V_{EE}, Ta=25^\circ C$)

PARAMETER	SYMBOL	CONDITIONS	MIN	TYP	MAX	UNIT
Operating Voltage	$V_{DD}-V_{EE}$	$V_{EE} \geq -15V$	15	20	30	V
	V_{CC}		4.5	5.0	5.5	
Operating Current	I_{DD}	$V_{DD}-V_{EE}=30V$			1	mA
	I_{CC}	$V_{CC}=5V$			0.5	
Input Voltage	V_{IH}	CLK, DI, \overline{CS}	0.8 V_{CC}		V_{CC}	V
	V_{IL}	Terminals	0		0.2 V_{CC}	
Input Pulse Width	t_{PW}	CLK	1			μS
Setup Time	t_{SU}	DI	1			μS
Holding Time	t_{HLD}	DI	1			μS
Operating Frequency	f_{OPR}	CLK			330	kHz
Total Harmonics Distortion	THD1	Flat Status, f=20kHz		0.005	0.01	%
	THD2	Flat Status, f= 1kHz		0.0015	0.003	
	THD3	Boost Status, f=20kHz		0.05	0.10	
	THD4	Boost Status, f= 1kHz (Circuit 1)		0.015	0.03	
Crosstalk	CT	f= 1kHz (Circuit 2)		60		dB
Setting Error	ΔB	$V_{DD}-V_{EE}=30V$ (Circuit 1)	-1		1	dB
Analog SW Off Leakage Current	I_{off}	$f_{L1} \sim f_{L11}$ $f_{R1} \sim f_{R11}$			100	μA

Note) The setting error of gain is specified by measuring of Circuit 1 based on internal current flown on Circuit 3.

Actual setting error of gain is affected by external circuit characteristics. Therefore, experimental operation is recommended when designing.

NJU7306

MEASUREMENT CIRCUITS

Circuit 1

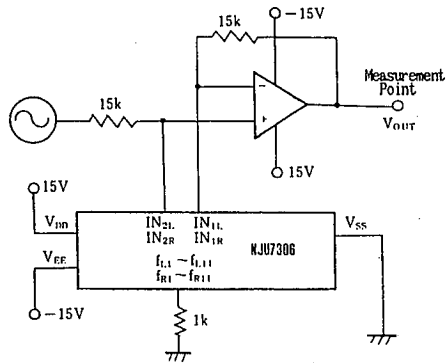

Circuit 2

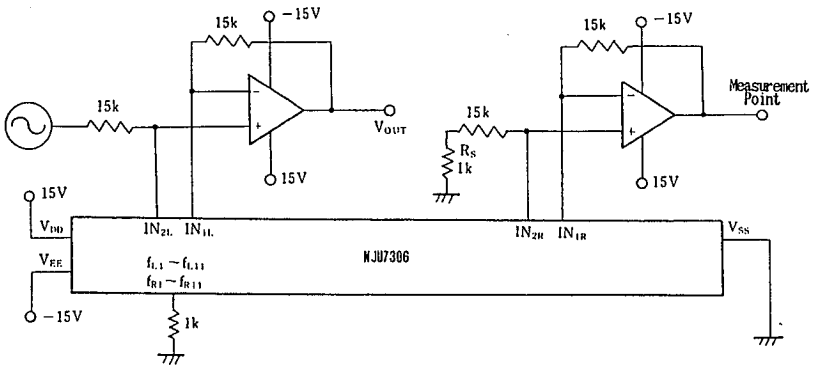

Circuit 3

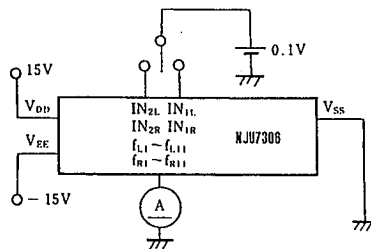

APPLICATION CIRCUIT 1

< Single power supply operation >

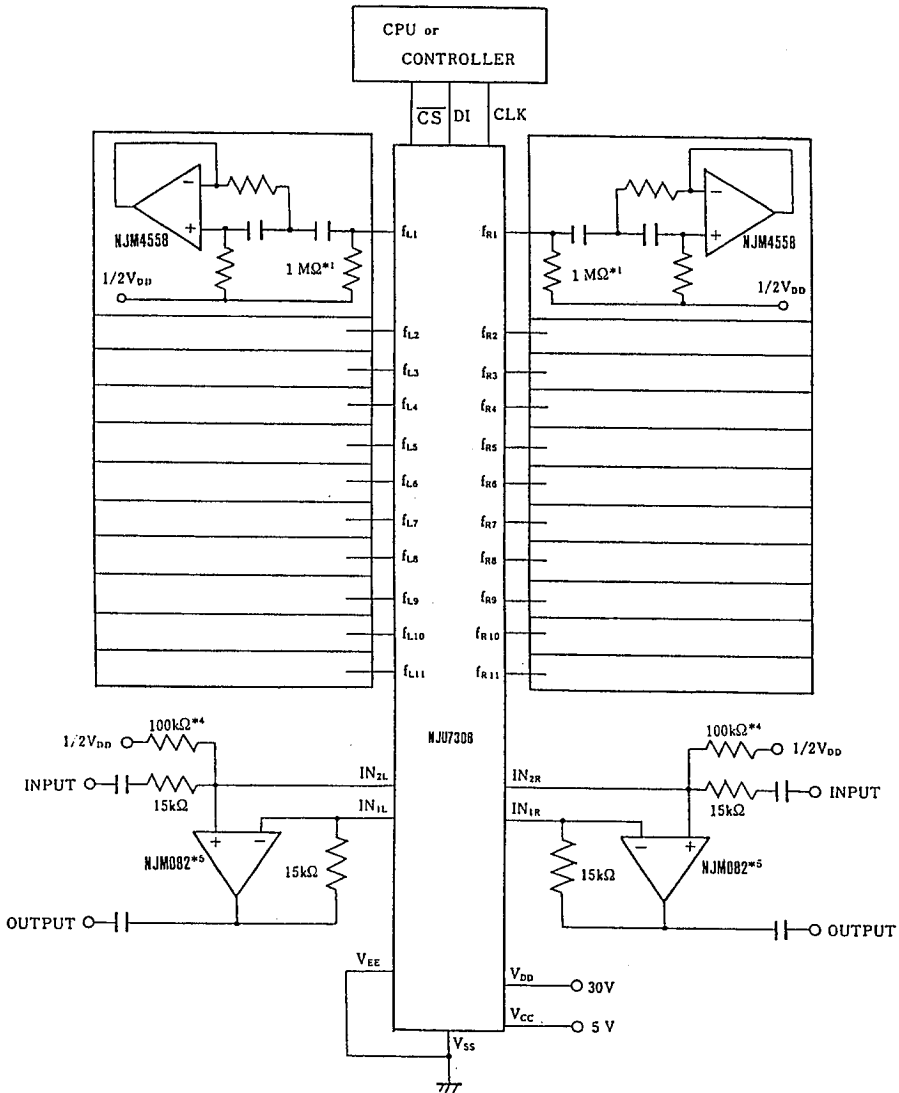

- *1) In order to reduce the pop-noise, connecting $f_{L1} \sim f_{L11}$, $f_{R1} \sim f_{R11}$ to $1/2 V_{DD}$ by $1M\Omega$ resistance is recommended.
- *2) The best conditions for 2dB/step are as follows:
 $V_{DD} = 30V$
 OP-amp feedback resistance: $15k\Omega$.
 Equivalent LC resonant impedance: $1k\Omega$
- *3) TEST1 and TEST2 terminals are normally OPEN.
- *4) In order to keep off noise input, connecting to $1/2 V_{DD}$ by $100k\Omega$ resistance is recommended.
- *5) J-FET input OP-AMP is recommended.

NJU7306

APPLICATION CIRCUIT 2

< Dual power supply operation >

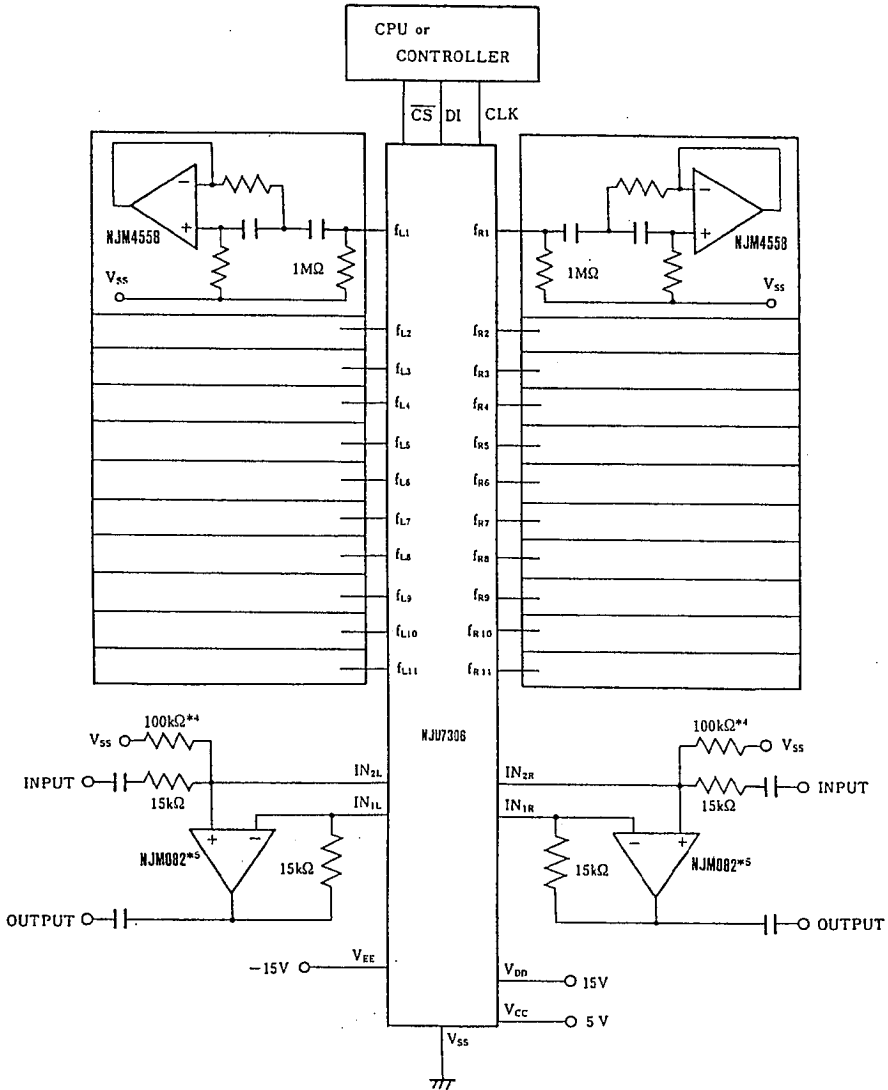

- *1) In order to reduce the pop-noise, connecting $f_{L1} \sim f_{L11}$, $f_{R1} \sim f_{R11}$ to V_{SS} by 1MΩ resistance is recommended.
- *2) The best conditions for 2dB/step are as follows:
 $V_{DD} = 15V$, $V_{EE} = -15V$
 OP-amp feedback resistance: 15kΩ.
 Equivalent LC resonant impedance: 1kΩ
- *3) TEST1 and TEST2 terminals are normally used as OPEN.
- *4) In order to keep off noise input, connecting to $1/2 V_{DD}$ by 100kΩ resistance is recommended.
- *5) J-FET input OP-AMP is recommended.

NJU7306

MEMO

[CAUTION]

The specifications on this databook are only given for information, without any guarantee as regards either mistakes or omissions. The application circuits in this databook are described only to show representative usages of the product and not intended for the guarantee or permission of any right including the industrial rights.